

Quick 50

Pro/Sport Helicopter



ASSEMBLY & MAINTENANCE MANUAL

2nd Version

TABLE OF CONTENTS

INTRODUCTION	3
CUSTOMER SERVICE	4
FEATURES	5
FRE-ASSEMBLY INFORMATION	6
REQUIRED TOOLS	7
HARDWARE & OPTIONAL ACCESSORIES	8
OTHER HARDWARE & OPTIONAL ACCESSORIES	9
OTHER REQUIREMENTS	12
PART LIST	13
SECTION 1: UPPER FRAMES	14
SECTION 2: LOWER FRAMES	28
SECTION 3: LANDING GEAR ASSEMBLY	40
SECTION 4: DRIVING SYSTEM	42
SECTION 5: TAIL ASSEMBLY	44
SECTION 6: CONTROL SYSTEMS	50
SECTION 7: ROTOR HEAD	53
SECTION 8: LINKAGE RODS AND SETTINGS	56
FRE-LIGHT CHECKS	72
WARNINGS	73
ADJUSTMENTS	74
HOW TO HOVER	75
HOW TO FLY FORWARD	77
AFTER FLIGHT CHECKS	78
WHAT IF THE HELICOPTER CRASHED	78
SPECIFICATION	79

INTRODUCTION

Congratulation and thank you for the purchase of great product! It is our sole desire for you to enjoy the quality workmanship and performance of any of our Nitro powered helicopters. We believe we have the latest designs and technology incorporated into our model helicopters. Our CNC parts are produced using the best high density materials & anodized using material hardening finishes with the tightest of tolerances. Our new helicopters feature the latest advances in R/C helicopter design. The simple and mechanically superior EMS design (also known as CCPM) ensures a helicopter that will be more responsive and more stable than any other R/C helicopter you have ever flown. Three servos are attached directly to the Swashplate to ensure precise control. This kit features all metal construction, and a carbon or composite frames are standard. Along with great products, our staffs are RC guys that fly and have hands on experience with total manufacturing & testing of our helicopters. In addition, we stand behind all our products 100% with satisfaction guaranteed. Our kits will be shipped 100% complete and we can assure you that once you fly your helicopter you will love it.

The **QUICK 50**

We believe you hold in your hands one of the best helicopters manufactured in the world today. The **Quick 50** is one of the famous versions of our Big Nitro Quick line. It is a bigger, stronger frames, yet powerful machine. This baby delivers amazing power smoothly throughout the entire range of its nitro motor. It functions so responsive and stable. The **Quick 50 Pro version** features a fully machined head, metal grips, dual bearing tail rotor, carbon fiber frames, carbon rudder push rod, and carbon fiber boom supports. The **Big Quick 50 Sport version** features a G10 fiberglass frame, machined metal head, molded plastic grips, carbon boom supports, carbon rudder push rod, and dual bearing tail rotor. Our helicopters are carefully designed and tested, and manufactured of the highest quality materials available.

In a short time, you can be flying.

We ask that you please read the entire manual before starting the construction of the **Quick 50**, and if you have any questions our technical support staff can be reached at

(610) 282-4811 M-F 9-6, S 9-4 Eastern time,
or by email at chuck@quickworldwide.com.

For the latest information and updates, please visit our website at

www.quickworldwide.com

CUSTOMER SERVICE

<p>Quickworldwide 201 South 3rd. St. & 309 N. Coopersburg, PA 18036</p> <p>Phone: (610)-282-4811</p> <p>Fax: (610)-282-4816</p>	<p><u>Websites:</u> http://www.hhiheli.com http://www.quickheli.com http://www.giantscaleplanes.com</p> <p><u>E-mail:</u> hhi@fast.net</p>
<p><u>Office Hours:</u></p> <p>Mon – Fri: 8:30 – 6:00 Sat: 8:30 – 1:30 (Eastern Daylight Time)</p>	
<p>Technical Support Personnel:</p> <p>Chuck – chuck@quickworldwide.com Jon – jon@quickworldwide.com</p>	

FEATURES

- 1. Frame Construction:** Quick 50 frames are made of the highest Quality Black G-10 Frames or Carbon Fiber. These frames are not only rigid but will provide excellent vibration absorption.
- 2. One-Way Hex Start Shaft System:** The one-way bearing allows the engine to continue to run after the starter motor has been stopped.
- 3. Constant Tail Rotor Drive System:** The constant tail system will provide full tail authority during engine off maneuvers.
- 4. Belt driven Tail:** Belt Driven tail is not only a reliable way to drive a tail, but is also very smooth and low maintenance.
- 5. High Quality Ball Bearings:** Quick 50 offers ball bearings on all moving parts.
- 6. EMS Collective System:** The EMS Collective design allows ease of setup with fewer moving parts. EMS constitutes overall design simplicity and represents the future of helicopter technology.
- 7. Heavy-Duty Clutch System:** Based on the same design as our famous heavy-duty clutch upgrade that fits most popular machines, this clutch will give many years of problem free operation.
- 8. Control Linkages:** The control linkages that are provided with the Quick Learner Kit are high quality 2.3mm stainless steel rods and the rod ends are made of a high quality Delrin.
- 9. Single Blade Axle Design:** The single blade axle design is simple very responsive system, with very consistent flight characteristics.
- 10. Advanced Airfoil Fly-bar Paddles:** These paddles will provide the best both kind of flight characteristics for both 3D & Sport flying. Not only do they provide smooth forward flight, they also provide quick response upon demand.
- 11. Rearward facing Engine Design:** This design provides quick access to the glow plug and is advantageous for easy engine removal.

PRE-ASSEMBLY INFORMATION

Warning

The radio-controlled model helicopter contained in this kit is not a toy. Rather, it is a sophisticated piece of equipment. This product is not recommended for use by children without adult supervision. Radio controlled models such as this are capable of causing both property damage and/or bodily harm to both the operator/assembler and spectators if not properly assembled and operated. Hobbies & Helis assumes no liability for damage that could occur from the mis-assembly and/or use/misuse of this product.

Academy of Model Aeronautics

We strongly encourage all prospective and current R/C aircraft pilots to join the Academy of Model Aeronautics. The AMA is a non-profit organization that provides services to model aircraft pilots. As an AMA member, you will receive a monthly magazine entitled Model Aviation, as well as a liability insurance plan to cover against possible accident or injury. All AMA charter aircraft clubs require individuals to hold a current AMA sporting license prior to the operation of their model. For further information, please contact AMA at:

Academy of Model Aeronautics

5161 East Memorial Drive

Muncie, IN 47302-9252

USA









Phone: (317) 287-1256

www.modelaircraft.org

Before you begin

Quick Helicopter kits are packaged with care and attention to detail. We recommend when you are ready to begin building this model that you examine the kit carefully, inspect the contents of each package, and read and understand these instructions thoroughly before starting assembly. It is suggested that you purchase a parts box for the small fasteners and hardware, or use small bowls or other containers.

REQUIRED TOOLS

 <p>Phillips Screw Driver</p>	 <p>Ball End Drivers HHI7050</p>	 <p>Bubble Blade Balancer HHI7010 High Point Balancer DUB499</p>
 <p>Piston Head Lock HHI7020</p>	 <p>HHI7320 – 6pc Nut & Allen Driver Set</p>	 <p>Pitch Gauge HHI7001</p>
 <p>Composite Paddle Gauges HHI7000</p>		 <p>Universal FlybarLock HHI7040</p>
 <p>Ruler</p>	 <p>Hobby Knife</p>	 <p>Needle Nose Pliers</p>
		 <p>Scissors</p>

HARDWARE & OPTIONAL ACCESSORIES

GLUES AND THREAD LOCK COMPOUNDS

		
Ca Glue. ...GBG1	JB Weld...JBW8265S	Loctite.PT40

RADIO MOUNTING ACCESSORIES

	
Single Sided Foam Tape... HHI2008	Receiver Hold Down Straps HHI55** \$4.99 2 Per Bag & Colors: Red, White, Purple, Black
	
Receiver Strong Box... HHI2200	Spiral Wrap HHI2809 & HHI2810
	
Wire Ties...HHIWT01	

ENGINES, GLOW PLUGS, AND EXHAUST SYSTEM

ENGINES: we recommend OS50SX but others may work



GLOW PLUGS: OS # 8...OSMG2691



One-Piece Muffler



Two-Piece Muffler



FUEL SYSTEM



Fuel Filter... QUI9002



Tube Ends.... QUI9001



Mini Cock Straight... TET4321



Fuel Tubing.... PRA7092



Triangle Joint. TET4301

OTHER HARDWARE & OPTIONAL ACCESSORIES



3MM FLYBAR STIFFENERS
HHI 402



60 SIZE SKID STOPS
HHI 200 AVAILABLE IN COLORS



SERVO
ARM SET



LANDING GEAR DAMPENERS HHI2004

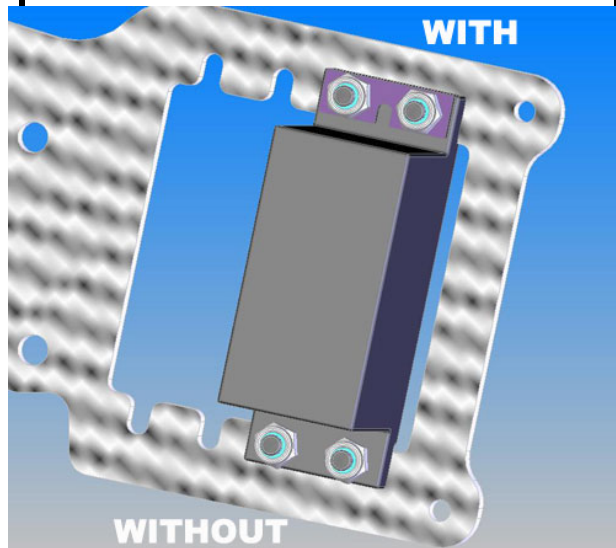

SERVO FIXING PLATES

- Transmits force of fastener to plastic instead of rubber
- **HHI 1205 SERVO MOUNT KIT**
- Includes hardware and fixing plates to mount 5 servos

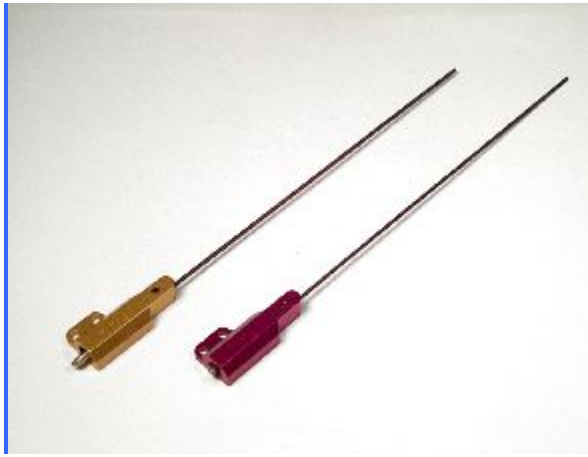

**BASE LOAD ANTENNA
HHI 53****

AVAILABLE IN BLUE, GOLD,
PURPLE
AND IN 40, 50, AND 72 MHz

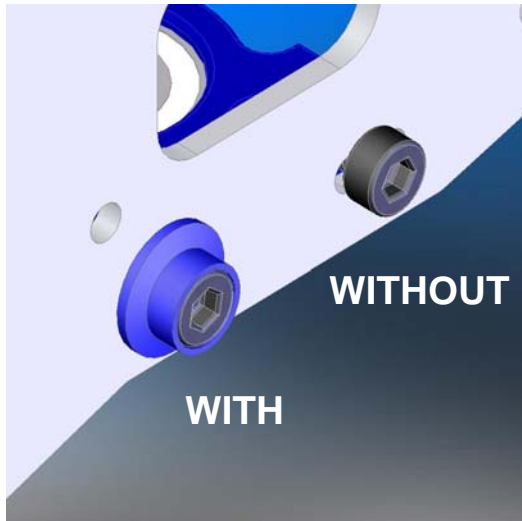

FINISHING CAPS

- Adds color and style
- Distributes force across larger surface area

3mm

4mm

(20 pcs in a package) (8 pcs in a package)

BLACK	HHIM11100B	---
BLUE	HHIM11103	HHIM11108
GOLD	HHIM11101	HHIM11106
GREEN	HHIM11100G	---
PURPLE	HHIM11100	HHIM11105
RED	HHIM11100R	---
SILVER	HHIM11100	HHIM11107

OTHER REQUIREMENTS

Radios:

Any radio that supports EMS/CCPM Mixing will work fine. Hobbies & Helis & its distributors carry various lines of helicopter radios.

Note: Please consult the instruction for your Gyro for setting the overall travel and limits to ensure proper operation and travel of Tail Pitch Slider.

Servos:

Any sport servo will offer acceptable performance. However, because servos operate all critical functions of the helicopter, they can be the single most important component that contributes to proper function of the helicopter. Due to the nature of EMS collective, we suggest the use of digital servos to enhance and ensure matched servo timing without servo interaction.

Locktite Warning (CRITICAL):

This is a general warning about the use of Locktite and its importance. **Locktite must be used anywhere that a metal fastener** i.e. (M2, M3, M4 Cap Head Bolts, Set Screws etc.) **is threaded into a metal part** i.e. (Bearing Blocks, Cross-members, etc.). **Failure to use Locktite can result in loosening of critical operating components, loss of control of the model, and can lead to a crash.**

PART LIST

- In your kit, parts are bagged according to each major assembly and are labeled “Bag 1, Bag 2, etc.” You will note that the heading for each assembly indicates which bag correlates with each assembly.
- For a good installation, only open up the bag that you need for particular assembly.
- Please check the parts in that bag against the parts list shown for each assembly as well as each subassembly to make sure there are no missing parts.
- Small parts such as nuts and bolts can be put into containers or trays to prevent losing parts.
- Part No. with ***** means that part is not included in the kit.
- The colors of drawings in this manual may look different from the parts you have in the kit.

No.	Bag No.	Description	Quantity	Check
1	Bag 1	For Upper Frame Assembly	1	
2	Bag 2	For Lower Frame Assembly	1	
3	Bag 3	Landing Gear	1	
4	Bag 4	Driving System	1	
5	Bag 5	For Tail Assembly	1	
6	Bag 6	Control System	1	
7	Bag 7	Head Rotor	1	
8	Bag 8	Linkage	1	
9	Frame	Frame	1	
10	HB	Hardware Bag	1	
11	Loose in Box	Canopy	1	
		Carbon Push Rod	1	
		Tail Gear Belt	1	
		Tail Boom	1	
		Flybar	1	
		Decal Sheet	1	
		Instruction CD	1	

SECTION 1: UPPER FRAMES

Bag 1

- In your kit, parts are bagged according to each major assembly and are labeled “Bag 1, Bag 2, etc.” You will note that the heading for each assembly indicates which bag correlates with each assembly.
- For a good installation, only open up the bag that you need for particular assembly.
- Please check the parts in that bag against the parts list shown for each assembly as well as each subassembly to make sure there are no missing parts.
- Small parts such as nuts and bolts can be put into containers or trays to prevent losing parts.
- No. with ***** means that part is not included in the kit.
- Colors of the parts in the drawings may look differently from ones in the kit.

1-1 ELEVATOR SHAFT BEARINGS

No.	Bag#	Description	Qty
1	Frame	Upper Frame (from Frame Bag)	2
2	1	5X10X4Flanged Bearing	2

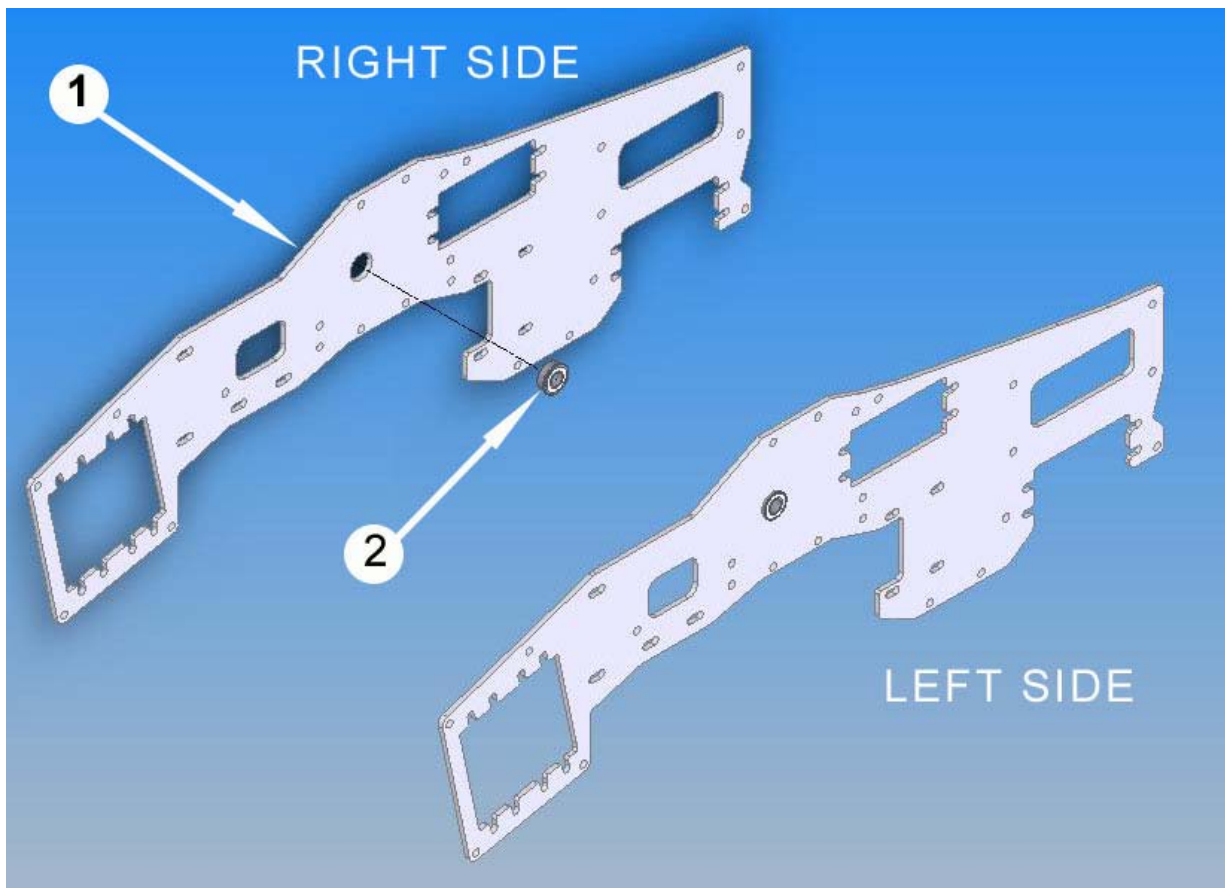

Note: The holes on the frames are designed for “push-fit” feature. Sometime you may have to sand them a little bit before pushing the bearings in. The bearing flange mates against the inside of the frame.

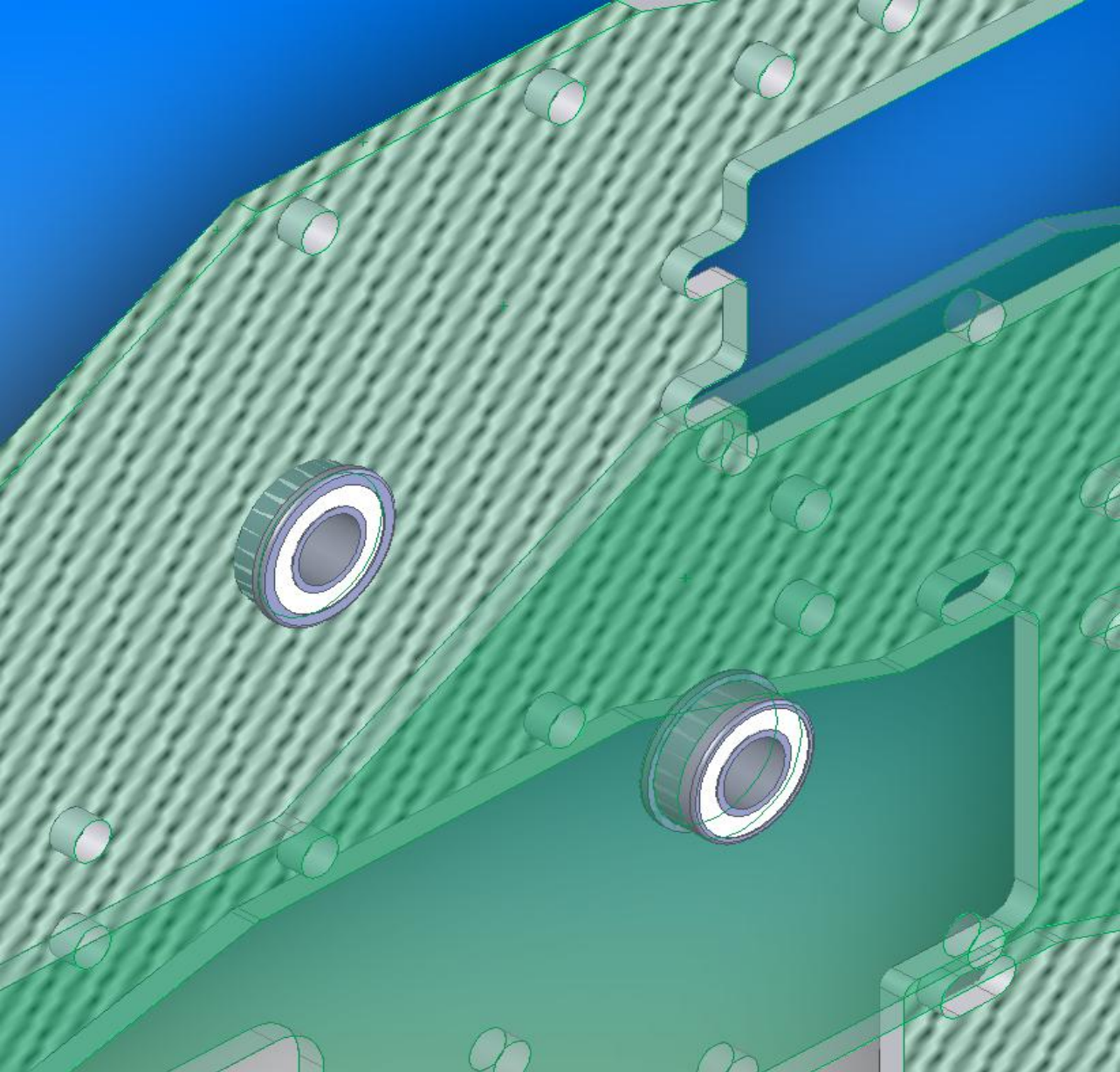

1-2 LEFTAILERON & RUDDER SERVO SUBASSEMBLY

No.	Bag#	Description	Qty
1	Step	L. Upper Frame Subassembly	1
2****		Servo	2
3	HB	M2.5x14 Cap Head Bolt	8
4	HB	M2.5 Locknut	8

**** Part No. with **** means that part is not included in the kit.

Note: If the servos come with anti-vibrating rubber, insert them on the servos first. We recommend using the servo fixing plates to protect and get the best performance from the servos. Please see “*Hardware & Optional Accessories*” for more details.

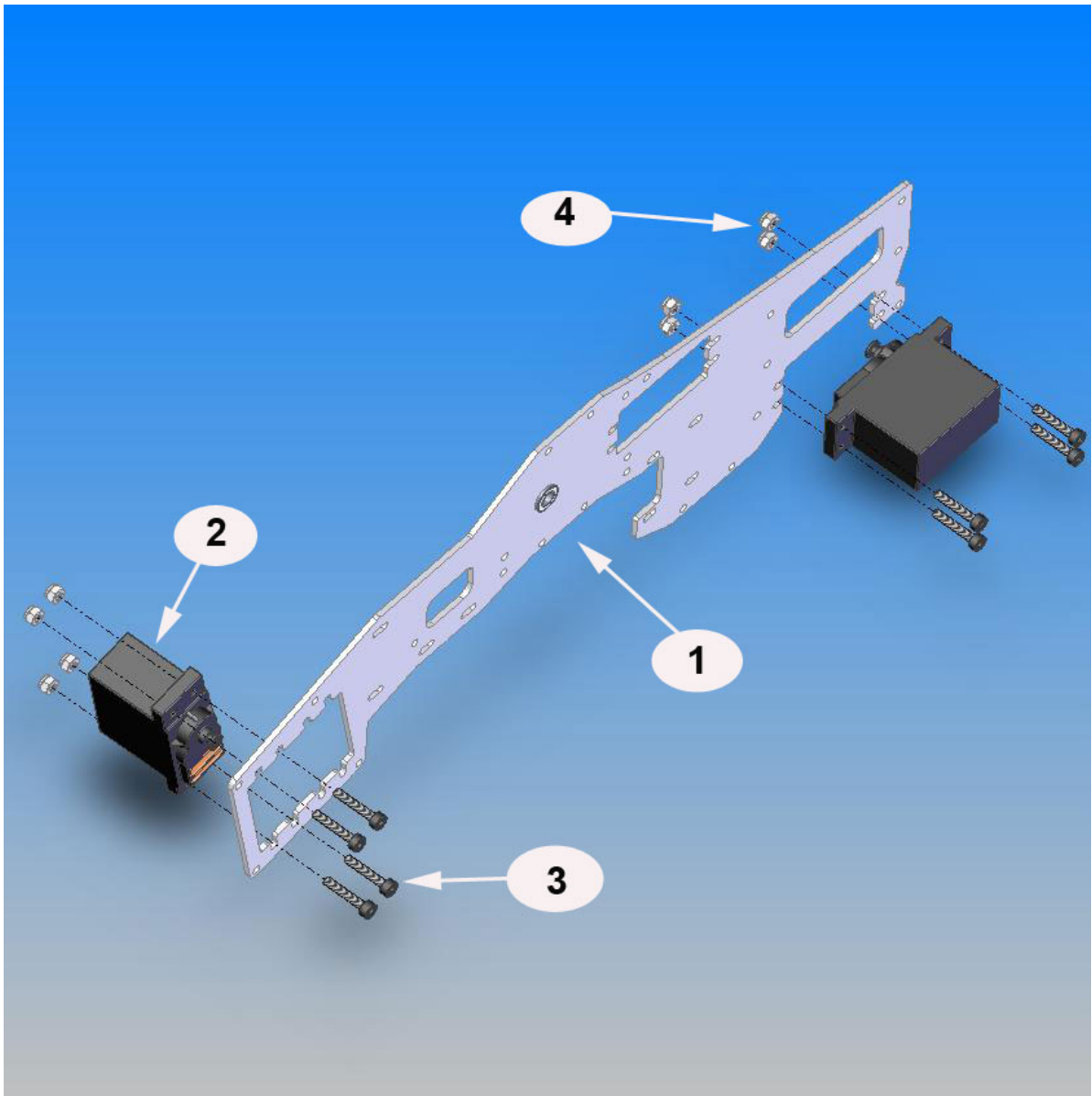

1-3 RIGHT AILERON & ELEVATOR SERVO SUBASSEMBLY

No.	Bag#	Description	Qty
1	Step 1-1	R. Upper Frame Subassembly	1
2		Servo	2
3	HB	M2.5x14 Cap Head Bolt	8
4	HB	M2.5 Locknut	8

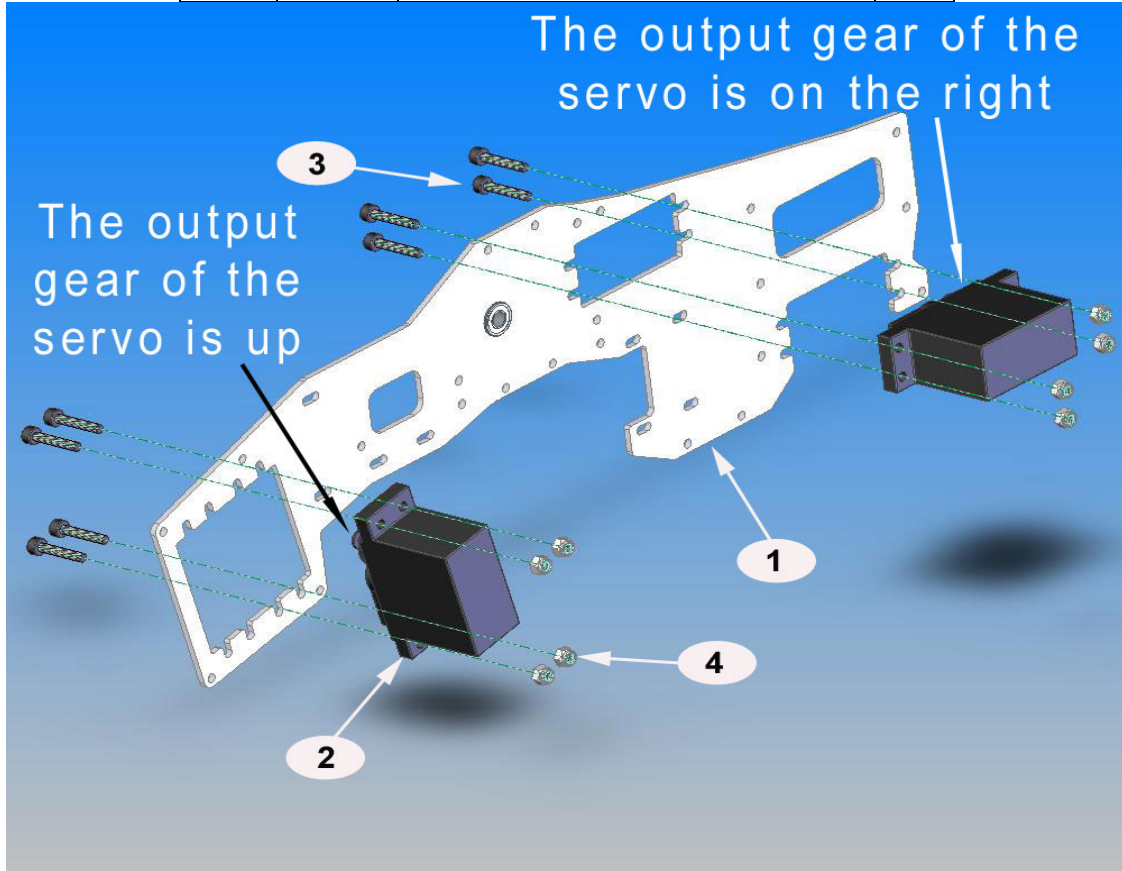

1-4 INNER ELEVATOR CONTROL ARM SUBASSEMBLY

No.	Bag #	Description	Qty
1	1	Inner Elevator Control Arm	1
2	1	Elevator Control Shaft	1
3	HB	M3x5 Set Screw	1
4	HB	M3x7 Pivot Ball Stud	1

Note: Remember to apply Locktite for Set Screw and Pivot Ball Stud (see *Locktite Warning* on page 11)

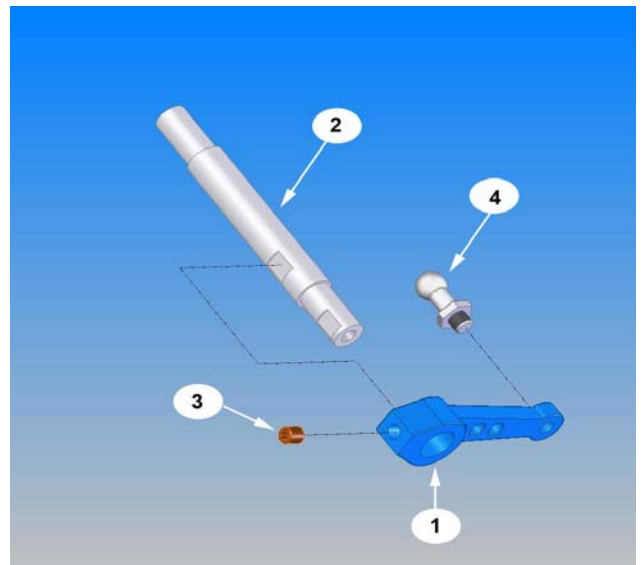

1-5 TAIL TRANSMISSION SUBASSEMBLY

No	Bag#	Description	Qty	
1	1	Counter Gear	1	-Install Counter Gear to Counter Gear Shaft using Counter Gear Lock Pin (No. 3) and M4 E-clip to secure it. Apply JP Weld glue around the pin. -Put Counter Gear Bearing Block (the lower) in with the Flange facing up -Install Counter Gear Bearing Block (the upper) with the Flange facing up -Install Pulley Gear Plate (No. 6) -Insert Pulley Gear Lock Pin (No. 7). Apply JP Weld glue around the pin -Install Pulley Gear and retain with M4 E-clip
2	1	Counter Gear Shaft	1	
3	1	Counter Gear Lock Pin	1	
4	1	M4 E-clip	2	
5	1	Counter Gear Bearing Block	2	
6	1	Pulley Gear Plate	1	
7	1	Pulley Gear Block Pin	1	
8	1	Pulley Gear	1	
9	*****	JP Weld glue	1	

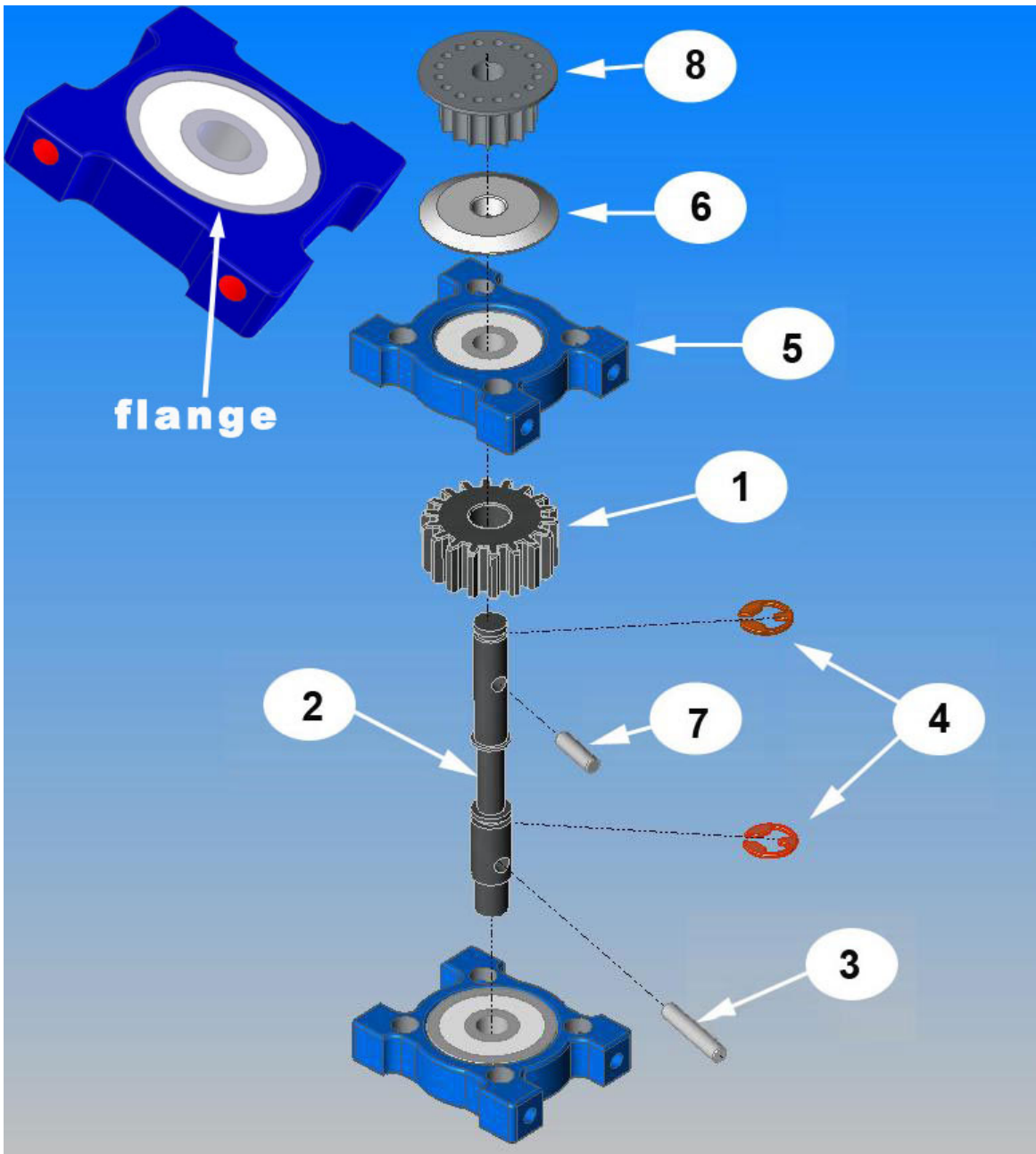

1-6 UPPER FRAME INSTALLATION

1-6-a ELEVATOR CONTROL ARM-RIGHT SIDE

No.	Bag#	Description	Qty
1	Step 1-3	R. A&E Arm Subassembly	1
2	Step 1-4	Inner El. Ctrl. Arm Subassembly	1
3	1	Outer Elevator Control Arm	1
4	HB	M3x5 Set Screw	1
5	HB	M3x4 Pivot Ball Stud	5
6	HB	M3x5x3 Spacer	1
7	1	Right Aileron Control Lever	1
8	HB	M3x12 Cap Head Bolt	1

Note: The Inner Elevator Control Arm (belongs to Inner Elevator Control Arm Sub assembly) should be next to the upper right frame.

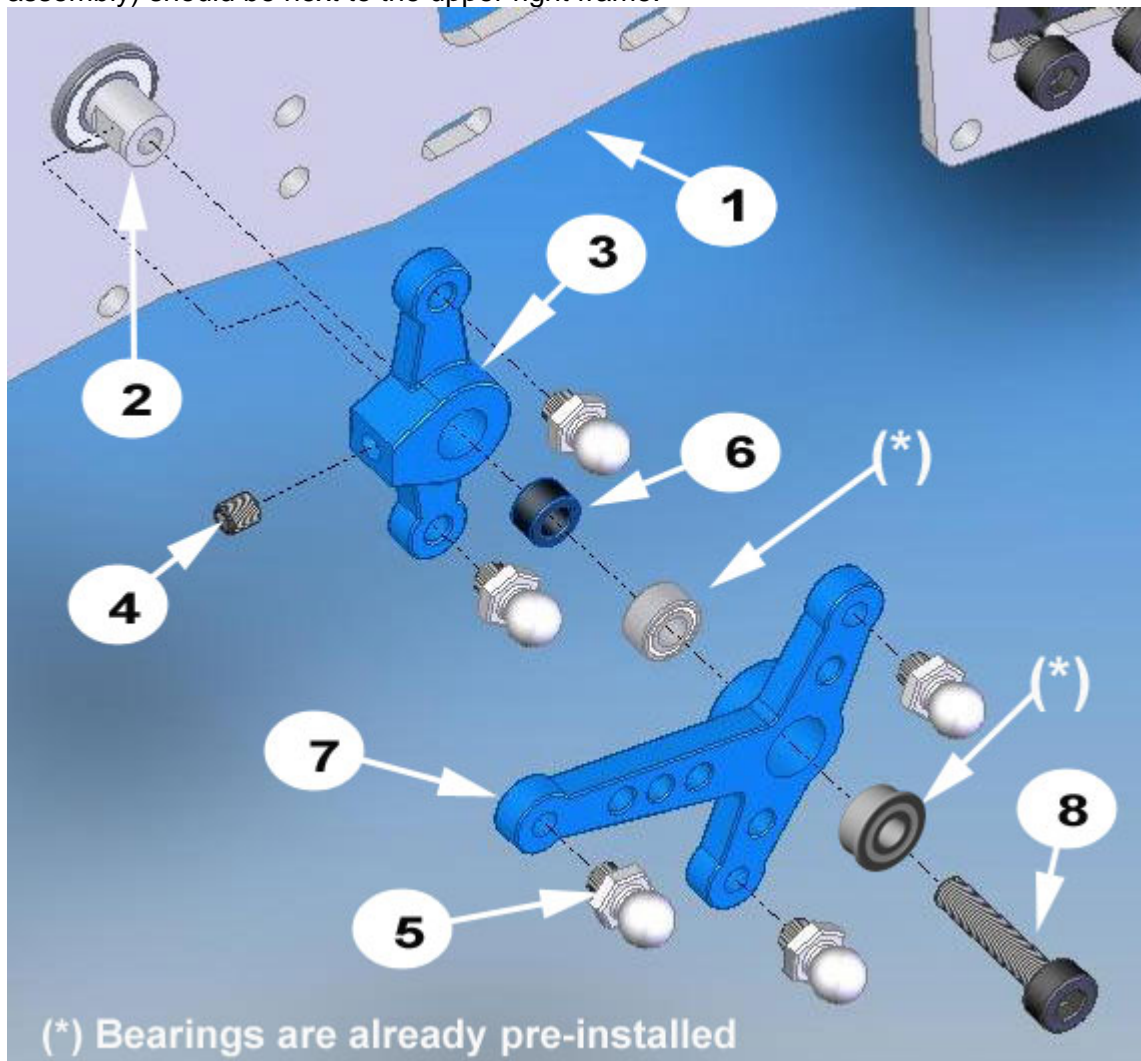

Note: The Elevator Control Shaft is designed to fit tight in the bearings. Sometime, you might have to sand it a little to get it go into the bearings.

1-6-b ANTI-ROTATION GUIDE ASSEMBLY (SPORT MODEL)

No.	Bag#	Description	Qty
1	Step 1-6-a	Right Upper Frame (up to step 1-6-a)	1
2	1	Washout Anti-Rot. Guide	1
3	HB	M3x5x3 Spacer	2
4	HB	M3x45 Cap Head Bolt	2

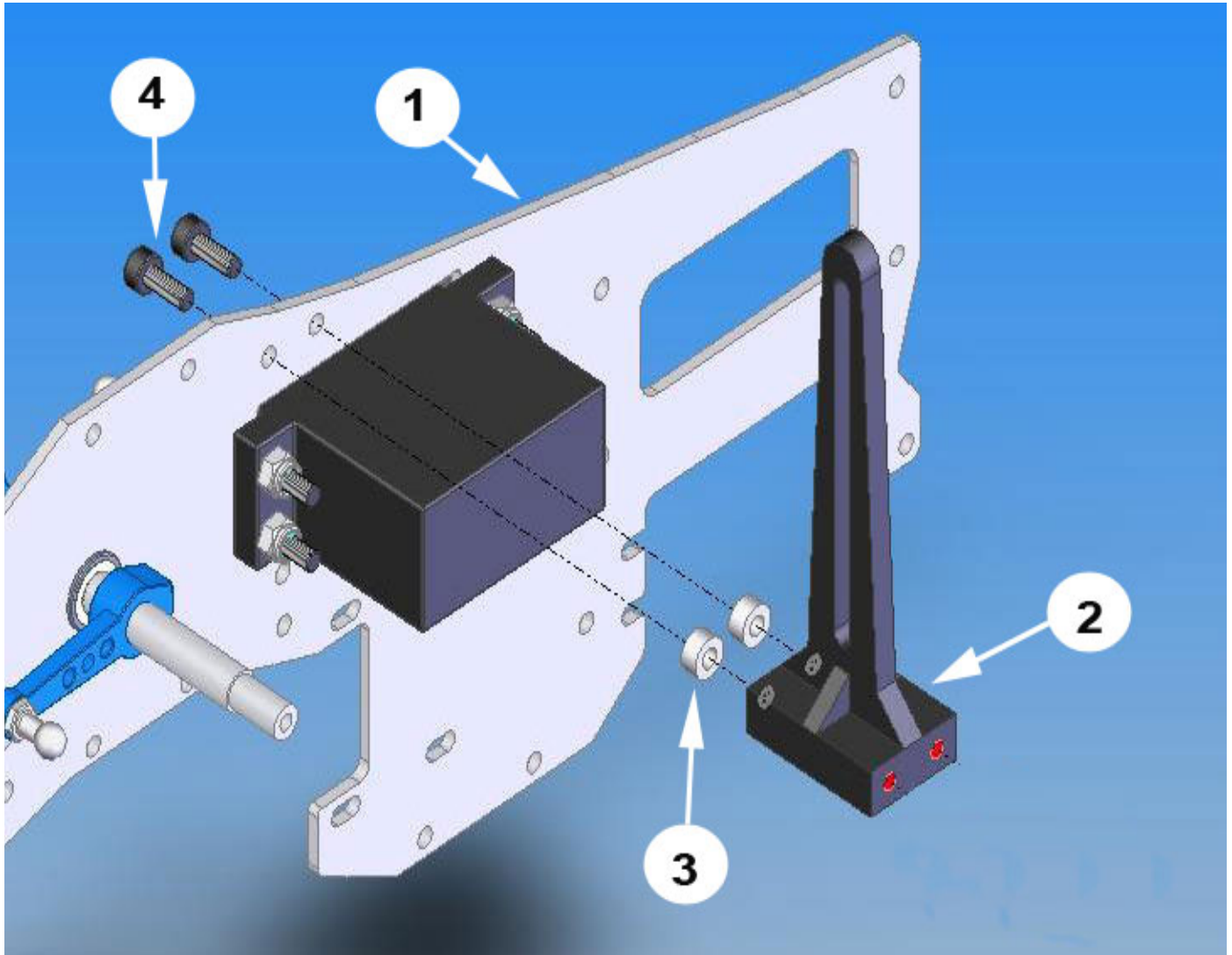

Note: The Elevator Control Shaft is designed to fit tight in the bearings. Sometime, you might have to sand it a little to get it go into the bearings.

1-6-b ANTI-ROTATION GUIDE ASSEMBLY (PRO MODEL)

No.	Bag#	Description	Qty
1	Step 1-6-a	Right Upper Frame (up to step 1-6-a)	1
2	1	Washout Anti-Rot. Guide Base	1
3	Frame	Washout Anti-Rot. Guide A	1
4	HB	M3x5x3 Spacer	2
5	HB	M3x10 Cap Head Bolt	2
6	HB	M3x6 Cap Head Bolt	2

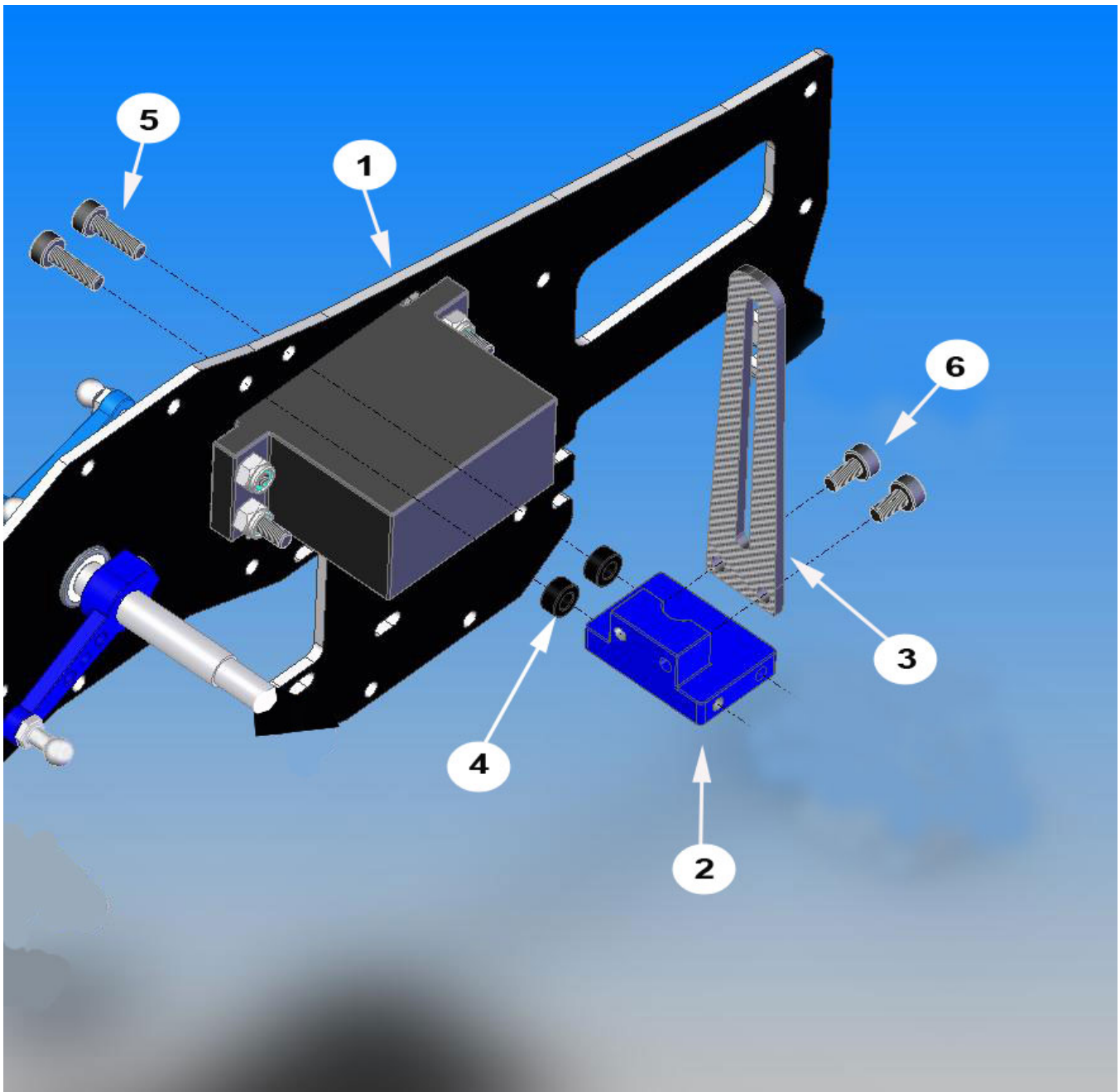

1-6-c MAIN SHAFT BEARING BLOCKS

No.	Bag#	Description	Qty
1	Step 1-6-c	Right Upper Frame (up to step 1-6-b)	1
2	1	Main Shaft Bearing Block	2
3	HB	M3x8 Cap Head Bolt	4

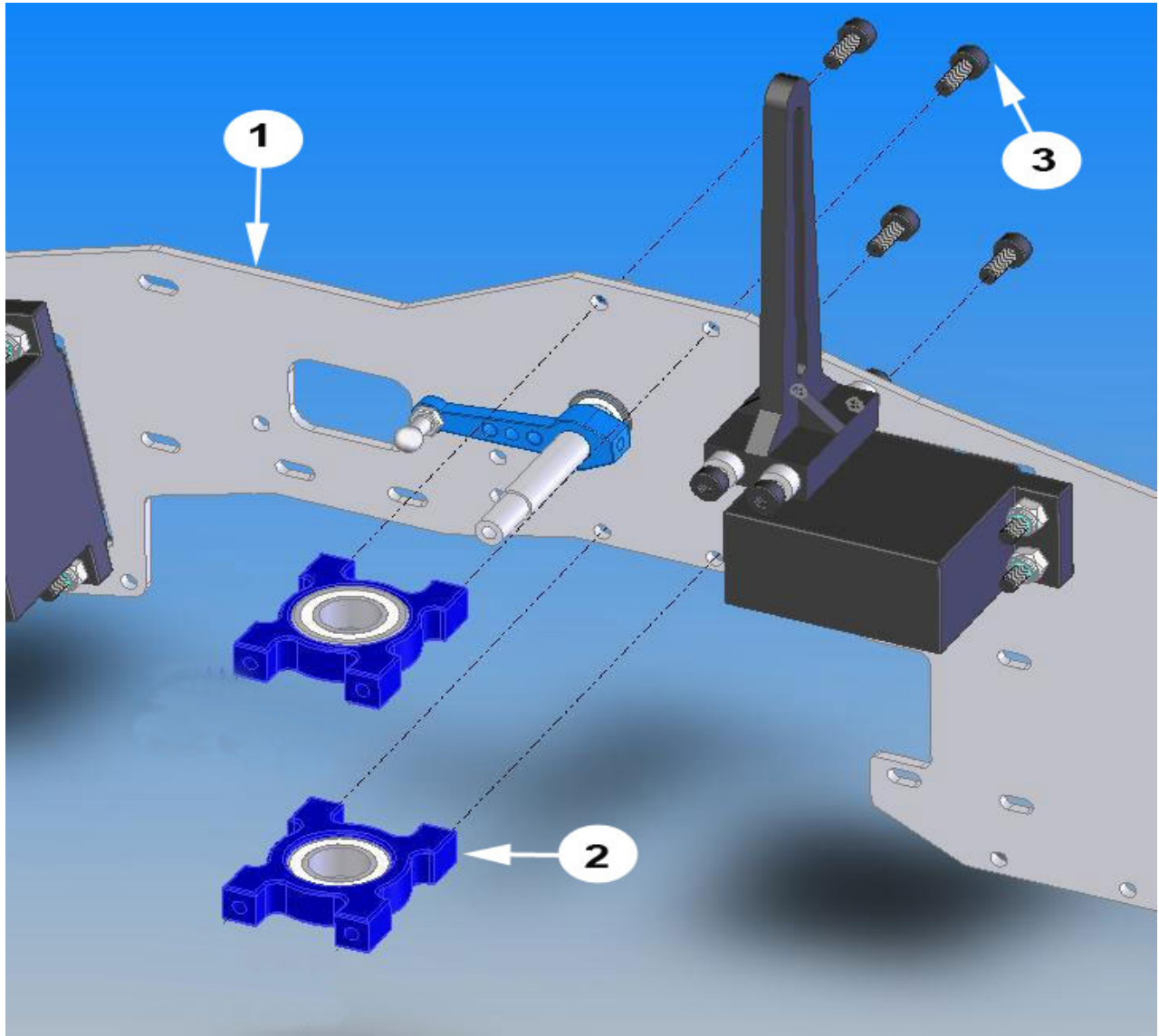

Note: For the Upper Bearing Block, the flange should face down. For the Lower one, the flange should face up.

1-6-d FRAME CROSS MEMBERS, PINION GEAR BEARING BLOCK & TAIL TRANSMISSION

No.	Bag#	Description	Qty
1	Step 1-6-c	Right Upper Frame (up to step 1-6-c)	1
2	Step 1-5	Tail Transmission Subassembly	1
3	1	32mm Cross Member	4
4	1	Clutch Bearing Block	1
5	HB	M3x8 Cap Head Bolt	12
6	Frame	Bulkhead	1
7	1	28mm Cross Member	1
8	1	10mm Spacer	1
9	HB	M3x18 Cap Head Bolt	1
10	HB	M3x7 Flat Washer	6

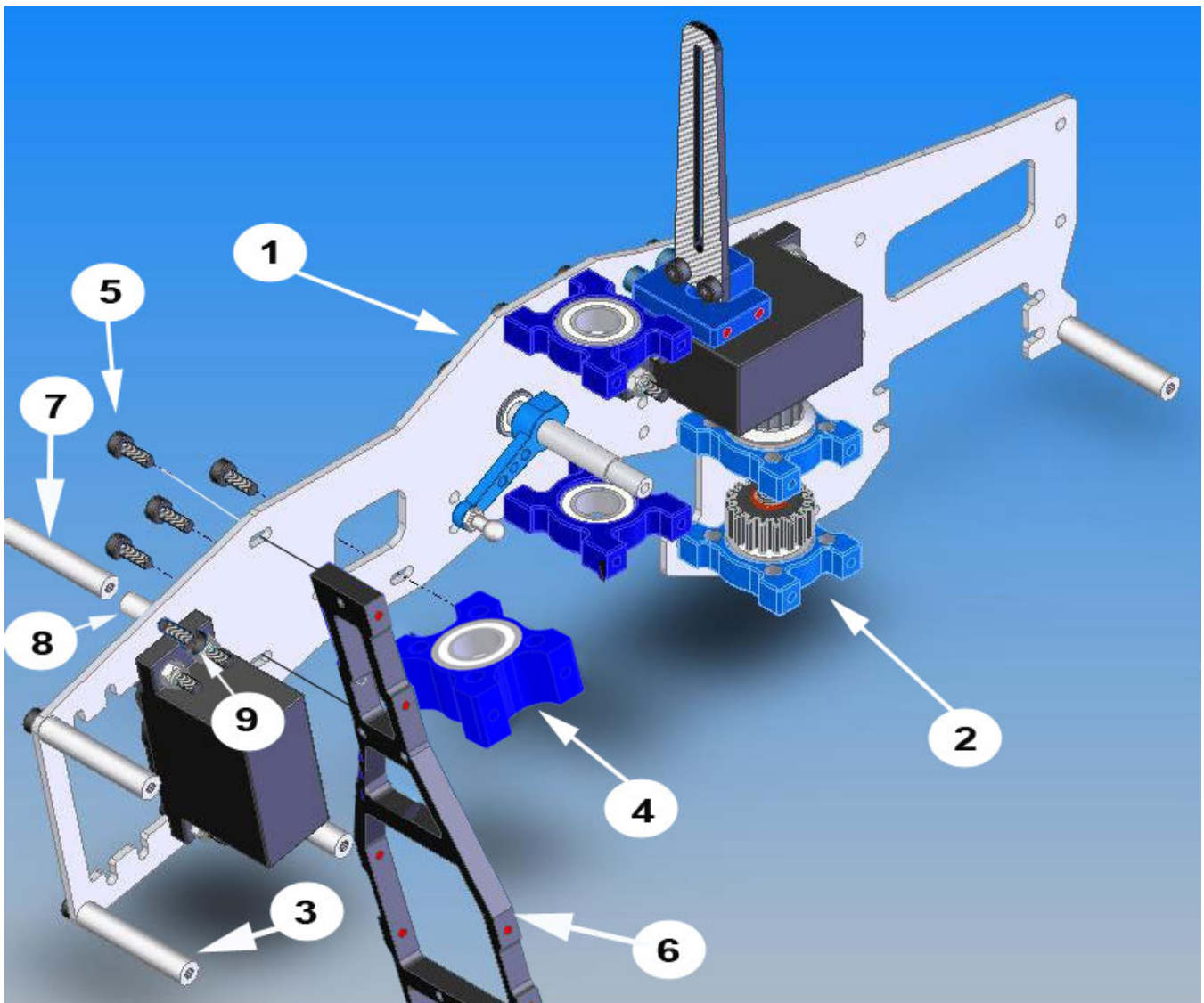

Note: For the Clutch Bearing Block, the side with the smaller bearing should be face up. Use M3x7 Flat Washers when attaching the Clutch Bearing Block and Tail Transmission Subassembly to the frame.

1-6-e UPPER FRAME INSTALLATION

No.	Bag#	Description	Qty	No.	Bag#	Description	Qty
1	Step 1-6-d	Right Upper Frame (up to step 1-6-d)	1	8	HB	M3 Locknut	2*
2	Step 1-2	Left Upper Frame Subassembly	1	9	HB	M3x10 Cap Head Bolt	2**
3	HB	M3x5x3 Spacer	2	10	1	28mm Cross Member	1
4	1	Left Aileron Control Lever	1	11	1	10mm Spacer	1
5	HB	M3x4 Pivot Ball Stud	3	12	HB	M3x18 Cap Head Bolt	1
6	HB	M3x8 Cap Head Bolt	17	13	HB	M3x7 Flat Washer	6
7	HB	M3x12 Cap Head Bolt	1				

*Note: Pro Version does not need these.

**Note: Sport Version does not need these.

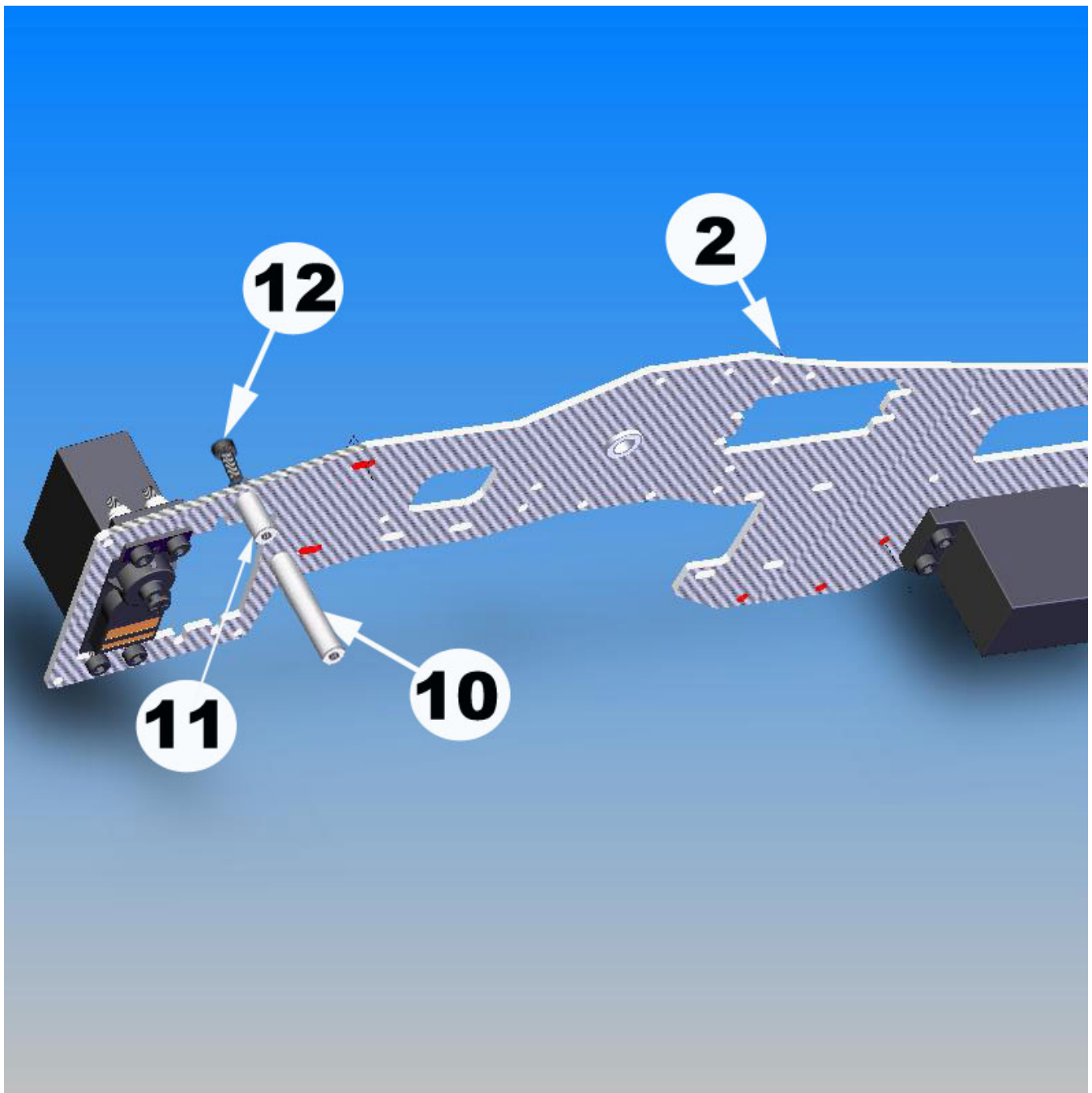

Attach the right side and left side together using M3x8 Cap Head Bolts. Remember to use M3x7 Flat Washers for attaching the Clutch Bearing Block and Tail Transmission Subassembly to the frame. Note: The Elevator Control Shaft is designed to fit tight in the bearings. Sometime, you might have to sand it a little to get it go into the bearings.

Note: The Elevator Control Shaft is designed to fit tight in the bearings. Sometime, you might have to sand it a little to get it go into the bearings.

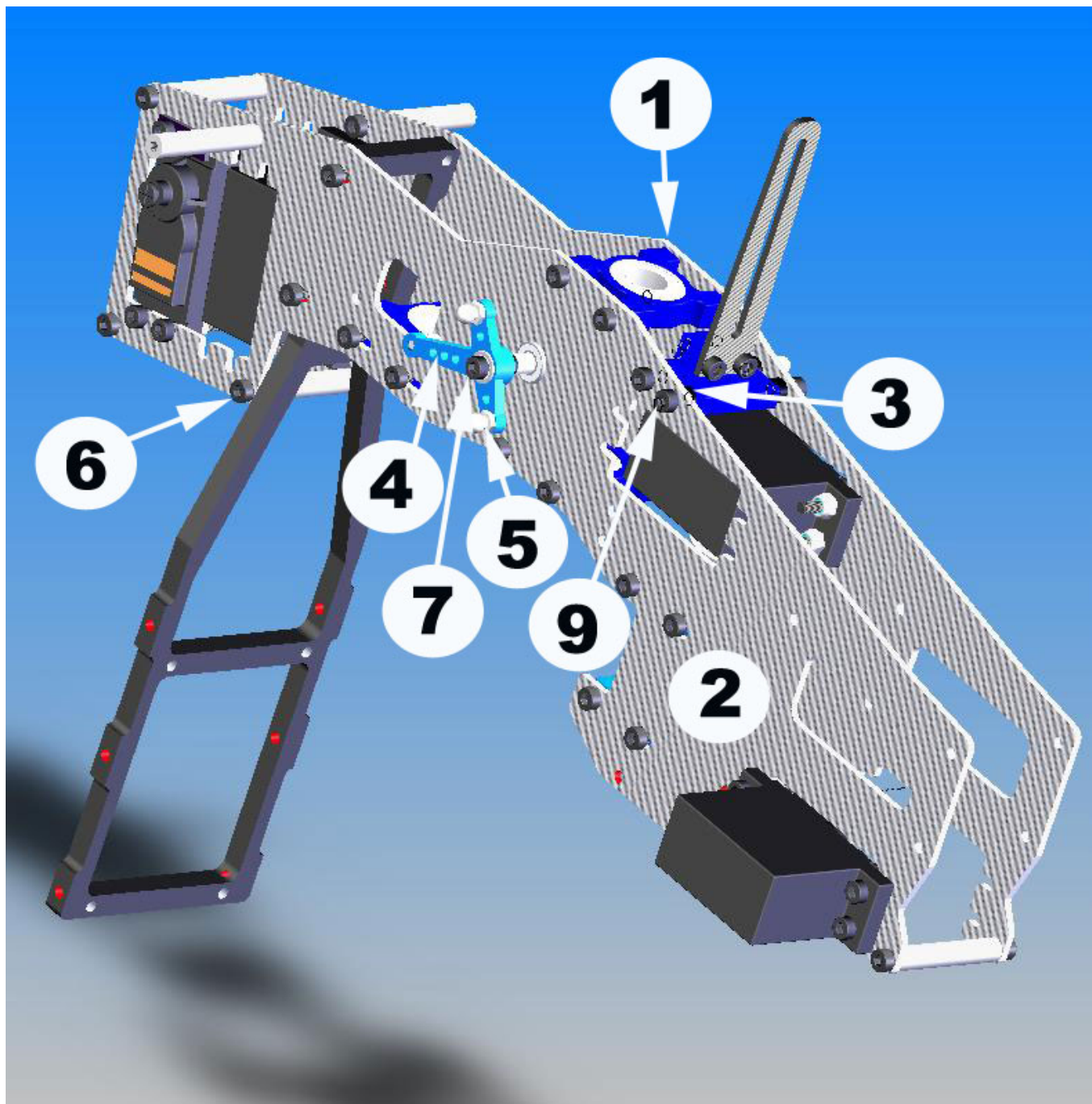

1-7 CLUTCH BELL ASSEMBLY

No.	Bag#	Description	Qty
1	1	Pinion Gear	1
2	1	Clutch Bell	1
3	1	Clutch Shoe Lining	1
4	HB	M4x4 Set Screw	1
5	1	Start Coupler	1
6	1	Start Shaft	1
7****		Electric Tape	1

Install (1) Clutch Lining into (1) Clutch Bell. **Note:** The recommended adhesives for installing the clutch lining are JB Weld or 10 Min + Epoxy. Prepare the clutch bell by scuffing the interior with an x-acto blade or sand paper. Put the Clutch Lining in the Clutch Bell and mark it for cutting (the length is around 134mm). Cut the Clutch Lining. Apply the adhesive thin and even and finish the installation by inserting and finishing the clutch lining. Trick: Use electric tape wrap around the Clutch Shoe (in bag # 2) one time. Then insert the Clutch Shoe into the Clutch Bell. Clean up any excess adhesive. Let it sit there until the adhesive dry out then take the Clutch Shoe and electric tape off. See the label on the adhesive bottle for drying time.

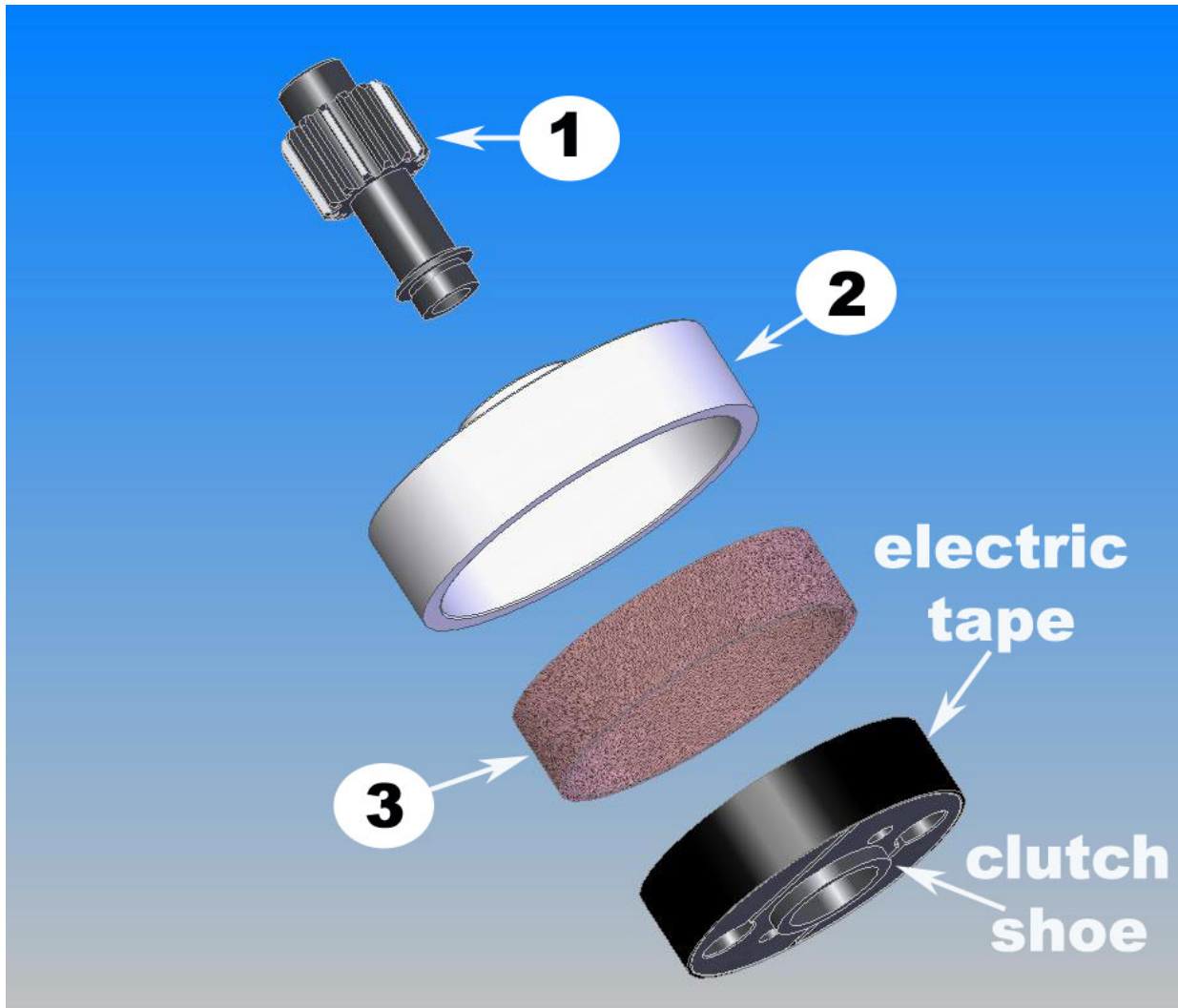

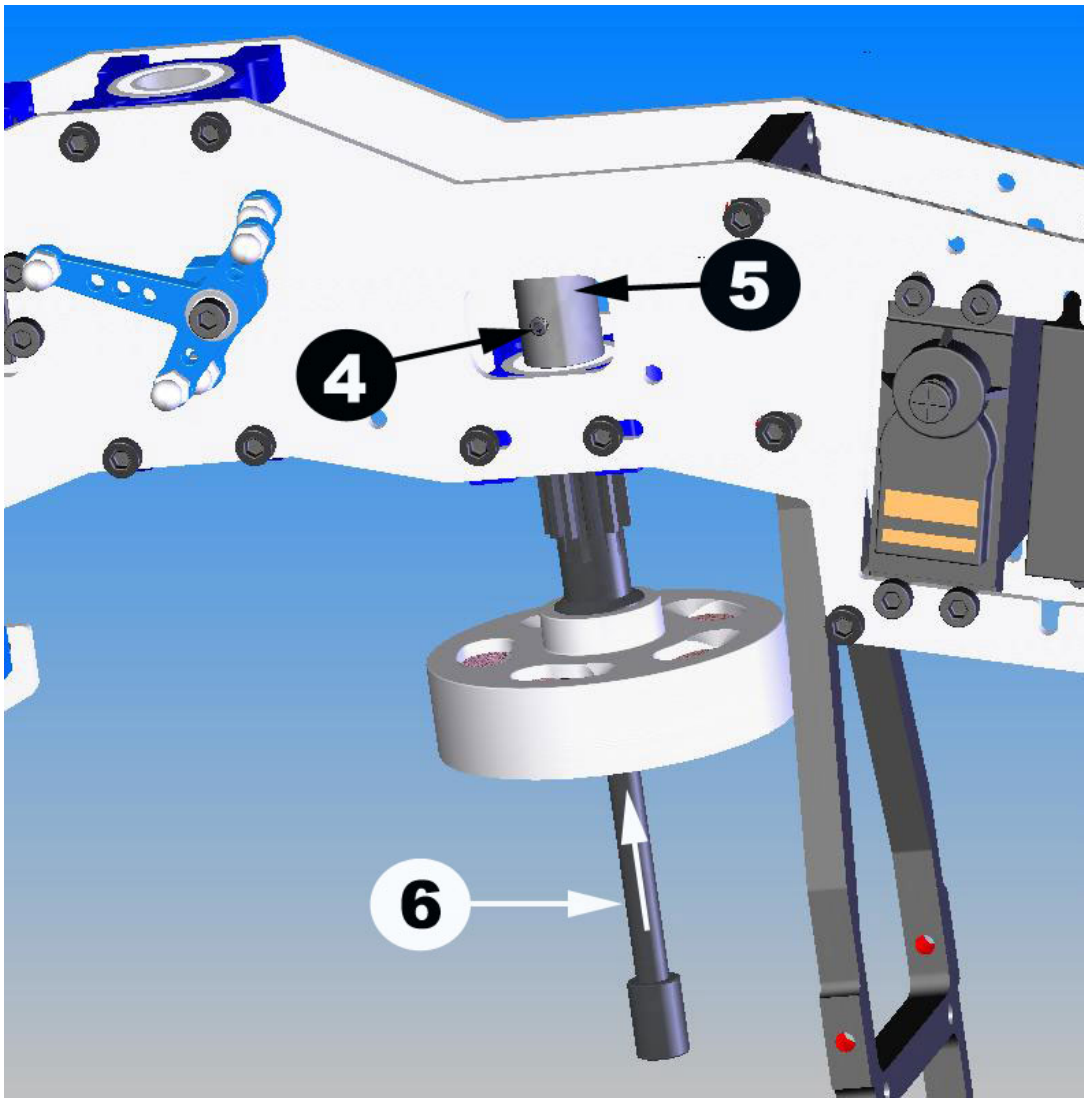

Note: It is very important to use a Dialing Indicator to check the run out of the Clutch Bell. The run out should be no more than 0.004 inch (0.10 mm).

2-1 RADIO TRAY ASSEMBLY

No.	Bag#	Description	Qty
1	Frame	Front Lower Frame	2
2	Frame	Radio Tray	1
3	2	Long Canopy Standoff	2
4	2	60mm Cross Member	1
5	HB	M3x8 Cap Head Bolt	4
6	HB	M3X10 Cap Head Bolt	4
7	HB	M3x5x3 Spacer	4
8	2	M3x6x10 Spacer	2
9	HB	M3x18 Cap Head Bolt	2

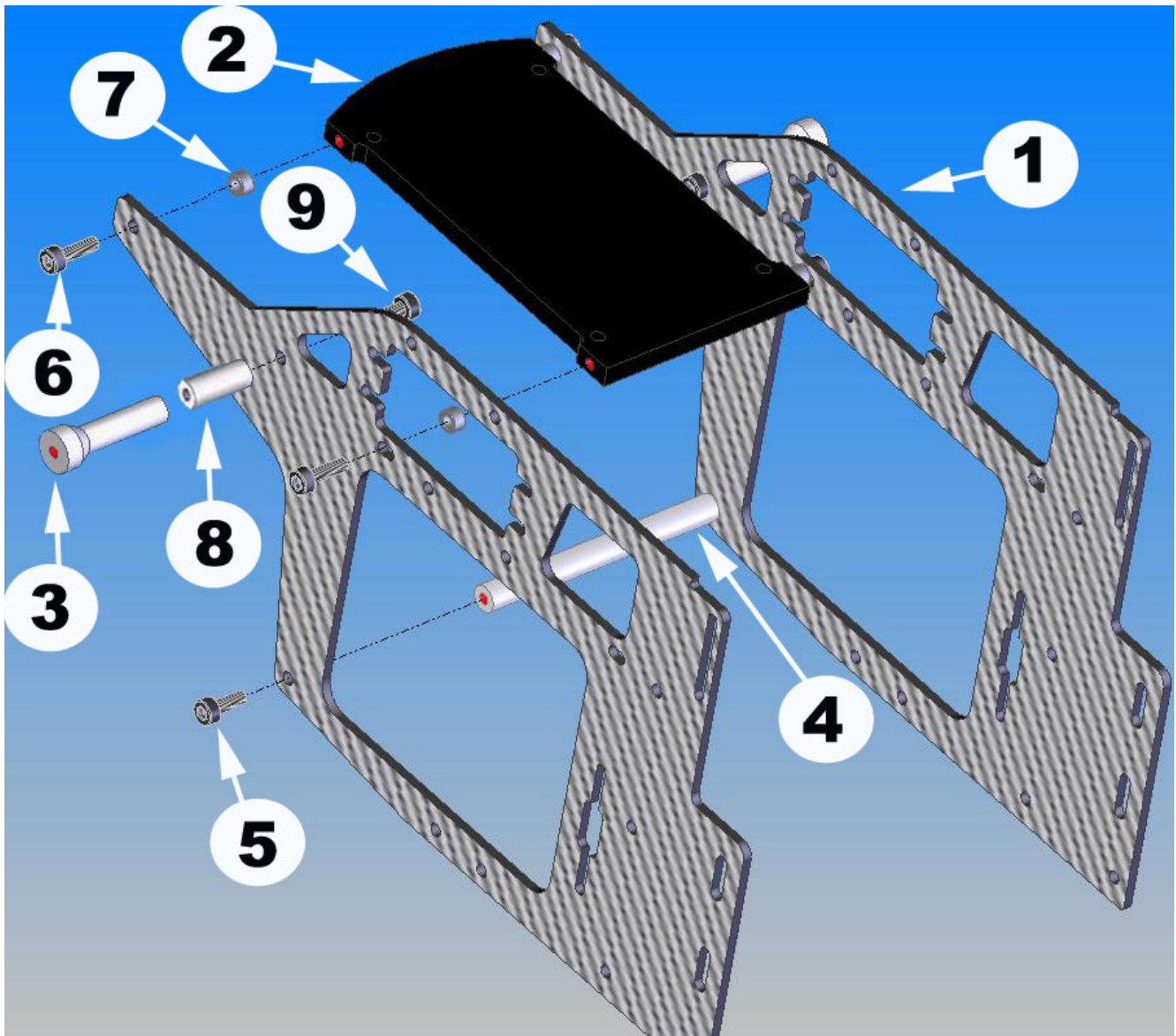

2-2 FUEL TANK ASSEMBLY

No.	Bag#	Description	Qty
1	Loose in box	Tank Clunk	1
2****		12 cm Hose	1
3	Loose in box	Long Tube	2
4	Loose in box	Tank Rubber Plug	1
5	Loose in box	Short Tube	1
6	Loose in box	Tank Fuel Plug Bottom Flange	1
7	Loose in box	Tank Fuel Plug Top Flange	1
8	Loose in box	M3x25 Cap Head Bolt	1
9	Loose in box	Fuel Tank	1

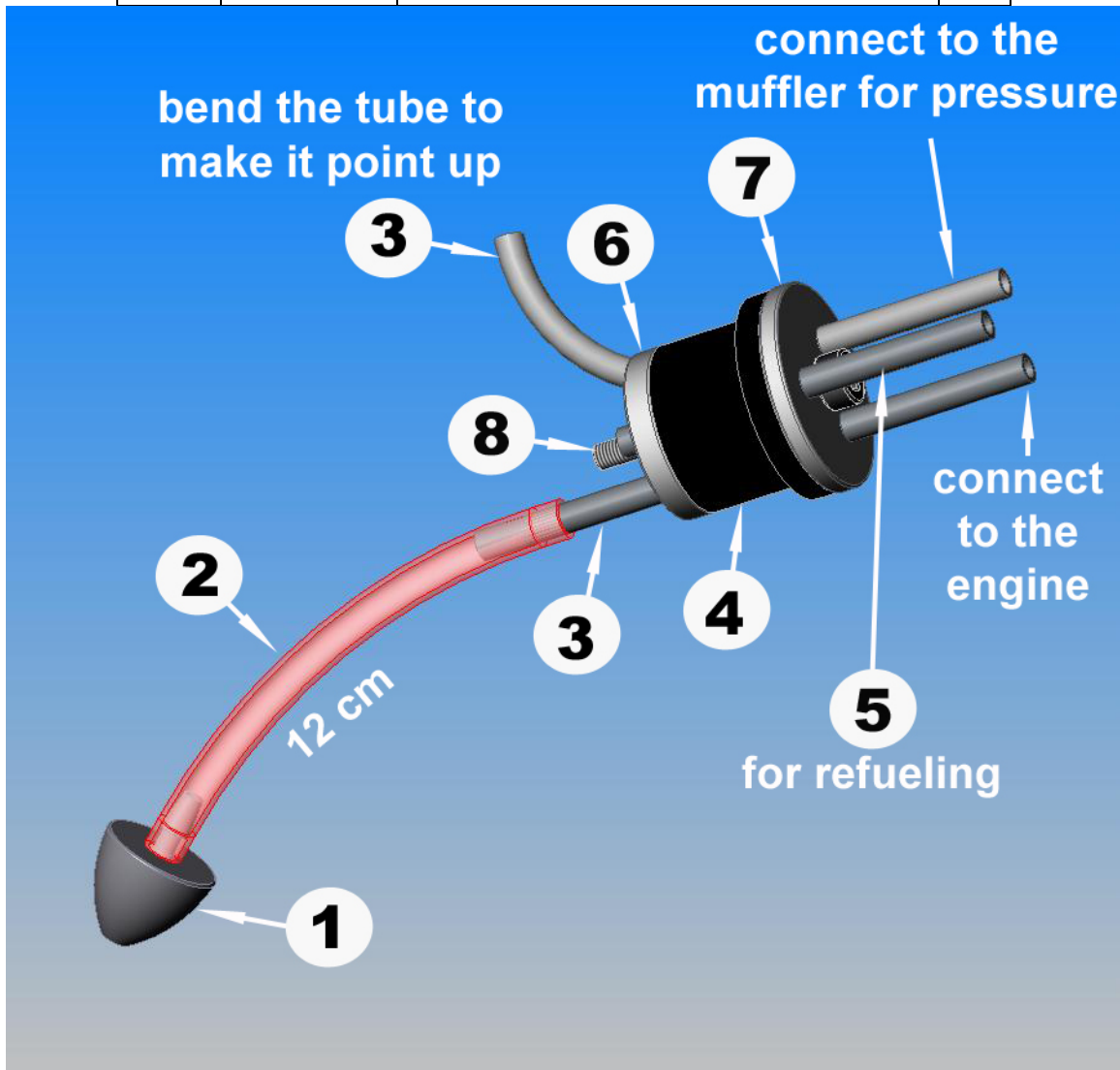

- There are three (3) lines (Aluminum fuel tubing) that need to be constructed for the tank assembly. Depending on the engine you use, you may need only two (2) lines. One line is the fuel pick-up line and requires a length of silicon fuel tubing running from end of alum. Tube to clunk – which should be centered in tank. The other line is pressure-line, which should be bent to reach the top of the tank on the inside. The third line will generally be plugged. Tighten rubber stopper screw – but do not tighten much.

- Insert the whole construction into the Fuel Tank. Continue tightening but do not over tighten or you will ruin rubber stopper!

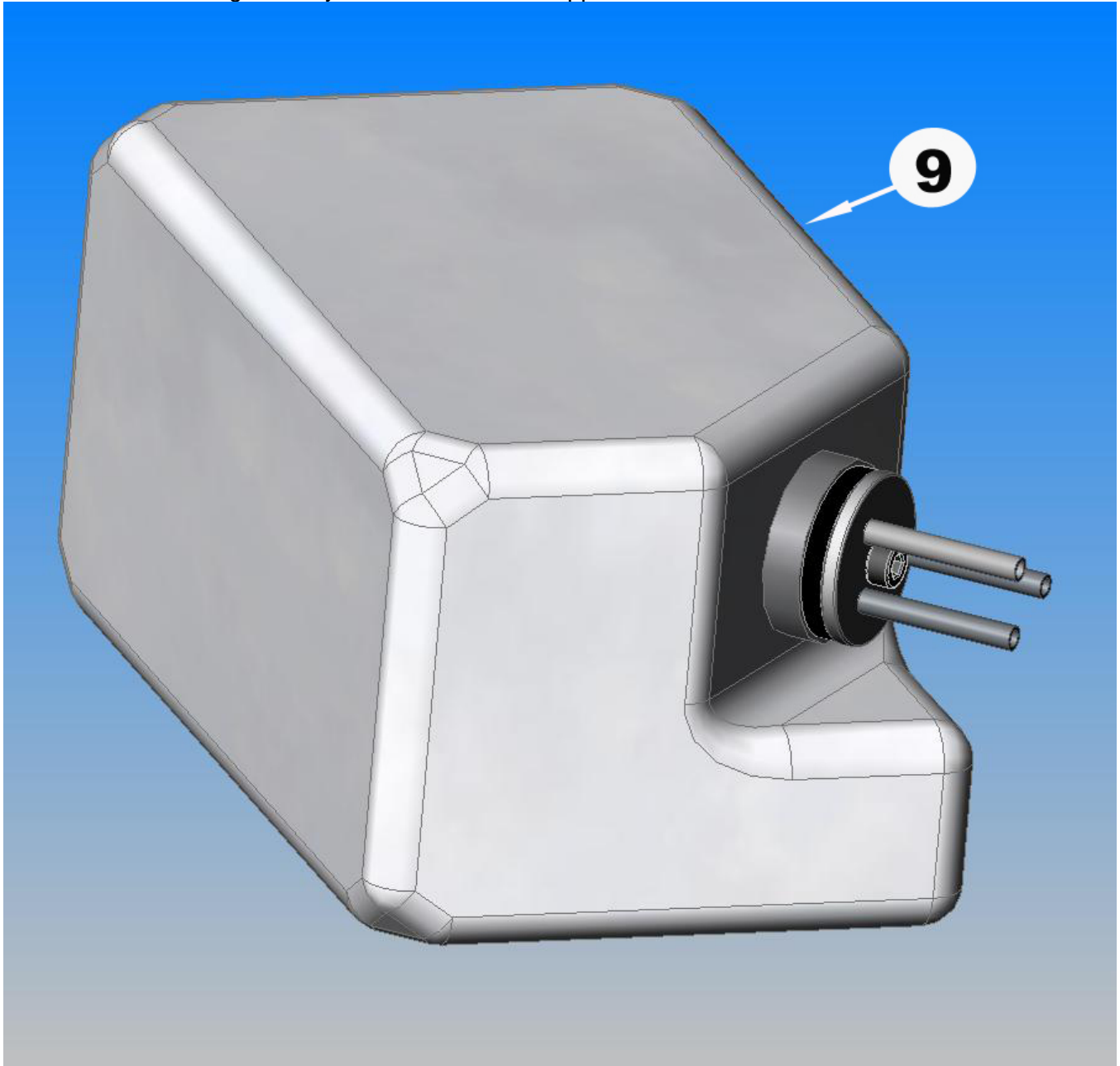

2-3 FUEL TANK INSTALLATION

No.	Bag#	Description	Qty
1	Step 2-1	Radio Tray Assembly	1
2	Step 2-2	Fuel Tank Assembly	1
3	2	Half Round Cross Member	1
4****		Double Side Tape	1
5	HB	M3x8 Cap Head Bolt	2

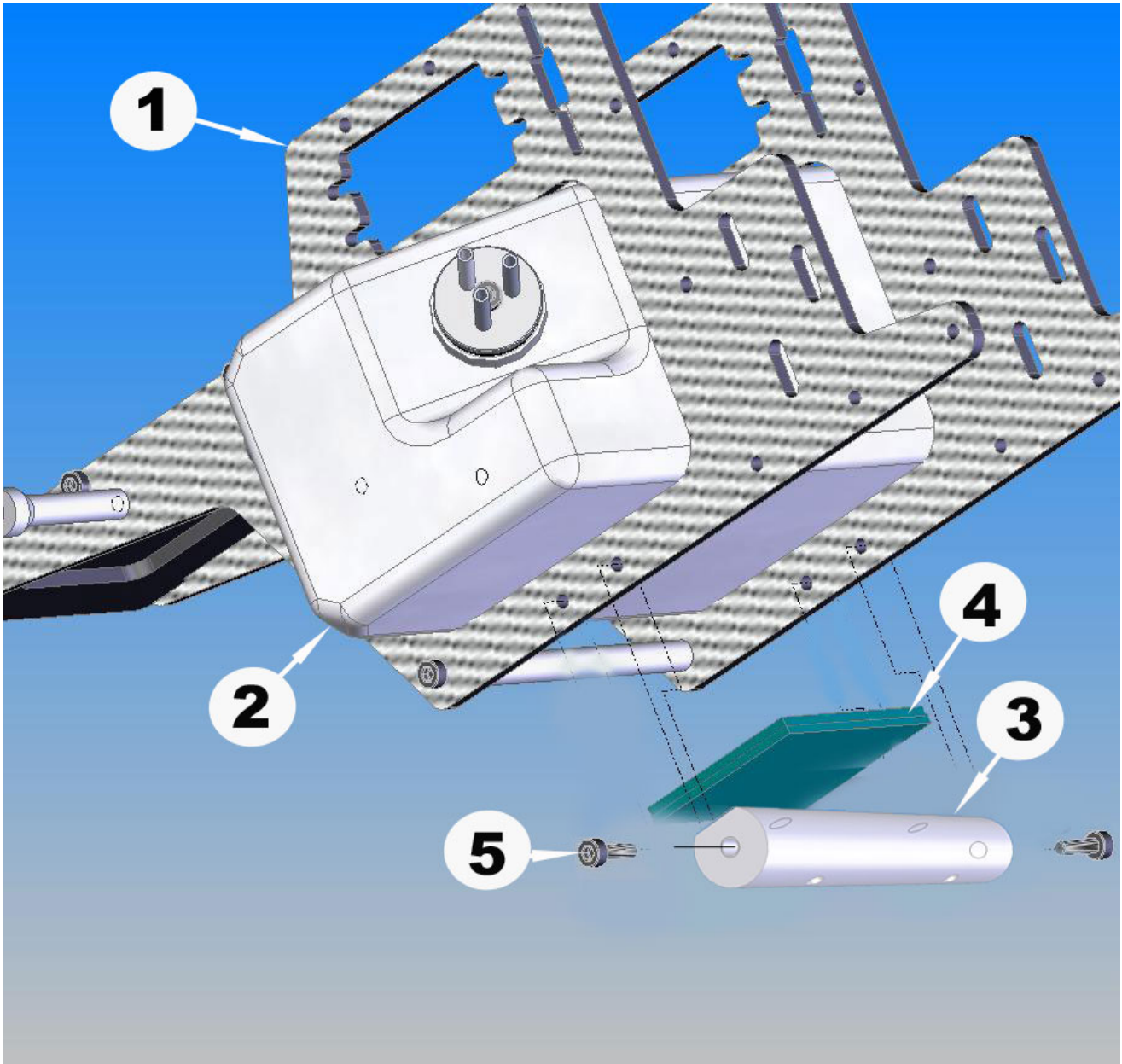

2-4 THROTTLE SERVO ASSEMBLY

No.	Bag#	Description	Qty
1	Step 2-3	Fuel Tank Installation	1
2****		Servo	1
3	HB	M2.5x14 Cap Head Bolt	4
4	HB	M2.5 Locknut	4

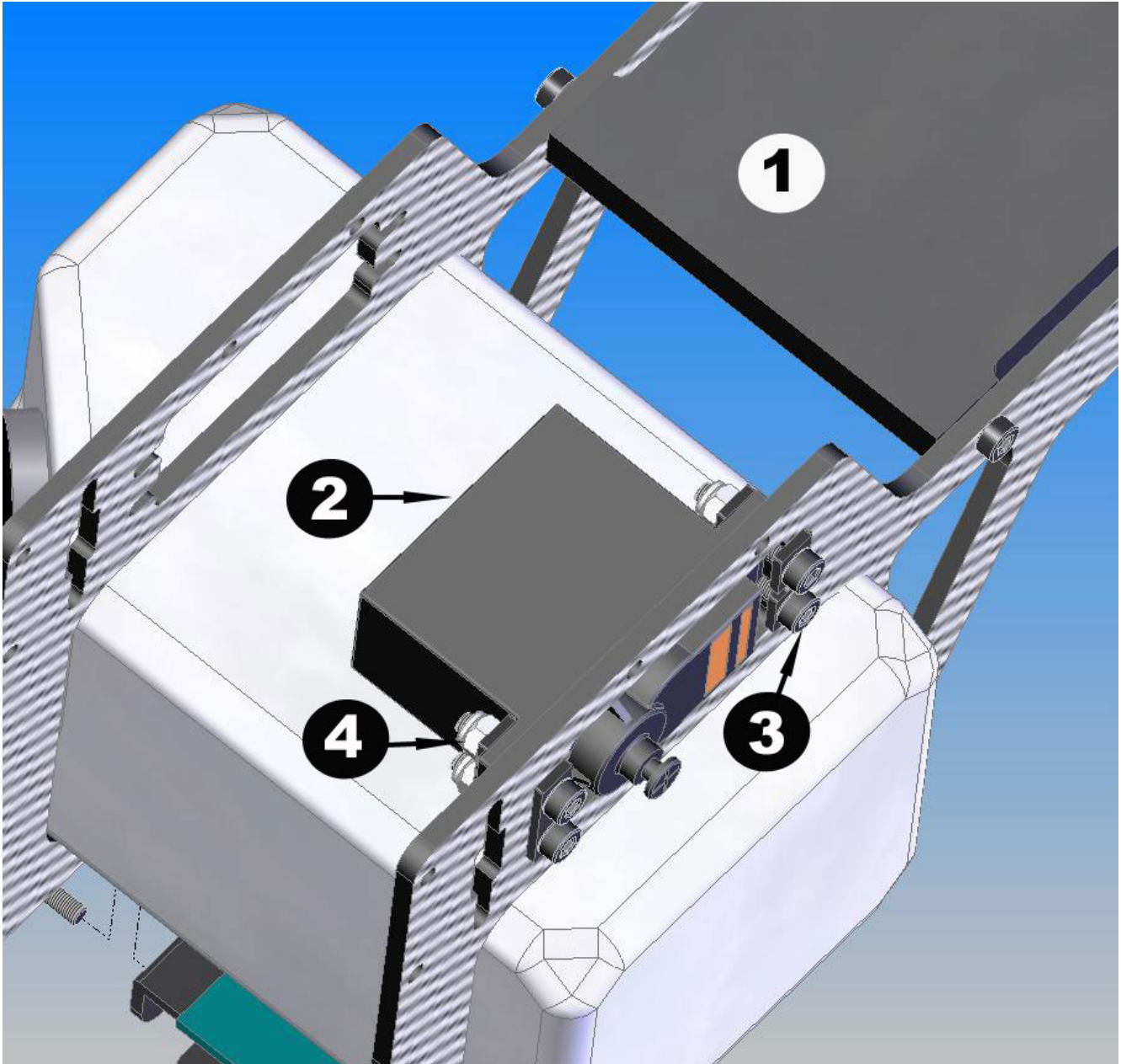

2-5 LOWER FRAME INSTALLATION

No.	Bag#	Description	Qty
1	Step 1	Upper Frame Assembly	1
2	Step 2-4	Lower Frame Assembly	1
3	Frame	Rear Frame	2
4	Frame	Gyro Tray	1
5	2	One-piece Cross Member	2
6	2	32mm Cross Member	3
7	HB	M3x20 Cap Head Bolt	6
8	HB	M3x5x3 Spacer	4
9	HB	M3x10 Cap Head Bolt	4
10	HB	M3x8 Cap Head Bolt	4

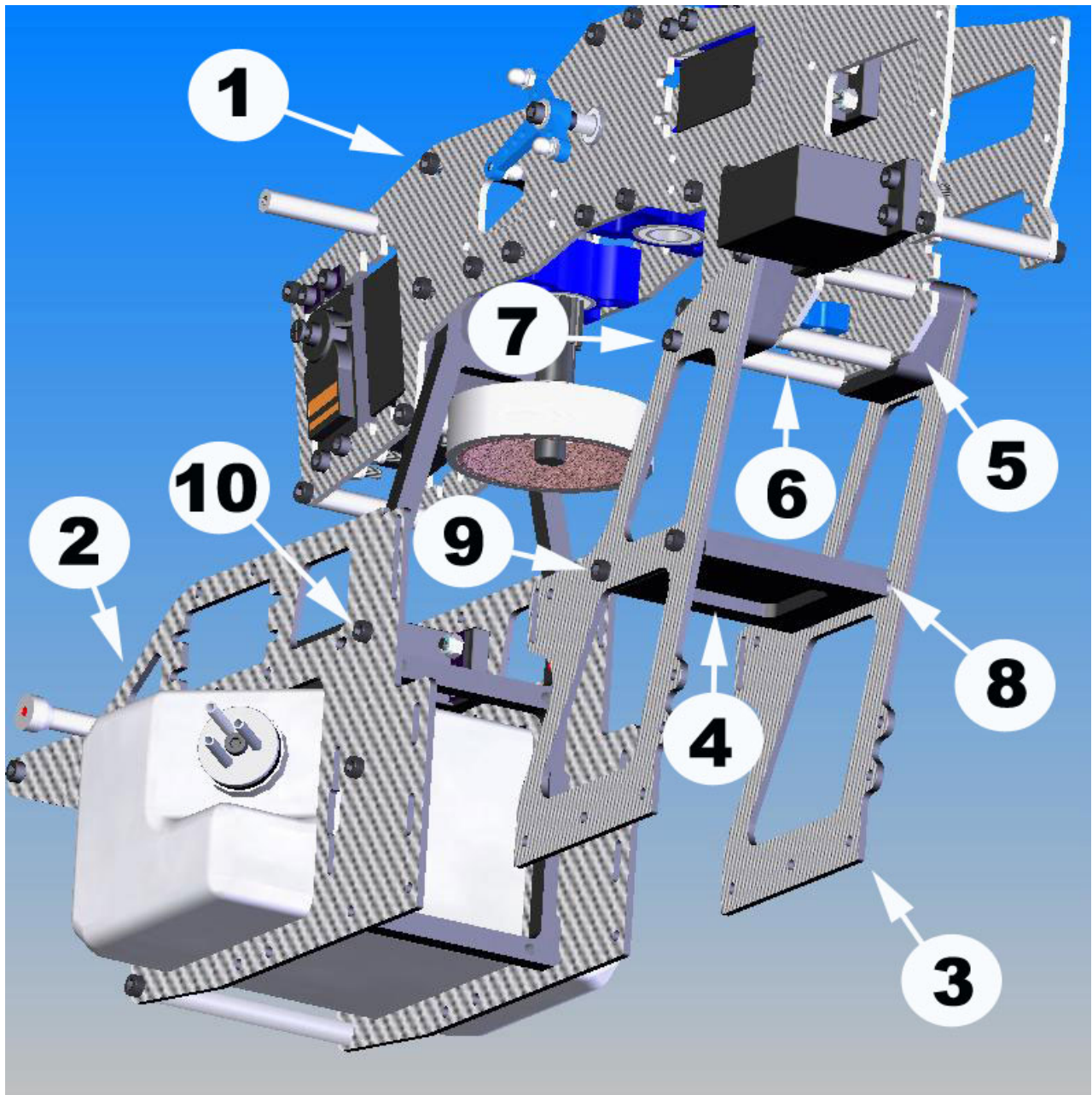

2-6 FRAME ANGLE & SHROUD ASSEMBLY

No.	Bag#	Description	Qty
1	Loose in box	Fan Shroud	1
2	2	M2.5x6 Self Taping Screw	4
3	Frame	Frame Angle	2
4	2	60 mm Cross Member	1
5	HB	M3x10 Cap Head Bolt	4
6	HB	M3x8 Cap Head Bolt	4
7	HB	M3 Locknut	4

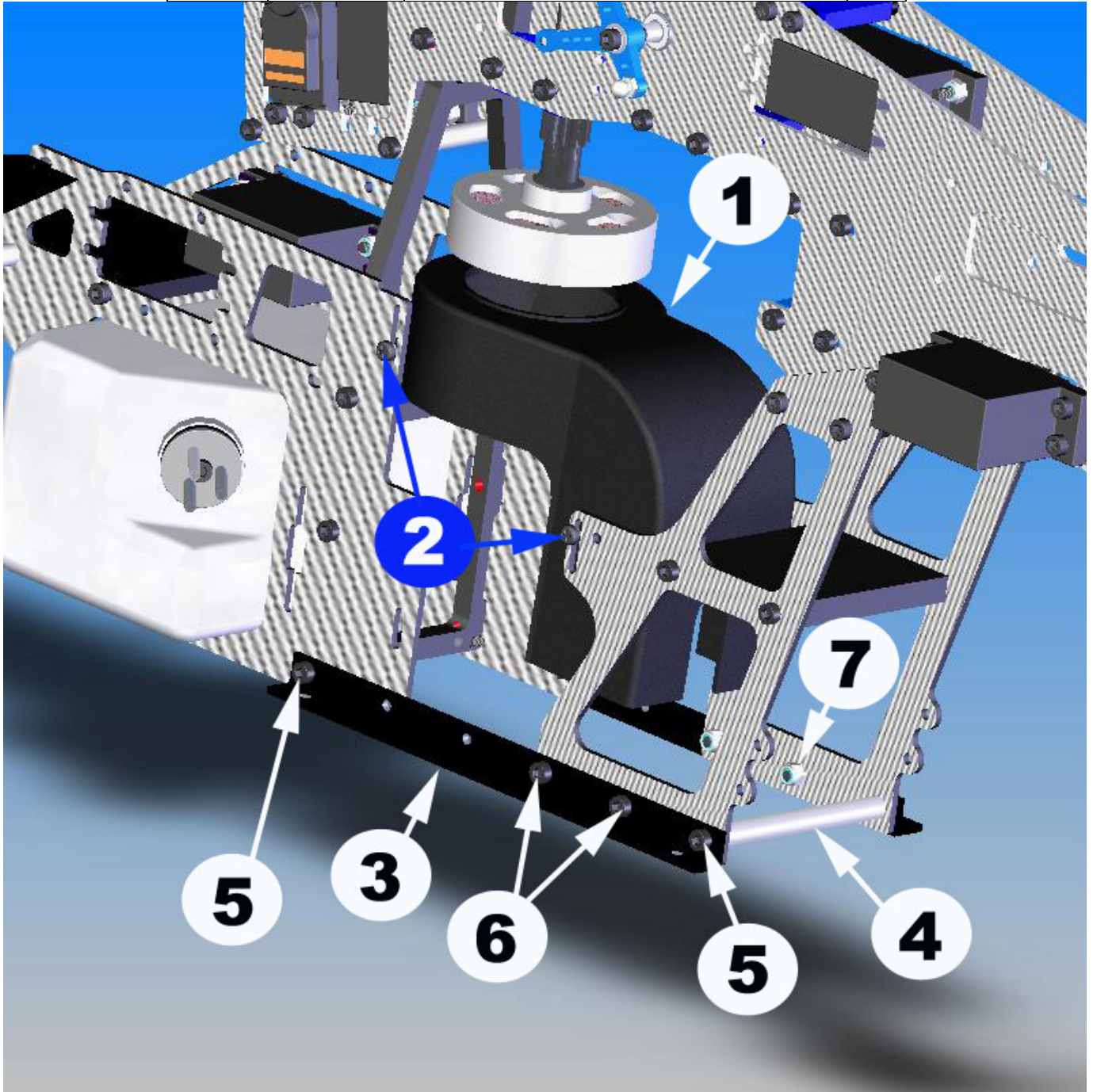

2-7 ENGINE ASSEMBLY

No.	Bag#	Description	Qty
1****		Engine	1
2	2	Fan Hub	1
3	2	Cooling Fan	1
4	HB	M3x6 Cap Head Bolt	6
5	2	Engine Hub Collect	1
6	HB	M6 Nord-Loc Washer	2
7****		M6 Hex Nut	1
8	2	Clutch Shoe	1
9	2	Engine Mount	1
10	HB	M3x10 Cap Head Bolt	4

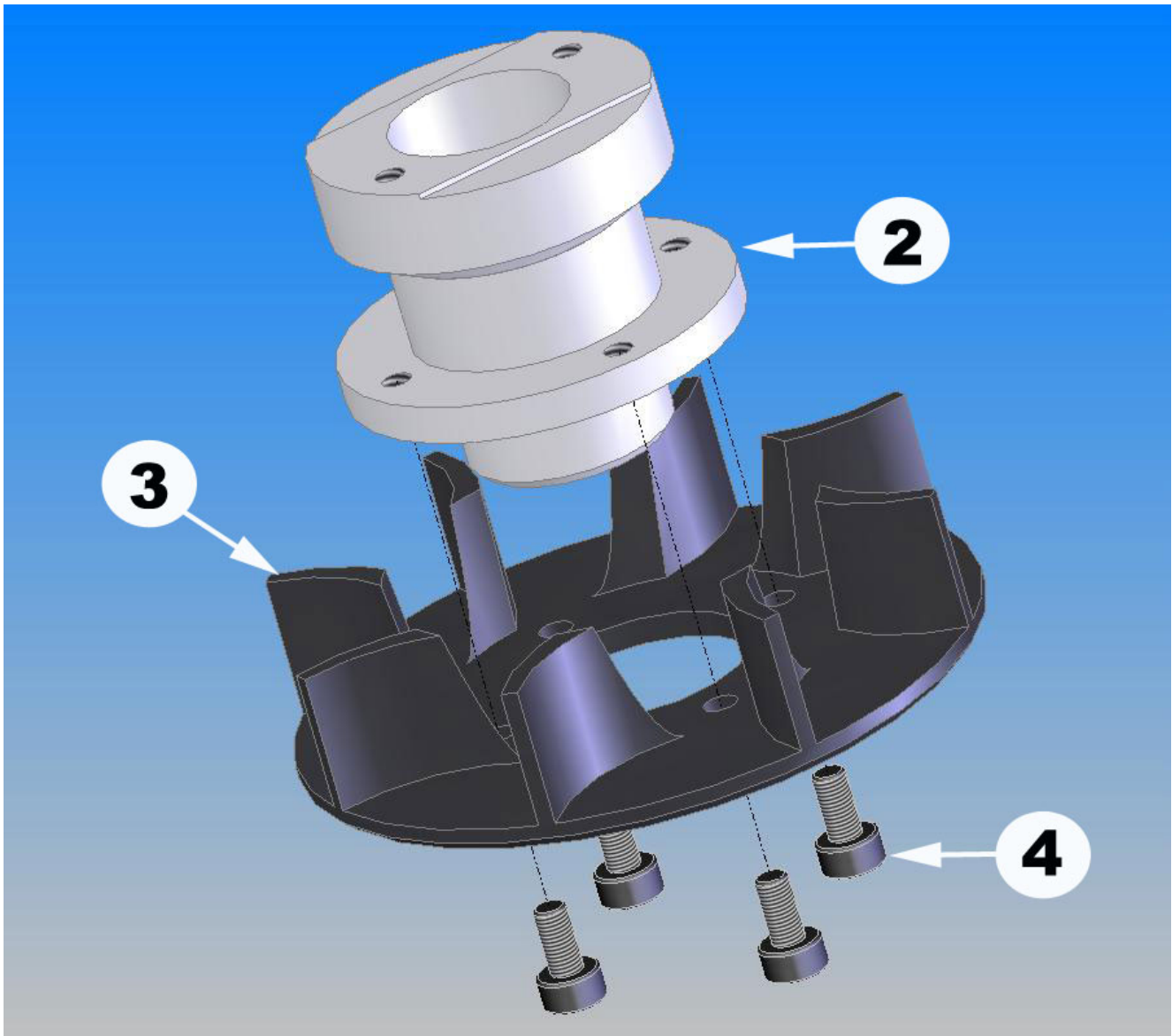

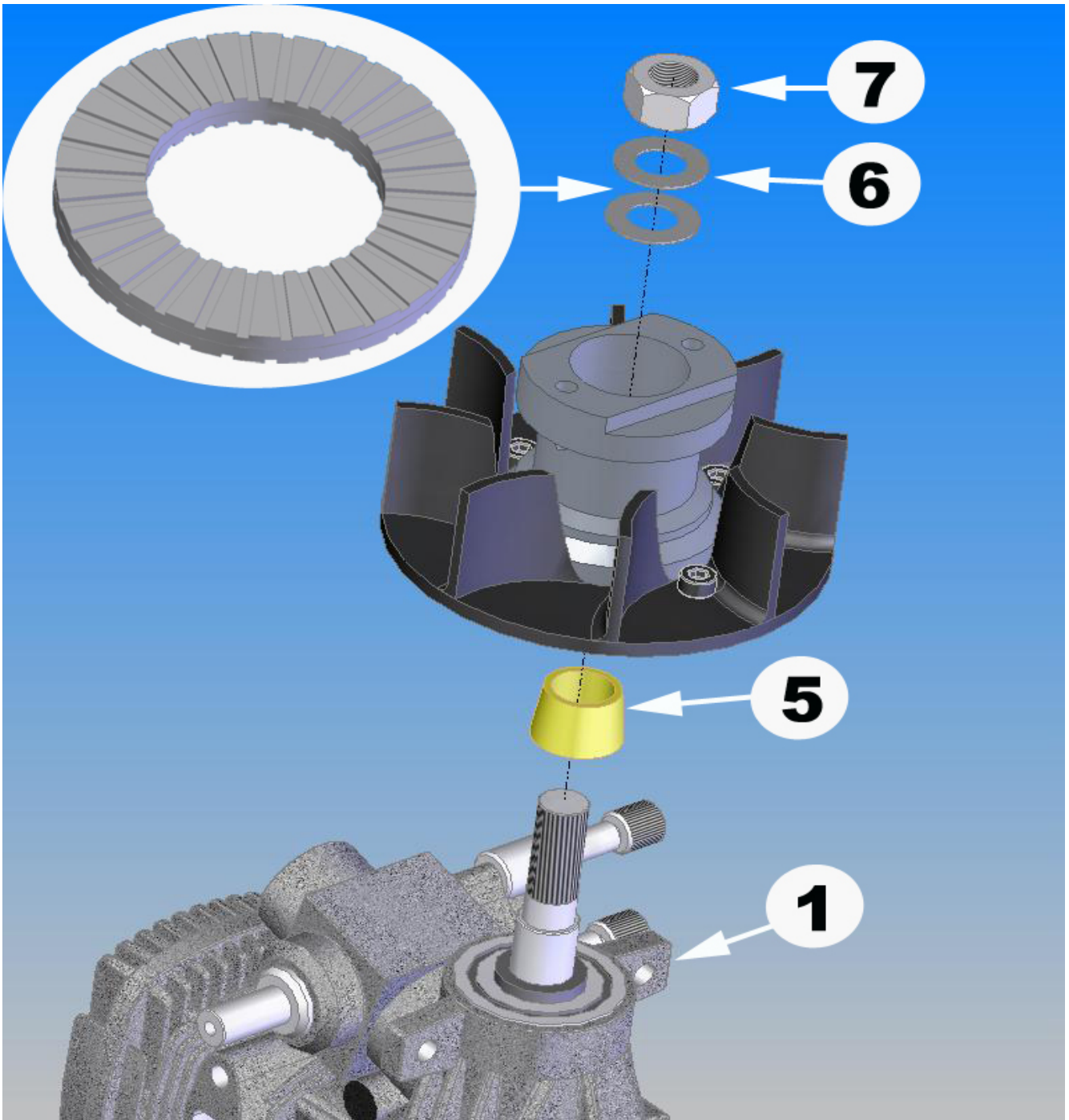

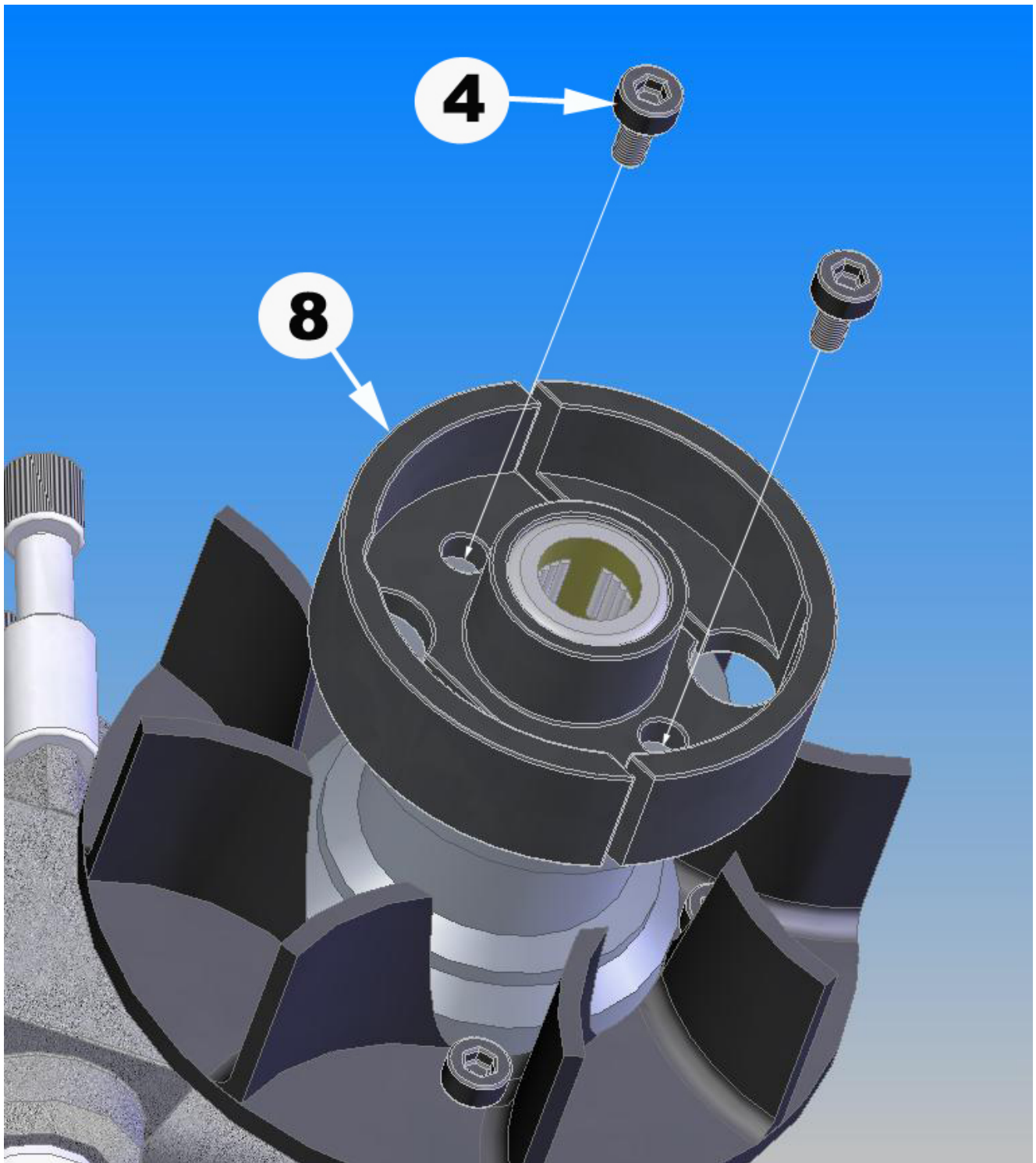

Note: it is very important to use a Dialing Indicator to check the run out of the Engine Assembly. Most of the vibration problems come from this. The run out should be no more than 0.004 inch (0.10 mm).

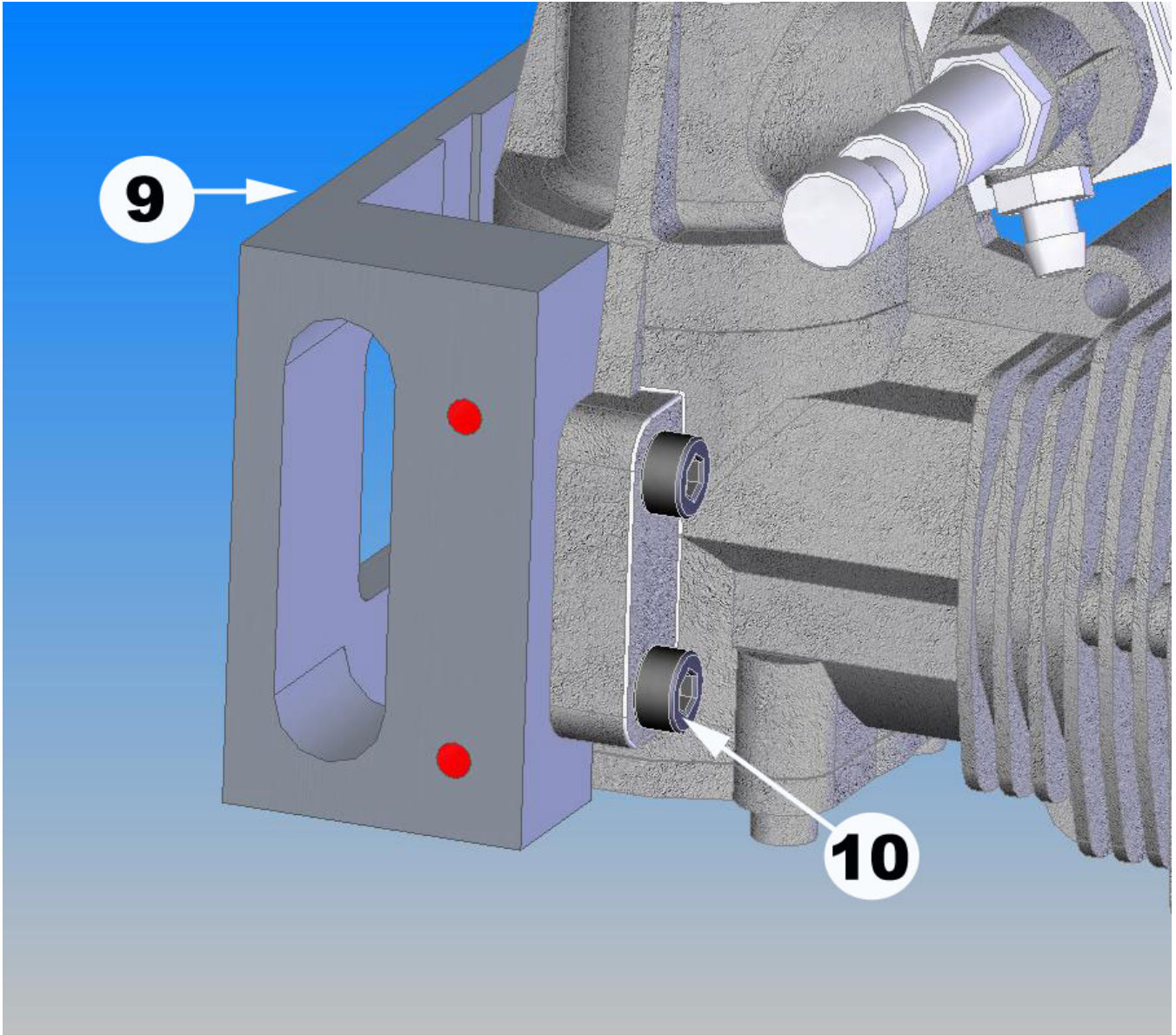

Note: Engine Mount may look differently from the one in the kit.

2-8 ENGINE INSTALLATION

No.	Bag#	Description	Qty
1	Step 2-7	Engine Assembly	1
2	Step 2-6	Assembly up to step 2-6	1
3	HB	M3x10 Cap Head Bolt	4
4	HB	M3 Flat Washer	4

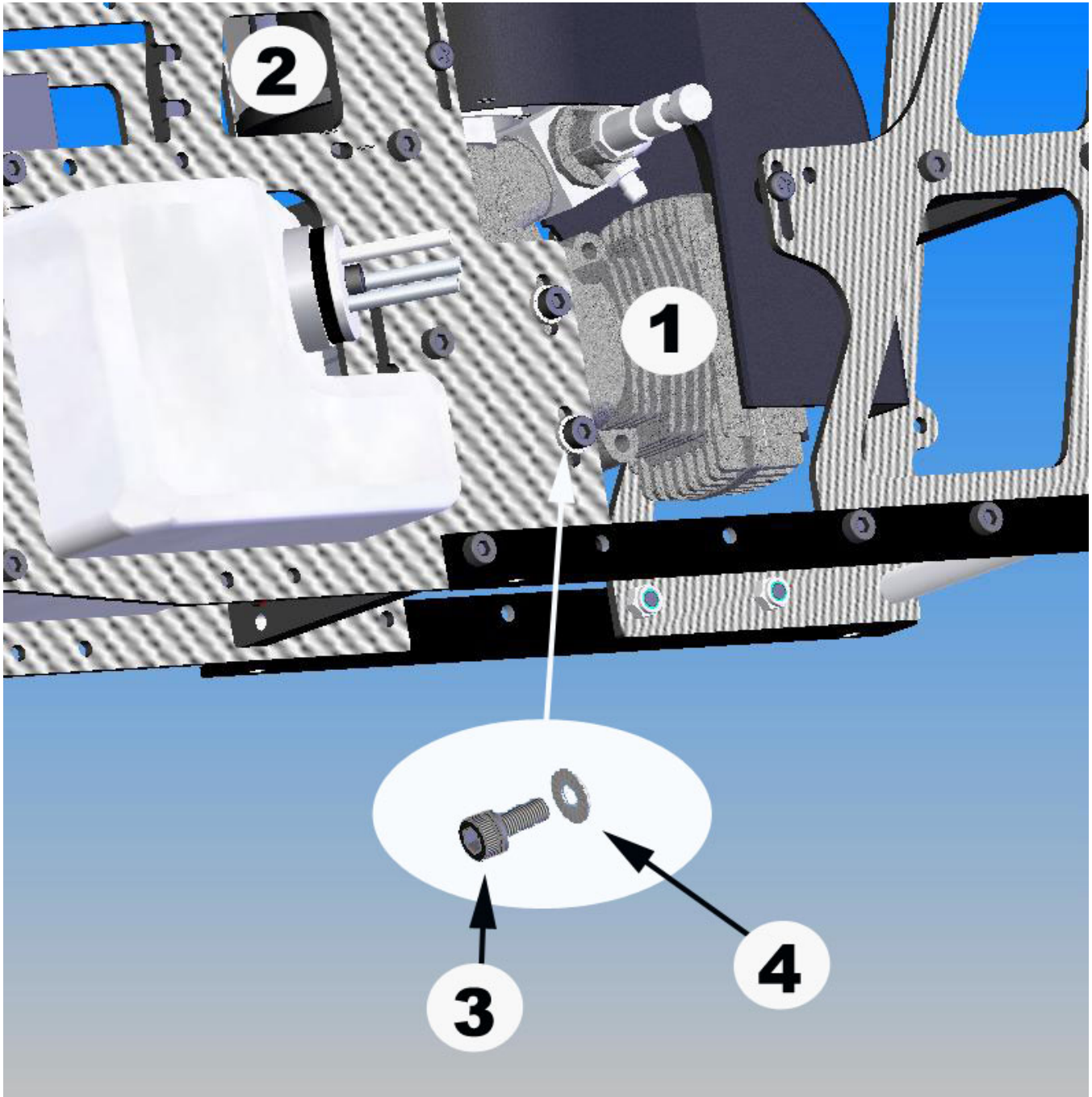

SECTION 3: LANDING GEAR

Bag 3

No.	Bag#	Description	Qty
1	Step 2	Assembly up to Section 2	1
2	3	Landing Gear Strut	2
3	3	Landing Gear Skid	2
4	3	Landing Gear End Cap	4
5	3	M2.5x6 Self Taping Screws	4
6	3	M3x14 Cap Head Bolt	4
7	3	M3 Locknut	4
8****		CA Glue	1

- Drill 4 holes in the Landing Gear Struts with a 3mm drill bit with a spacing of 77mm
- Install the Landing Gear Skids into the Struts.
- Apply CA Glue into the Landing Gear End Cap then insert them into the Skids.
- Drill four 2.5mm holes into the little rounds on the ends of the Struts then secure them with the four M2.5x6 Phillips Screws.

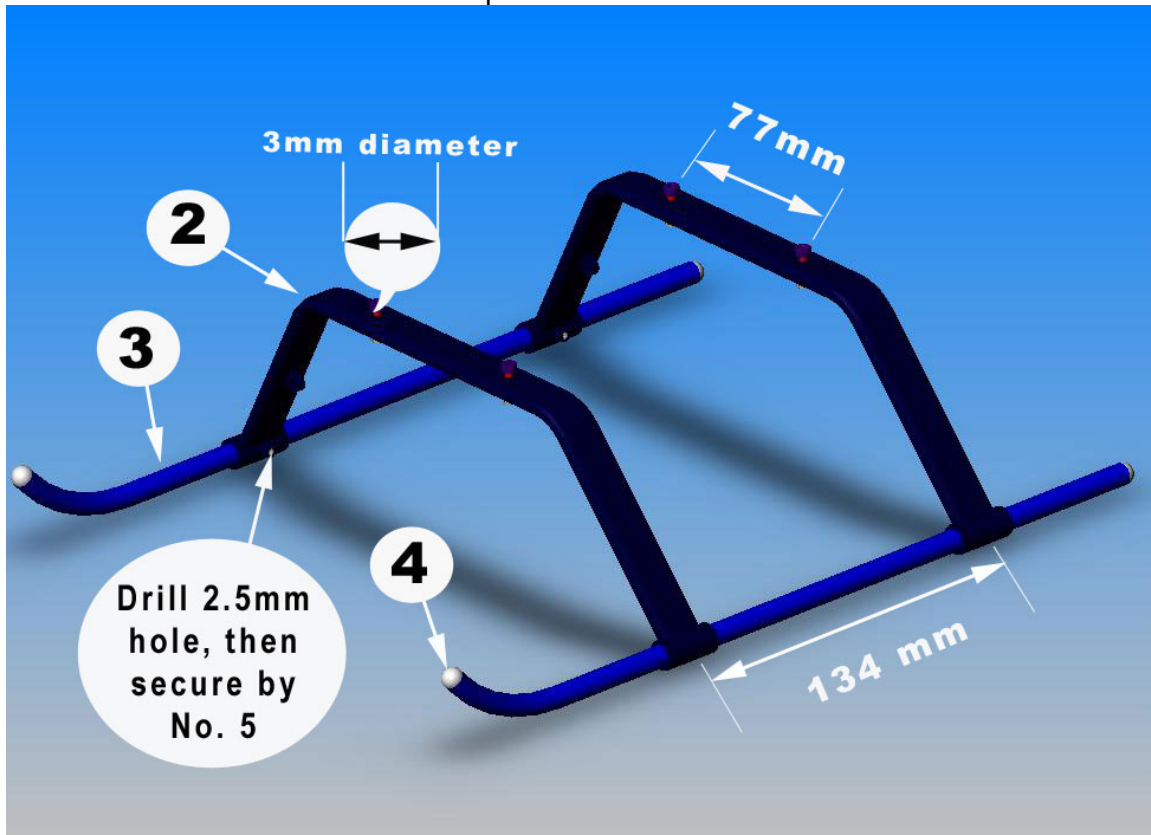

- Install the Main Frames onto the Landing Gear Assembly and secure them with four M3x14 Cap Head Bolts.

Note: It is recommended to use “*Landing Gear Dampener*” to reduce vibration. See “*Other Hardware & Optional Accessories*” to make order. Landing Gear Dampener is installed between the Landing Gear and the Landing Supports.

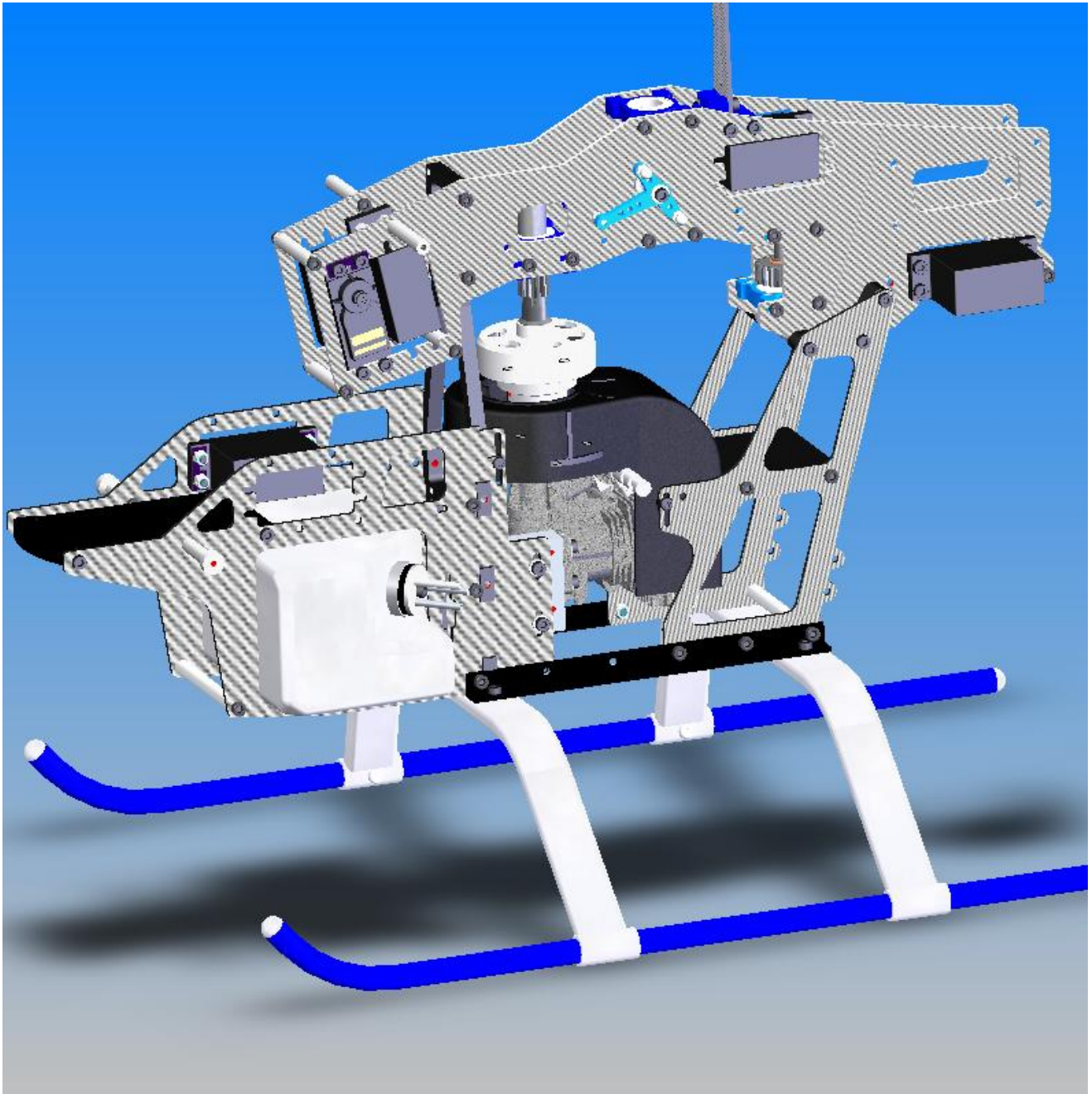

SECTION 4: DRIVING SYSTEM

Bag 4

4-1 MAIN GEAR ASSEMBLY

No.	Bag#	Description	Qty	No.	Bag#	Description	Qty
1	4	Lower Main Gear 88T	1	4	4	Auto-rotation Clutch	1
2	4	Upper Main Gear 97T	1	5	HB	M3x6 Cap Head Bolt	4
3	3	Lower Main Gear Hub	1	6	HB	M3x6 Philip Screw Flat Head	4

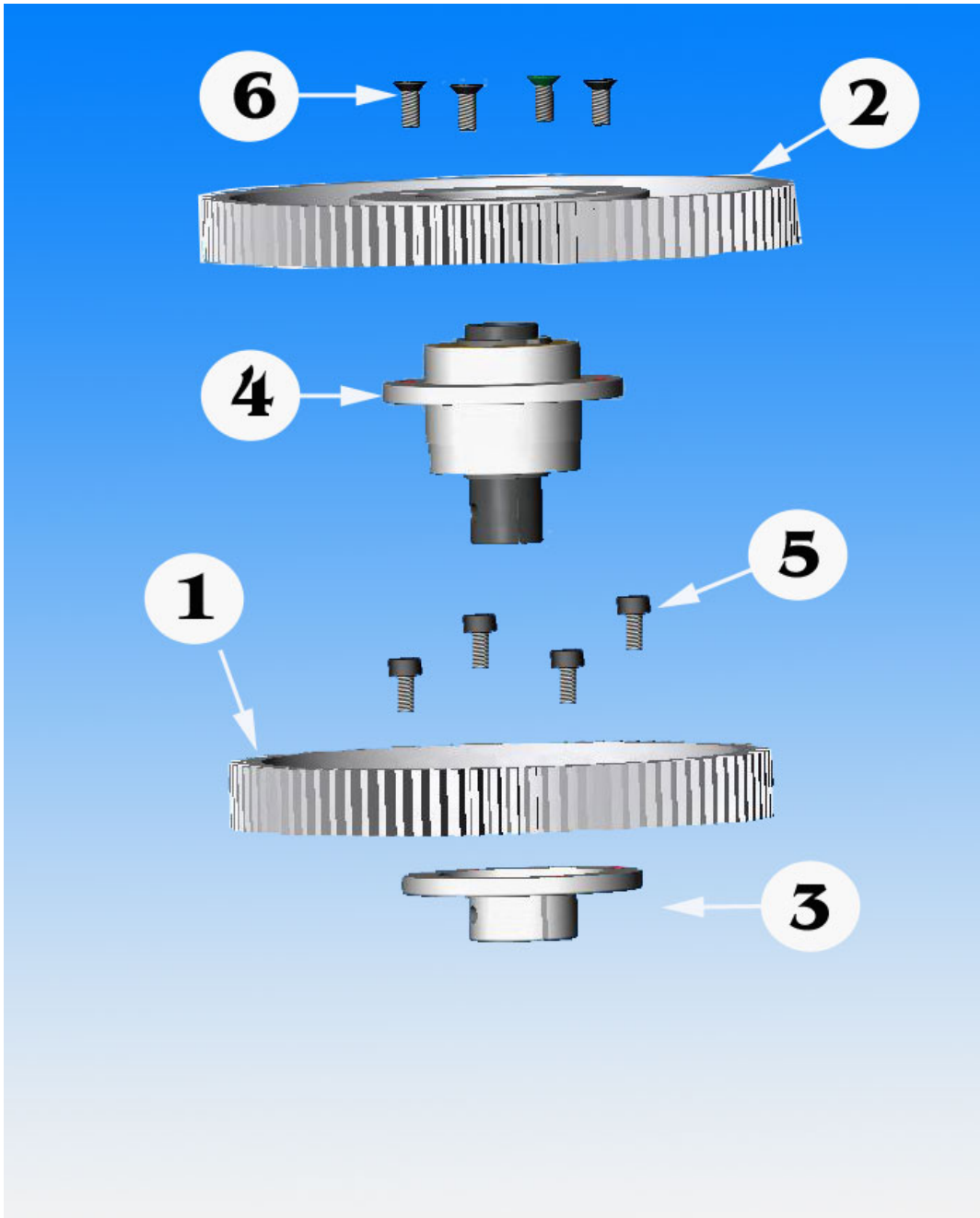

Note: The raised portion of For the Upper Main Gear should be face up.

4-2 MAIN GEAR INSTALLATION

No.	Bag#	Description	Qty	No.	Bag#	Description	Qty
1	Step 4-1	Main Gear Assembly	1	5	HB	M3x22 Cap Head Bolt	1
2	Step 3	Assembly up to step 3	1	6	HB	M3 Locknut	1
3	3	Main Shaft	1	7	HB	M3X5 Set Screw	4
4	3	Main Shaft Collar	1				

- Slide the Main Gear Assembly in; install the Main Shaft down, then secure with one M3x22 Cap Head Bolt and one M3 Locknut.
- Install the Main Shaft Collar on the Main Shaft then secure with four M3x5 Set Screws. Be sure the ridge goes down.

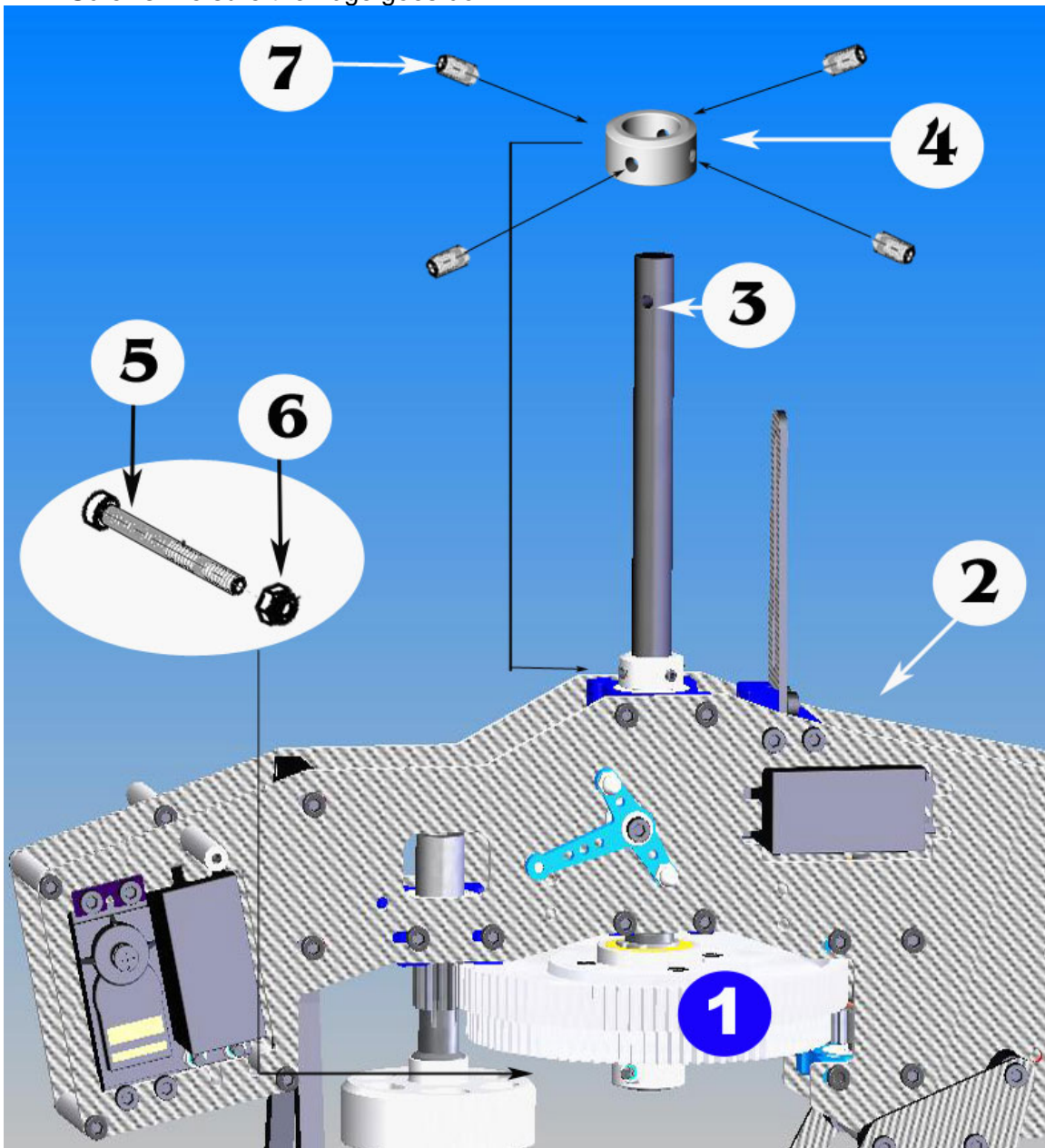

SECTION 5: TAIL ASSEMBLY

Bag 5

5-1 TAIL PULLEY GEAR ASSEMBLY

No.	Bag#	Description	Qty
1	5	Tail Output Shaft	1
2	5	Tail Gear Lock Pin	1
3	5	Tail Pulley Gear	1
4	5	Tail Gear Side Plate	1
5	*****	JP Weld glue	1

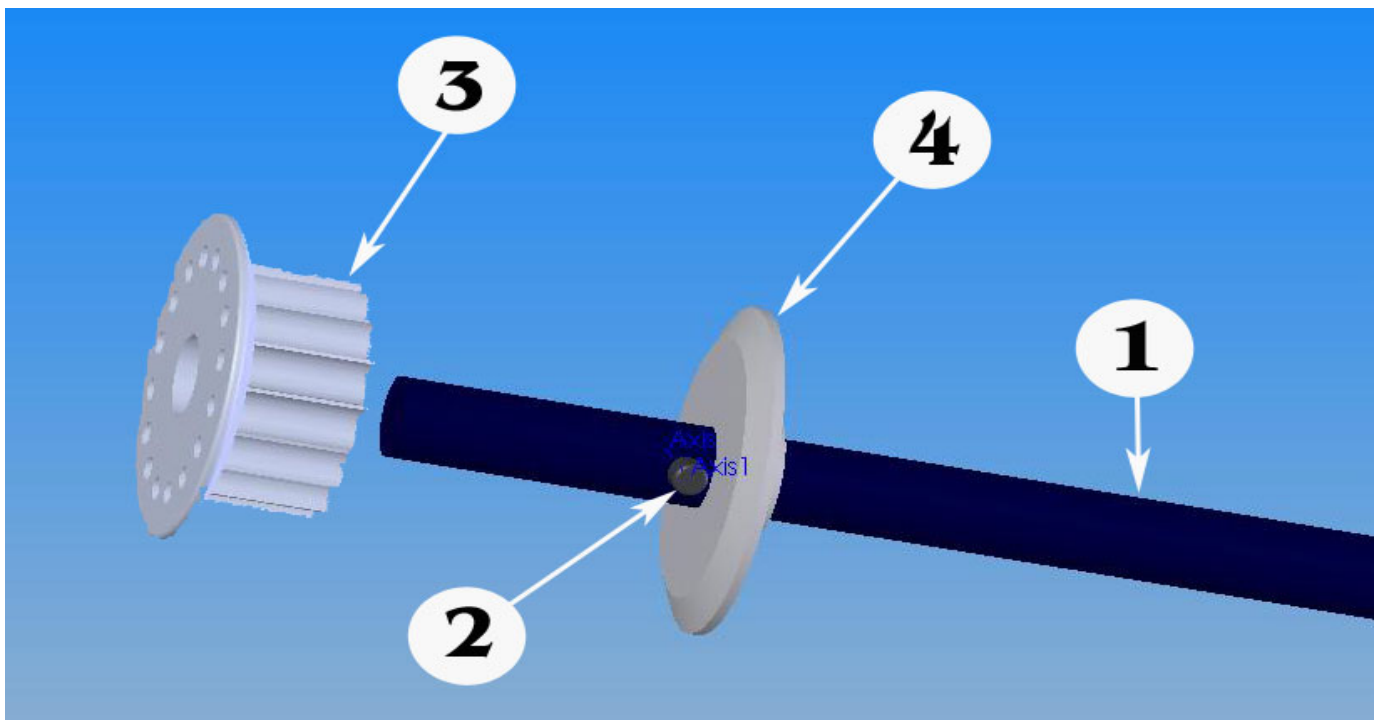

Remember apply JP Weld glue around the pin.

5-2 TAIL ROTOR ASSEMBLY

No	Bag#	Description	Qty	No.	Bag#	Description	Qty
1	Frame	Tail Case Side Plate	2	10	5	M2.3 Medium Ball Link	2
2	5	Tail Pitch Lever Mount	1	11	5	Tail Pitch Slider	1
3	5	5X10X4Flange Bearing	2	12	5	Tail Pitch Control Lever	1
4	HB	M2x6 Phillips Screw	2	13	HB	M3x5x1 Spacer	1
5	In box	Tail Boom (in Box)	1	14	HB	M3x16 Cap Head Bolt	1
6	In box	Timing Belt (in Box)	1	15	HB	M3 Locknut	1
7	HB	M3x6 Cap Head Bolt	6	16	Step 5-1	Tail Pulley Gear Assy	1
8	5	Tail Case Cross Member	1	17	HB	M2.5x6 Cap Head Bolt	1
9	HB	M3x4Pivot Ball Stud	2	18	HB	M3x7 Flat Washer	1

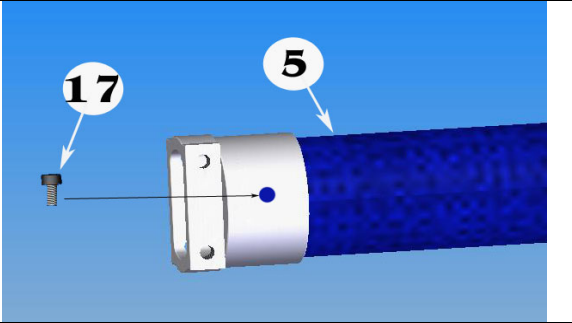
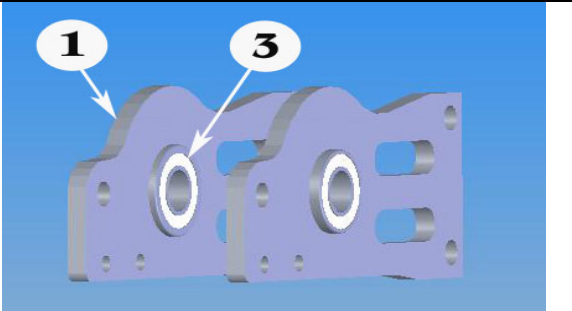
<p>First, to prevent the Boom End from rotating, drill a 2.5mm hole on a side of the Boom End, then secure with an M2.5x6 Cap Head Bolt.</p>	
<p>Install the Bearings into the Tail Case Side Plates. The flanges should be inside. Sometimes, the holes are too tight; you have to sand them a little bit.</p>	

Note: Normally you just need one M3x5x1 Spacer between the Tail Pitch Control Lever and Tail Pitch Lever Mount but you may need two of them in some cases (if you do not have enough clearance for the lever.)

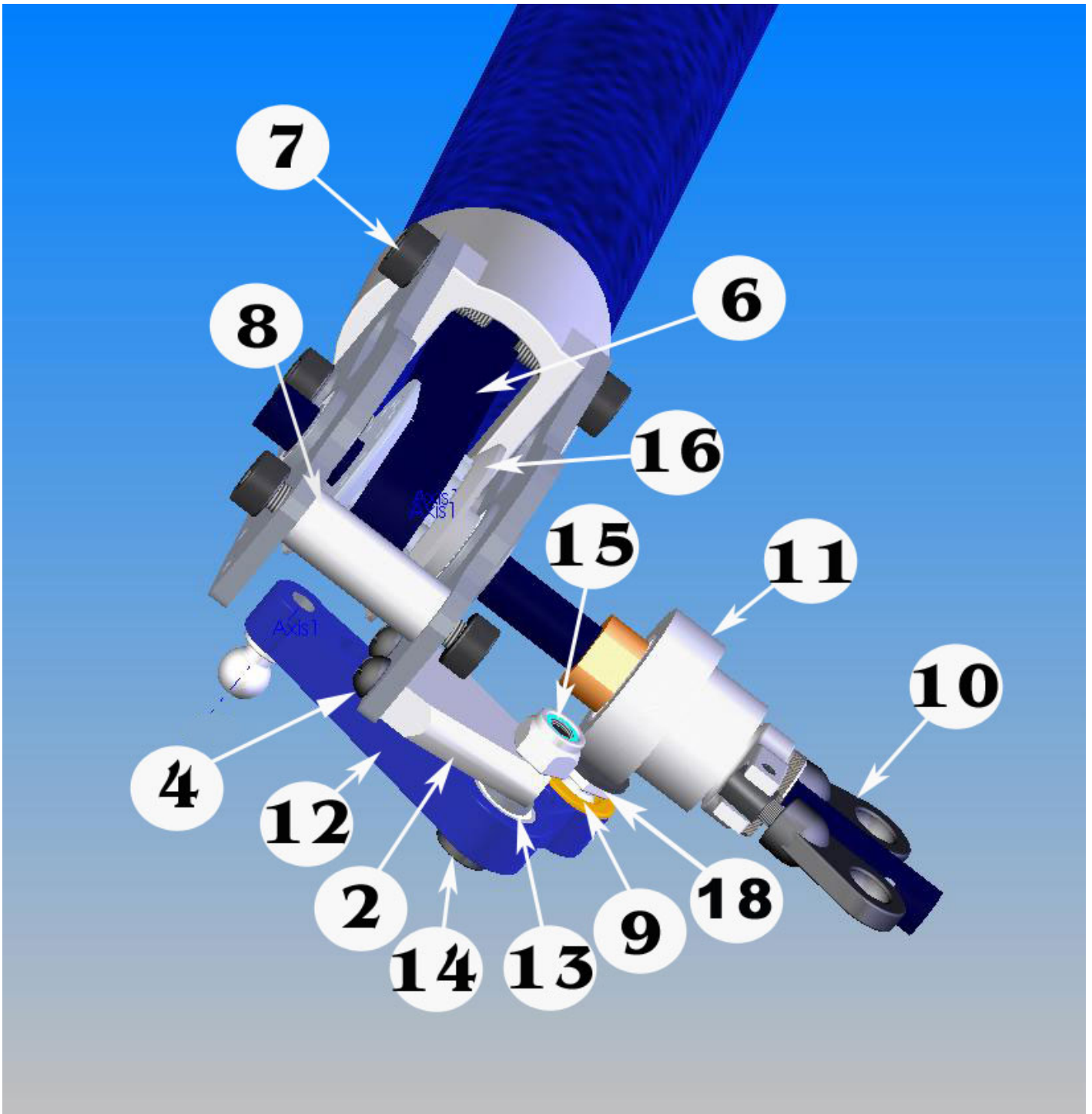

5-3 TAIL ROTOR INSTALLATION

No.	Bag#	Description	Qty	No.	Bag#	Description	Qty
1	5	Dual Bearing Tail Rotor	1	9	5	Horizontal Fin Mount	1
2	HB	M3x22 Cap Head Bolt	2	10	5	Vertical Fin Mount A	1
3	5	Tail Blade	2	11	5	Vertical Fin Mount B	1
4	5	Tail Blade Spacer	4	12	5	Horizontal Fin*	1
5	HB	M2x8 Phillips Screw	2	13	5	Vertical Fin*	1
6	HB	Shim Ball	2	14	HB	M3 Locknut	4
7	HB	M3x6 Cap Head Bolt	2	15	HB	M3x30 Cap Head Bolt	2
8	HB	M3x5 Set Screw	1	16	Step 5-2	Tail Rotor Assembly	1

- Carbon Fin Set is also available for option.

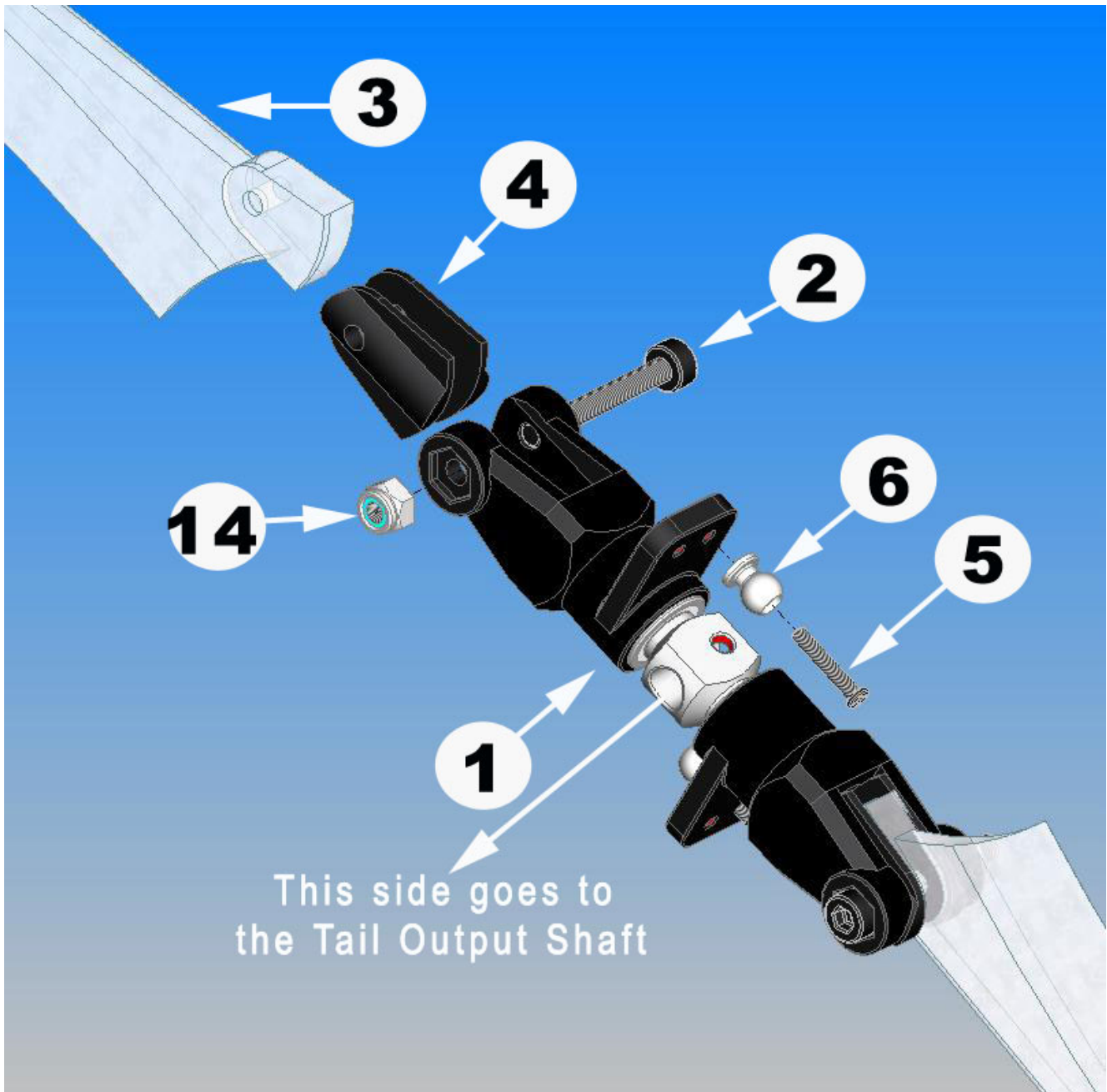

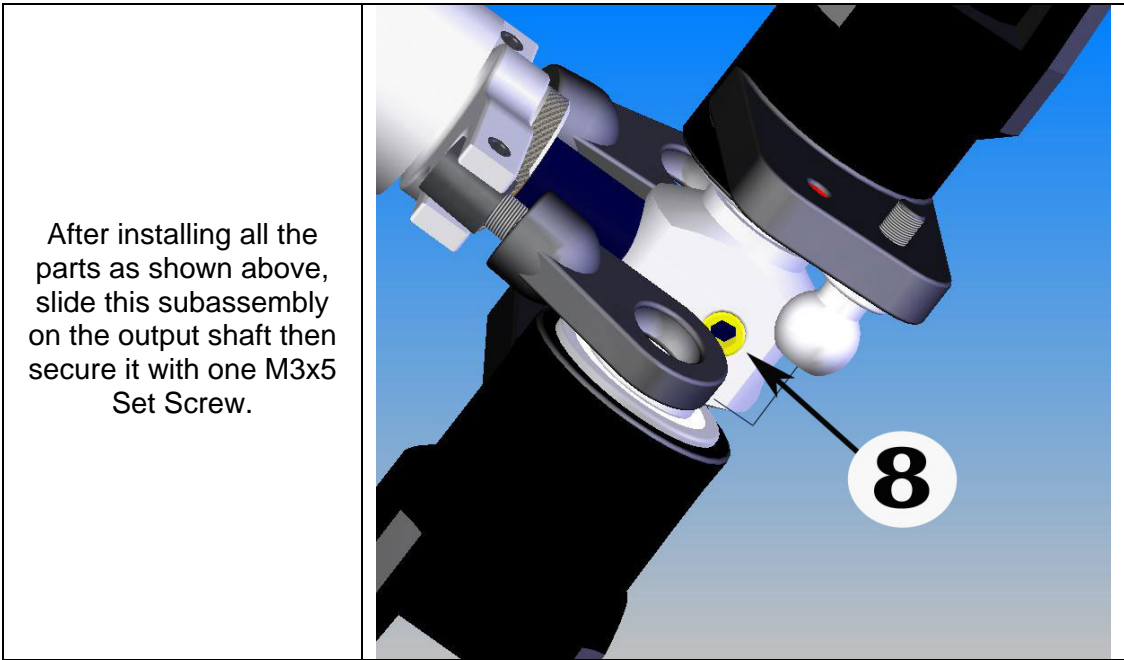

Wrap electric tape around the boom couple times where you are going to install the fin mounts. Note: Fin set may look lightly differently from the one in the kit.

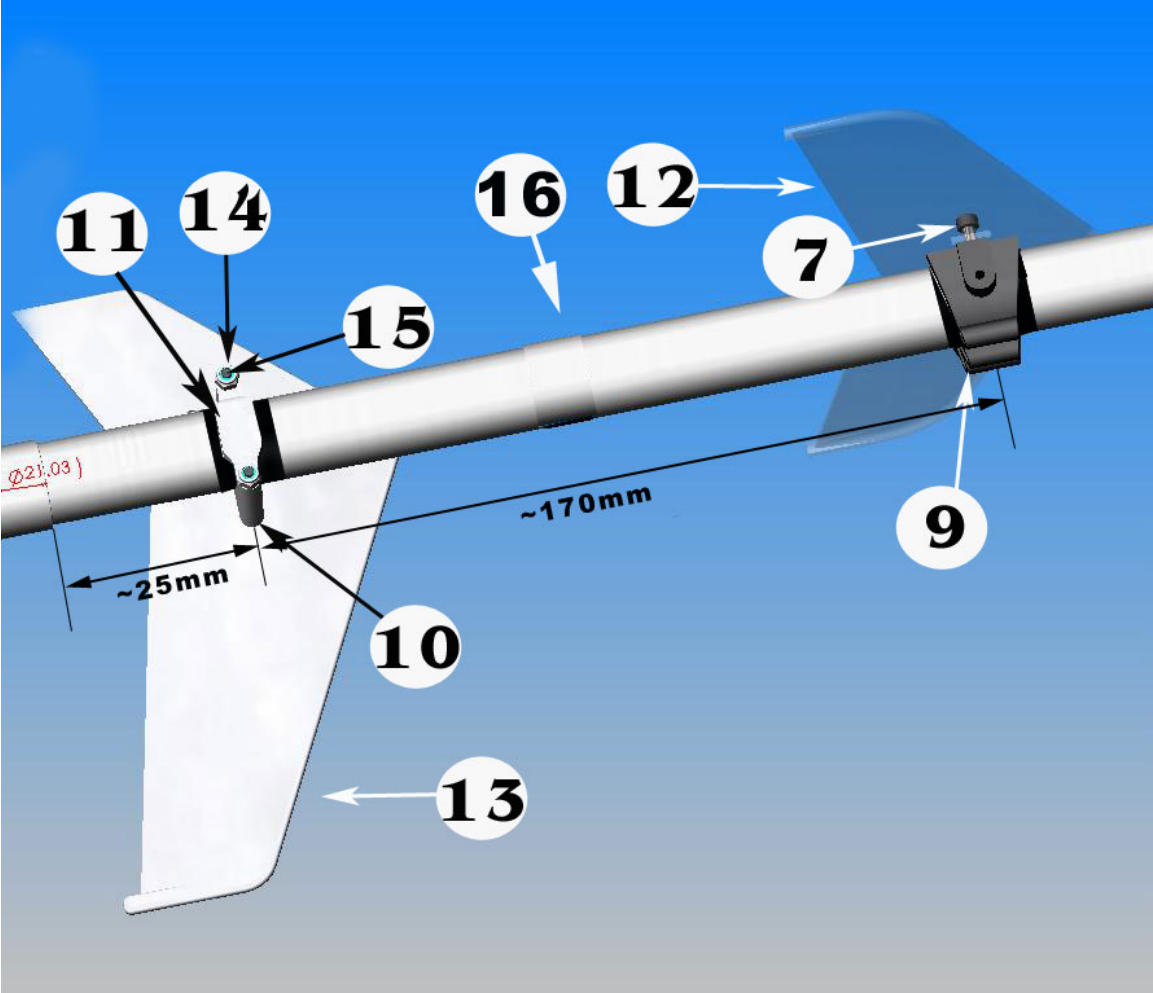

5-4 TAIL INSTALLATION

No.	Bag#	Description	Qt.
1	Step 4	Assembly up to step 4	1
2	Step 5-3	Tail Assembly	1
3	In box	Boom Support	2
4	5	Boom Support End	4
5	HB	M3x12 Cap Head Bolt	2
6	HB	M3x8 Cap Head Bolt	2
7	HB	M3 Locknut	6
8	HB	M3X45 Cap Head Bolt	4
9	5	Boom Holder	2
10****		CA Glue	1

- Note for installing the timing belt: Turn the Tail assembly so that the Tail Output Shaft pointing upward put the belt onto the Transmission, then twist the Tail Assembly 90° to the right. Make sure the belt not too tight or loose. Tighten the four screws on the boom holders.
- Measure the Boom Support carefully before cutting. It is a good idea if you install one end of the rod first, then make the measure then cut it. Remember apply CA Glue for the rods when installing into the Support Ends.

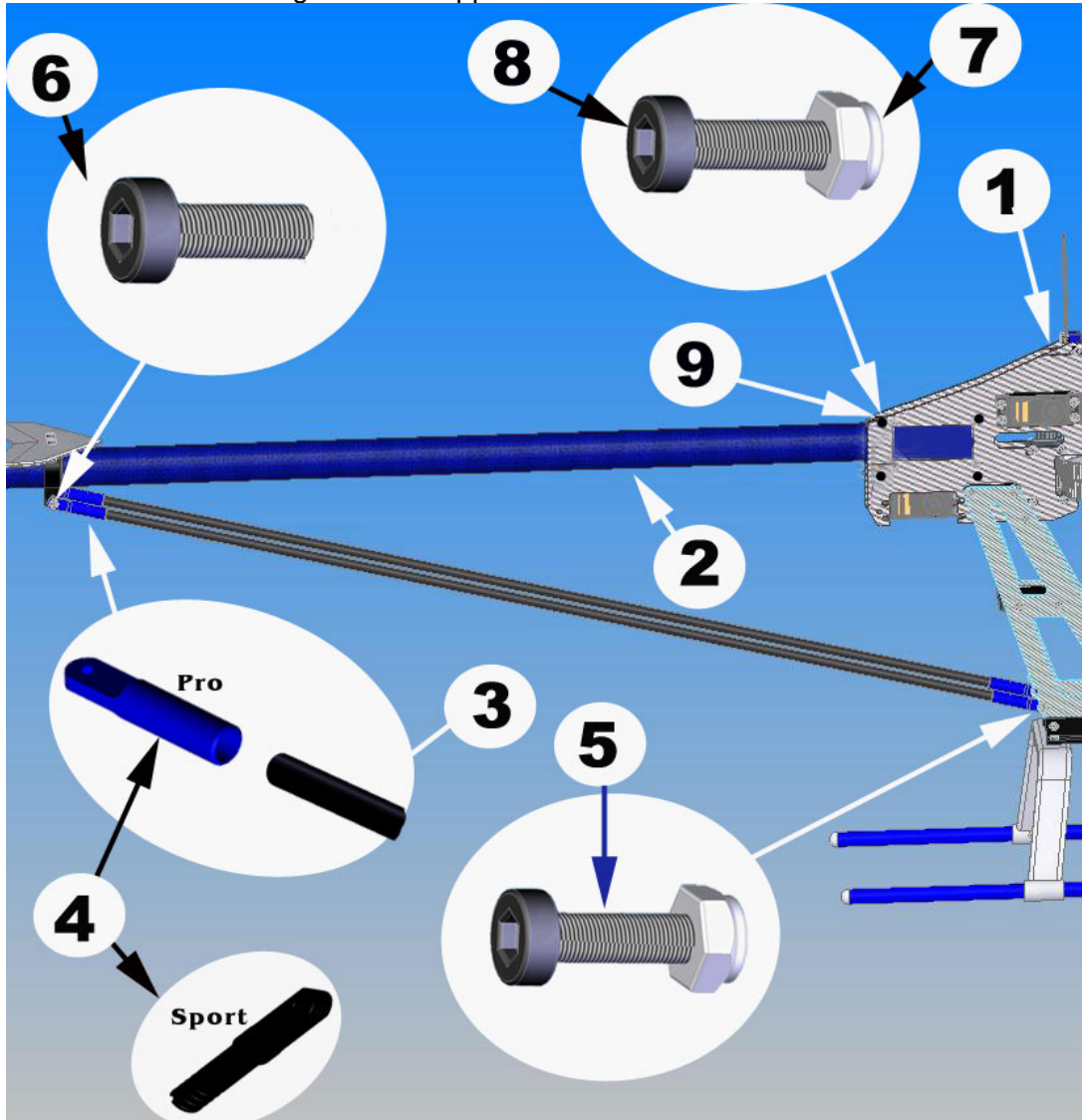

Note: Frames may look differently from the one in ki

6-1 SWASHPLATE ASSEMBLY

No.	Bag#	Description	Qty	Note: There are two kinds of the Swashplate. One has little holes (maybe 7, 4, or 3 of them.) The other has no hole on it. Both work the same. If you got the one with holes, just fill them in with Phillips Screws. If you got the one with no hole, do not worry about Phillips Screws; the Swashplate still works well.
1	6	Swashplate Complete	1	
2	HB	M3x7Pivot Ball Stud	7	
3	HB	M3 x7 Flat Washer	4	
4	HB	M2X4 Phillips Screws	7	

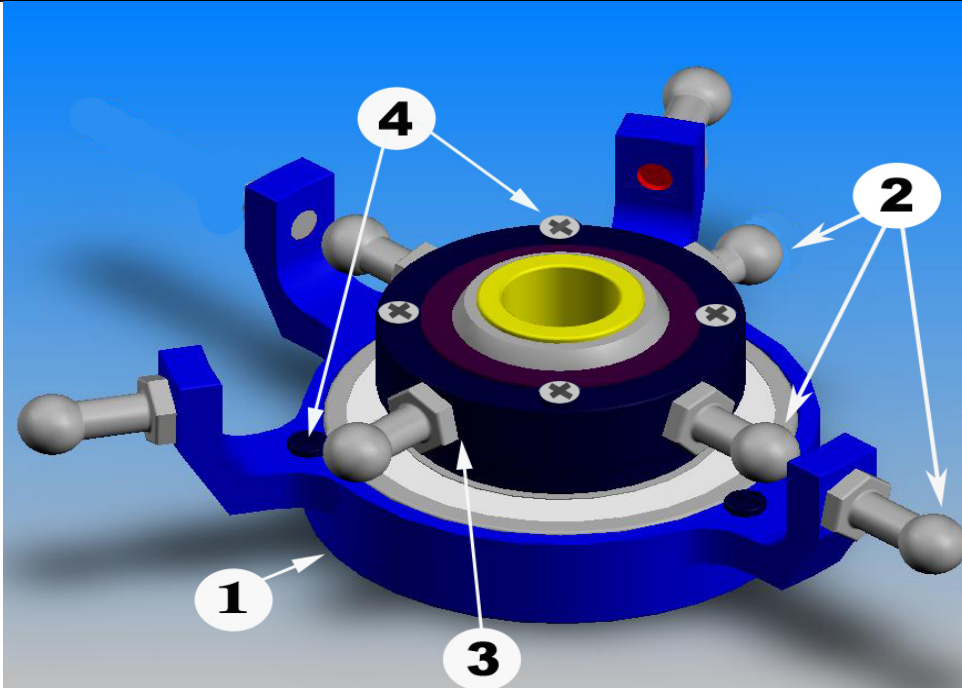

OR

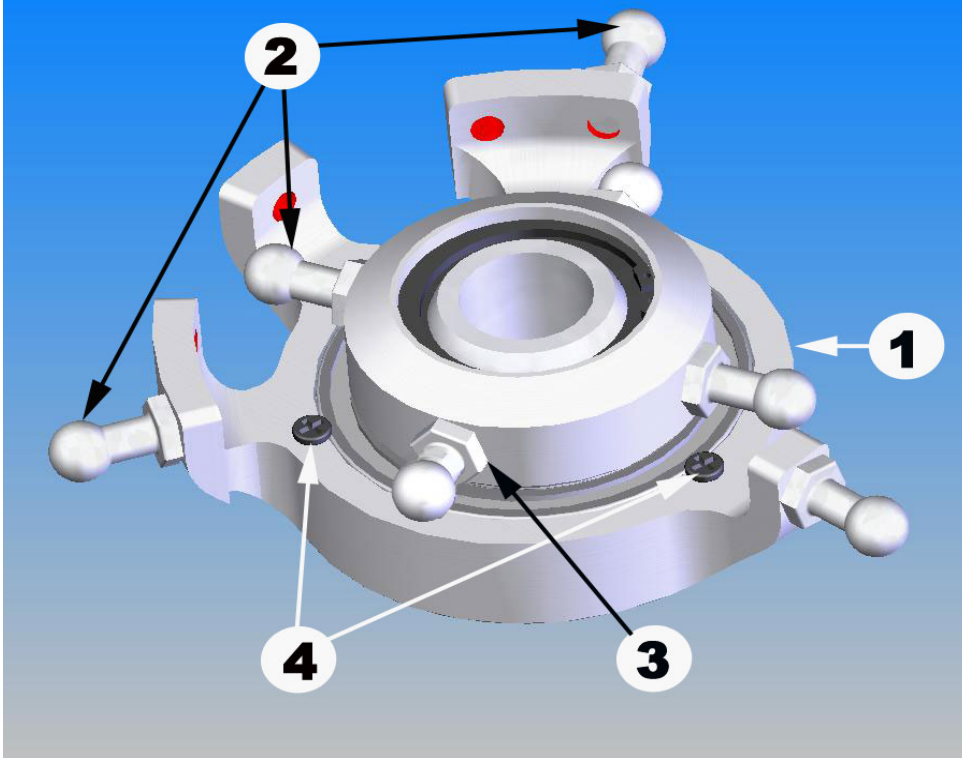

6-2 WASHOUT ASSEMBLY

No.	Bag#	Description	Qty	No.	Bag#	Description	Qty
1	6	Washout Base	1	5	HB	M3x5 Set Screw	2
2	6	Washout Arm	2	6	HB	M3x7Pivot Ball Stud	2
3	6	Washout Link	2	7	HB	M3x12 Cap Head Bolt	2
4	6	Washout Link Pin	2	8	HB	M3X5X1 Spacer	2

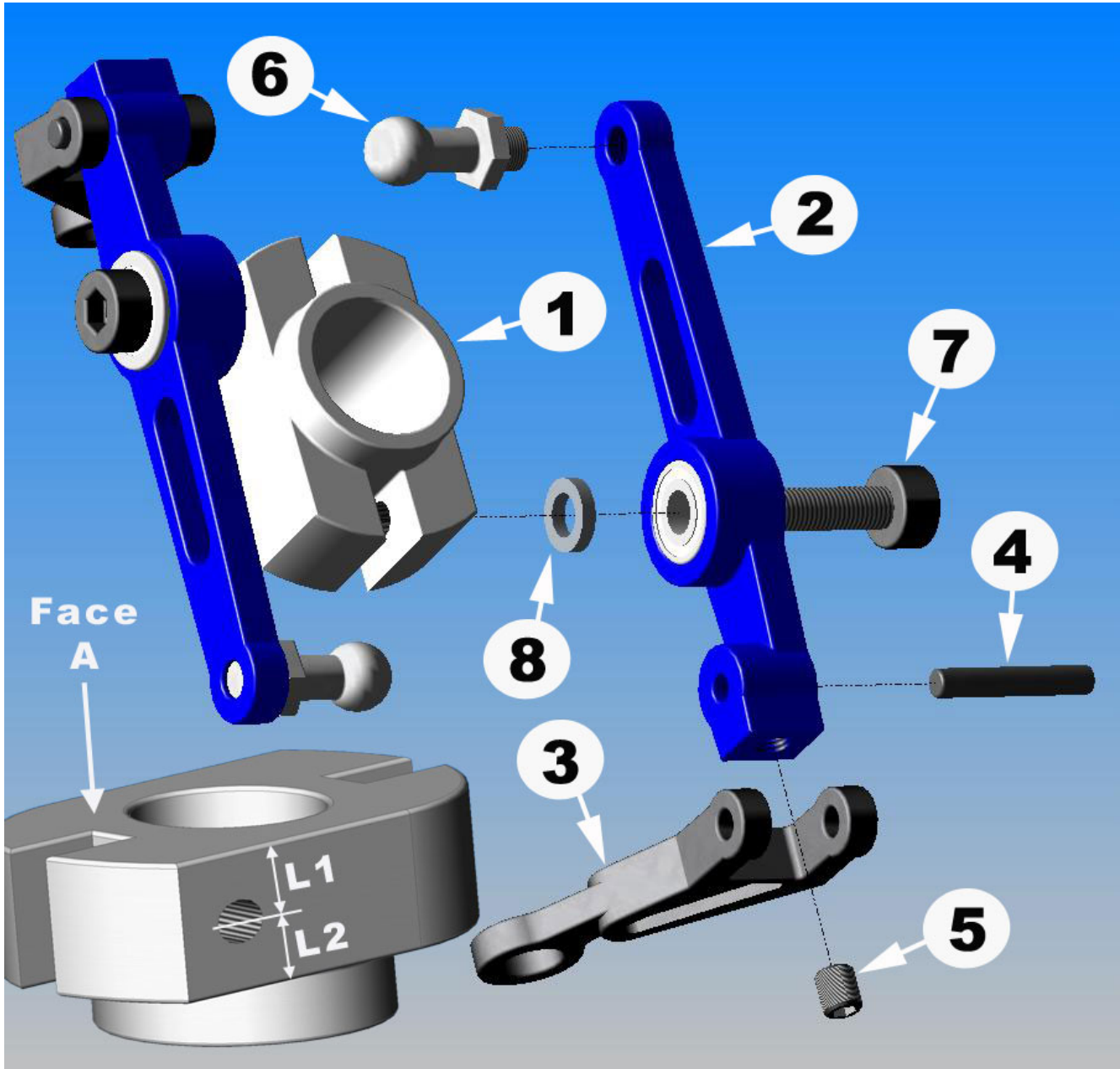

Note: There are some versions of the Washout Base (Item No. 1). All of them work the same but they should be installed appropriately:

- If L1 is shorter or equal to L2, face A should go up.
- If L1 is longer than L2, face A should go down.

6-3 CONTROL SYSTEM INSTALLATION

No.	Bag#	Description	Qty
1	Sep 6-1	Swashplate Assembly	1
2	Step 6-2	Washout Assembly	1
3	Step 5	Assembly up to step 5	1
4	6	Swash Anti-rotation Pin	1

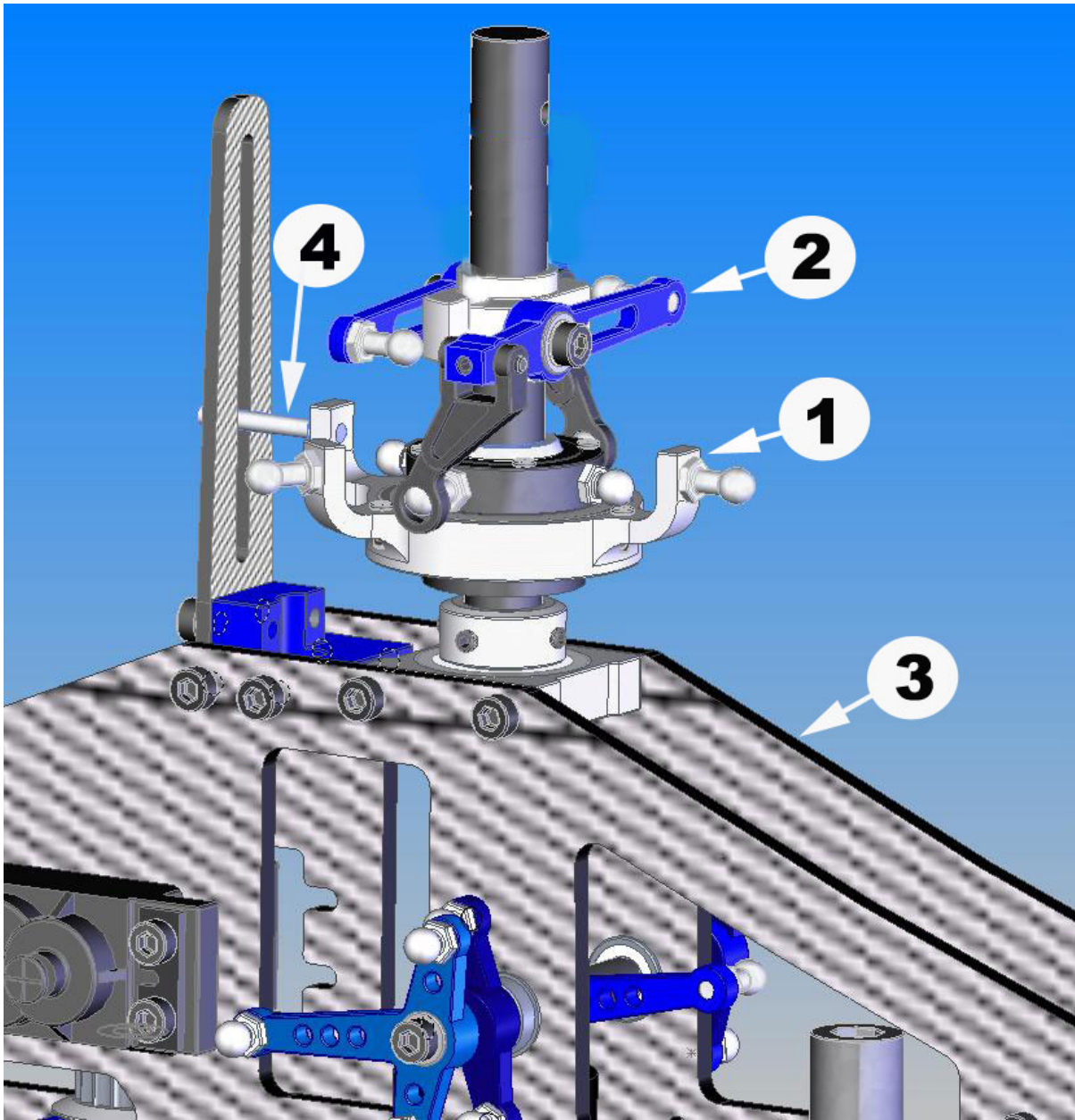

Note: the frame may look differently from the one in the kit.

Connect the Washout Links to the 3x7 Pivot Studs on the Washplate.

7-1 MAIN ROTOR HUB ASSEMBLY

No.	Bag#	Description	Qty	No.	Bag#	Description	Qty
1	7	Main Blade Grip*	2	9	HB	M3X5X3 Spacer	2
2	7	Pitch Arm**	2	10	7	Head Spindle Spacer	2
3	7	Center Hub	1	11	7	Thrust Bearing Spacer	2
4	7	Hiller Arm	2	12	7	8x16x5 Thrust Bearing	2
5	7	Head Spindle	1	13	7	M4 x8 Flange Cap Head Bolt	2
6	7	Dampener O-Ring	4	14	7	8x16x5 Regular Bearing	4
7	HB	M3x7 Pivot Ball Stud(1)	2	15	HB	M3x12 Cap Head Bolt(2)	2
8	HB	M3x10 Cap Head Bolt**	4			*Sport version: plastic	

**Sport version: Pitch Arms is built in the Main Blade Grips so there is no M3x10 Cap Head Bolts (1) or four M3x4 Pivot Ball Stud; (2) or two M3x14 Cap Head Bolt

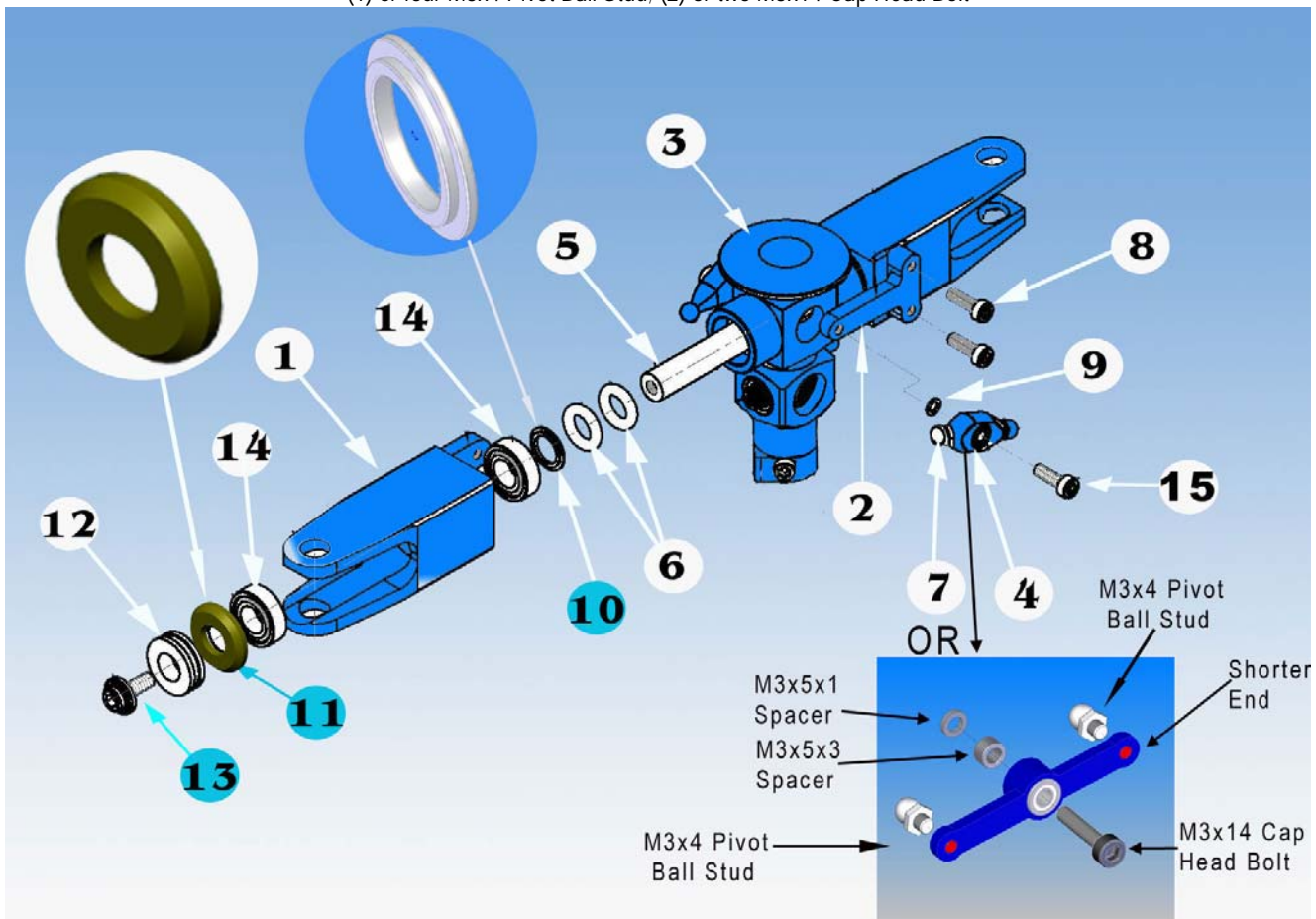

Note: Some Center Hubs are designed for one O-ring each side. If this is your case, use one O-ring each side. The beveled edge of the Thrust Bearing Spacer (No. 11) should be face away from the Center Hub. The flanges of the bearings of the Hiller Arms should face outside. Usually the Thrust Bearing has three parts: two race washers and caged ball bearings. The caged ball bearings will be between two race washers. In some cases, you may get different version of the Thrust Bearing: one race washer, one flat washer, and caged ball bearings in your kit. That is fine; it still works the same. In this case, you need to install the flat washer first (next to Thrust Bearing Spacer-No. 11), then the caged ball bearings, the race washer goes last.

7-2 FLYBAR & SEESAW ASSEMBLY

No.	Bag#	Description	Qty	No.	Bag#	Description	Qty
1	7	Seesaw	1	9	HB	M3x5 Set Screw	2
2	7	Seesaw Collar	2	10	7	4mm Fly-Bar Paddle	2
3	HB	M3x8 Cap Head Bolt	4	11	7	Short Ball End	4
4	HB	M3x7 Pivot Ball Stud	2	12	Step 7-1	Main Rotor Hub	1
5	HB	M4x6x1 Spacer	4	13	HB	M3x7 Flat Washer	2
6	7	Fly-Bar Control Arm A	2	14	7	2.3x10mm Linkage Rod	2
7	7	Fly-Bar Control Arm B	2	15	7	Washout Anti-rotation Pin	2
8	In	4mm Standard Flybar	1	16****		Epoxy Glue/JP Weld	1

Make sure to apply Epoxy Glue/JP Weld to the thread on Flybar when installing the Flybar Paddle.

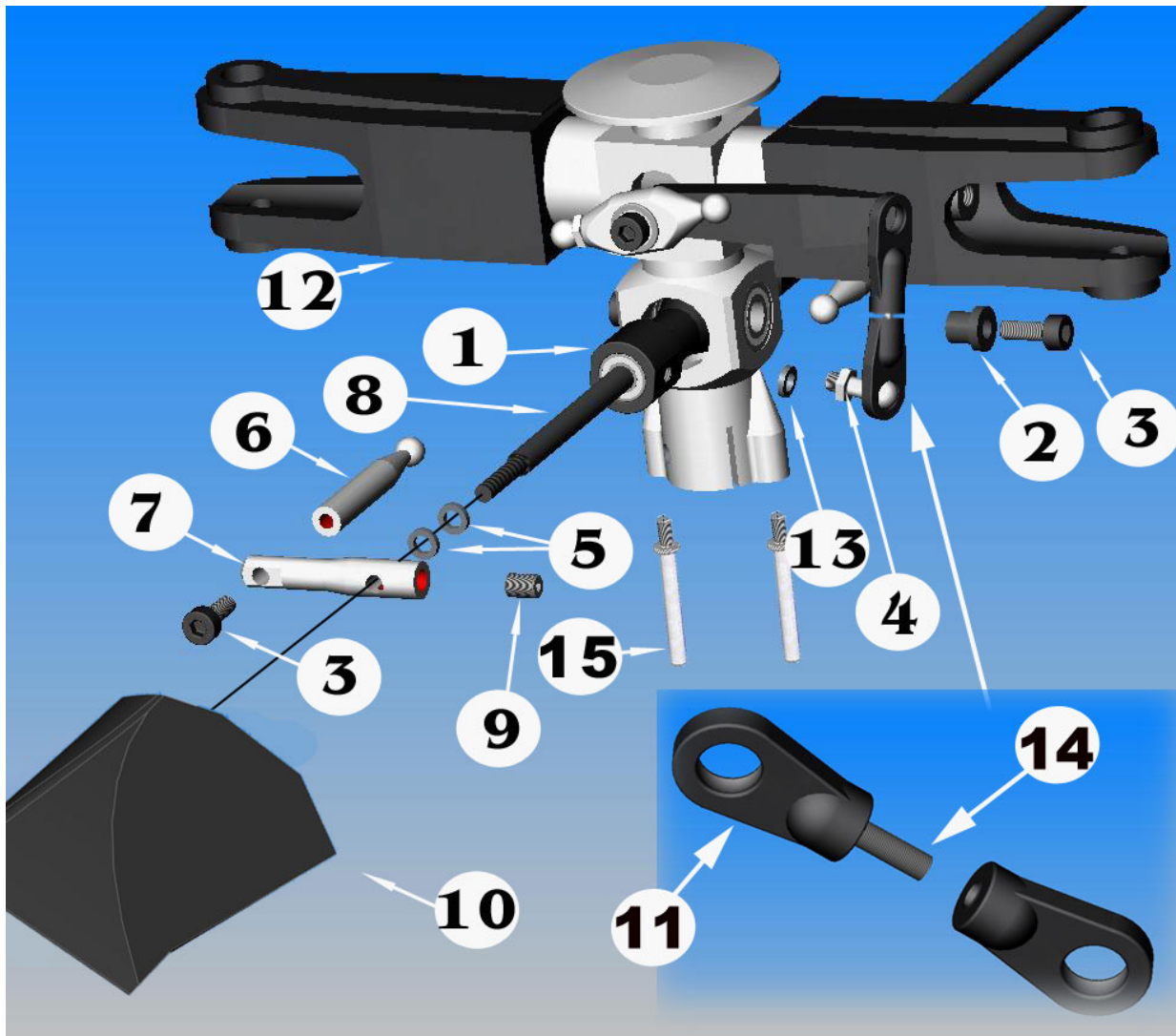

Note: The Center Hub and Flybar Control Arm shown may look differently from the ones in the kit.

7-3 ROTOR HEAD INSTALLATION

No.	Bag#	Description	Qty
1	Step 7-2	Completed Rotor Head (step 7-2)	1
2	Step 6-3	Helicopter (up to step 6-3)	1
3	HB	M3x20 Cap Head Bolt	1
4	HB	M3 Locknut	1

Install the Head Assembly into the Main Shaft, and then secure it by one M3x20 Cap Head Bolt and one M3 Locknut.

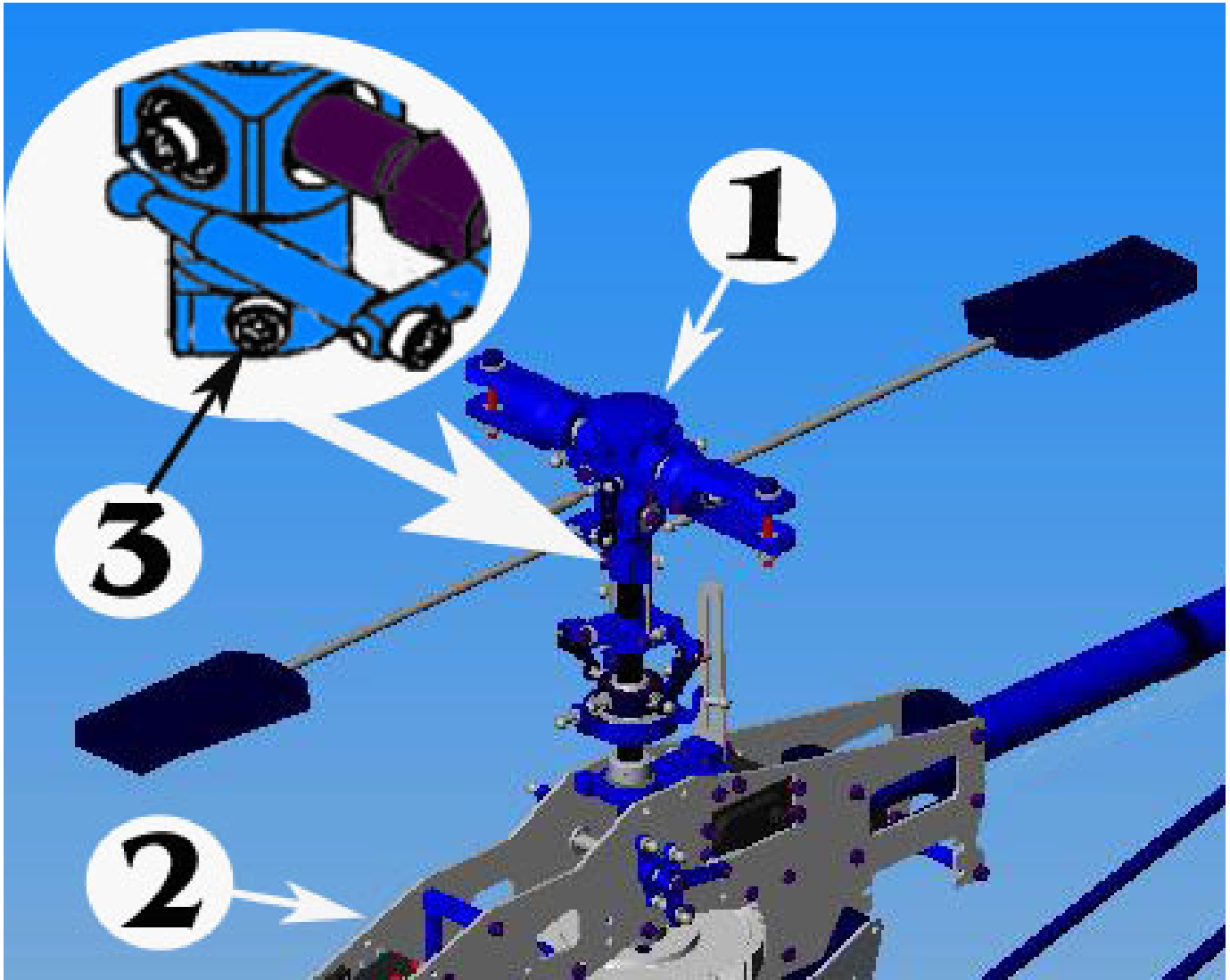

8-1 RUDDER PUSH ROD ASSEMBLY

No.	Bag#	Description	Qty
1	In box	Rudder Push Rod	1
2	8	Rudder Push Rod End	2
3*	8	Pushrod Guide Clamp-on	1
4**	8	Rudder Pushrod Guide	3
5**	8	Rudder Pushrod Guide Insert	3
6	HB	Shim Ball	1
7	HB	M2x8 Phillips Screw	1
8*****		Servo Arm	1
9*****		M3 Servo Phillips Screw	1
10	8	2.3mm Long Ball End	2
11*****		CA Glue	1
12*****		Electric Tape	1

*Sport version does not use this part.
 **Pro version does not use these parts.

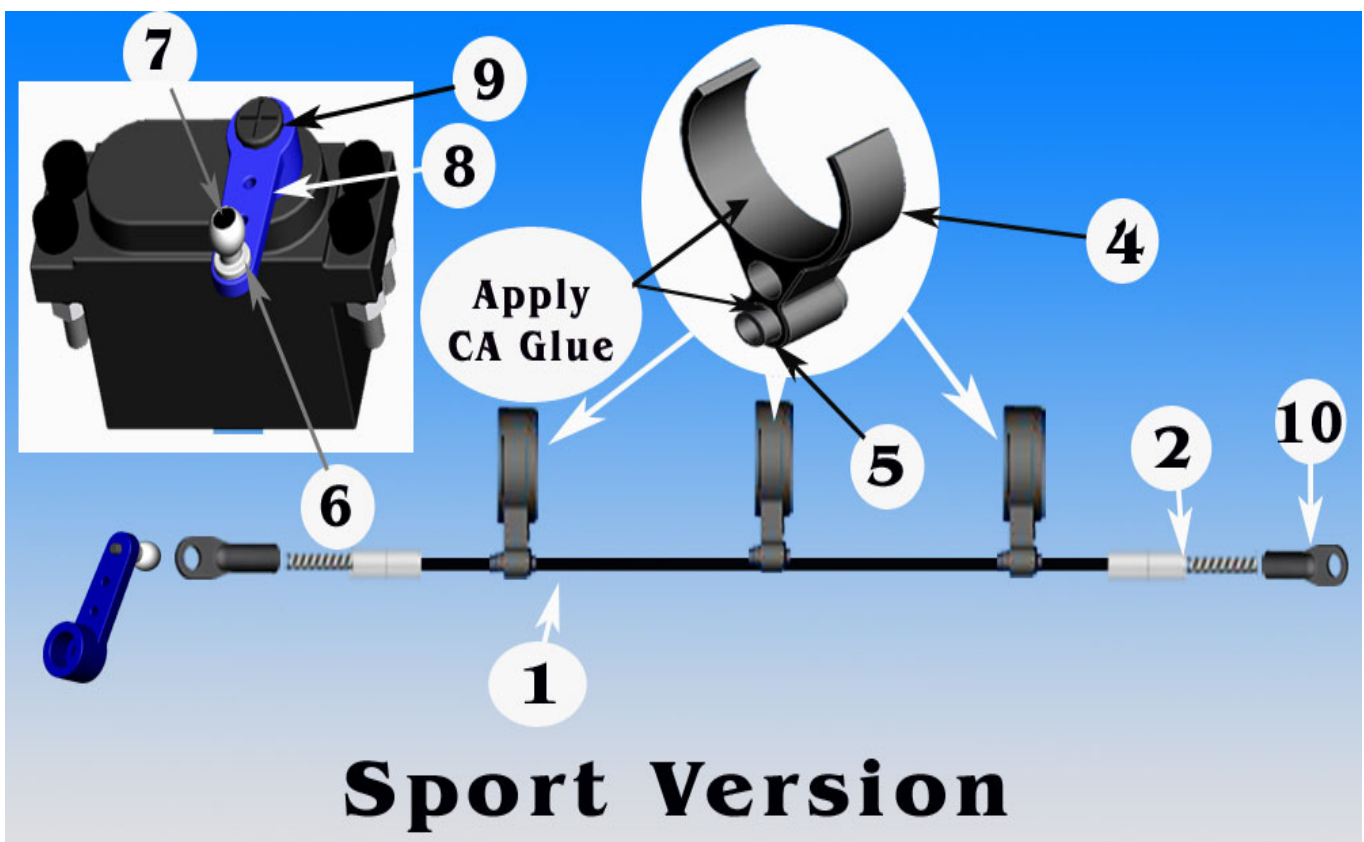

Note: Put electric tape around the Boom before installing the Rudder Push Guide in, so you can remove them later.

For the Pro Version, the diameter of the Pushrod Guide Clamp-on is a little bit bigger than the diameter of the boom. Cut off 5-6 teeth of the clamp and wrap the Boom with a couple of wraps of electrical tape to keep it from slipping.

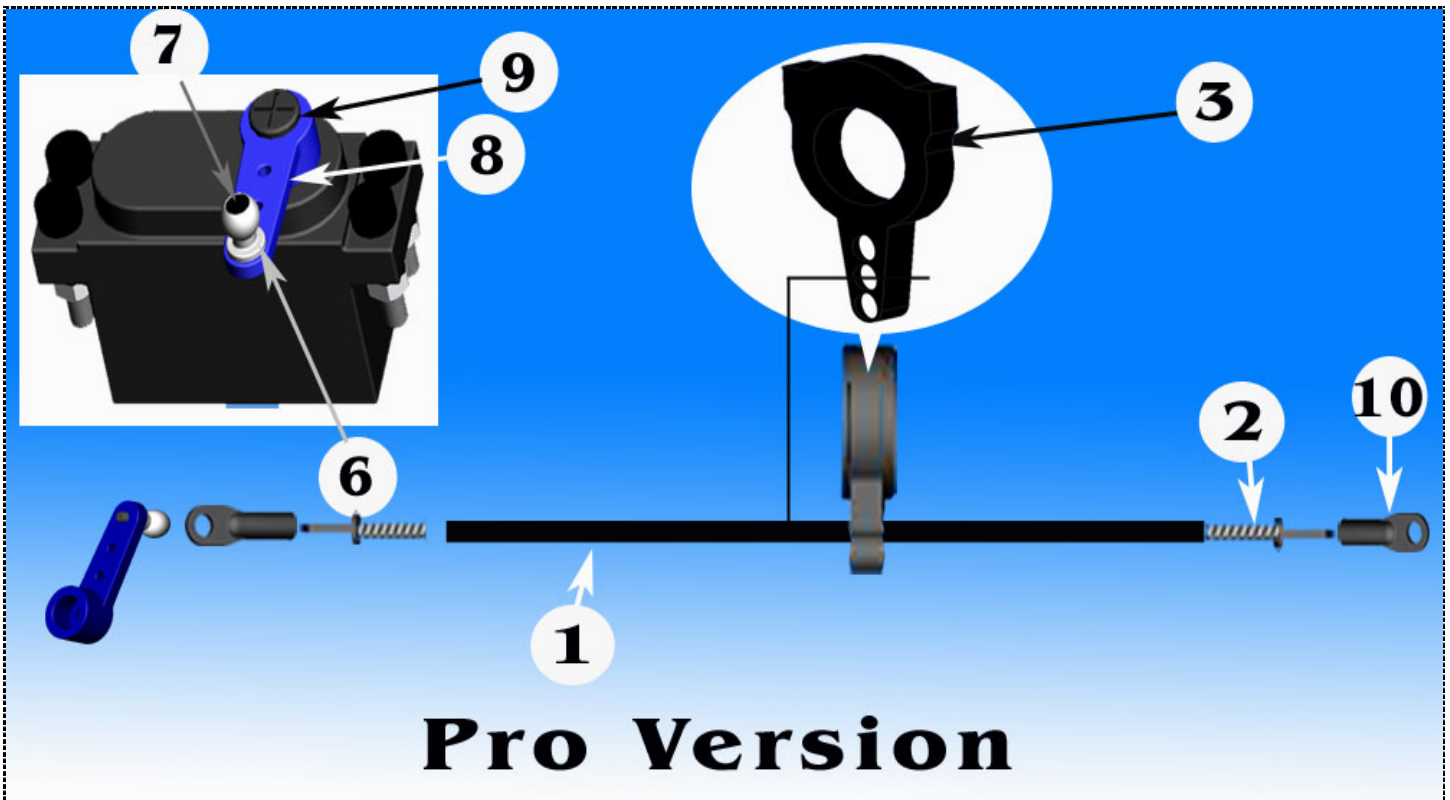
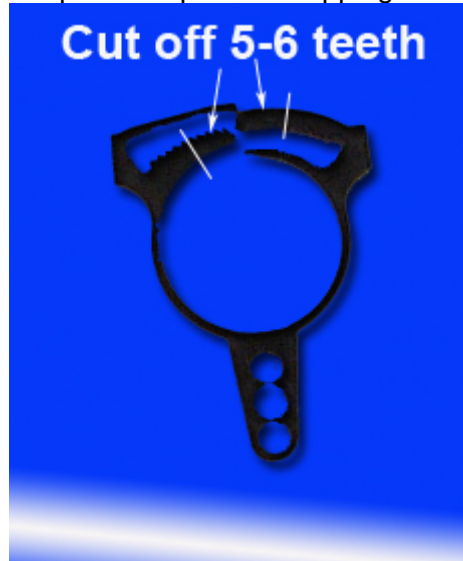

The length of the Rudder Rod measured from center to center should be around 713 mm.

8-2 LINKAGE ASSEMBLY

No.	Bag#	Description	Qty
1	8	2.3 Long Ball End	28
2	8	2.3x25mm Rod	2
3	8	2.3x35mm Rod	3
4	8	2.3x40mm Rod	2
5	8	2.3x65mm Rod	2
6	8	2.3x80mm Rod	2
7	8	2.3x90mm Rod	1
8	8	2.3x100mm Rod	2

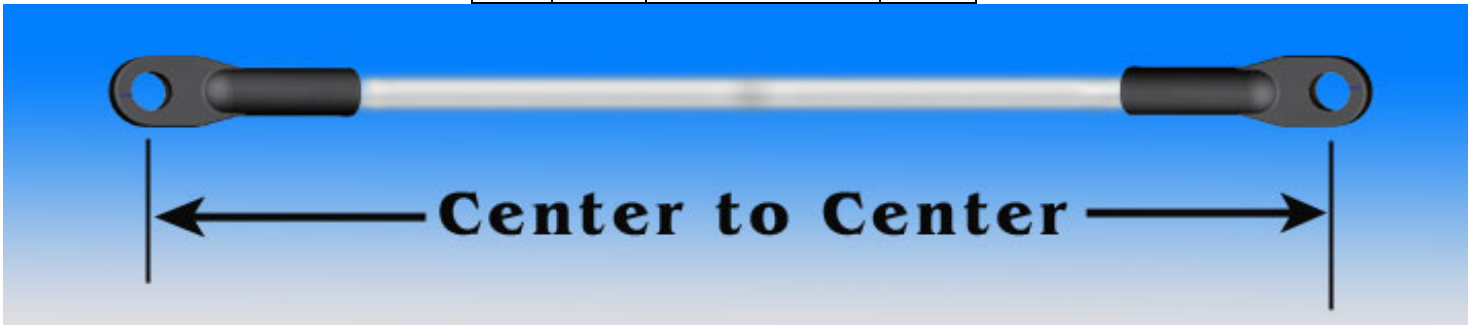

Coding the Rod Assembly:

All the Linkages should be assembled with dimensions measured center to center and coded as following:

No.	Code	Rod Description	Center to Center	Qty
1	A	2.3x25mm Rod	51.5 mm	2
2	B	2.3x35mm Rod	64 mm	3
3	C	2.3x40mm Rod	66.5 mm	2
4	D	2.3x65mm Rod	94.5 mm	2
5	E	2.3x80mm Rod	110 mm	2
6	F	2.3x90mm Rod	124mm	1
7	G	2.3x100mm Rod	133 mm	2

Note: Look close to a ball end; you will see one side is different from the other. One has a round marked on it. The other is just plain. When installing a ball link into a pivot ball stud (or a shim ball) the side with a round should face away from a ball stud (or shim ball.)

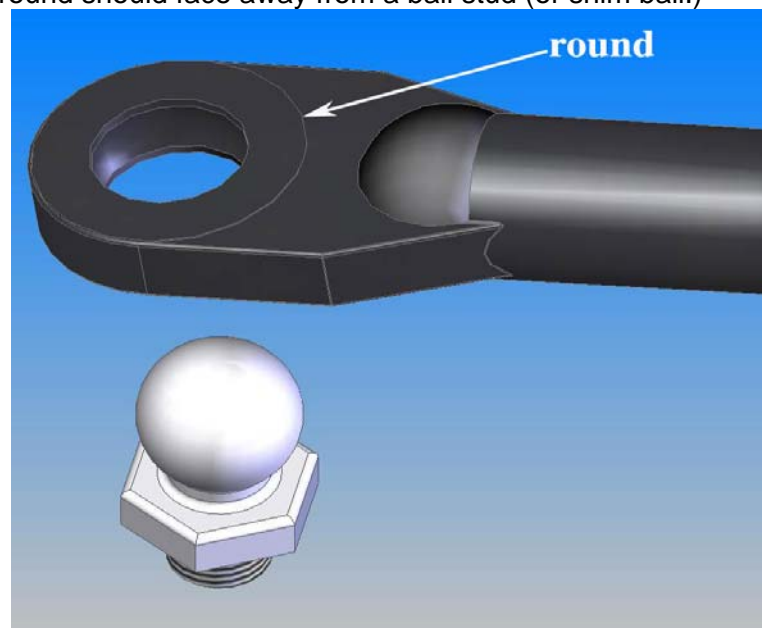

8-3 LINKAGE INSTALLATION

No.	Code	Center to Center	Qty	No.	Bag#	Description	Qty
1	A	51.5 mm	2	8	8-1	Helicopter (up to step 7)	1
2	B	64 mm	3	9****		Double Servo Arm	3
3	C	66.5 mm	2	10	HB	Shim Ball	8
4	D	94.5 mm	2	11	HB	M2x8 Phillips Screw	8
5	E	110 mm	2	12****		M3 Servo Phillips Screw	4
6	F	124mm	1	13****		Throttle Extension	1
7	G	133mm Rod	2	14****		M2.5x10 Cap Head Bolt	1
				15****		Single Servo Arm	1

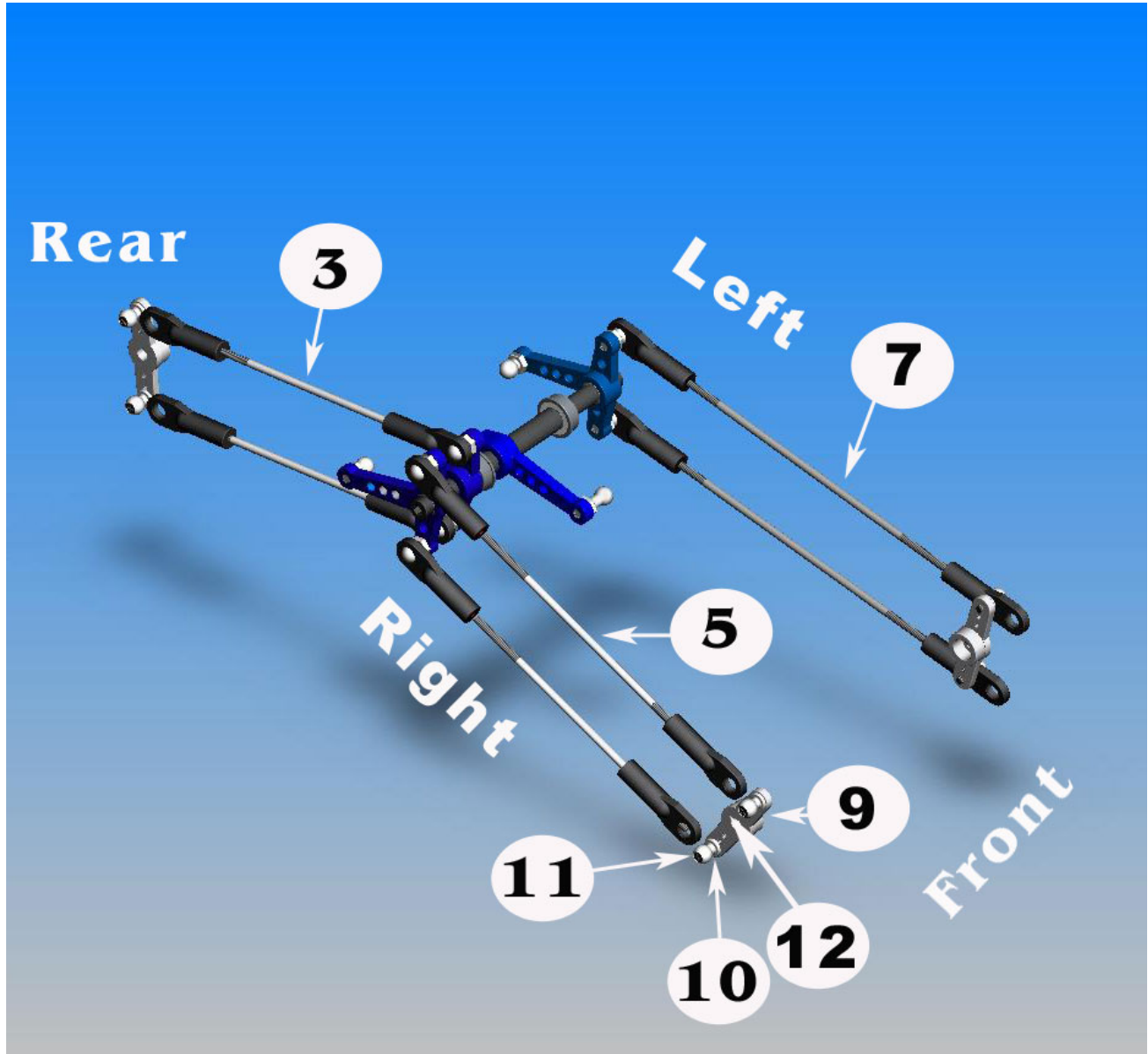

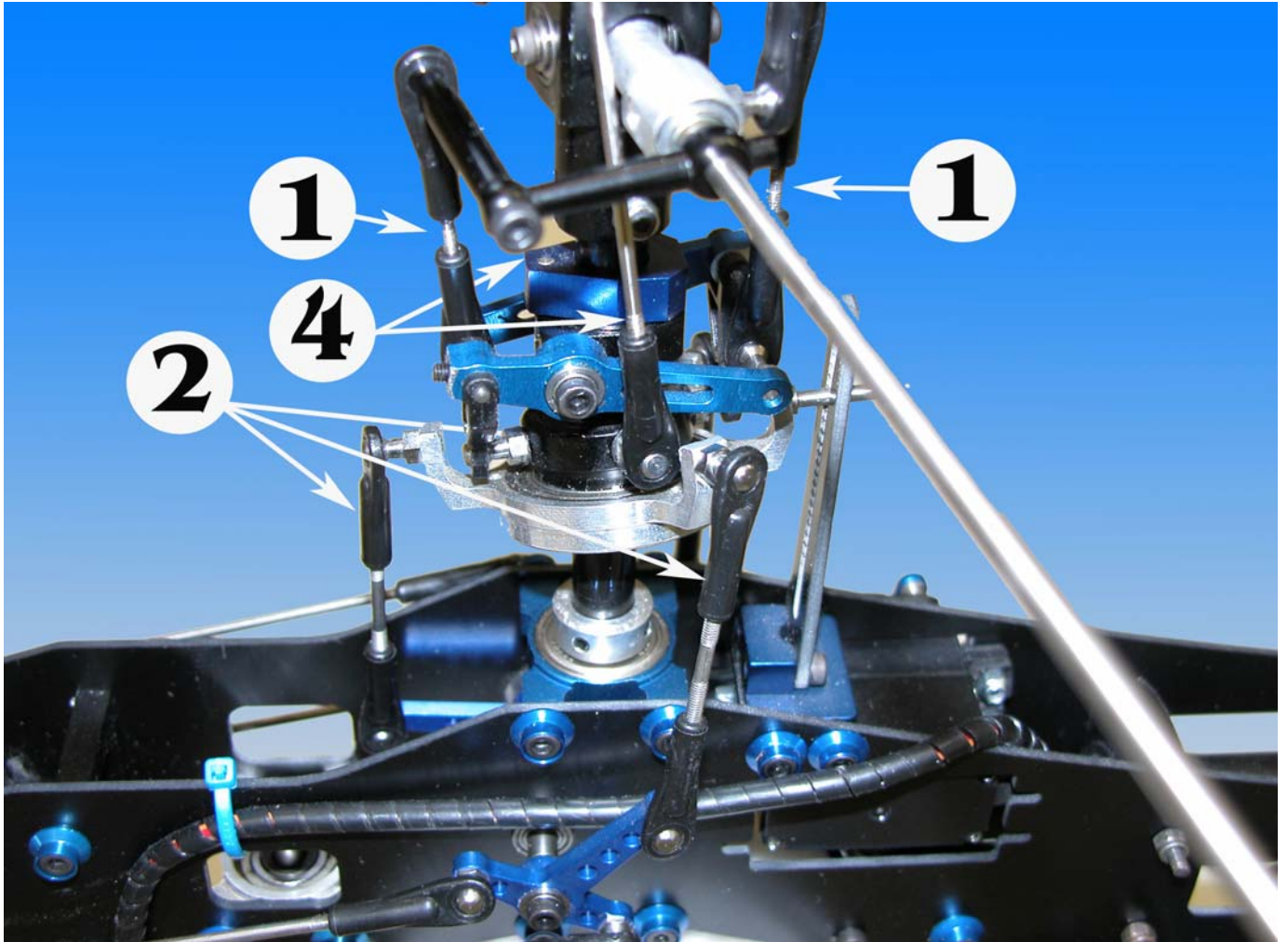

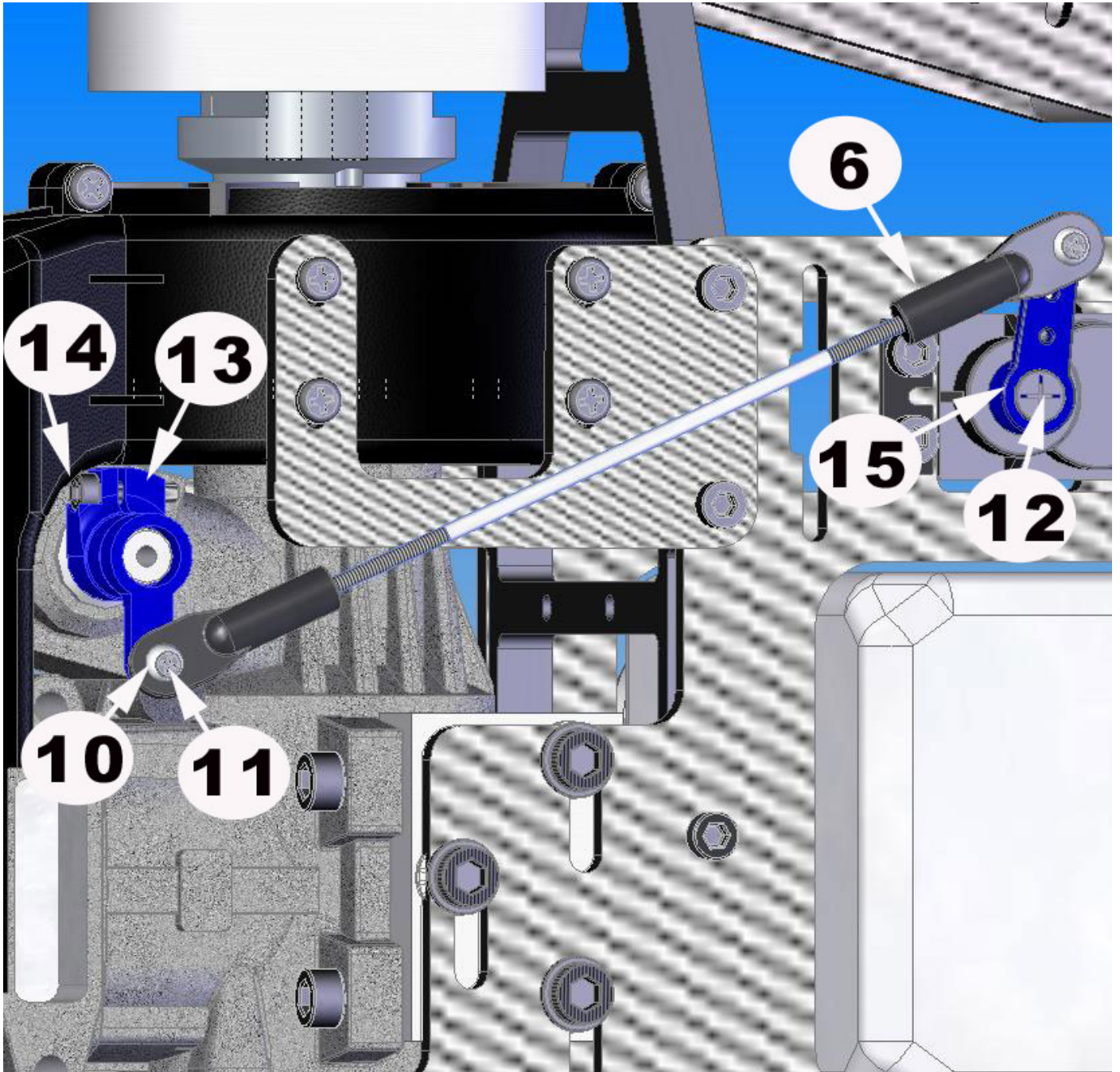

Note: the frame may look differently from the one in the kit.

8-4 MUFFLER & HOSES ASSEMBLY

No.	Bag#	Description	
1****		Muffler	1
2****		M3x35 Cap Head Bolt	2
3****		Hose	3
4****		M3 Locknut	2

Note: For some kinds of engines and mufflers, you may have to cut the frame angle to make room for screws to fit. Although the drawings do not show the valves for hoses, you need to put one somewhere between the fuel tank and the engine; the other for refueling hose. The frame may look differently from the one in the kit.

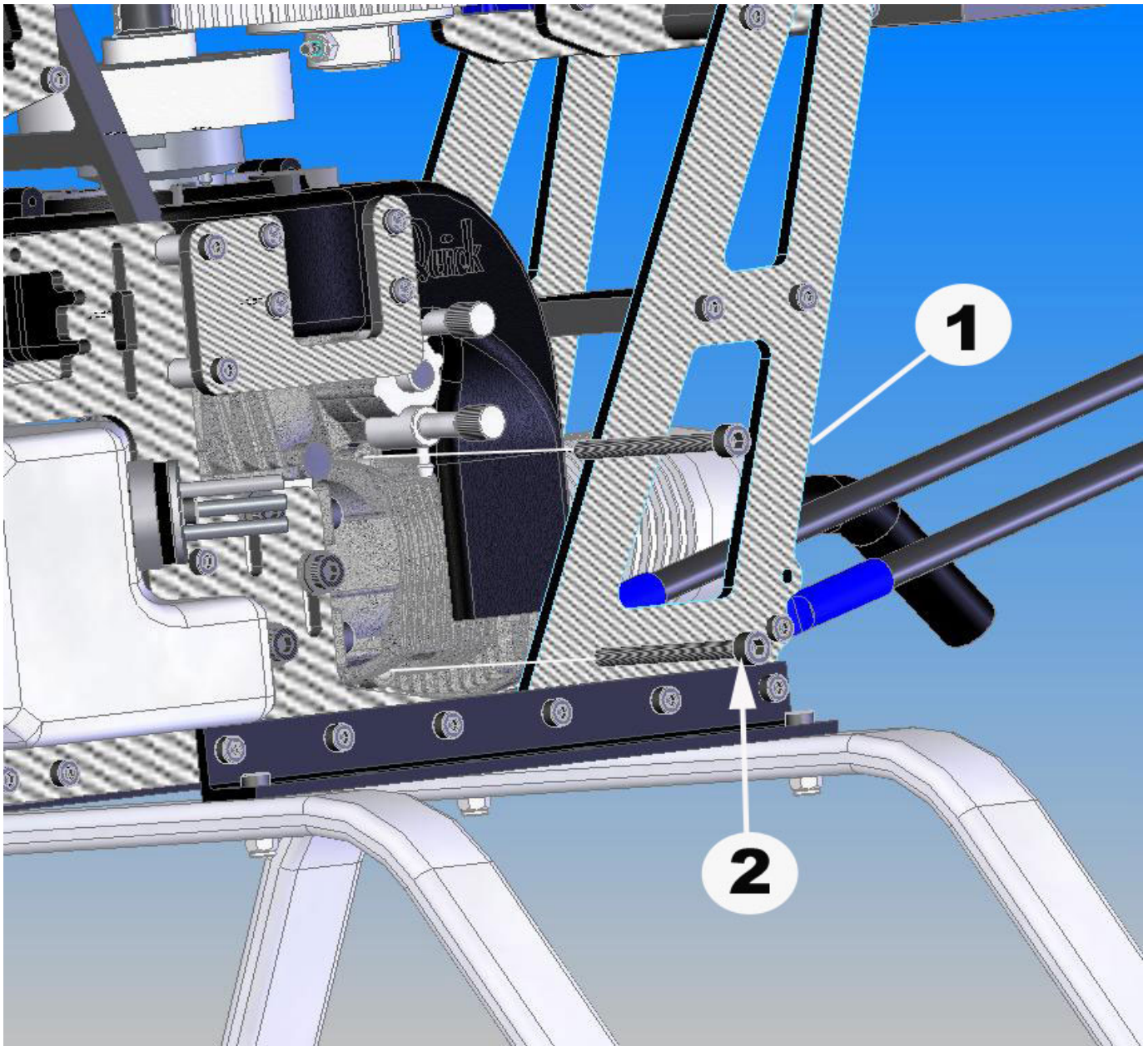

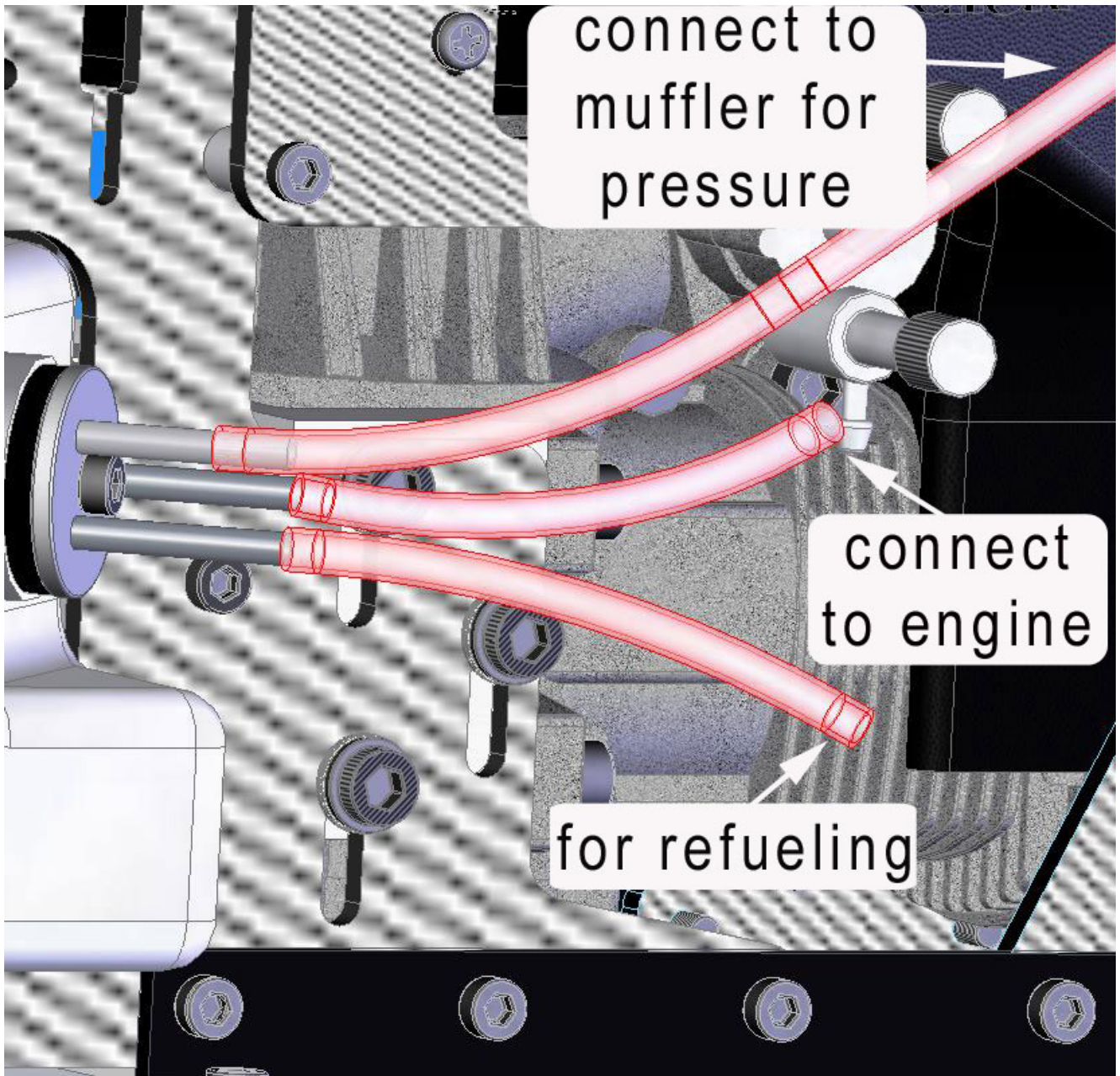

8-5 MAIN BLADE INSTALLTION

No.	Bag#	Description	Qty
1	Step 8-4	Helicopter (up to step 8-4)	1
2****		Main Blade	2
3****		Main Blade Spacer	4
4	8	M4x30 Cap Head Bolt	2
5	8	M4 Locknut	2

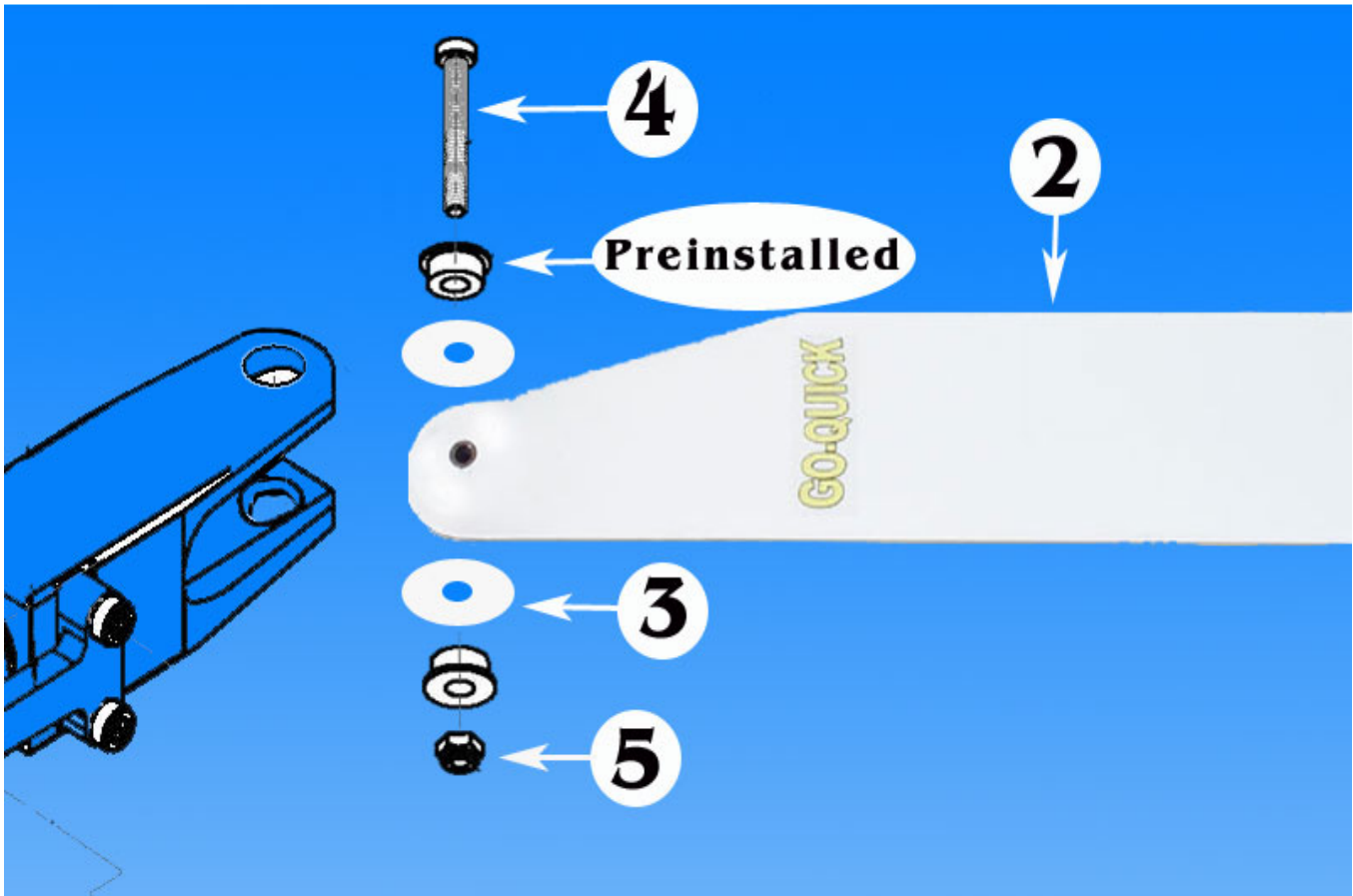

8-6 RADIO SETUP

No.	Bag#	Description	Qty
1	Step 8-5	Helicopter (up to step 8-5)	1
2	****	Radio	1
3	****	Receiver	1
4	****	Gyro	1
5	****	Battery for Receiver	1

Before setting up the radio, you have to install the receiver, gyro, and batteries for your helicopter. See your radio, receiver, and gyro manuals for how to hook up.

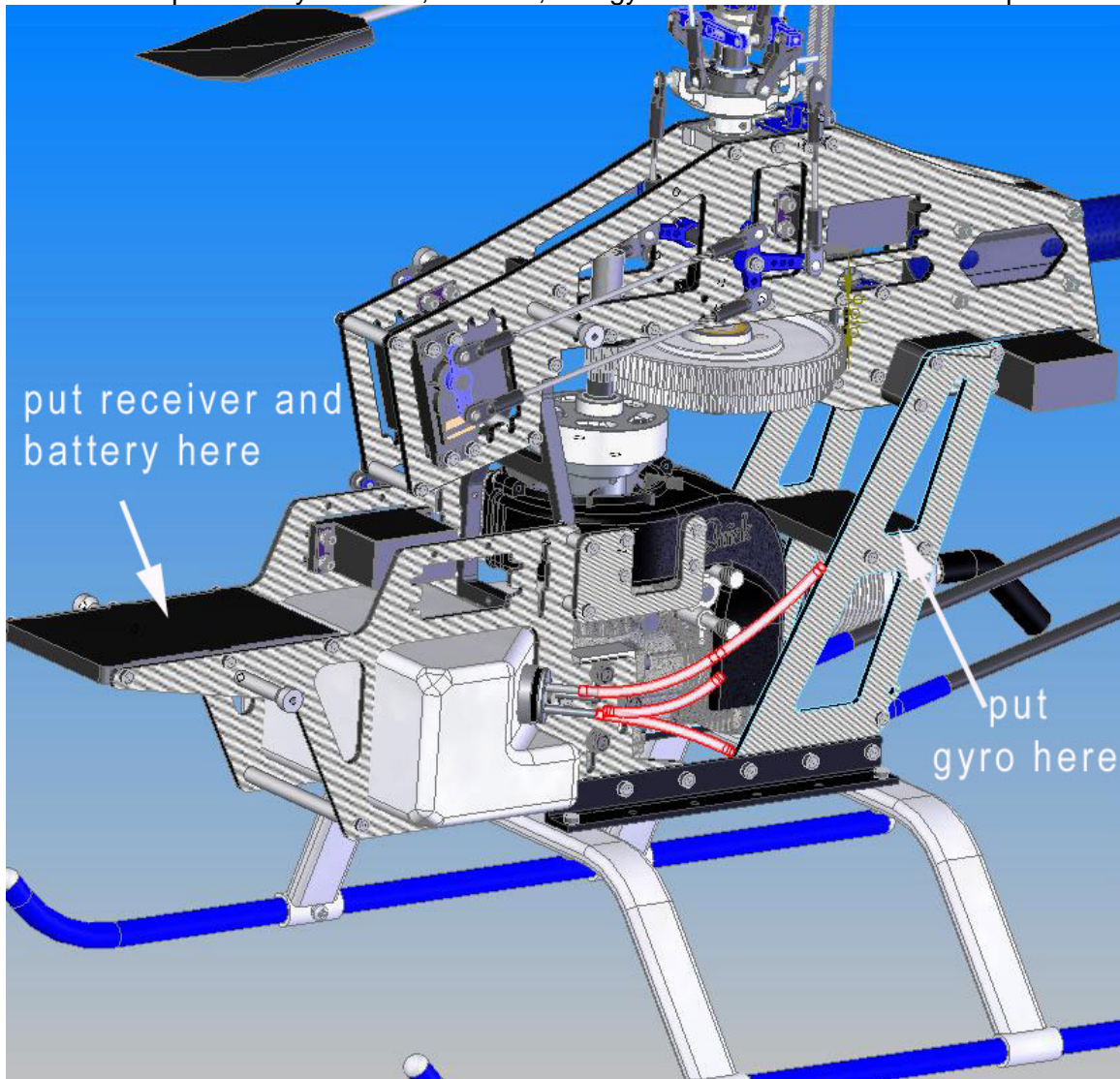

Note: The frame may look differently from the one in the kit.

CCPM Helicopter Setup (for all Quick Helicopters)

General

Instead of giving you the exact length of each linkage rod we will explain to you what you are trying to achieve. This is the same for all Quick helicopters. Another thing worth mentioning is that all controls on our helicopters are leading edge controlled. We have three such controls on our helicopter and they are Main blades, Tail blade and flybar control arms. For example the main blade pitch arms should be mounted so they are in

front of the blades in the direction of travel, clockwise if you look at the helicopter from above, see picture 4.

Your radio manual will be needed during this set up.

Swashplate

First, set your radio so that all travel values are at 100%. If you have a radio with Swash Mixing set, set those values to 50% (Aileron, Elevator, and Pitch.) Then use servo reversing so that all servos are moving in the right direction. If Pitch operates reversed, change the value in the Swash Mixing from + to -.

Step 1: First set your radio up so that all servos are moving in the right direction and adjust all travel values to 100%. If you have a radio with Swash mixing values set those to 50% (Pitch, Aileron and Elevator).

Now center both radio sticks (including "throttle") and center all trim and sub-trim values. When this is done turn your receiver pack on. Now mount the servo arms at a 90° angle towards the linkage rod. In our non push pull helis this will be horizontal. Use the mounting position on the servo arm that will be closest to 90°, not all servos will line up 100% correct. If they are visible off from the 90° position the use the sub-trim function in your radio for fine tuning, do not use regular trim for this, see picture 1.

Now you have a good start and the rest of the setup will become easier.

Step 2: Connecting the Swashplate at the right distance. This is done by moving your Pitch (throttle) stick all the way down, see picture 2. When the servos are in this position adjust the length of the linkage rods so the Swashplate is located towards the bottom, but still leaves enough room for left/right (aileron) and front/back (elevator) travel. During such travel, portions of the Swashplate will move below the Swashplate position archived during Pitch full down radio stick position. So make sure you leave enough room for this extra travel, see picture 2 for recommended height. Also make sure that all 3 linkage rods between the servo arms and the Swashplate are the same, so the Swashplate is level. It should not tilt in any direction; unless your right radio stick is moved. If it tilts, and all linkage rods are the same length, then go back to step one and make sure your three servo arms have the same neutral position (horizontal on non push pull helis).

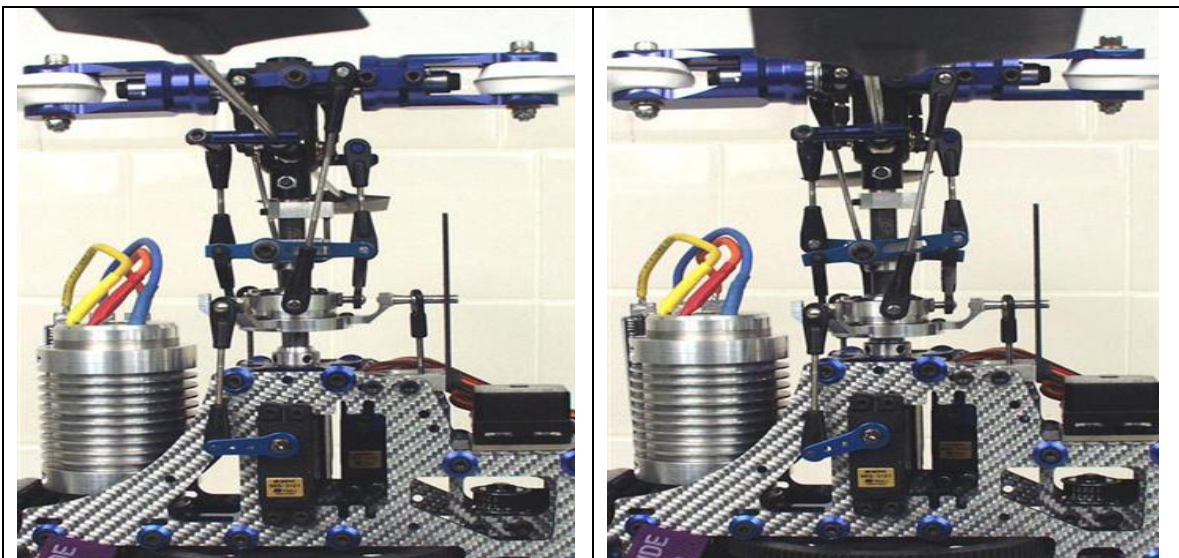

Step 3: Connecting the Washout assembly. Connect the fixed length plastic “A” arms to the Swashplate, connect to the two longer pivot studs, if all four are the same length then any two will do. The next step is to adjust the length of the linkage rod between the Washout Arm and the Flybar connection point. Turn your radio and receiver back on and center both sticks. Now adjust the length of the flybar linkage so the washout arms are level (horizontal), see picture 1. Also make sure your flybar arms and flybar-paddles are level (horizontal), when adjusting the linkage. After the length is adjusted make sure that you have free travel in all directions and stick positions. When the Pitch stick is all the way up it should look like picture 3. As you can see there is still plenty of room for aileron and elevator travel. Now adjust the Washout Anti-rotation pin height so the pin is still in the guide slot of the washout base during all travel positions. For the Left/Right Washout Anti-rotation position, line the attachment point of the plastic washout “A” arm on the Swashplate up with flybar linkage connection point. The imaginary line between these points should be vertical.

Now you are almost done, only one set of links left, and the length of those links will be depending on your desired setup whether it's Aerobatic or normal flying. Please refer to the Pitch travel setup table for this final link length.

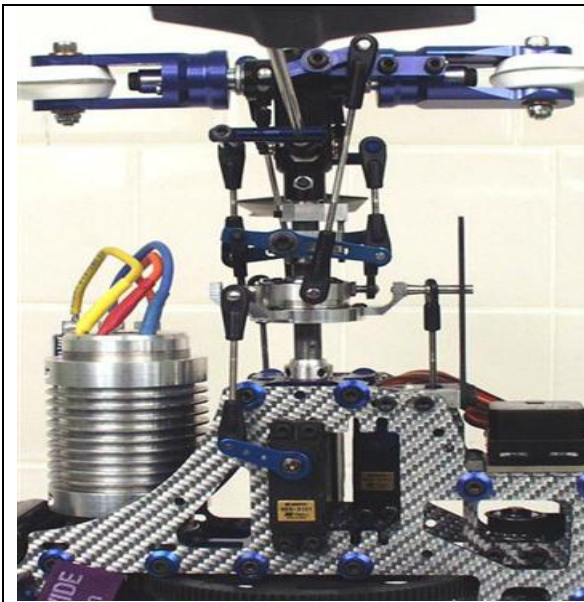

Picture 3, Swash Up

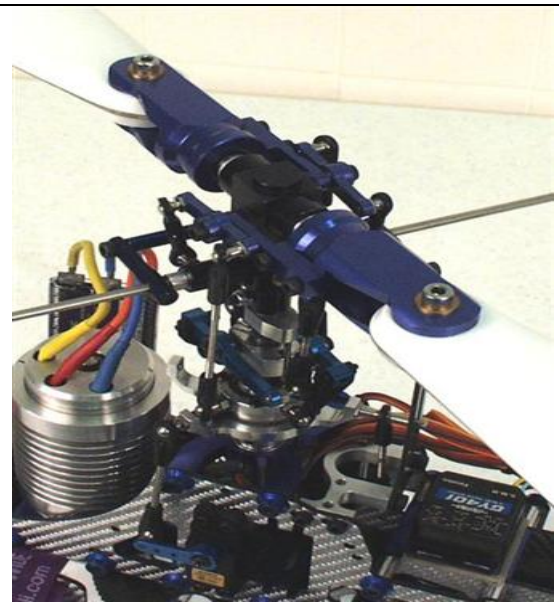

Picture 4, Head

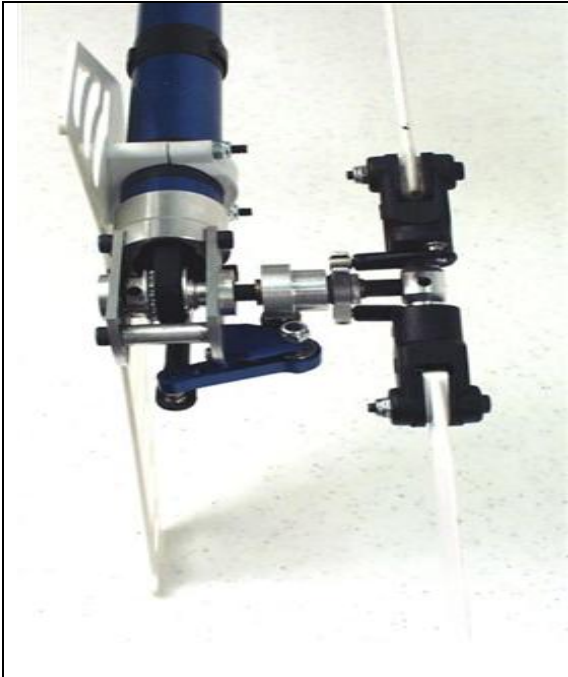

Picture 5, Tail Center

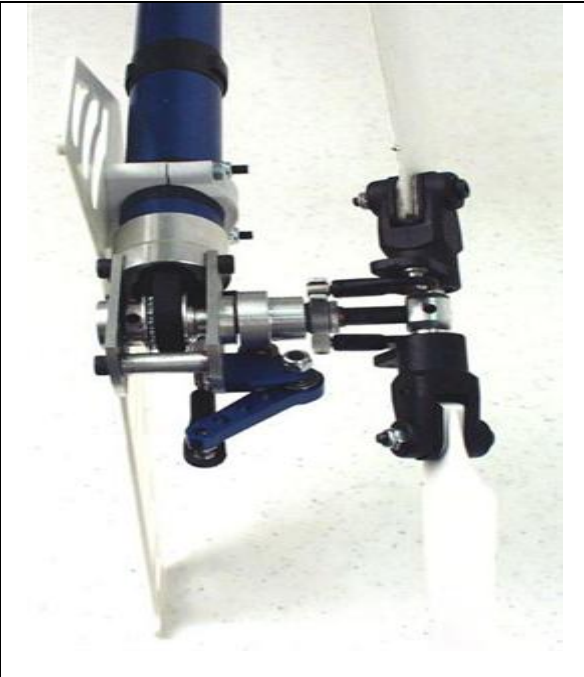

Picture 6, Tail Positive Thrust

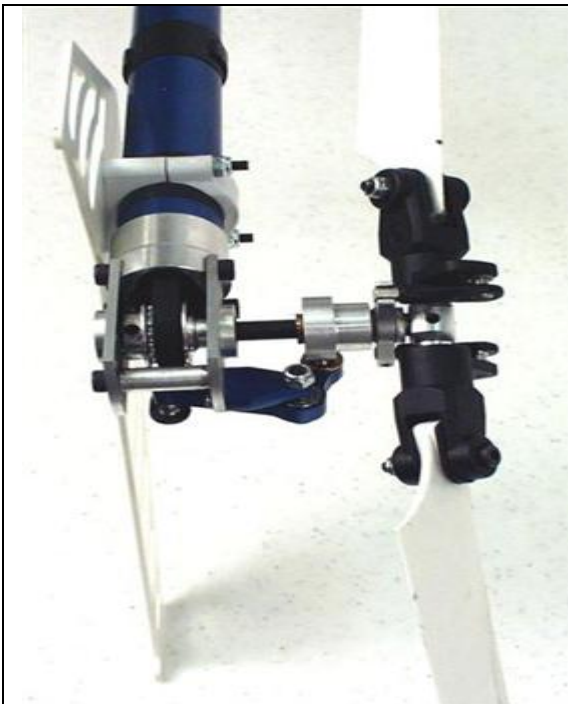

Picture 7, Tail Negative Thrust



Picture 8, Tail

Pitch Travel Setup		
Collective Position	Normal Flying	Aerobatic
Up (100%)	+10°	+10°
Center (50%)	+5°	+0°
Down (0%)	-3°	-10°

Throttle Curve Setup				
Collective Position	Fuel		Electric (non governor mode)	
	Normal Flying	Aerobatic	Normal Flying	Aerobatic
Up (100%)	100%	100%	85%	85%
Center (50%)	70%	60%	75%	75%
Down (0%)	10%	100%	0%	85%

Tail

First adjust the servo arm position like you did with the swash, make sure your trim and sub-trim values are centered. Attach the servo arm so it's 90° to the tail pushrod (vertical). Now adjust your two plastic ball ends, for the push rod, so they are screwed on about half way onto the threaded pushrod guide end piece. This will allow you have maximum amount of adjustment available in both directions. Use the outer holes on the tail blade grips for the ball link attachments. When this is done cut the carbon pushrod to a length that will achieve about 3° of positive pitch on your tail blades, when the servo is in its neutral (vertical) position. Then glue the two end pieces on to the pushrod with CA glue, don't forget to insert the pushrod guides first.

When this is done you should have 3° of positive tail blade pitch. The tail should spin counter clockwise looking at the right side of the helicopter with the nose to your right and tail to your left. See pictures 5-8.

Note: Please consult the instruction for your Gyro for setting the overall travel and limits to ensure proper operation and travel of Tail Pitch Slider.

Throttle

The throttle curve will be affected by several conditions; some of them are, motor choice, blades choice, elevation, temperature, helicopter weight and type of helicopter. So in order to explain this I will explain what you are looking for. Your goal is to achieve a constant head speed once the helicopter is airborne. If you ad pitch (climb) you need to ad power (throttle) to compensate for the added resistance a higher blade pitch creates. If during climb your head speed drops, then you need to add throttle to that particular stick position, and reversed if you have an increase in rpm. If during max climb out you experience an increase in head speed then you need to give the blades a higher pitch, do not try to adjust the max climb rpm by reducing throttle. There are other ways of achieving this by using cyclic mixing, however we will stay away from this for now. Follow the pitch guidelines in the table above, and if you need more pitch at max power because the rpm is increasing, then add pitch. 10° is just a guideline and will work in most setups, but a powerful motor or a light helicopter might need more. For rpm adjustment during anything other than full stick deflection you should use the throttle.

A short recap, adjust throttle to adjust rpm during anything other than full collective. At full collective adjust the pitch. See the Throttle table for general setup.

Final Words

These are guidelines and will get you going but might not be 100% accurate in regards to all helicopters. Especially the throttle curve table should be considered as initial guidelines. As mentioned before it's greatly affected by your equipment. As you become more familiar and proficient with your helicopter you can change the pitch and throttle curves to your flying style.

8-7 CANOPY MOUNTING

No.	Bag#	Description	Qty
1		Helicopter	1
2	In box	Canopy	1
3	8	Canopy Grommet	4
4	HB	M3x10 Cap Head Bolt	4

- Put the Canopy on the helicopter, mark the right positions for 4 holes, and then drill four 5.5mm holes.
- Install the Canopy Grommets on the Canopy.
- Secure the Canopy by 4 M3x16 Cap Head Bolts.

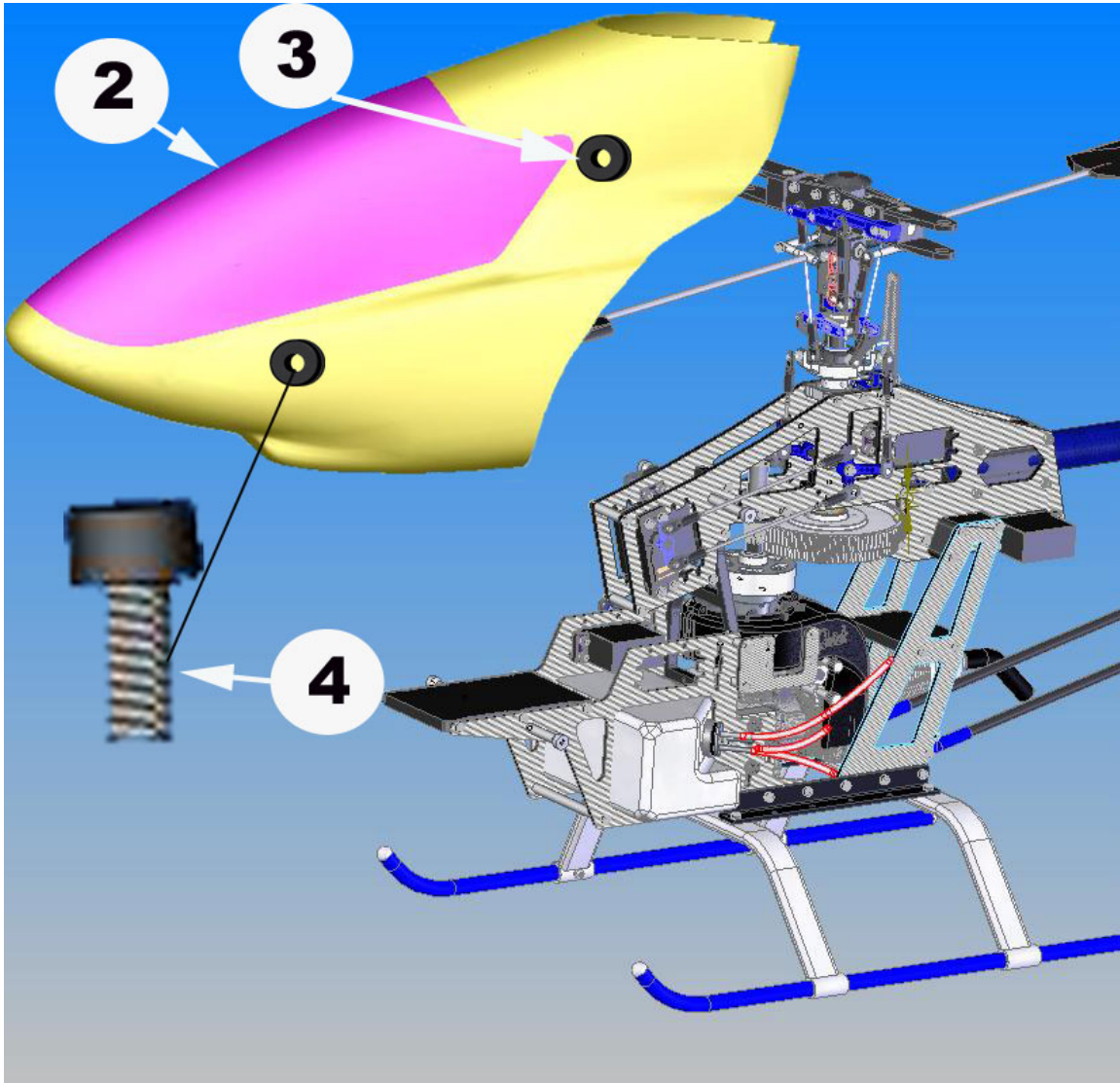

Note: The frame may look differently from the one in the kit.

PRE-FLIGHT CHECKS

- The rotor flybar and shaft must be straight.
- The flybar and control paddles must tilt in the proper direction and operates smoothly throughout the whole range.
- Check the swashplate to make sure it move smoothly and clean.
- When control input are given to tilt the swashplate, make sure no control arms or pushrods are binding.
- Check the two control paddles for level, parallel, and proper direction.
- Make sure the batteries are fully charged and the fuel tank is full.
- Make sure the radio and receiver are on and all controls operate properly before flight.
- There should be no interference of radio signal in your flying zone. Range check the radio.
- Always grab onto the helicopter main rotor head when turning on the helicopter.

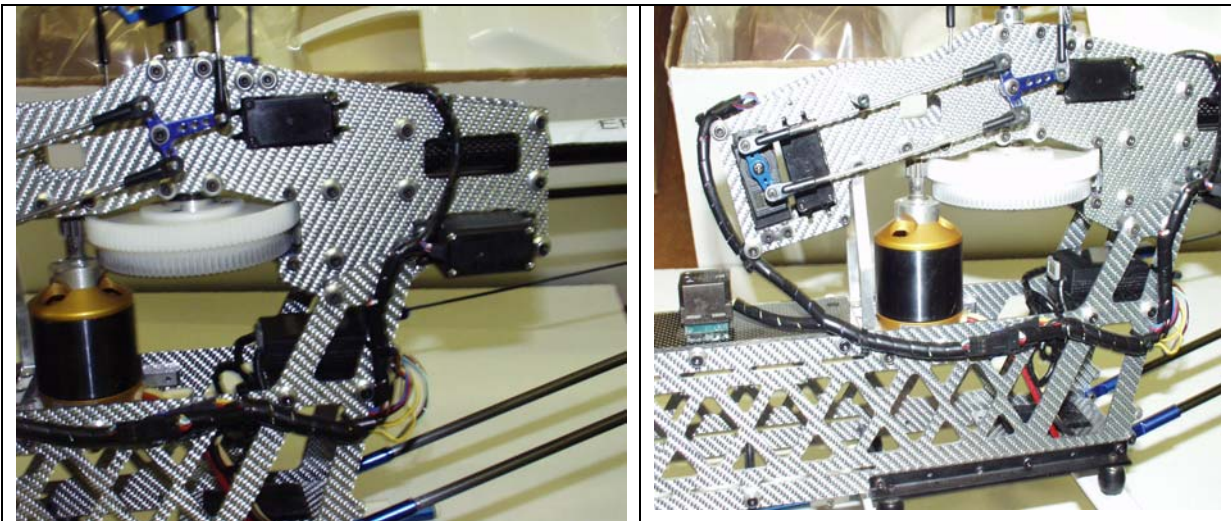

These pictures illustrate how everything should be neatly wired up and strapped down before your helicopters first flights.

WARNINGS

- Do not operate helicopters in rainy, windy, or snowy condition.
- Operate helicopter in a safe zone away from crowds, traffic, or distractions.
- Use the proper batteries to prevent damage to the motor and equipment.
- Make sure all the batteries are fully and properly charged and the fuel tank is full.
- Make sure all the controls operate properly before flight.
- The main and tail rotors blades operate at very high speed (rpm); therefore, make sure nothing can come into contact with them while they are spinning.
- Perform a range check on the radio before flying.
- Make sure the transmitter and receiver are turned on before starting the engine
- Keep a safe distance when operating a helicopter.
- Do not fly for a long period of time. Take some rests during flights.
- Motors are often very hot after operation. So be careful when handling or touching them immediately after flying.

ADJUSTMENTS

Tracking Adjustment: The tips of the main rotor blades should follow the same path when they rotate. We call the main rotor blades are in track.

(a) Rev up the motor until the helicopter becomes light on its landing gear.

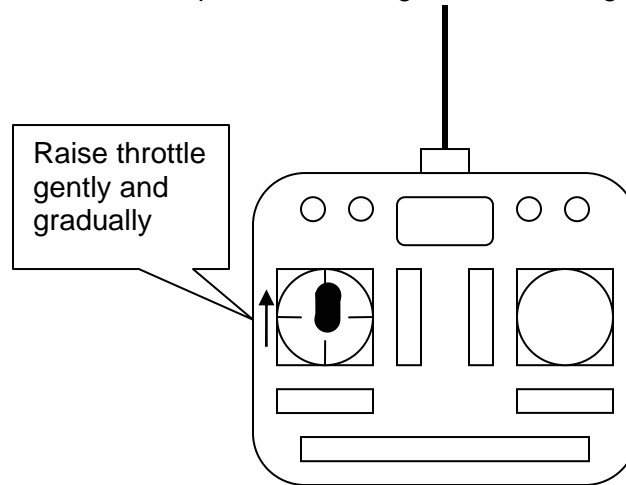

(b) If the main rotor blades are in track, it's good.

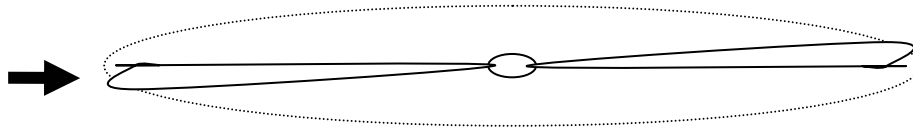

(c) If the blades are out of track, then adjust one of the pushrods that connect to the main rotor blade pitch arm.

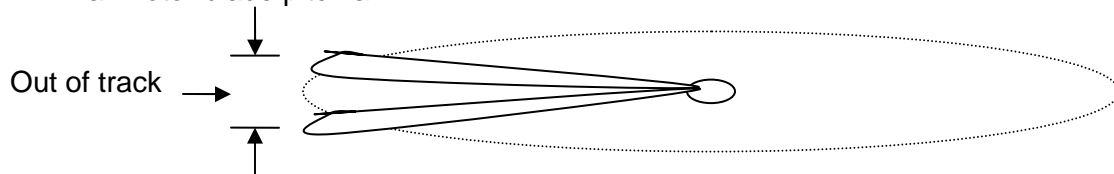

Repeat steps (a) to (c) until the blades are in track.

Trimming: Most of new built helicopters are unstable. But if you trim your helicopter properly, you will stop it from drifting away or yawing by itself quickly. Followings are instructions for trimming your helicopter.

(a) If the helicopter nose starts to yaw left or right, adjust the tail rotor push rod to compensate. If using a Heading Hold Gyro, do not adjust the trim lever on the radio.

(b) If the helicopter rolls to left or right, then:

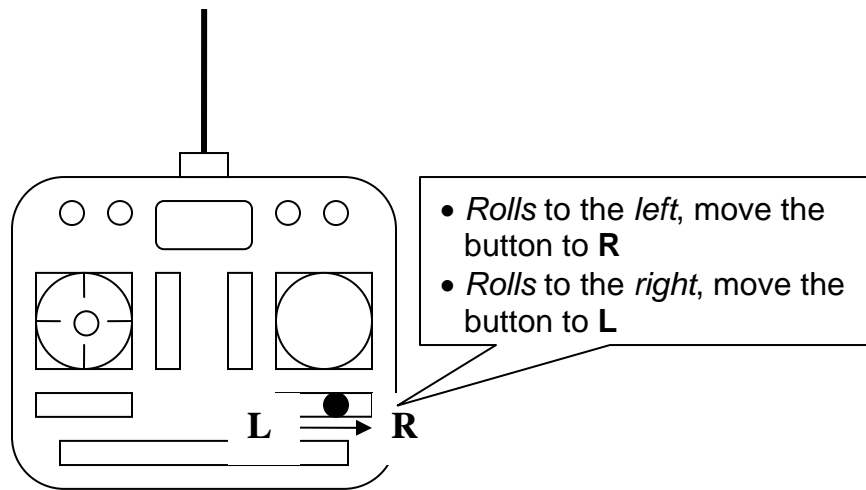

(c) If the helicopter nose goes down or up, then:

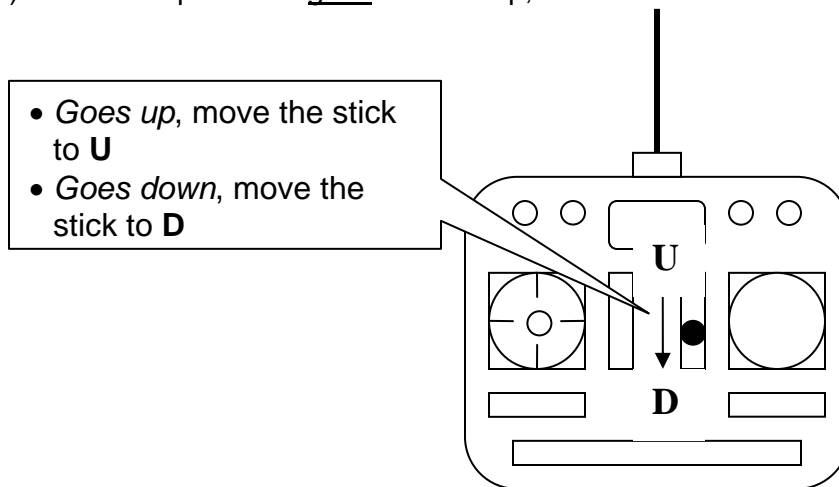

HOW TO HOVER

Basic maneuver for a pilot is learning how to hover a helicopter. When the helicopter is floating in a stationary position in the air, we call that hovering. Use the following procedure to practice your hovering:

- (a) Make sure everything is clear in the flying zone. Stand at least 30 feet (10 meters) behind the helicopter.
- (b) Check the main rotor fore/aft and left/right cyclic to make sure the main rotor is following to your cyclic command before taking off. Make sure the helicopter nose will swing in your desired directions by moving the tail rotor control stick.
- (c) Now, increase the throttle/collective gently to lift the helicopter landing gear off the ground to no more than 4 inches (10 cm). At the beginning, it is very difficult for the pilot to keep the helicopter from moving. It will also be difficult to know if the helicopter is in trim or not for a beginner. Keep going on the practice close to ground you will develop your skills.
- (d) Keep practicing lifting your helicopter no more than 8 inches (20cm) from the ground until you feel comfortable with control commands. Once you can keep it at one place, then it is time to slowly increase the height a few inches in each flight. Soon, you will

be able to hover the helicopter confidently at a few feet high. Beginners should always practice hovering close to ground since in an emergency situation; you can drop the throttle and collective quickly without making any big damage.

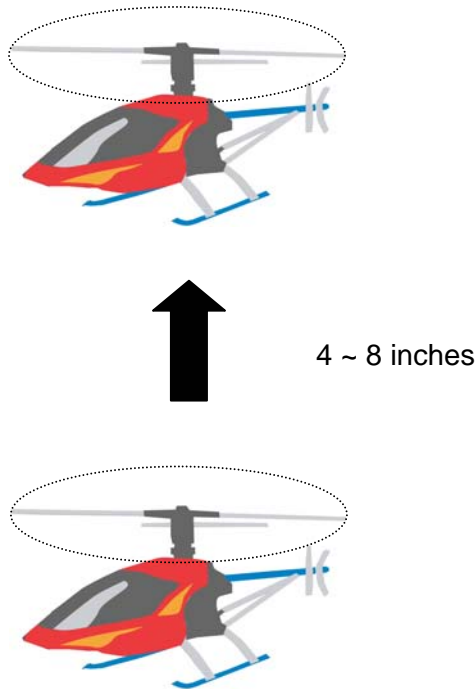

- (e) Stand behind the helicopter so you can watch the nose of the helicopter. A left tail rotor command will yaw the helicopter nose to the left, and a right command will yaw to the right. Also, a left cyclic command will cause the helicopter to translate left., Start practice hovering while standing to either side of the model after you can comfortably hover the helicopter at 3 feet (1m) high without drifting. Finally, you need to learn hovering the model from any positions. When you can confidently hover a helicopter at any altitude and at any position, you have mastered most of the fundamental control movements of a helicopter.

HOW TO FLY FORWARD

Once you have mastered hovering flight:

- (a) Let's begin the exercise of changing positions by practice moving the helicopter to the left or right slowly from 60 inches (1.5 m) above the ground.

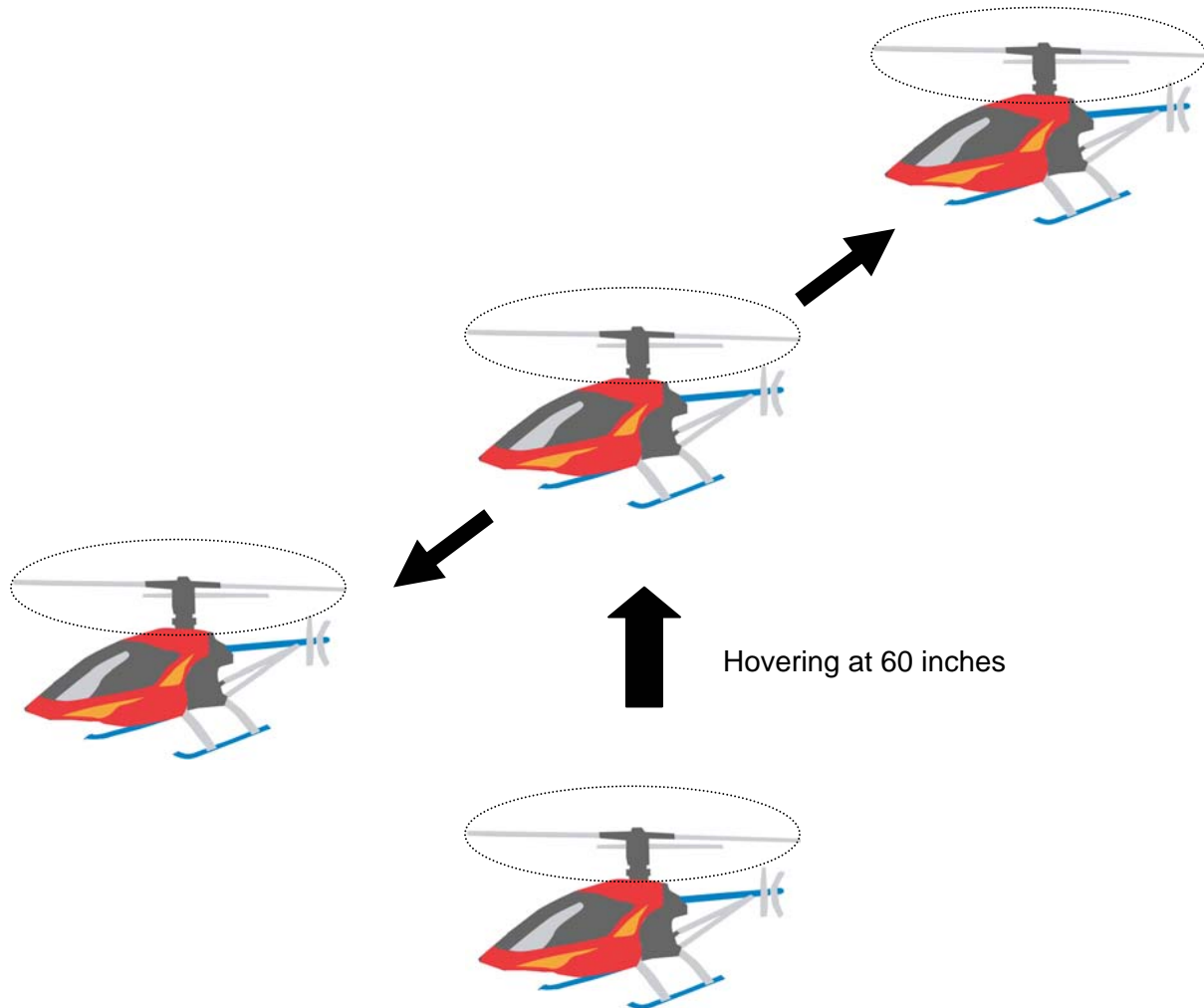

- (b) Once you have been comfortable with all the movements and controls in the previous step, start using some tail rotor control to make the helicopter point slightly to the left or right as you fly it to the left or right. Keep practicing the figure-eight path as shown below, you will master all basic control movements of a helicopter.

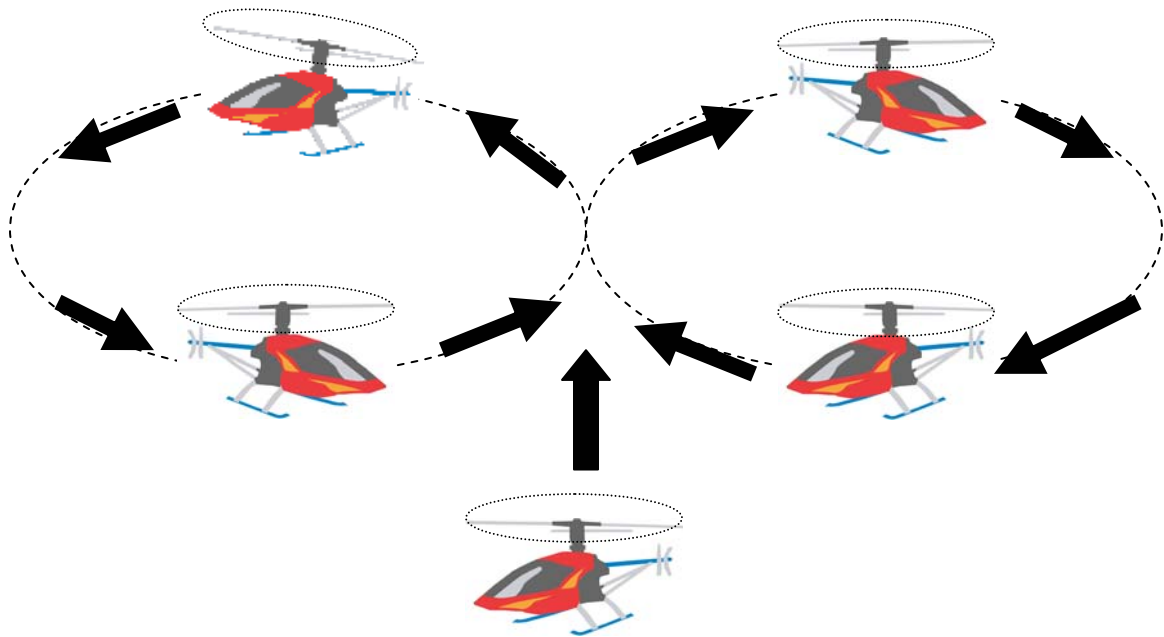

AFTER-FLIGHT CHECKS

After each flight, the helicopter should be thoroughly inspected:

- (a) Unplug the batteries.
- (b) Check every bolt, nut, and screw to make sure none has loosened due to vibration.
- (c) Check every rotating and movable part like head rotor, swashplate, tail rotor, to ensure they still move smoothly and properly.
- (d) Check all movable parts, such as gears, ball links, belt, etc. for unusual wear.
- (e) Clean up the helicopter then lubricate every moving part with oil to ensure a smooth operation in the future.
- (f) Keep the helicopter in a cool and dry place. Avoid storage under direct sun light or near heat.
- (g) Please replace any damaged parts if they are discovered during maintenance.

WHAT IF THE HELICOPTER CRASHED

Turn off everything and check the helicopter immediately. If any item is damaged, replace the damaged parts to ensure safe operation. Do not try to glue any broken or damaged plastic or carbon parts specially broken rotor blades. The followings are parts that should be inspected right away:

- Main and tail rotor blades.
- Flybar, main shaft, head spindle, and tail output shaft.
- All the gears.
- Tail boom and supports for cracks.
- Vertical and horizontal fins.
- Frames.
- All pushrods.
- Servos, motor, and batteries.

SPECIFICATIONS

Specification	Quick 50
Blades	Quick 580-600 mm
Length	1115 mm
Height	450 mm
Fully Equipped Weight	~ 7.5 lbs (3.40 kg)
Engine	50-70
Frame Thickness	2.0-2.2 mm
Spindle	8.0 mm
Main Shaft	10 mm
Canopy	Fiberglass
Flying	Aerobatic / 3D