

# X-CELL

**SIXTY SERIES HELICOPTERS**

With #0546 Uni-Ball Clutch System

## INSTRUCTION MANUAL

[www.rhelibase.com](http://www.rhelibase.com)

**PART NUMBER: 0503**

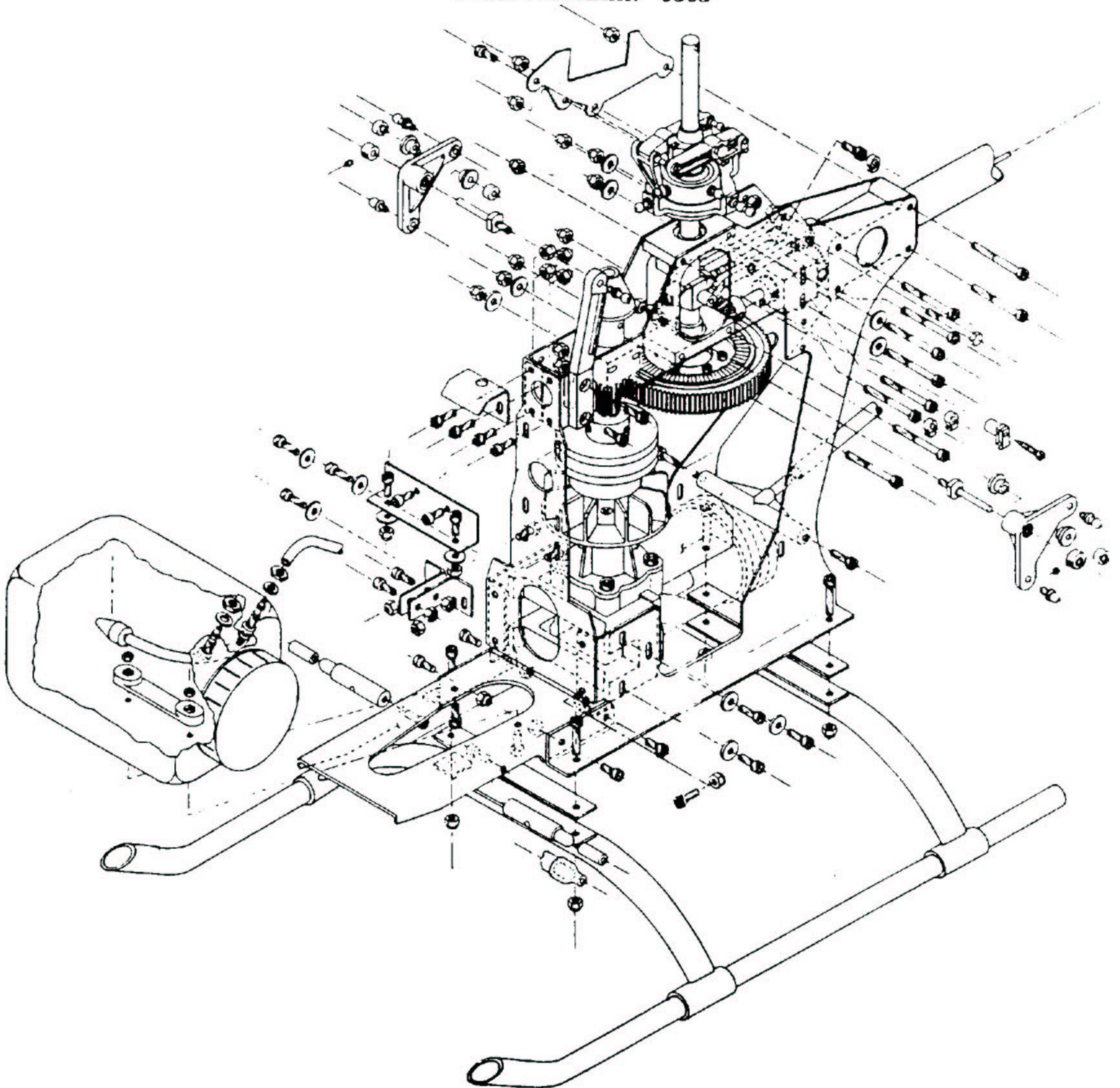



# X-CELL .60 SERIES HELICOPTER

With #0546 Uni-Ball Clutch System

## INTRODUCTION

*Congratulations!* You have just purchased the highest quality Helicopter kit available and one which will build up in a short time into the finest flying helicopter on the market today!

There -- the conventional introduction has been taken care of!

If you just skimmed through it, that's fine. It was there just to get you up to speed anyway. Be warned, however, that is one of very few paragraphs that you dare skim through in this Construction Manual!!

We won't list all of the features of the helicopter here either. You probably read our brochure before buying the kit and it lists over forty impressive features. If you gave your copy to a friend, there is another in the kit. After you refresh your memory, give this one to another friend.

Briefly, this is a light weight, beautifully performing chopper that is ruggedly built of quality materials embodying state-of-the-art design and engineering. This Construction Manual will attempt to do justice to it. Read on.....

## SYSTEM REQUIREMENTS

*In addition to the kit, you will require:*

### ***1. A Helicopter Radio with 5 Servos***

Typically, such a radio provides 5 or more channels to control Fore and Aft Pitch (Elevator); Roll (Aileron); Yaw (Rudder); Throttle; and Collective Pitch (changes pitch of both main blades together to vary lift). Throttle and Collective Pitch servos are controlled together by the normal throttle stick movement. This arrangement not only provides adequate servo power for all functions, but also allows important channel mixing functions to be provided by the transmitter.

In any event, it is recommended that any system used incorporate powerful, precise centering, ball bearing servos in order to realize optimum performance from this very responsive helicopter.

### ***2. An Engine and Matching Muffler***

Since the Standard .60 is offered in a .60 (10cc) version, a wide choice of engines are available. Its light weight allows good performance with virtually any modern two-stroke engine in good condition; this characteristic, coupled with outstandingly "tight" and balanced control response, provides unequalled performance with the higher power engines.

A matching muffler is required in a configuration that directs the exhaust down and away from the engine when mounted in the helicopter position. Miniature Aircraft, USA provides a wide selection of mufflers and tuned pipes ideal for helicopter use, as well as offering several engines especially selected to provide top performance.

### ***3. A Rate Gyro***

Probably the one advance in model helicopter technology that contributes most to easy and enjoyable flight is the insertion of an "angular rate sensitive" gyroscope in the yaw (rudder) servo lead from the receiver. This device senses even minute swings of the helicopter nose (yaw) left or right and makes immediate corrective inputs to the tail rotor servo to counteract these movements. This action is not to be confused with that of an "autopilot" in that it does not keep the helicopter pointed in one direction. The amount of its corrections depends on how sharply the nose begins to swing - a small correction for a small amount, or a larger correction for a larger amount. In other words, the gyro response varies with the angular rate of change, which is why this particular type of gyro is called a "rate" gyro as distinguished from a "position" gyro.

The important effect is to make the helicopter much easier to control, and it is highly recommended that a gyro be used in the X-CELL. Miniature Aircraft, USA has offered rate gyros to modelers since their inception and currently stocks units ideal for all helicopter use.

It is essential to have your Radio and Engine on hand before beginning kit construction because they will

be needed fairly early in the building sequence. The Muffler and Gyro are not such immediate needs except that the gyro control switch box is easier to install early.

## CONSTRUCTION

The Standard .60 helicopter kit has been designed for easy and straight-forward assembly but, like any precision device, considerable care should be taken and work should progress in a methodical and orderly fashion.

Please read these instructions thoroughly, prepare your work place, and get all required tools together before you begin.

## THE KIT PACKAGE

The kit includes detailed drawings showing all parts - with numbers - in proper relation to each other in easy to understand subassemblies. Also included is a detailed pictorial fastener list, radio and servo installation, and set-up data such as exact push rod lengths where possible, and a metric scale for your convenience. Metric hardware is used because its design and quality are superior for use in precise mechanisms.

By taking out just the major parts and the bag of small parts called for in any assembly step, confusion between similar parts and fasteners can be minimized.

Also in the box will be a small bag of spare parts such as nuts and bolts. A package containing Allen wrenches and certain other special tools needed for construction is also included.

## TOOLS REQUIRED

In addition to the tools listed below, it is quite important to have a good place to work. An actual workbench is not needed because no metalworking (filing, etc) is required and just the blades and fiberglass canopy require material removal and sanding operation. Your work table should, however, be protected from marring by the various metal parts used.

- Screwdrivers - both slotted and cross-recess (Phillips Head) #00, #1
- Long-Nosed Pliers
- Tweezers
- Hand Drill with appropriate bits
- Dremel Power Tool or equivalent
- Small Fine File
- 5.5mm Open End Wrench (can be 7/32")
- 7mm Open End Wrench (can be 9/32")
- Allen Wrenches (supplied in kit)
- Appropriate Socket Wrench for your engine shaft nut
- Vinyl Two-Sided Servo Tape 1/8" (#3869)
- Glowplug Wrench (Part #4648)
- Scissors
- Slow Zap (#4917)
- Thin Cyanoacrylate Glue (#4881)
- Loctite (MA/USA) thread lock liquid (supplied in kit)
- (NOTE: Use only the material supplied or its EXACT equivalent)
- Masking tape, Paint for finishing Canopy, 80 and 220 Grit Sandpaper
- Heat Gun (Monokote type)
- Grease, Teflon Filled (Order #4709 - 2 oz tube, or #4707 - 1 oz syringe)
- Tri-Flow Teflon Oil (Part #4801)
- J.B. Weld Epoxy (#4853)

In addition, the following will make assembly easier and prove useful later, in your model toolbox:

Ball Link Application Tool (part #0529)  
5.0mm Nut Driver (#4669)  
5.5mm Nut Driver (Socket on a Handle) (#4670)  
7mm Nut Driver (#4671)  
Fan Drive Collet O.S. SX (#0262)  
Fan Drive Collet 7mm Enya 60 (#0265)  
Fly-Bar Alignment Kit (#0510)  
Universal Swashplate Lock (#0512)  
1.5mm Allen Wrench on a Handle (#4651)  
2.0mm Allen Wrench on a Handle (#4653)  
2.5mm Allen Wrench on a Handle (#4655)  
3mm Allen Wrench on a Handle (#4657)  
Ball Link Pliers (Part #0545)  
Pitch Gauge (Part #0526)  
Flybar Lock (Part #0505)  
Tail Rotor Blade Balancer (Part #3750)

These tools can be obtained from your local hobby shop, or ordered directly from Miniature Aircraft, USA.

### ASSEMBLY INSTRUCTIONS

The instructions to follow will build up subassemblies and incorporate them in the helicopter in a logical sequence. The subassemblies will be clearly recognizable on the main drawing as will the parts and fasteners used. Take a few minutes to carefully study the entire drawings before beginning assembly. Note that the drawings include a series of "exploded" views which show the various subassemblies with the individual parts shown unassembled but in relative positions which make obvious the manner in which the parts fit together to create the subassembly.

Each assembly step will begin with an exact list of parts required including locations in the kit box where appropriate. There is essentially no difference in assembly operations. It will be helpful to have a small dish, or box available in which to place the small parts, bolts and nuts for each step for easy access. Any special tools required will be called out in the text.

**NOTE:** Beginning the assembly sequence with the Rotor Head rather than the basic Main Frame Structure may seem unusual but allows the use of the engine start/clutch shaft as a very effective alignment tool to facilitate Rotor Head assembly before the shaft itself is assembled.

### ASSEMBLY SEQUENCE

#### **I. ROTOR HEAD ASSEMBLY** p-17

- STEP 1. Install The Pivot Block into the Head Block  
2. Final Assembly of the Fly-Bar Yoke, Guide Pins and Head Button  
3. Building and Installing the Bell Mixers  
4. Assemble and Install the Main Blade Mounts  
5. Add the Fly-Bar, Control Arms and Head Bolt  
6. Assembly of Flybar Paddles

#### **II. BUILDING THE TOP MAIN FRAME SECTIONS** p-14

- STEP 1. Assemble Aileron (Roll) Bellcranks to Main Frames and Mount Tail Push Rod Guides  
2. Assemble Elevator (fore and aft) Swing Arm Unit  
3. Install Main Shaft Bearing Blocks

4. Assemble Front Tail Drive Transmission
  5. Install Front Tailboom Support Halves
  6. Assemble and Install Start Shaft Bearing Block
- III. **ASSEMBLY OF THE MAIN SHAFT COMPONENTS** P-18
- STEP 1. Alignment and Tightening of Bearing Block Assemblies
2. Installing the Mainshaft, Autorotation Unit with Maingear
  3. Assembling Swashplate
  4. Assembling Lower Swashplate Control Rods and Anti-Rotation Arm
  5. Assembling Wash-Out Unit
- IV. **ASSEMBLE OF FRONT FRAME SECTIONS** P-19
- STEP 1. Assembly of Front Vertical and Tank Support
- V. **INSTALLING ENGINE AND FAN SHROUD ASSEMBLIES** P-20
- STEP 1. Mount Flywheel
2. Installation of Clutch Assembly and Align Engine
  3. Installing Engine and Fan Shroud Braces
  4. Installing the Fan Shroud Assembly
- VI. **INSTALLATION OF LANDING GEAR ASSEMBLY** P-21
- STEP 1. Assemble Landing Gear and Install
- VII. **RADIO TRAY ASSEMBLE AND SERVO INSTALLATION** P-24
- STEP 1. Installation of Radio Tray Frame Supports
2. Mount Servo's into Plastic Tray Components and Assemble Plastic Tray
  3. Mount Plastic Tray to Main Frames and add Front Brace
  4. Mount Elevator Servo
- VIII. **INSTALLING FUEL TANK SYSTEM** P-22
- STEP 1. Assemble Fuel Tank
- IX. **ASSEMBLE THE TAIL ROTOR TRANSMISSION** P-23
- STEP 1. Assemble Tailrotor Hub and Blade Holders
2. Assemble Pitch Slider and Bellcrank
  3. Assemble Gear Box
  4. Install Assembled Tail Rotor Hub
- X. **BUILDING THE TAILBOOM** P-25
- STEP 1. Installing Wire Drive
2. Installing the Tail Rotor Pushrod Guides and Fin Mounts P-26
- XI. **INSTALLATION OF REMAINING RADIO EQUIPMENT, ASSEMBLING AND INSTALLING PUSHRODS**
- STEP 1. Install the Switch for the Receiver, Gyro, Radio Receiver, Battery and the Antenna
2. Install Rudder Pushrod

3. Install Elevator Pushrod
4. Install Aileron and Collective Pushrods
5. Install Throttle Pushrod
6. Rotor Head and Fly-Bar Hiller Control Rods

**XII. CANOPY PREPARATION** *P-445*

- STEP 1. Assemble Canopy and Paint

**XIII. BUILDING THE ROTOR BLADES** *P-445*

- STEP 1. Assembling Blade Mounts  
 2. Adding Lead Strips  
 3. Initial Balancing  
 4. Cover Blades  
 5. Final Balance of Blades and Rotorhead  
 6. Adjustment of Static Tracking

**XIV. FINAL MECHANICAL AND ELECTRICAL SET-UP** *P-49*

- STEP 1. Collective Servo and Collective Arm  
 2. Final Swashplate and Fly-Bar Alignment  
 3. Adjusting Pitch Curves  
 4. Adjusting Swashplate Throw  
 5. Adjusting Rudder  
 6. Gyro  
 7. Elevator and Aileron Dual Rates and ATV

**XV. FINAL ASSEMBLY AND BALANCE** *P-51*

**XVI. FINAL ASSEMBLY INSPECTION** *P-51*

**XVII. NECESSARY FLIGHT ITEMS** *P-51*

**XVIII. STARTING AND STOPPING ENGINE** *P-52*

**XIX. FIRST FLIGHT ADJUSTMENTS** *P-52*

## I. **ROTOR HEAD ASSEMBLY**

**NOTE:** At the builders discretion the bearings and shaft in this section may be glued together using Loctite (red, green, or blue). If you choose to do this the disassemble process will become very difficult and will require the application of heat to break down the glue.

### **Step 1. Install the Pivot Block into the Head Block**

Parts Required:

2	#0033	M3x5 Phillips Machine Screws	Bag 1B
1	#0289	Head Block	Bag 1A
1	#0294	Long Pivot Block	Bag 1B
2	#0301	Pivot Ball Bearings	Bag 1B
2	#0563-1	Brass Inserts	Bag 1B
2	#0563-2	M3x8 Socket Set Screws	Bag 1B

***Refer to Drawings #1.***

- A. Clean the I.D. of the pivot ball bearings #0301 and the long pivot block #0294 using a paper towel and some thinner. At builders discretion apply a very small amount of locktite to the shaft on both sides of the pivot block. Slide the bearings all the way on the block, one on each side. (If necessary, tap into place, applying force only to the inner race.)
- B. Identify the two small holes recessed at the end of the middle bore in the #0289 head block and squarely thread an M3x5 Phillips head screw #0033 into one hole until it seats. Do not over-tighten. Slide the pivot block unit into the middle bore from the other end until it seats against the screw head previously installed. Thread the other M3x5 phillips screw into the remaining hole until it seats and traps the pivot block assembly. Neither screw should be so tight as to bind the bearings. Instead, they should be adjusted equally so that neither end play nor binding exist.

#### C. **Installing Static Tracking Screws**

**Purpose:**

To allow adjustable static tracking of the rotor head due to slight variations in blade height at the tips by eliminating any looseness about the mainshaft due to wear or stretching of the base of the head block.

Special Tools Required:

- 1 Small Hammer

Examine the head block #0289 closely. On each side (at the base) just above where each #0297 pin is installed, you will notice a hole molded in the plastic.

Select an M3 bolt from the spare parts and screw it 3/4 of a turn into the knurled end of one of the brass inserts (#0563-1). Hold this straight with respect to the hole and use light tapping pressure on the bolt head (with a small hammer) to start the insert into the hole. When you are satisfied that the insert has started into the hole straight, remove the M3 bolt and use the hammer to set it flush with the head. Due to it's slotted construction and knurled edge, the brass insert will "set" itself firmly into the plastic. No Cyano is required. Repeat the process on the other side.

Again, using an M3 socket-head bolt from your spares, it is now necessary to test the threads. Screw the bolt into the insert slowly. It will have some resistance and possibly squak a little. This is fine since this process will spread the insert deeper into the sides of the hole. Remove the bolt and repeat on the other insert.

Start each set screw #0563-2 and screw in until it is flush with the surface of the rotor head. Final adjustment will come after the main rotor blades have been mounted.

## Step 2. Final Assembly of the Flybar Yoke, Guide Pins, and Head Button.

### Parts Required:

4	#0063	M3x10 Socket Head Bolt	Bag 1C
2	#0115	M3x10.5 Threaded Ball	Bag 1C
2	#0292	Flybar Yoke Halves	Bag 1C
2	#0296	Pivot Block Spacers	Bag 1C
2	#0297	M2.5x24 Guide Pins	Bag 1C
2	#0298	Delrin Bearing Cups	Bag 1C
2	#0299	Flybar Bearings (M4x10)	Bag 1C
2	#0339	Delta III Plates	Bag 1C

### *Refer to Drawings #1.*

- A. Rotate the pivot block until the cross hole is squarely visible through the side slots in the head block (it may be held in this position using the clutch shaft of the clutch assembly #0267). Slide one #0296 plastic spacer onto each end of the exposed shafts from the pivot block #0294. Holding the pivot block cross hole level within the head block and press one #0292 flybar yoke half (rounded side outward) fully onto each end of the pivot block. Align each flybar yoke half with the "tool" leveling the pivot block. This step is important but not critical since the through hole in the pivot block is only a "clearance hole" for the flybar to pass through.
- B. Examine each #0298 Delrin bearing cup. Note that one side is made to accept an #0299 (M4x10) bearing with a snap fit. Insert one #0299 bearing into each bearing cup, making sure that it is fully seated. Select both #0339 delta offset plates. The O.D. of each #0298 bearing cup is designed to snap into the delta offset plate. Install one into each plate.

For your convenience, temporarily apply a small piece of tape on each side of the rotor head block and designate one side as the left side and one as the right side. Examine each delta offset plate carefully. You will see that each is symmetrical with the exception of a protruding end with an M3 threaded hole. Holding the rotor head block with the left side facing you, position one delta offset plate up against one end of each flybar yoke half (aligning each unthreaded hole in the plate with each flybar yoke half hole) with the M3 threaded hole offset to your right. Install two M3x10 socket head bolts with a small amount of slow cyano through each delta offset plate and into each flybar yoke half. Be sure that the bearing faces outward. Rotate the head block 180° and repeat the process. This pivot block/delta plate assembly should now pivot freely and the through hole in the pivot block should be in alignment with each M4x10 bearing.

Apply a small amount of Loctite to each #0115 threaded ball and install them from the outside into each delta offset plate. Note that each will slightly scuff against the head of the nearest M3x10 socket head bolt during installation. This will not cause any problem. Be sure each #0115 ball is fully tightened.



- C. Drive the two #0297 guide pins into the bottom holes in the head block until they seat solidly. (They will project about 16.0mm when seated.) **NOTE:** The lower 8mm of the pins #0297 may be roughened with 80 grit sandpaper and press in place with epoxy or slow cyano.

### Step 3. Building and Installing the Bell Mixers

#### Parts Required:

2	#0017	M3 Nuts	Bag 1D
2	#0093	Special Bell Mixer Screws (M3x18)	Bag 1D
4	#0115	M3x10.5mm Threaded Balls	Bag 1D
4	#0159	Ball Bearings for Bell Mixer (M3x7)	Bag 1D
2	#0317	Main Blade Mounts	Bag 1A
2	#0333	Bell Mixers	Bag 1D

#### *Refer to Drawings #1.*

**NOTE:** This is the first step involving the threading of control link balls into plastic parts and three important requirements must be met. First, the ball thread must be started squarely in the hole. This is assured by first pushing the ball onto the allen wrench (a quality feature of this kit is the series of standard .60 control balls used that have hex sockets in the end), and carefully starting the threaded end into the hole as squarely as possible. This can be determined by alternately viewing the ball and wrench from two aspects 90 degrees apart ("backing up" the thread a small amount before turning in the normal direction will help prepare the plastic hole to accept the screw thread). Second, a small amount of slow cyano acrylate glue must be applied to the thread. Normally this can be done to the remaining threads after the part has been threaded halfway on. Be careful not to get glue on the ball or your fingers -- use a toothpick. Third, the ball must not be threaded in so tightly that the threads created in the plastic are stripped. Each ball has a flange intended to seat against the plastic part, so thread the ball down until this flange just contacts the surface.

- A. Thread two long shank threaded balls #0115 into each #0333 bell mixer. Use slow cyano and be sure to thread in squarely without over-tightening.
- B. Using a #0093 bell mixer screw to assist in alignment, press a #0159 ball bearing into each side of each #0333 bell mixer. Be sure the bearings are square and properly seated.
- C. Examine the #0317 blade mounts. Two holes are provided on each pitch arm for the installation of the bell mixers. For the purpose of this particular model, you will only be using the hole **nearest** the main body of the blade mount. Upon further examination, you will find a small raised area surrounding each hole. Since the outer hole is **not** to be used, it is advised that you remove the small raised area from that hole. A sharp knife will do this easily. This will provide suitable bearing clearance when the bell mixer is finally installed in the other hole.

With the stepped side facing away from the head of #0093, slide each bell mixer assembly on a #0093 bell mixer screw and thread into the hole nearest the main body of each #0317 blade mount. Using Loctite, thread a #0017 M3 nut on the exposed threads of #0093 screw on the inside of the blade mount arm. Tighten the nut securely against the inside of the control arm. Do not be alarmed if the nut takes on a slanted appearance after light tightening -- its function is solely as **extra** security and is not at all critical (should you wish, the nut may be completely eliminated by putting a small amount of slow cyano or epoxy over the exposed threads - it is your option). Apply slow cyano to the nut against the plastic, as a fillet. Be sure each bell mixer is adjusted to allow for no drag or free play.

#### Step 4. Assemble and Install the Main Blade Mounts

##### Parts Required:

2	#0021	M4 Locknuts	Bag 1E
2	#0082	M4X45 Socket Head Bolt	Bag 1E
2	#0085	M5x16 Socket Head Bolt	Bag 1E
1	#0315	Main Blade Axle	Bag 1E
1	#0316	10mm Fuel Tubing	Bag 1E
4	#0319	Ball Bearings	Bag 1E
2	#0321	Thrust Bearings	Bag 1E
2	#0323	Dampener Rubber O-Rings	Bag 1E
2	#0325	Thrust Bearing Spacer	Bag 1E
2	#0327	Bearing Retainer Washer	Bag 1E
2	#0329	Thin Shim Washer	Bag 1E

##### *Refer to Drawings #1.*

**NOTE:** Prior to beginning this section, be sure to degrease the threads in the #0315 blade axle and bolts #0085 with alcohol or thinner.

- A. Using a pair of needle nose pliers, spread the 10mm piece of fuel tubing #0316 over the #0315 blade axle. Center the fuel tubing on the blade axle and glue in place with slow cyano. **NOTE:** The fuel tubing will be providing the lifting point for the model instead of the #0323 O-rings doing this job. This will allow the O-rings to provide dampening for the model which is what they are designed to do.
- B. Select both #0317 main blade mounts from Step #3. Also select four #0319 ball bearings, one #0321 thrust bearing, one #0325 thrust bearing spacer, one #0327 retainer washer, and one #0085 M5x16 socket head bolt from the parts bag. Press a ball bearing into a blade mount cavity on the control arm end. Seat it fully. Press the second ball bearing into the mount from the fork end. Seat it squarely and fully by using a socket or pipe of suitable diameter (the same O.D. as the bearing) to avoid any pressure on the inner race. Check alignment by sliding the #0315 main blade axle through this bearing, through the mount, and through the previously installed bearing. Remove the axle. Repeat this entire process with the second blade mount.
- C. Carefully slide a #0323 dampener O-ring about 30mm onto the #0315 main blade axle, taking care not to damage it on the sharp edge of the axle. Insert the long end of the axle into the top hole of the head block until the O-ring seats in its annular cavity. Slide the other O-ring on the opposite end of the shaft until it seats in its cavity.
- D. Select the two #0329 shim washers (thin ones) and slide one on each end of the blade axle. Slide a blade mount on one end of the axle. Refer to drawing # 1 for proper orientation.
- E. Lay the #0321 thrust bearing on a clean surface and separate the two races and the ball ring. Note that one race has a larger inside hole diameter than the other. This point is most important. Determine the larger-holed race by slipping each race onto the end of the axle and choose the looser one. Lay the larger race down, ball groove-up, and place the ball ring on it. Apply a small amount of grease and place the other race on the ball ring (groove down). Set aside until you reach Step G.
- F. Slide the #0325 thrust bearing spacer into the fork end of a blade mount up against the ball bearing.

- G. Place a #0327 bearing retainer washer on the M5x16 socket head bolt #0085 and insert the screw down into the thrust bearing from the top. Apply a small amount of Loctite on the threads inside the main axle. Invert the bolt and thrust bearing assembly and, using one of the Allen wrenches in the kit, thread it into the blade axle through the fork end of the assembled blade mount. Tighten most of the way, and slide the blade mount against this stack to square it up. (The thrust bearing should engage the shouldered part of the axle with the small I.D. race nearest the head of the M5x16 bolt).
- H. Repeat steps E, F, and G to install the other main blade mount. Using the two Allen wrenches in the kit, tighten the whole axle assembly firmly. (**IMPORTANT: DO NOT OVER-TIGHTEN** or axle damage may result.) Be sure each blade mount control arm is oriented to the head block as shown in view #1. This is to say that with the right hand rotation of this model, each blade will be commanded by the control arm at its leading edge.
- I. Temporarily install the two M4x45 socket head bolts #0082 and two M4 locknuts #0021 into the blade holders.

**Step 5. Add the Flybar, Control Arms and Head Bolt.**

Parts Required:

1	#0303	Flybar(Inside Tailboom)	Bag 10A
1	#0019	M3 Locknut	1F
2	#0053	M3x5 Set Screws	1F
1	#0091	M3x16(12.9) Head Bolt	1F
2	#0305	Control Arm Spacer	1F
2	#0307	Flybar Control Arm	1F

**Refer to Drawings #1.**

- A. Insert the flybar #0303 into the bearings provided in the #0339 delta offset plates. Follow with one #0305 spacer and one #0307 control arm on each side. Slide each up to the delta offset plates and then center the flybar. Apply loctite and very lightly tighten the M3x5 socket set screw in each control arm until it just touches the flybar. Shift the flybar until there is no side play between the control arms and the flybar is balanced. Now sight from one side at both control arms, align each level with the other. It is helpful to use a small pair of straight edges on each control arm to insure that they are each level to the other. Securely tighten each socket set screw in each control arm. **NOTE:** Available through Miniature Aircraft USA is a special Fly-Bar Alignment Kit. Order #0510.
- B. Temporarily install the main head bolt #0091 and one M3 locknut #0019 into the remaining hole on both sides of the main rotor head block #0289, just below the Delta offset plates #0339. The locknut, inserts into the hex shaped hole. Only slightly tighten the head bolt #0091, at this time.

**Step 6. Assembly of Flybar Paddles**

2	#0561-3	Pro-Paddles Main Section	1A
10	#0561-1	Brass Weight Set Screws	1G
4	#0561-2	Pro-Paddle End Caps (Small and Large)	1G

**Refer to Drawings #1.**



- A. **NOTE:** Before assembling the paddles it will be necessary to choose the over-all paddle weight desired by the number of brass screws used to achieve a desired flying characteristics.

The following characteristic may be expected with the installation of the set screws:

- With no set screws (total weight approximately 14.5 grams) - Crisp response similar to #0311 paddles but without any fore and aft sensitivity in fast flight.
  - With one to four set screws (total weight approximately 16.2 - 20.5 grams) - graduating increase in stability yet still fully acrobatic.
  - With five set screws (total weight approximately 22.0 grams) - excellent smooth hovering and FAI type aerobatics. NOTE: should you wish, it is possible to use a lead strip capped by one set screw to bring the total weight up to about 40.0 grams. Such choices are made considering flying style and total blade weight.
- B. Thread into the front hole on the inner end of each fly-bar paddle #0561-3 the desired number of brass weight set screws #0561-1. Completely install each set screw before installing the next one.
- C. The end caps #0561-2 are simple to install. Set each into position (but not fully flush). Apply a little cyano to the joint and press each end of the paddle onto a flat surface to set the caps flush. Wipe the excess glue away with a paper towel (quickly). Use a light spritz of kicker to quick cure.
- D. Ideally, each paddle should be threaded onto the flybar covering a minimum of 25.0mm. However, should you desire a shorter disc, they may be further threaded to encompass up to a total of 40.0mm of flybar. Be sure to secure threads with slow cyano or epoxy. Align paddles level to each other and in line with the fly-bar control arms #0307. Check drawings for proper orientation. The use of Miniature Aircraft's Fly-Bar Alignment Kit #0510 is very helpful for this step. Final balance of the fly-bar assembly may be achieved by either adjusting the position of one of the brass set screw weights or by trimming the brass weight with wire cutters.

## II. BUILDING TOP MAIN FRAME SECTIONS

### Step 1. Assembly Aileron (Roll) Bellcranks to Main Frames and Mount Tail Push Rod Guides

Parts Required:

1	#0163	Main Frame, Right		Box
1	#0165	Main Frame, Left		Box
2	#0167	Aileron Bellcranks (roll)	Bag#	2A
2	#0169	Aileron Bellcrank Studs (roll)		2A
4	#0159	Ball Bearings M3x7		2A
2	#0171	Aileron Stud Retainer Collars		2A
2	#0105	(M3x4.5) Threaded Balls		2A
2	#0107	(M3x6) Threaded Balls		2A
2	#0051	(M3x3) Socket Set Screws		2A
2	#0019	M3 Locknuts		2A
1	#0387-A	T/R Control Rod Front Guide		2A
1	#0387-B	T/R Control Rod Front Guide		2A
1	#0029	M2.2x13 Phillips Self Tapping Screws		2A

*Refer to Drawings #2.*

- A. Build a left and a right top main frame #0165 & #0163 by installing on the outer side a bellcrank pivot stud #0169 in each frame and a M3 locknut #0019 on the inside of each frame. Tighten securely.
- B. Using slow cyano thread a #0107 M3x6 threaded ball and a #0105 M3x4.5 threaded ball into the flat side of the bellcranks #0167. Do the same thing on the other bellcrank only reversing the position of the balls so that the bellcranks are opposite each other.
- C. Press all four bearings #0159 into the two bellcranks ensuring that they are square and fully seated.
- D. Partially threaded the M3x3 set screws #0051 into the two retaining collars #0171.
- E. Hold the left main frame with its stud facing you, and select the bellcrank which will slide on the stud with one arm vertically down containing a short ball, and the other arm pivoting forward containing a long ball #0107. Place a small amount of Loctite on the set screw threads, partially screw into collar, and retain the bellcrank by sliding the collar on the stud and tighten the set screw. Check to be sure that the bellcrank operates smoothly; if not, slightly back off retaining collar.
- F. Mount the other bellcrank and collar to the right main frame in a similar way. Holding the frames together in normal orientation will show that each has a bellcrank that can be held with an arm pointing forward with a long ball on it.
- G. Install the tailrotor pushrod guides #0387 into the left mainframe using one M2.2x13 Phillips self tapping screws #0029.

**Step 2. Assemble Elevator (Fore and Aft Pitch) Swing Arm Unit.**

**Parts Required:**

2	#0131	Plastic Bearing Bushing	Bag#	2B
1	#0099	Special Bolt M3x30		2B
2	#0155	Elevator Swing Arm Halves		2B
1	#0157	Elevator Bell Crank		2B
1	#0105	M3x4.5 Threaded Ball		2B
2	#0113	M3x10.5 Double Threaded Balls		2B
2	#0159	Ball Bearings M3x7		2B
2	#0161	Pivot Pins Elevator		2B
1	#0019	3mm Locknut		2B
2	#0047	Slotted Checsc Head Machine Screws M2x16		2B
2	#0015	Hex Nuts 2mm		2B
1	#0365	Aluminum Elevator Servo Mount		2B

***Refer to Drawings #2.***

- A. Pick up one Swing Arm Half, #0155, and holding it so that the outside surface of the fork end is against a solid surface, press a Pivot Pin, #0161, into the fork end hole from the inside until its end is flush with the outside surface (bottoms against the supporting surface). Tapping the Pin into place with a mallet or wood block may be necessary. Repeat the process with the other Swing Arm Half.
- B. Press a plastic bearing bushing #0131 into the hole at the opposite end of each Swing Arm Half. Do this from the outside. Slide the special bolt #0099 into each #0131 to check that it pivots freely. Slightly open the holes if needed.

- C. Select the Elevator Bellcrank #0157 from the parts bag, and the Threaded Ball #0105 (single ball end) from the parts bag. Using the proper size Allen Wrench from the tool bag and following the procedure previously described, glue and screw the ball into the arm of the Bellerank.
- D. Following the above procedure, screw in place and glue the two Double End Balls #0113, again referring to the drawing for position.
- E. Select the Ball Bearings #0159 and press them into the remaining holes in the Bellcrank #0157.
- F. Assemble the swing arm halves #0155 to the elevator bellcrank #0157 by squarely pushing the pivot pins #0161 into the ball bearing #0159, aligning and pressing the arm halves together. Secure the halves together with two M2x16 slotted bolts #0047 and M2 hex nut #0015, using Loctite.
- G. Select the right hand main frame plate #0163. As per the drawing insert the special bolt #0099 from the right side through the elevator servo mount #0365 and into the frame plate. Slide the assembled elevator bellcrank assembly onto the special bolt on the inside of the right upper frame side, making sure that the bellcrank arm projects through the aperture in the right side frame with the ball end up. Follow this assembly with the left hand side frame assembly #0165 and one M3 locknut #0019. Do not fully tighten at this time.

**Step 3. Installing Mainshaft Bearing Blocks**

Parts Required:

2	#0182	Main Shaft Lower Bearing Block	2C
4	#0077	M3x30 Socket Head Blocks	2C
4	#0019	M3 Locknuts	2C

*Refer to Drawings #2.*

- A. Install the upper bearing block #0182 (bearing side facing down) in between the two main frames in its respective position using two #0077 M3x30 socket head bolts and two #0019 M3 locknuts. Do not fully tighten.
- B. Install the lower bearing block #0182 (bearing side facing up) using two #0077 M3x30 socket head bolts and two #0019 M3 Locknuts. Do not fully tighten.

**Step 4. Assemble Front Tail Drive Transmission.**

Parts Required:

3	#0051	M3x3 Socket Set Screws	2D
2	#0233	Front Drive Housing Halves	2D
2	#0235	Front Drive Ball Bearings	2D
1	#0237	Front Drive Retainer Collar	2D
2	#0241	Front Drive Housing Guide Sleeves	2D
1	#0231	16 Tooth front Drive Pinion	2D
1	#0239	Front Drive Pinion Shaft	2D
2	#0077	M3x30 Socket Head Cap Screws	2D
4	#0003	Flat Washer M3 (large)	2D
2	#0019	Hex Locknut M3	2D

*Refer to Drawings #2.*



- A. Clean the I.D. of the two bearings #0235 and the front input shaft #0239 with thinner to remove any oil.
- B. **NOTE:** At the builders discretion the bearings and shaft in this section may be glued together using locktite (red, green or blue). If you choose to do this the disassembly process will become very difficult and will require the application of heat to break down the glue.
- Slide one of the bearings #0235 onto the shaft #0239 about half way then apply a small amount of Loctite to your finger and rub it around the shaft up next to the shoulder. Slide the bearing up next to the shoulder. Rub a small amount of Loctite where the other bearing is to be located then slide this bearing into position.
- C. Lay one of the front drive housing halves #0233 on the table and push the output shaft assembly into this half. Put the other half in place and press the two halves together. Start the front transmission sleeves #0241 into the two holes in the drive housing then turn the unit over on the table with the sleeves against the table and push down on the drive housing until the housing is flush against the table.
- D. Apply blue Loctite to one of the M3x3 set screws #0051 and start it in the retainer collar #0237. Slide the collar all the way up against the bearing and tighten the set screw. Ensure that the input shaft is slid completely up against the bearing. Check for binding.
- E. Start the remaining two M3x3 set screws #0051 into the front drive pinion #0231 and position the pinion on the shaft and tighten down one set screw in the flat spot nearest the end just enough to keep the gear on the shaft but at the same time allowing it to slide on the shaft. Final adjustment and tightening will come later.
- F. Bolt the front tail drive transmission into the upper main side frames using two M3x30 bolts #0077, four M3 large washers #0003 and two M3 locknuts #0019 in through the left main frame first. **Do not fully tighten.**

#### Step 5. Install Front Tailboom Support Halves.

Parts Required:

2	#0185	Front Tail Boom Support Halves	2E
4	#0077	M3x30 Socket Head Cap Screws	2E
4	#0019	Hex Locknuts M3	2E

*Refer to Drawings #2.*

**NOTE:** Upper two #0077 bolts must insert through the elevator plate #0365.

- A. Install the tailboom support halves #0185 using four M3x30 bolts #0077, and four M3 locknuts #0019 in through the left main frame first. **Do not fully tighten.**

#### Step 6. Assemble and Install Start Shaft Bearing Block.

Parts Required:

1	#0199	Star Shaft Ball Bearing M6x19	2F
1	#0198	Start Shaft Bearing Block w/Bearing (assembled)	2F
1	#0559-1	Bearing Block Adapter	2F
2	#0077	M3x30 Socket Head Cap Screws	2F

- 4 #0003 Flat Washers 3mm (large)
- 2 #0019 Hex Locknuts M3

*Refer to Drawings #2.*

- A. Assemble clutch shaft bearing block #0198 and bearing block adapter #0559-1. Clean the stepped area in the block and on the bottom of the adapter with alcohol or thinner. Apply a thin coat of Loctite on the adapter base. **Wipe away any excess to avoid bearing contamination.** Position the block on a flat surface (Bearing down) and place the adapter #0559("cup" side up) in place on top of the block #0198. Insert a wooden dowel or appropriately sized socket inside the cup area and tap the adapter into the block until fully inserted.
- B. Apply a very thin coat of Loctite on the outside of M6x19 bearing #0199 and set it onto the adapter cup #0559-1. Use a large socket or block of wood (with a hole as to avoid contact with the bearing inner race). Tap the bearing fully in place.
- C. Install the clutch shaft bearing block using two M3x30 bolts #0077, four M3 large washers #0003 and two M3 locknuts #0019 in through the left main frame first. **NOTE:** The #0559-1 bearing adapter block will be on the top side.

**III. ASSEMBLE OF THE MAINSHAFT COMPONENTS**

**Step 1. Alignment and Tightening of Bearing Block Assemblies.**

Parts Required:

- 1 #0203 Main Shaft 3A

*Refer to Drawings #3.*

- A. Temporarily slide the main shaft #0203 into both main shaft bearing blocks. Lay the bottom edges of the main side frames on a flat surface and tighten the upper and lower main shaft bearing block bolts #0077.
- B. Tighten the M3 locknut on the special bolt #0099. Do not over tighten. The elevator swing arm should pivot freely.
- C. Snugly tighten the start shaft upper bearing block.
- D. Lightly tighten the tail boom support halves.
- E. Remove the main shaft #0203.

**Step 2. Installing the Mainshaft, Autorotation Unit with Maingear.**

Parts Required:

- 1 #0203 Main Shaft 3A
- 1 #0209 Autorotation Hub with Bearing Assembled 3A
- 1 #0207 Main Gear 9:0 to 1 3A
- 2 #0205 Main Shaft Retainer Collars 3B
- 6 #0051 Socket Set Screws M3x3 3B
- 6 #0069 Socket Head Bolts 3B
- 6 #0019 Hex Locknuts 3mm 3B

1	#0211	Plastic Autorotation Hub Spacer	3B
1	#0213	Steel Autorotation Lower Spacer	3B
1	#0215	Retainer Collar	3B

*Refer to Drawings #3.*

**NOTE:** Before installing the mainshaft clean well to remove any residuc.

- A. Slide the mainshaft #0203 down through the top bearing block.
- B. Next place one of the retainer collars #0205 under the bearing block and slide the mainshaft through this.
- C. Next hold the elevator bellcrank #0157 up and slide the mainshaft through this.
- D. Place another mainshaft retainer collar #0205 under the elevator bellcrank and slide the mainshaft through this and the lower bearing block #0182.
- E. Start two M3x3 socket set screws #0051 into each #0205 retainer collars.
- F. Noting that the maingear is two-sided and can be mounted either way, press the gear onto the shorter boss of the autorotation hub, being careful to align the mounting bolt holes. Insert the six M3x16 socket head bolts #0069 from the gear side and secure from the hub side with the six M3 locknuts #0019. Tighten securely. Lightly oil (DO NOT GREASE) the autorotation bearings. (**NOTE:** Tri-Flow Teflon Oil is recommended, order #4801).
- G. Place the plastic auto hub spacer #0211 on top of the main gear and auto hub and then slide the autorotation unit up onto the bottom side of the mainshaft. Follow this assembly with one #0213 lower steel autorotation spacer and one #0215 retainer collar. Secure the retainer collar to the main shaft using two #0051 M3x3 set screws. Tighten securely using loctite.
- H. Place your middle finger on either hand on the bottom of the mainshaft. Place your thumb on the same hand on top of the bottom mainshaft retainer collar and squeeze together. This will pull the mainshaft all the way up and take the vertical play out of the maingear. Tighten up one of the set screws in the collar and then do two things; Spin the main gear while holding the mainshaft to ensure that it spins freely. Next check for vertical play in the main gear by holding it on both sides with both hands and try to move the gear up and down. The ideal situation is where there is virtually no vertical play but at the same time the gear spins freely. Once you are satisfied tighten both set screws in the retainer collar securely.
- I. Apply some blue Loctite to two M3x3 set screws in the upper mainshaft retainer collar #0205. Pull down on the top of the mainshaft with your thumb while pulling up on the upper collar with your middle finger. Tighten both set screws securely.
- J. Remove the M3x3 set screws from the front tailrotor pinion gear #0231 and apply Loctite. Re-install screws but do not tighten.
- K. Push the transmission down into the main gear so that it is seated. Slide the pinion gear back on the shaft till it rubs the step on the maingear then slide the pinion forward about a half of a millimeter then lightly tighten the set screw against the flat. View the gear mesh from underneath the top mainframe. Rotate the maingear 360 degrees and make sure that the pinion gear does not get up against the back edge of the maingear. There should be some clearance all the way around. Once satisfied tighten both set screws securely.



- L. Next adjust the gear mesh between the front transmission and the main gear. You want no play between the gears but no binding or tight spots. If either exists, loosen the mesh slightly. Ensure that the universal joint end of the shaft is pointed straight down the tailboom. To check this find a shaft or drill bit that will fit into the universal joint and check to see if it is centered between the tailboom support halves. Once both of the alignments are done tighten the two M3x30 bolts and re-check alignment. Sometimes it will change slightly when you tighten the bolts.

### Step 3. Assembling Swashplate.

#### Parts Required:

1	#0217	Aluminum Swashplate (10mm)	Bag 3C
4	#0051	M3x3 Set Screws	3C
3	#0107	M3x6 Threaded Steel Balls	3C
4	#0109	M3x8 Threaded Steel Balls	3C
1	#0111	M3x10.5 Thd. Double Ball	3C

#### *Refer to Drawing #3.*

- A. Apply a small amount of Loctite to the four M3x3 set screws #0051 and install them into the outer ring of the swashplate. These set screws are for adjusting the play out of the radial bearing. Lightly tighten up two set screws opposite each other and then check to make sure that the bearing doesn't get notchy. Once these two set screws are set the other two can be set in the same manner.
- B. Examine the swashplate #0217 for control ball positioning. Using a small amount of Loctite on each, thread four M3x8 threaded balls #0109 on the inner ring of the swashplate at 90 degrees apart. Using Loctite mount three M3x6 threaded ball #0107 in three of the four holes in the outer ring of the swashplate. In the remaining fourth hole thread one #0111 M3x10.5 Double Ball.
- C. Slide the swashplate down the main shaft #0203 from the top side.

### Step 4. Assembling Lower Swashplate Control Rods and Anti-Rotation Arm.

#### Parts Required:

10	#0133	Plastic Balls Links Long	Bag 3D
1	#0247	Radius Arm Support	3A
2	#0063	M3x10 Socket Head Bolts	3D
2	#0019	M3 Locknut	3D
1	#0107	M3x6 Threaded Ball	3D
1	#0249	M2x42 Control Rod	3D
4	#0227	M2x42 Control Rods	3D

#### *Refer to Drawing #3 and #11.*

- A. Complete four control rods #0227 by threading a plastic ball link #0133 on each end. The length of the finished rods is determined by laying control rods with ball links attached over the precise full scale view on the control rod length chart. See drawings. The rods must be identical in length. As a check dimension, the length of metal rod between inner plastic link faces is 22.0mm.

- B. Referring to the drawing for control rod placement, snap the ball link on one end of a control rod to the **OUTSIDE** ball on each of the double balls mounted to the elevator bellcrank. Similarly, snap a ball link on the longer of the balls on each roll bellcrank. Holding the four control rods up, snap the four top ball links to the outer swashplate. Be sure the double ball on the swashplate faces to the **LEFT**. The link from the left roll bellcrank should be snapped on the **INNER** ball.
- C. Using two #0063 M3x10 socket head bolts and two #0019 M3 locknuts bolt into position, one #0247 radius arm support onto the top left main frame.
- D. Using slow cyano glue thread the #0107 M3x6 threaded ball in place in the top hole in the #0247 support.
- E. Thread the plastic ball links on the M2x42 control rod #0249 to the length that matches the radius arm rod length in the control arm chart. The reference dimension for the length of the rod between the ball links is 23mm. Snap this rod on the radius arm support ball end and onto the outer (only remaining) ball of the double ball on the swashplate.

**Step 5. Assembling Wash-Out Unit.**

Parts Required:

1	#0219 Wash-Out Center Hub	Bag 3E
2	#0097 Special Bolts M3x22	3E
2	#0109 M3x8 Threaded Steel Balls	3E
2	#0223 Wash-Out Special Links	3E
2	#0221 Wash-Out Arms	3E
4	#0159 M3x7 Ball Bearings	3E
2	#106-07 Pivot Pins	3E
5	#106-08 Circlips	3E

***Refer to Drawing #3.***

**NOTE:** One extra #106-08 circlip is included.

- A. Take the two washout control arms #0221 and the two M3x8 Balls #0109 (longer shank) and thread a ball into the hole in the long end of each Arm from the flat side. Use Slow Cyano. Make sure the balls are threaded squarely in place and lightly seated against their flanges.
- B. Press Ball Bearings #0159 into both sides of the center holes in both Control Arms.
- C. Using two special washout arm bolts #0097, and carefully follow the drawing , screw the arms on the washout center hub #0219. (Suggestion: squarely start the thread of each bolt into its hole in the hub part way first without the arm.) The control ball should face inward. Tighten entire assembly until there is no lateral play and no bearing drag.
- D. Using two pivot pins #106-07 assemble the wash-out special link #0223 to each control arm #0221. Their orientation is shown on the drawing. Note that they mount on the short end of the arms, projecting inward. The pins press in place centered in the links. Secure each end of the pins using circlips #106-08. The special links #0223 should have no end play and pivot freely. If they do not pivot freely, carefully apply heat with a heat gun until they operate smoothly.

- E. Slide assembled wash-out unit down onto the mainshaft, snap the two #0223 wash-out links onto any two opposite #0109 steel balls on the inner ring of the swashplate.

#### IV. ASSEMBLE OF FRONT FRAME SECTIONS

##### Step 1. Assembly of Front Vertical Frame and Tank Support.

###### Parts Required:

1	#0175	Front Frame Support Plate	Bag 4A
1	#0189	Tank Support Tray	4A
1	#0179	Canopy Latch Plate	4B
2	#0245	Lower Canopy Support Studs	4B
2	#0065	M3x12 Socket Head Cap Screws	4C
18	#0063	M3x10 Socket Head Cap Screws	4C
12	#0019	3mm Hex Locknuts	4C
8	#0003	Flat Washers 3mm (large)	4C
1	#0191	Motor Mount	4D

###### *Refer to Drawings #4.*

- A. Install the motor mount into the lower section of the main frame assembly using six M3x10 socket head bolts #0063 and six M3 washers #0003. This is only a temporary installation of the motor mount for frame alignment. Four of the #0063 bolts will be replaced with #0065 bolts in Section VI.
- B. Place the frame assembly on a flat surface and, ensuring that both frame bottom flanges rest solidly on the surface, generally "square up" the entire unit and snugly tighten the motor mount bolts.
- C. Mount the front support plate #0175 to the front side of both main frames using six #0063 M3x10 socket head bolts, two #0065 M3x12 socket bolts, and eight #0019 M3 locknuts. Use the #0065 M3x12 bolts to mount the canopy latch plate #0179 against the upper front face, two holes of the front support plate #0175. Tighten all bolts and nuts securely.
- D. Mount the two lower canopy support studs to the forward holes in the sides of the tank support tray using two M3x10 socket head bolts. Use Loctite. Tighten securely. Cut two 12mm lengths of fuel tubing (supplied with tank) and press them fully on the ends of the studs. These will provide resilient canopy mounting.
- E. Mount the tank support tray #0189 in position under the front support plate #0175, using four #0063 M3x10 socket head bolts and four #0019 M3 locknuts. Tighten securely.

#### V. INSTALLING ENGINE AND FAN SHROUD ASSEMBLIES

##### Step 1. Mounting Flywheel.

###### Parts Required:

1	#0546-17	Cooling Fan (Assembled)	Bag 5A
1	#0546-21	Fan Assembling Tool	5A
4	#0546-16	Urethane Dampeners	5B
1	#0546-5	Upper Fan Drive Collet (O.S. SX)	5B
1	#0331	M13x.5 Flat Steel Washer	5B

1	#0007	M6.6x12.3 Flat Steel Washer	5B
1	#0546-6	Lower Fan Drive Collet	5B
1	#0546-8	Upper Fan Drive Collet (O.S. SFN)	5B

**NOTE:** - This kit includes only (O.S. 61) collet pack. You must purchase separately the appropriate "Collet Pack" containing all hardware for any other specific engine.

**Collet Pack**

**Engine Application**

0546-4 - Included in kit -	O.S. .61SX-H, RX-H
0546-7 - Included in kit -	O.S. .61SFN-H, FRN-H
0546-9 - (Opt.)	ENYA 60XF, XLF
0546-11 - (Opt.)	Y.S 61FSH, FRH
0546-14 - (Opt.)	Webra 61H (X-Cell/Schluter type with 9.5mm O.D. solid crankshaft) and 50 H.
0546-15 - (Opt.)	Webra 61, Pico, Rossi and O.P.S. with special "Heim" type 8.0mm O.D. solid crankshaft.
0546-22 - (Opt.)	Super Tigre .61-H (with 1/4" crankshaft threads)

**Webra Note:** Most Webra Heli engines fall into one of three crankshaft categories:

- Those with 9.5mm O.D. crankshaft previously having a factory fan/hub assembly.
- Those with 8.0mm O.D. crankshaft designed for use in Graupner/Heim or Robbc Magic/Futura Heli's. Use **Collet Pack #0546-15**.
- Those with 1/4" O.D. Stepped crankshaft similar to O.S. 61 SFN-H. This configuration will use **Collet Pack #0546-7** with minor modification.

***Refer to Drawings #5.***

- A. Although not essential, it is suggested that the engine to be used receive a suitable break-in run prior to installation. Set the throttle barrel stop to allow full carburetor shut off at the low end and retain (or record) the idle and high speed mixture needle settings. These are more easily done on a test bench.
- B. The precise centering of the fan assembly is achieved by the use of special collets provided in the Custom kits. This will fit the majority of engines commonly selected for helicopter use. Measure the shaft diameter of your engine and if it differs, contact your dealer or Miniature Aircraft USA direct to obtain the correct collet pack. This is essential for a true running engine/shaft assembly and a vibration-free helicopter! (Radio and servos live short, unhappy lives in high vibration applications!)
- C. For all engines factory equipped with thrust drive washers, collet and/or keys, remove them. Webra engines previously equipped with cooling fans should have them removed along with the drive keys. O.S. 61 SX and SFN-H series engines utilize a 1.0mm thick spacer washer between the thrust washer and front bearing which must be left in place for our use. Some Super Tigre .61-H engine may have a similar washer beneath the thrust drive washer. Be sure you have only (1) washer in place between the front bearing and base collet.
- D. A few types of engines will require slight shortening of the crankshaft threads. Use the following guidelines:

Engines not requiring shortening:

O.S. 61 SX/RX  
O.S. 61 SFN-H/RFN-H  
Y.S. 61 FSH/RSH  
Webra 50 heli  
Super Tigre .61 H (1/4" crank type)

Engines requiring shortening:

Enya 60 XF-----Cut 4.0mm - Approx.  
Webra 61 H (9.5mm crank X-Cell/Schluter Type)----- Cut 2.0mm - Approx.  
Webra 61 H (Pico, O.P.S., Rossi, (8mm crank Heim type)----- Cut 4.0mm - Approx.

The best procedure for cutting the crank threads without damage is to install the crank nut below the cut area, make the cut with a Dremel tool and carbide disc. Chamber the edge with a file, and "chase" the threads by un-threading the nut. Be sure to thoroughly shield the engine against metal particles.

**NOTE:** Some engines such as O.S. 61SX and Y.S. 61 will require a "thin-wall" type socket to tighten the crank nut.

- E. To ensure concentricity, only use the proper **Collets** for your engine. Similarly, do not make any substitution for any special spacers or hardware.  
**Important:** - In any installation, be certain that the crankshaft does not extend above the top surface of the fan hub. Select the correct instruction steps for your particular engine.
- F. Use the following guides for installing the fan and the collet packs.

**1. O.S. 61 SX-H/RX-H (Collet Pack #0546-4).**

- Install the large I.D. (9.5mm) base collet #0546-6(with the tapered side upward away from the engine) into position against the factory 1.0mm thick front bearing spacer washer.
- Slide fan hub assembly #0546-17 onto the base collet.
- Insert the upper collet #0546-5 (8.0mm I.D.) with the tapered side facing down in the fan hub. **NOTE:** This collet has a 9.52mm I.D. step for crankshaft clearance.
- Follow with the #0331(M13.0x8.0x.5) flat washer. Apply a little Loctite to the factory nut and install and tighten firmly.

**2. O.S. 61 SFN-H/RFN-H (Collet Pack #0546-7).**

- Install the large I.D. (9.5mm) base collet #0546-7(with the tapered side upward away from the front bearing) into position against the factory bearing spacer washer.
- Slide fan hub assembly #0546-17 onto the base collet.
- Insert the upper collet #0546-8 (6.23mm I.D.) with the tapered side and internal step facing downward into the hub.
- Follow with flat washer #0007 (M11.75x6.5x1.7). Apply a little Loctite to the factory nut and install and tighten firmly.

**3. Enya 60 XF/XLF (Collet Pack #0546-9).**

- Install one #0325 flat washer (M16.0x10.0x1.0) onto the crankshaft up against the front engine bearing.
- Install the large I.D. (9.5mm) base collet #0546-6(with the tapered side upward away from the front bearing) into position against the #0325 washer.
- Slide fan hub assembly #0546-17 onto the base collet.
- Insert the upper collet #0546-10 (7.0mm I.D.) with the tapered side facing down in the hub.
- Follow with the #0005(M11.75x6.5x1.7) flat washer. Apply a little Loctite to the factory nut and install and tighten firmly.

**4. Y.S. 61 FSH/FRH(Collet Pack #0546-11).**

- Install spacer adapter #0546-13 onto the crankshaft with the "Double Stepped" side facing and contacting the front engine bearing.
- Install the large I.D. (9.5mm) base collet #0546-6(with the tapered side upward away from the engine) into position against the #0546-13 spacer/adapter.
- Slide fan hub assembly #0546-17 onto the base collet.
- Insert upper collet #0546-12 (with the tapered side downward into the hub).
- Follow with #0331 flat washer(M13.0x8.0x.5). Apply a little Loctite to the factory nut and install and tighten firmly.

**5. Webra 61 Heli (X-Cell/Schluter type with 9.5mm solid crankshaft) - (Collet Pack #0546-14).**

- Install #0325 flat washer (M16.0x10.0x1.0) onto the crankshaft up against the front engine bearing.
- Install spacer/adapter #0546-13 onto the crankshaft with the "Double Stepped" side facing and contacting the previously installed #0325 flat washer.
- Both collets in this application are the same #0546-6. Install one(tapered side away from the engine) up against the spacer/adapter #0546-13.
- Slide fan hub assembly #0546-17 onto the base collet.
- Insert the remaining #0546-6 collet (tapered side downward) into the fan hub.
- Follow with #0005 flat washer (M11.75x6.5x1.7). Apply a little Loctite to the factory nut and install and tighten firmly.

**6. Webra 50 Heli (X-Cell/Schluter type with 9.5mm solid crankshaft) - (Collet Pack #0546-14).**

- Follow same steps as in webra .61 above except that the #0325 (M16x10x1.0) flat washer next to the front bearing is eliminated.

**7. Webra 61 H, Pico, O.P.S. and Rossi, special O.S. .61 HG (Heim type with 8.0mm solid crankshaft) - (Collet Pack #0546-15).**

- Install #0331 (M13.0x8.0x.5) washer onto the crankshaft up against the front engine bearing.
- Install #0546-20 spacer on top of the 0331 washer. Follow with (1) #0546-5 collet with the tapered side away from the engine.
- Slide fan hub assembly #0546-17 onto the first collet.
- Insert the remaining #0546-6 collet (tapered side downward) into the fan hub.
- Follow with (2) #0007 flat washers (M11.75x6.5x1.7). Apply a little Loctite to the factory nut and install and tighten firmly.

**8. Super Tigre .61-H (with 1/4" crankshaft)  
Pack #0546-22.**

- Install one #0325 flat washer (M16.0x10.0x1.0) onto the crankshaft. Disregard if your engine was previously equipped with a similar washer next to the bearing.
- Install the large I.D. (9.5mm) base collet #0546-6(with the tapered side upward away from the engine) into position against the factory 1.0mm thick front bearing spacer washer.
- Slide fan hub assembly #0546-17 onto the base collet.
- Insert the upper collet #0546-5 (8.0mm I.D.) with the tapered side facing down in the fan hub. **NOTE:** This collet has a 9.52mm I.D. step for crankshaft clearance.
- Follow with the #0331(M13.0x8.0x.5) flat washer. Apply a little Loctite to the factory nut and install and tighten firmly.

Following your appropriate collet pack and prior to inserting the urethane dampener, use the fan tool provided to hold the fan hub securely for crank nut tightening. The tool has studs that will fit into opposite corners of the fan hub cut-outs.

- G.** Select the (4) urethane dampeners #0546-16. Grip a dampener firmly with a pair of pliers (with about 1/3 exposed below) and insert one fully into each cavity provided as shown. Using a slight rocking motion to start it into the hole provided. Once started, use a tool (or tabletop) to press the urethane fully into



the hole. They should not protrude past the top surface of the hub when properly installed. If they do, trim the excess flush with the hub using a single-sided razor blade.

**TIP:** If the urethane is too difficult to press into position, firmly squeeze it with flat pliers and then try the installation again. This will change its O.D. temporarily to ease insertion.

### Step 2. Installation of Clutch Assembly and Align Engine.

Parts Required:

1	#0285	Aluminum Start Cone	Bag 5C
1	#0273	Clutch Spacer Washer	5C
1	#0275	Clutch Bell w/Bearings, Pinion, Liner(Assembled)	5C
1	#0546-1	Clutch Assembly	5C
2	#0053	M3x5 Socket Head Set Screws	5C
1	#0558	(Previously installed in frames from Section 2, step 6)	

*Refer to Drawing #5.*

**IMPORTANT:** For this system to function properly it is essential that:

- A. The clutch /bell assembly "hang" from the start shaft bearing block with a minimum of .10mm (.004) to a maximum of .2mm (.010") vertical end play prior to engine installation. This is accomplished by adjusting the height of the start cone or uni-lock adapter on the start shaft against the upper bearing. If additional height is desired for fuselage or similar application, a spacer must be added between the start adapter and the upper bearing.
- B. Remove the previously installed double bearing block #0558 in the main frames.
- C. Stack the spacer washer #0273, the clutch bell #0275, and the double bearing block #0558 (circular side facing upward), onto the pre-assembled centrifugal clutch #0546-1. Slide the assembly up into position within the main frames and install the aluminum start cone #0285 using two #0053 M3x5 socket set screws. Adjust the assembly until the proper end play is achieved. Secure the two #0053 set screws with Loctite. Once this is done, install the bearing block bolts #0077, washers #0003, and locknuts #0019 and make a preliminary gear mesh setting.

When aligning the pinion to the main gear #0207, two things must line up. First the two gears should have a little play between them throughout the entire rotation of the main gear and the pinion gear must be at 90 degrees to the main gear. The latter can best be achieved by using a small bubble level that is easily obtainable at most hardware stores. Place the level on the outer ring of the main gear and level the mechanics, then place the bubble on the clutch bell. Once these two requirements are met, securely tighten the two M3x30 bolts.

**NOTE:** It is helpful to position the block as low as the bolt/holes will allow, as in long term use, if any shifting occurs (from engine wear or loosening bolts) that there will still be some slight adjustment available to you without moving the motor mount.

### Step 3. Installing the Engine and Fan Shroud Braces.

Parts Required:

4	#0080	M4x14 Socket Head Bolts	Bag 5D
4	#0065	M3x12 Socket Head Bolts	5D
1	#0549-6	Fan Shroud Brace (Right)	5D

1	#0549-7	Fan Shroud Brace (Left)	5D
1	#0546-19	Alignment Tool	5D

*Refer to Drawing #5.*

- A. Remove the previously installed motor mount #0191 from within the main frames. Only two of the #0063 bolts and all of the washer #0003 will be used.
- B. The motor mount can be flipped over if necessary to vary its height in the mainframes. If you are using an O.S. engine the two holes next to each other will be on the top side of the motor mount.
- C. Mount the motor mount #0191 to the engine using four M4x14 socket head bolts #0080 with Loctite. Tighten the bolts enough to hold the engine against the motor mount, yet still allowing you to slightly move the engine from side to side.
- D. Slide the engine up into the frames and engage the Delrin ball and the drive pins on the bottom of the clutch into the Delrin isolators in the top of the flywheel. **Do not fully seat.**
- E. Take the alignment tool #0546-19 and slide it between the top of the flywheel and the bottom of the clutch. Notice that it has a notch in the cutout area near the handle portion. This is for clearance for one of the drive pins.
- F. Once the tool is in position temporarily secure the motor mount with one socket bolt M3x10 - #0063 and flat washer M3 #0003 in the further most rear hole of the motor mount on each side. Select both pieces of the fan shroud brace #0549-6 (right) and #0549-7 (left). The left hand version mounts via the uppermost and lowermost motor mount bolts through the 4.75mm and 3.0mm holes in the braces. When installed, the left hand version sweeps forward and inward at the top. The 4.75mm hole at the bottom allows fore and aft adjustment, while the slot at the top allows up/down fan shroud adjustment. The right hand version is the opposite. Use two M3x12 socket head bolts #0065 with the M3 large flat washers #0003 at the lower end of the brace (into the motor mount). It is best to use the rearmost motor mount bolt on each side to hold the motor and alignment while adjusting the fan shroud braces for proper fan clearance. Use Loctite on all motor mount bolts.
- G. Push upward on the engine assembly while firmly holding the start shaft with downward pressure so that all components are snug against the alignment tool. Once in place, check to see that the start shaft still loaded downward ensuring that the clutch bell end-play is still evident. Visually inspect the installation. (**Tip:** It is most helpful in alignment of this and other aspects of helicopter assembly to obtain very small bubble level to aid in alignment. If you cannot locate such items contact Miniature Aircraft USA for a source). The engine/clutch should be level and evenly contacting the alignment tool as viewed from all angles. Alternately tighten all motor mount/engine bolts and remove the alignment tool. Re-check for proper gear mesh and clutch bell end play.
- H. Install the carburetor at this time.

**Step 4. Installing The Fan Shroud Assembly.**

Parts Required:

1	#0548-5	Fan Shroud (left and right)	Bag 5A
5	#0029	M2.2x13 Phillips Screws	5E
4	#0061	M3x8 Socket Head Cap Screws	5E
2	#0009	Flat Washers M3 small	5E

*Refer to Drawing #5.*

**NOTE:** Generally, the rear fan shroud mounting boss will tolerate any re-positioning of the fan shroud to accommodate the various gear ratios. If, for some reason, you would like to move the rear of the shroud also, there is extra plastic molded behind the bolt holes on each side to allow for the drilling of new holes. However, this is usually not necessary.

- A. Install both halves of the fan shroud #0548-5 into position and then screw the halves together using five, M2.2x13 Phillips screws #0029 from the right side.
- B. Place two M3 small washer #0009 on two M3x10 socket head bolt #0061 and thread them into the front fan shroud mounting holes through each upper hole in the fan shroud braces. Use a small amount of slow cyano on each bolt. Do not tighten completely.
- C. Screw an M3x8 bolts #0061 into the fan shroud lower mounts on each side. Use slow cyano.
- D. Align the final shroud so that it is square to the fan and then tighten all previously installed hardware. Check for no binding when engine is rotated. It may be necessary to loosen the four bolts #0065 holding the front fan shroud braces and re-adjust for proper fan clearance.

**NOTE:** It is possible to R & R the engine/motor mount assembly without disturbing the clutch/bell assembly or the gear mesh if your careful. You will find service, in this regard, to be far simpler than with the conventional system.

**"Fan Removal for R & R"**

Removal of the fan hub from the engine is quite simple. Support the fan/hub assembly from beneath as near to the engine as possible. Un-thread the crank nut until it is even with or slightly above the ends of the crankshaft. Tap the nut/crank with a wooden dowel and hammer or the plastic handle of a tool. The upper collet should release easily, unless you have used excessive amounts of Loctite. If this is the case apply a little solvent such as acetone or thinner to the upper collet to help loosen the Loctite.

**VI. INSTALLATION OF LANDING GEAR ASSEMBLY**

**Step 1. Assemble Landing Gear and Install.**

Parts Required:

2	#0153	Skids	Bag 6A
2	#0151	Struts	6A
4	#0019	M3 Locknuts	6B
4	#0071	M3x18 Socket Head Bolts	6B
2	#0177	Main Frame Strut Plates	6B

***Refer to Drawing #6.***

Special Tool Required: Heat gun (Monokote type) or a source of heat such as boiling water.

- A. Examine view on the drawing to determine orientation of the struts #0151 and skids #0153. Note that the struts sweep forward.
- B. Wearing a glove or using a cloth for protection from heat, pick up one flexible strut and, with a skid conveniently at hand, heat one end of the strut until the skid can be pushed into the hole from the front without undue pressure. **Do not overheat!** Push the skid through until its end projects rearward through the strut exactly 227mm.

- C. Pick up the second strut, heat it the same way and press it on the skid until the skid projects rearward from it exactly 62mm. Again check drawings for orientation. The distance between the bolt holes from the front to the rear strut should be 165mm.
- D. Grasp the forward strut again, heat its opposite end and, in a similar fashion, press the second skid through this hole. Continue until it is about to engage the second strut. Now heat the rear strut and, before the front one cools, slide the skid through both into its final position.
- E. Install the landing gear with two landing gear braces #0177 between the landing gear and the lower aluminum frame #0163 and #0165. Use the four M3x18 bolts #0071 and M3 locknuts #0019.

## VII. RADIO TRAY ASSEMBLE AND SERVO INSTALLATION

### Step 1. Installation of Radio Tray Frame Supports.

#### Parts Required:

1	#0349-L	Lower Tray Frame Support (left)	Bag 7B
1	#0349-R	Lower Tray Frame Support (right)	7B
1	#0347	Upper Tray Frame Support	7B
2	#0063	M3x10 Hex Head Bolts	7B
4	#0019	Hex Locknuts 3mm	7B
2	#0089	M3x10 Hex Head Bolts	7B

#### *Refer to Drawing #7.*

- A. Identify the placement of the upper #0347 and lower #0349 L + R radio tray frame supports on the drawing.
- B. Mount the upper tray frame support #0347 to the vertical front plate #0175 using two M3x10 socket head cap screws #0063, and two locknuts M3 #0019. Only assemble loosely at this time.
- C. Mount the lower tray frame support #0349-1 (left) and #0349-2 (right) using two M3x10 hex head bolts #0089, and two locknuts 3mm #0019. To the front side of the vertical front plate #0175. The two #0089 bolts are installed from the inside out on the #0175 for clearance of the fan shroud. Do not tighten completely.

### Step 2. Mount Servo's into Plastic Tray Components and Assemble Plastic Tray.

#### Parts Required:

2	#0029	M2.2x13 Phillips Tapping Screws	Bag 7C
13	#0027	M2.2x9.5 Phillips Tapping Screws	7C
8	#0001	Flat Washers 2mm (small)	7C
2	#0575-3	Servo Spacer Blocks w/Three Holes	7C
4	#0575-1	Servo Screw Doubler Blocks w/Two Holes	7C
4	#0035	M2.2x16 Phillips Tapping Screws	7C
1	#0575-4	Upper Servo Tray	7A
1	#0575-5	Lower Servo Tray	7A
1	#0575-6	Main Vertical Support and Throttle Mount	7A
2	#0351	Roll Servo Pivots (male)	7C
2	#0353	Roll Servo Pivots (female)	7C
2	#0357	Plastic Pivot Bushings	7C

1	#0575-7	Secondary Vertical Brace "H"	7A
1	#0575-8	Switch Plate	7A

**Refer to Drawing #7.**

- A. Examine exploded view showing the placement of plastic parts and servo in the Radio Tray servo placement. Examine the #0575-5 Lower Tray. You will see that long, thin slots are molded in the front and rear of this part. It is necessary to cut through the slots at the rear of the lower tray thus removing the last 20.0mm Lower Support Brackets.
- B. **Servo Installation:** The order of assembly of the various plastic parts is not critical; however, experience has shown that it is more convenient to initially fit the servos prior to overall assembly. The reason for this is due to the adjustable nature of servo openings. Obviously this tray must accept all popular servo sizes, so the following will outline each servo installation.

**Mount Servo's as Follows:**

1. **Roll (Aileron) Servo:** Note that the aileron (roll) servo is mounted on pivots to allow it to rock fore and aft under control of the collective pitch servo ahead of it. Select the servo to be used for Roll control and install all four rubber grommets. Select a #0351 Roll Servo Pivot from the parts bag and, holding it in place under one end, use a small drill to mark it for proper hole drilling to accept two of the servo mounting screws from your radio hardware. (**NOTE:** Recognize that screwing this servo to the Pivot is just like screwing the servo down to a wood or plastic servo tray in that a small enough drill must be selected to allow your particular screws to thread into the plastic.) Drill the holes and screw the Pivot to the servo. In identical fashion, mount the remaining #0351 Pivot to the other end of the servo. Press two #0357 plastic pivot bushings into the holes in the two #0353 Roll Servo Pivots. Hold the servo in approximate position centered in its clearance hole in the tray and press the bushings of the Pivot Supports into the servo Pivot ends (lightly grease). **NOTE:** The servo should pivot freely. Slightly enlarge pivot bushing holes if needed.

Rotate each #0353 servo pivot into their respective position on the underside of the upper tray #0575-4. Hold the entire servo assembly and the upper tray together. Allow no side play in the servo and center the output spline with the true center of the tray (the rear hole of the screw to the vertical support #0575-6 is true center). Lightly cyano glue the pivot supports #0353. Re-check the servo alignment, good retention end-wise and freedom to pivot. Glue securely. From the top side of the upper tray drill two small holes through the slots provided into the servo pivots #0353. Secure using four #0027 (M2.2x9.5) self-tapping screws and four M2 washers #0001.

2. **Rudder Servo:** Select two plastic spacer blocks #0575-3. Using the original servo hardware, mount the blocks to the servo allowing at least 1.0mm of servo case clearance. Set the assembly into position in the tray. The output position of the servo is to the rear of the tray. Align the center hole on each block #0575-4 install a #0027 M2.2x9.5 Phillips Screw into each center hole. Center the servo within the opening and tighten all four servo screws previously installed. Apply a thin coat of cyano around each block #0575-3.

3. **Collective Servo:** Mount the collective servo with the splined output shaft towards the rear. Secure servo using the four servo screws provided in the radio system and two doubler blocks #0575-1.

4. **Throttle Servo:** Select the vertical tray support #0575-6. Mount the throttle servo with the splined output shaft towards the rear. Secure servo using four #0035 (M2.2x16) Phillips tapping screws, four #0001 (M2) washers, and two #0575-1 doublers. Cyano doublers from the back side.

C. **Overall Assembly:** Refer to **View** for overall positioning of all plastic parts. It is best if a thin line of cyano is put on the mating surfaces prior to installation of the screws. Using two #0027

(M2.2x9.5) Phillips self-tapping screws, fasten the vertical tray #0575-6 to the underside of the upper tray #0575-4. Secure the secondary vertical brace #0575-7 ("H" shaped) to the front side of the vertical tray #0575-6 using one #0027 M2.2x9.5) screw. Mount the vertical brace with the screw eyelets pointing forward (towards the helicopter's nose). Position the main lower plate #0575-5 and secure using two #0029 (M2.2x13) Phillips tapping screws through the front two holes in the upper servo plate #0575-4. Use two #0027 (M2.2x9.5) in the center two holes on the bottom side.

**Step 3. Mount Plastic Tray to Main Frames and add Front Brace.**

**Parts Required:**

2	#0560-8	Flat Washers M2.5	Bag 7D
4	#0061	M3x8 Socket Head Cap Screws	7D
2	#0009	Flat Washers M3 small	7D
4	#0003	Flat Washers M3 large	7D
8	#0019	Servo Screw Doubler Blocks w/Two Holes	7D
4	#0065	M3x12 Socket Head Cap Screws	7D
2	#0578-1	Aluminum Servo Tray Brackets	7A
2	#0029	2.2x13 Phillips Tapping Screws	7D

**Refer to Drawing #7.**

- A. Push the tray up against the frame vertical front plate #0175, and the upper tray support #0347, assemble loosely in place using two M3x12 socket head cap screws #0065, two flat washers M3 small #0009, and two hex locknuts M3 #0019. As previously mentioned for .50/.60 installation, the lower tray was trimmed for clearance of the lower metal brackets #0349. In this installation, utilize the (2) 3.0mm holes lowest in the tray with two #0065 (M3x12) socket head bolts and two #0019 M3 locknuts.
- B. Install one aluminum servo tray bracket #0578-1 in the direction shown in the remaining two holes on the bottom side of the lower servo tray #0575-5 using two flat washers M2.5 #0560-8 and two Phillips tapping screws M2.2x23 #0029. Do not fully tighten at this point.
- C. Install the remaining #0578-1 vertical brace as shown on the tank tray, using two #0061 M3x8 socket bolts and two #0019 M3 locknuts (leaving them only slightly tight for future adjustment).
- D. Install two #0061 M3x8 socket bolts with two #0003 flat washers through both vertical braces at the center followed by two #0003 washers and two #0019 M3 locknuts. Draw them up but do not fully tighten.
- E. With everything generally in alignment, tighten the phillips screw first - then the M3x8 bolts in the tank tray.
- F. Final tightening of the upper and lower tray supports and the center bolts in the #0578 vertical brace will be completed after installation on the fuel tank.

**Step 4. Mount Elevator Servo.**

**Parts Required:**

4	#0560-2	Phillips Machine Screws (M2.5x14)	7E
4	#0560-3	Brass Hex Nuts M2.5	7E
4	#0560-4	Lock Washer M2.5	7E



8	#0560-8	Flat Washers M2.5	7E
3	#0389	Electrical Wire Lead Retainer	7E
1	#0063	M3x10 Socket Head Bolt	7E
1	#0019	M3 Locknut	7E

*Refer to Drawing #7.*

- A. Check servo clearance in the cutout #0365 elevator plate and increase if necessary. Install all four rubber grommets and brass eyelets into the elevator servo provided in your radio system. Drill four holes in the elevator plate #0365 to match the servo mounting holes. The hole drilled will need to be slightly larger than the 2.5mm bolts provided. Mount the servo with the out put position towards the front in the following order using four M2.5x14 Phillips machine screws #0560-2, four M2.5 flat washers #0560-8, the elevator plate #0365, the servo. Four more M2.5 flat washers #0560-8, four M2.5 lock washers #0560-4, and four M2.5 brass hex nuts #0560-3. Snugly tighten using blue Loctite.
- B. Route the servo wire towards the front radio tray using the three electrical wire lead retainers #0389 provided. The retainers are used by pressing them onto the head on a 3mm bolt. A suggested wire route is to use the forward top bolt holding the tail boom support halves #0185, to the back bolt holding lower main shaft bearing block #0182 to the back bolt holding the start shaft bearing block #0198.
- C. Install one #0063 M3x10 socket head bolt into the remaining hole in the elevator plate #0365. Secure from the inside with one #0019 M3 locknut. Tighten securely.

### VIII. INSTALLING FUEL TANK SYSTEM

#### Step 1. Assembling Fuel Tank System.

Parts Required:

1	#0395	Fuel Tank	Bag 8
1	#0397	Fuel Line	8
1	#0401	Fuel Clunk	8
2	#0011	Fuel Fitting Washers	8
2	#0013	Fuel Fitting Nuts 5mm	8
1	#0403	Fuel Pick-up	8
1	#0405	Fuel Vent	8

*Refer to Drawing #8.*

- A. As per the drawing mark where the fuel fittings are to be installed.
- B. Use a #13 or a .185 drill bit to drill the holes for the fuel fittings. If the drill bit doesn't make a clean hole, use a sharp X-acto knife to clean up the holes.
- C. Install the fuel pressure fitting #0405 from inside the tank followed by a fuel fitting washer #0011 then a hex nut #0013. Tighten the nut securely to prevent leakage.
- D. Install the fuel line fitting #0403 in the tank from the inside. The threaded portion of the fitting should be on the outside on the tank. Place a washer and a hex nut on the fitting and tighten securely.

- E. Cut a piece of fuel line (#0397) 86mm long. Push the fuel line up onto the fuel line clunk #0401 then using a long pair of hemostats slide the fuel line onto the fuel line fitting. Next hold the tank and rotate it and watch what the clunk does. It should rotate or flop freely about the tank and not be allowed to go all the way into a corner. This may cause it to suck up against a side while the engine is running and cause fuel starvation and possible failure.
- F. Use double sided servo tape to secure the fuel tank to the top side of the tank support tray #0189. Center the tank in between the lower canopy stand-offs #0245.
- G. At this time tighten all remaining bolts not tighten on the servo tray assembly from section VII, step 3-D.

IX. **ASSEMBLE THE TAILROTOR TRANSMISSION**

Step 1. **Assemble Tailrotor Hub and Blade Holders.**

Parts Required:

2	#0463	Tail Rotor Blades	9A
4	#0019	Hex Locknuts 3mm	9A
2	#0073	M3x20 Socket Head Bolts	9A
2	#0103	M2x5 Threaded Steel Balls (Long Thread)	9A
2	#0299	M4x10 Ball Bearings	9A
2	#0453	Tail Rotor Blade Mounts	9A
2	#0457	T/R Thrust Bearings	9A
4	#0446-3	Special Shims .001	9A
4	#0446-4	Special Shims .003	9A
1	#0446-1	One-Piece Machined 4mm Stud Steel Tail Rotor Hub	9A

*Refer to Drawing #9.*

**NOTE:** Remember to clean all steel components before applying Loctite.

- A. Take the two tailrotor blade mounts #0453 and thread the M2x5 threaded balls #0103 into the outboard holes, using slow cyano.
- B. Press the M4x10 ball bearing #0299 into the blade mounts, on the root end, seating them squarely and fully.
- C. Lay out the two thrust bearing assemblies #0457. Use two spare 4mm bolts for greasing and assembling the thrust bearings. Each bearing has one race that has a smaller I.D. Place the small I.D. halves on the two bolts with the ball groove facing up. Apply grease all the way around the groove. Next place the ball retainers with the cup sides up onto the balls. Apply grease to the top sides of the bearing race that has a larger I.D.. Place the other halves of the bearings on the bolts completing the assemblies, wipe off any excess grease.
- D. Slide the blade holders onto the one piece machined steel T/R hub #0446-1 followed by the thrust bearings. **NOTE:** The large I.D. half of the thrust bearings has to go on the steel hub first, leaving the small I.D. half next to the shims #0446-3 or #0446-4.
- E. Thread the #0019 M3 locknuts up onto the steel hub and lightly tighten. Check for end play in the blade holders. **NOTE:** If there is end play in the blade holders it will have **NO** adverse effect on the operation of the tailrotor due to centrifugal force loading the thrust bearing as it was designed to do. However two different sizes of shims are provided if you would like to remove

some of the end play. **NOTE:** A small amount of end play must exist so as not to put the bearing in a bind. If shims are used, place an equal amount on each side because it is important to keep the distance equal between the center of the hub and each blade pivot hole.

- F. Insert into each blade holder #0453 one tail rotor blade #0463 followed by one M3x20 socket head bolt #0073. The tail rotor pivot bolts #0073 should be facing inward. Secure using one #0019 3mm locknut. Tighten only enough that the tail blade can rotate with slight pressure. **NOTE:** If the tail blade and mount are held horizontally the tail blade will not fall.

**NOTE:** Re-check drawing for correct tail blade directional orientation for a clockwise rotation.

**Repeat entire procedure for the other tail blade.**

- G. To balance the entire tail rotor assembly the #0429 tail rotor output shaft found in section 9C may be used as a balance bar. Lightly grease the output shaft and slide the #0449 rubber dampener found in section 9D half way over the shaft. Clean the exposed shaft of grease. Slide the assembled tail rotor hub onto the rubber dampener.  
**NOTE:** To accurately balance the tail rotor, the tailrotor blades must extend straight out from the hub and parallel to each other.  
Set this entire unit in between two "glass" glasses on a flat surface. If there is an imbalance the heavy blade will hang lower. Add weight in the form of a narrow strip of colored tape or preferable use a small 3mm washer on the blade pivot bolt of the lighter blade, to balance. (If the washer is used trim the washer with a pair of cutters to achieve the proper weight needed.)  
The tail should remain in any position if balance is correct. Proper blade balance is essential. Remove the output shaft #0429 and rubber dampener #0449.

**Step 2. Assemble Pitch Slider and Bell Crank.**

Parts Required:

2	#0041	M2x8 Slotted Cheese Head Machine Screws	9B
1	#0101	M2x5 Thread Steel Ball(Short Thread)	9B
2	#0133	Long Ball Links -- Long	9B
1	#0435	Brass Tail Rotor Control Slider	9B
1	#0437	Plastic Control Slider Ring	9B
2	#0439	M6x10 Ball Bearings	9B
1	#0441	Plastic Pitch Plate - Tail Rotor	9B
1	#0443	Snap on Retainer Pitch Plate	9B

**Refer to Drawing #9.**

- A. Begin by threading the M2x5 short threaded ball #0101 into the side hole of the control ring #0437. Use cyano and thread the ball squarely in place.
- B. Place the two #0439 ball bearings (M6x10) on a clean paper with the balls visible. Lightly grease each.
- C. Slide one bearing on the #0435 brass control slider. Lightly slide the control ring over the slider, followed by the other bearing, and finally the #0441 pitch plate small end first. Press together until the bearings squarely and completely enter the recesses in the control ring. Do not force.
- D. Examine the #0443 pitch plate retainer, noting its four inside spring fingers and cupped shape. It will be pressed on the end of the brass slider to retain this subassembly, but this must be done with great care to ensure that the control ring is neither to tight nor to loose. The control ring

bearings are precise and delicate but necessary for a tight play free tail rotor control. Cut a hole just large enough to go over the end of the brass slider in a small piece of very thin plastic such as the flap from a plastic sandwich bag (Saran Wrap, etc) and place it over the slider against the pitch plate face. Rest the slider vertical against a wood or cardboard surface, pitch plate up, and press the retainer in place, cupped face **UP**. A piece of scrap wood with an appropriate drilled hole in it will be very helpful for this operation. Continue pressing the retainer in place until it seats against the thin plastic shim. Carefully tear and pull the plastic out. This should provide a subassembly in which the control ring is free to rotate smoothly but with negligible end play. Apply slow cyano to retainer clip where it touches the pitch control plate.

- E. Screw #0133 ball links to the pitch plate using M2x8 machine screws #0041. Just seat the screws, so that the links can rotate with firm pressure.

**Step 3. Assemble the Gearbox.**

**NOTE:** At the builders discretion the bearings and shaft in this section may be glued together using locktite (red, green or blue). If you choose to do this the disassemble process will become very difficult and will require application of heat to break down the glue.

**Parts Required:**

1	#0423	T/R Input Shaft	Bag 9C
4	#0025	Phillips Pan Head Self Tapping Screws M2.2x6.5	9C
4	#0051	M3x3 Socket Set Screw	9C
1	#0421-A	T/R Gear Box Housing	9C
1	#0421-B	T/R Gear Box Housing	9C
4	#0425	M5x13 Tail Gear Box Ball Bearings	9C
1	#0429	T/R Output Shaft	9C
1	#0431	E-Clip - Output Shaft	9C
1	#0433	Plastic Gear Spacer - Output Shaft	9C
2	#0427	Bevel Gears	9C
1	#0015	M2 Hex Nuts	9C
1	#0043	M2x10 Slotted Machine Screw	9C
1	#0095	Special Bolt Tail Rotor Bellcrank	9C
2	#0159	M3x7 Ball Bearings	9C
1	#0361	M2 Steel Ball	9C
1	#0001	M2 Flat Washer	9C
1	#0445	T/R Bellcrank	9C
4	#0426	.005" (.12mm) Shims	9C

**Refer to Drawing #9.**

**SPECIAL NOTE FOR INSTALLING #0427 OR #0547 TAIL ROTOR GEARS IN ALL X-CELL OR XL-PRO HELICOPTERS.**

Four #0426 - .005" (.12mm) shims are provided for adjusting the gear mesh. In most cases none will be required, however in some cases 1 or 2 per gear may be necessary to achieve optimal gear mesh.

The set-up procedure is as follows:

- 1.) Trial fit all components (without shims) and assemble gear box with a couple of the #0025 screws. To be accurate, it is necessary to insert the transmission into the tailboom each time you wish to check gear mesh. This is because the boom will slightly compress the transmission case.

Each shaft assembly should be individually test fitted with each transmission case in place to check for end-play and excessive bearing loads. The former is caused by the gear being set too far from the bearing or spacer and the later is from too much spacing causing the assembly to "snap" into place in the transmission.

2.) If it is determined that shims are required, trial fit one-at-a-time (never exceeding two in any one location) to optimize gear backlash. The above procedures must be adhered to each time a shim is tested (to avoid end play or bearing pre-load).

By examining the drawing you will see that only two positions are acceptable for shimming. Position (A) is behind the bearing nearest the gear on the input shaft and next to the stepped area of the transmission. Position (B) is outside the bearing on the output shaft but inside the flange of the transmission case.

The most desired gear mesh will be that of minimum backlash, even the point of having slight interference during rotation. This condition will "Break-in" during the first few flights. As with any similar system, we always recommend a through check over after the first 20 - 30 flights to ensure good mesh and change to new grease (to remove any break-in debris).

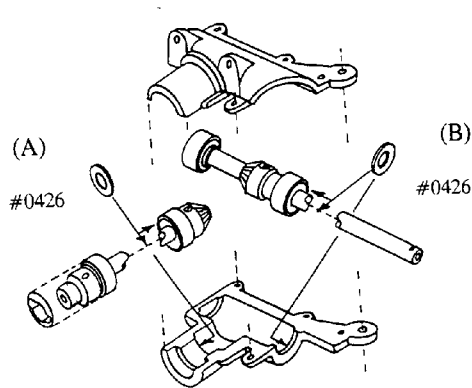

- A. At this time clean the input shaft #0423 and the output shaft #0429, the inner race on the four ball bearings #0425 and the two bevel gears.
- B. At builders discretion apply a small amount of blue Loctite to input shaft #0423 next to the delrin coupler. Slide one of the bearings #0425 all the way up against the delrin. Lay the lower half of the T/R gear box #0421-A on the table and hold the input shaft over the T/R gear box half and apply a small amount of Loctite where the second bearing goes and slide the bearing into position. Apply blue Loctite to the two M3x3 set screws #0051 and start each in to the bevel gear #0427. Place the gear on the shaft and run one of the set screws down and make sure that it is on the flat. Push this assembly down into the lower T/R gearbox half and adjust the gear so that no end play exist but without binding the two bearings. Tighten the two set screws thoroughly and set aside this assembly to cure for a few minutes.

- C. Snap the E-clip #0431 into the groove on the T/R output shaft #0429. Apply a small amount of Loctite to the small portion of the shaft beside the E-clip. Slide one of the two remaining bearings #0425 onto the shaft and up against the E-clip.
- D. Apply blue Loctite to the two remaining M3x3 set screws and start them onto the bevel gear #0427. Slide this gear onto the shaft teeth first and run one of the set screws down into the flat spot on the shaft. Slide the plastic spacer #0433 on next followed by the remaining ball bearing #0425. Apply Loctite where the bearing will sit. Lay the other T/R gear box half #0421-B on the table and place the output shaft into its perspective position. Once again adjust the gear and tighten so that there is no end play and no binding in the bearings. **Caution:** This is a small gear, do not over tighten.
- E. After curing apply a liberal amount of grease to both gears. With the two shafts in there respective positions bring the two T/R gearbox halves together and install the four M2.2x6.5 phillips screws #0025. **NOTE:** Be sure to install the screws from the correct side. Check for binding, if any - sand plastic spacer between output gear and bearing and reposition gear.
- F. Slide the T/R pitch slider onto the shaft. (Pre-Assembled in step 2)
- G. Press two #0159 ball bearings into the holes in the tail rotor bellcrank #0445, using the special bellcrank bolt #0095 to keep the bearings aligned and in place.
- H. Engage the control ring ball in the clip end of the bellcrank assembly #0445 and squarely thread the special bolt #0095 into the gear housing #0421 from the bottom. Tighten the bolt until there is no play or bearing drag.
- I. Stack onto an M2x10 machine screw #0043 one M2 steel ball #0361, followed by one M2 washer #0001. Thread this assembly into the bottom side of the tail rotor bellcrank #0445 in the center hole. Secure in place with one #0015 M2 nut. Use Loctite.

**Step 4. Install Assembled Tail Rotor Hub.**

**Parts Required:**

3	#0447-1 Locking Clips (Circlips)	Bag 9D
1	#0447-2 Groove Pivot Pin	9D
1	#0449 Rubber Dampener	9D
2	#0001 Flat Washer 2mm (small)	9D
1	#0053 M3x5 Socket Set Screw	9D

**(one #0447-1 has been supplied as a spare)**

***Refer to Drawing #9.***

- A. Press the silicone dampening #0449 sleeve onto the output shaft about 10mm. Use a 1.5 Allen wrench or a small drill to pierce through the silicone dampener and through the cross hole in the output shaft. Insert the M3x5 socket set screw into the end of the output shaft #0429 and temporarily tighten the M3x5 set screw #0053 against the Allen wrench or drill bit to ensure that no burrs exist in the shaft. Loosen the set screw and remove the allen wrench or drill bit. Check with the drawing to ensure the proper orientation of the delta tail hub before pushing it over the silicone sleeve. Hold the hub with the pin hole lined up with the hole in the output shaft then push the hub into position, a small amount of grease maybe necessary to get the hub to slide over. You may want to slide a smaller object than the pivot pin through the hub and shaft



initially to get the hub centered easily.

- B. Center the pivot pin #0447-2 in the T/R hub than apply blue Loctite to the M3x5 set screw #0053, in the end of the output shaft and tighten. **NOTE:** Do not over tighten, breakage of the pin could result.
- C. Place a M2 washer #0001 on the pivot pin then snap the clip #0447-1 into the groove. Repeat this process for the other end of the pin.
- D. Snap the two ball links #0133 onto the balls #0103 on each tail rotor blade mount.

X. **BUILDING THE TAILBOOM**

Step 1. **Installing Wire Drive.**

Parts Required:

1	#0471	Aluminum Tailboom	Bag# 10A
1	#0474	T/R Brass Drive Shaft Tube	10A
4	#0475	Drive Shaft Tube Guides	10B

*Refer to Drawing #10.*

- A. Sand the brass tube #0474 with 80 grit sand paper before assembly. Assemble as follows: Slide the four drive shaft tube guides #0475 on the brass tube #0474, all oriented alike; equal distance between each and placing the outer two approximately 6mm (1/4") from each end. Anchor in place with epoxy glue only. Slide the resulting assembly in position in the tail boom #0471, approximately centering it and drip some cyano glue down the inner wall of the tube from each end in turn, holding the tube at the proper angle, and rotating it to allow the glue to flow down to bond the end guides #0475 in place.

Step 2. **Installing Tail Rotor Push Rod Guides and Fin Mounts.**

Parts Required:

1	#0495	Aluminum Tailboom Support Strut	Bag# 10A
1	#0483	Rear Tail Boom Support Fitting	10C
1	#0375	T/R Push Rod (700mm)	10A
1	#0377	T/R Push Rod Extension	10A
1	#0481	Horizontal Fin	10A
1	#0486	Vertical Fin	10A
4	#0477	T/R Control Rod Guides	10C
1	#0385	T/R Control Rod Coupler	10C
1	#0479	Horizontal Fin Mount	10C
1	#0683	Tailbox Clamp(with pre-drilled hole)	10C
		Assembled Tail Rotor Gear Box (From Section X)	
4	#0015	M2 Hex Nuts	10C
4	#0043	M2x10 Slotted Machine Screws	10C
2	#0019	M3 Locknuts	10C
5	#0025	M2.2x6.5 Phillips Screws	10C
5	#0032	M2.9x9.5 Phillips Screws	10C
3	#0063	M3x10 Socket Head Bolt	10C
1	#0071	M3x18 Socket Head Bolt	10C

2	#0133	Plastic Ball Links(Long)	10C
1	#0187	Front Tail Boom Strut Support	10C
1	#0491	T/R Drive Shaft	10A
4	#0057	M4x4 Socket Set Screws	10C

**Refer to Drawing #9 and #10.**

**NOTE:** The notched end of the tail boom is the rear (Tail Transmission) side.

- A. Slide the #0479 horizontal fin clamp onto the tailboom 8" from the rear. Loosely mount the four tailrotor control rod guides #0477 by wrapping them around the boom and securing each with an M2x10 machine screw #0043 and a M2 hex nut #0015. Mount one between the horizontal fin clamp #0479 and the "rear" end of the tailboom and mount the other three in front of the horizontal fin clamp.(The screws are long enough to allow the control rod to be snapped in from the sides when needed). Measuring from the notched end of the tailboom, the first control rod guide should be 125mm from the end. The next guide should be 190 millimeters from the first one. The next 2 guides should be 190 millimeters apart.
- B. Slide the Tailbox clamp #0683 onto the boom and install the M3x10 bolt #0063 and M3 locknut #0019 which squeezes the clamp together. Do not fully tighten. **NOTE:** Notice that the boom is notched and that the tail box has a key on one side which when inserted into the boom notch will prevent any rotation of the tailbox.
- C. On the input shaft of the tail rotor assembly, note the two threaded cross holes in the large diameter. Select two M4x4 socket set screws #0057, apply Loctite, and thread them partially in place.
- D. Identify the flat on one of the drive shaft #0491 and, orienting it so that it faces one of the set screws, insert the drive shaft in the end hole of the input shaft as far as it will go. Tighten the set screw lightly against the flat (make certain of this orientation) and then tighten the opposite set screw. Then tighten the first set screw. Re-check the tightness of both set screws.
- E. Lightly grease the drive shaft and slide it into the tailboom from the fin end until the tail rotor drive housing enters the boom. Press the housing halves together and orient so that the ridge of the housing enters the notch. Push it on until transmission butts up against the tail boom. Slide the clamp #0683 up against the tailbox and align the three holes. Screw the tailbox to the clamp using the three M2.9x9.5 Phillips screws #0032 and slow cyano. Ensure that the tailbox is fully seated then tighten the M3x10 bolt in the clamp.
- F. There is a small hole pre-drilled in the top of the clamp #0683. Using a #55 or a (.052) drill bit, drill through the boom and the top half of the tailbox. The bit will stop when it hits the input shaft. Install one M2.2x6.5 Phillips screws #0025 into this hole. This screw will act as a safety to ensure that the tailbox cannot be ejected.
- G. Using slow epoxy glue or J.B. Weld epoxy, glue one #0187 front tail boom strut support and one #0483 rear tail boom support fitting into each end of the aluminum tail boom support strut #0495. Lay the assembled support strut on a flat surface and drill a hole, one on each end midway through the aluminum tube into the plastic fittings, using a #49 or 1.8mm drill bit. Install one #0025 screw in each hole. View the drawing to verify correct orientation of the boom support #0395. Bolt this support to the horizontal fin clamp using a M3x18 socket head bolt #0071 and a M3 locknut #0019. Do not tighten.
- H. If you are electing not to paint the fins you may install the horizontal fin #0481 and the vertical

fin #0486 at this time. Install the two remaining M2.2x6.5 Phillips screws #0025 in the two holes in the top of the horizontal fin #0481 and into the fin mount #0479. A small amount of Goop or silicone glue under the horizontal fin #0481 will help extend the life of the fin. Use two M2.9x9.5 Phillips screws #0032 to mount the vertical fin into the tail rotor transmission mount #0683.

- I. Examine the central rod coupler #0385, noting that it will accept the control rods beyond their threaded portion. The intent is to better support the rods against bending. Use the coupler to join the tail rotor control rod #0375, and the tail rotor control rod extension #0377. (Protect the rods with tape or cloth when clamping them to allow the coupler to be screwed on.) Be sure both rods enter the coupler approximately 6mm in depth. Start a long plastic ball link #0133 on each end of the push rod. Exact adjustment will be made later.
- J. Take the tail assembly and slide it partly into position between the halves of the front tail boom support. Holding the helicopter so that the end of the front tail drive shaft is visible ahead of the support, slide the boom further while engaging the drive shaft in the hole in the tail drive #0239. Slide the boom further until its front edge is flush with the front of the support. The drive shaft should project well into the tail drive but should not bottom. Sighting from the rear of the helicopter, rotate the boom until the vertical fin is parallel to the main shaft, and tighten the four support screws snugly. **Option:** Due to the size of some workshops and the aggravation of spinning a model around on the table wondering what you are going to knock over next with the tailboom, you may want to wait until you've finished setting up the main mechanics before installing the tailboom.
- K. Identify the two frame holes through which the front tail drive can be seen and visibly locate the drive shaft flat. Select an M4x4 set screw #0057, apply Loctite and by holding it on a Allen wrench, screw it into one of the threaded cross holes in the shaft. Be positive that the flat on the drive shaft is felt under the set screw. Tighten only until contact is made, then add the second M4x4 screw in the opposite hole and tighten. Then tighten the first screw. **(This sequence is important.)**
- L. Slide the fin clamp #0479 forward while guiding the lower boom support mount at the other end of the boom support assembly #0495 between the lower mainframes. Align the support with the two holes in the mainframe then thread two M3x10 socket head bolts #0063 into the mount and tighten. Rotate the horizontal fin mount back and forth slightly to ensure that it is not pushing or pulling the boom into a bind. Align the horizontal fin perpendicular to the mainshaft and then tighten the M3x18 bolt in the horizontal fin mount #0479.
- M. Temporarily install the tail rotor push rod into the four pushrod guides #0477 and the front rod guide #0387. Align all the pushrod guides so that there is no binding throughout the travel of the pushrod. Snugly tighten the rod guides. Do not over tighten and cause binding.

## XI. INSTALLATION OF REMAINING RADIO EQUIPMENT, ASSEMBLING AND INSTALLING PUSHRODS.

### Step 1. **Install the Switch for the Receiver, Gyro , Radio Receiver, Battery and the Antenna**

#### Parts Required:

- 1 Gyro Unit

***Refer to Drawing #11 and #7.***

- A. Provisions have been made in plastic tray switch plate #0575-8 for the receiver switch and the gain box for the gyro. If you elect to use these positions. Mount the two devices at this time.
- B. Mount the gyro motor assembly onto the servo tray or the tank support tray #0189 using two layers of double-side servo tape to help isolate it from vibration. (Order #3869)
- C. Plug all your servo leads into the receiver. Do not allow any wires to rub any moving part.
- D. Mount the gyro amplifier on the bottom side of the plastic servo tray just ahead of the servo tray stiffeners #0578-1. Use double sided servo tape to secure in place.
- E. Wrap the receiver and battery in foam and mount on the front of the plastic servo tray. the battery mounts best on the underside. Secure with either velcro or tie wraps loosely pulled.
- F. If a whip antenna will be used, tests have proven that the best place to mount the antenna base is on the radio plastic tray #0575 sticking straight forward.
- G. If you are electing to use a full length antenna, route it out of the canopy then down to the landing gear strut next to the skid and then back up to the tailboom. Again ensure that the wire doesn't rub any corners and is free from moving parts.

**SPECIAL NOTE:** If using a computer radio, clear all ATV's to 100%. Clear normal throttle and normal pitch curves so that they are symmetrical and throwing to their limits. Clear sub trims, trim memory, stunt trims, or anything that would change servo centering. Check direction of the servos.

In the following steps, be sure to use Loctite on all steel threaded balls nuts and screws. All measurements given for pushrods are from the inside of the ball links at the connection point with the push-rods. Unless otherwise specified.

**Step 2. Install Rudder Pushrod.**

**Parts Required:**

1	#0043	M2x10 Slotted Machine Screw	Bag 11A
1	#0361	M2 Steel Ball	11A
2	#0015	M2 Hex Nut	11A

**Refer to Drawing #11.**

- A. Activate electronic tail rotor compensation (ATV) for "RIGHT" (Clockwise) rotor rotation. Check direction of tail rotor compensation and gyro. Put collective stick at the mid-position. Position a servo wheel on the tail rotor servo wheel on the tail rotor servo that it is square to the servo. As per the drawing, install one M2x10 slotted machine screw #0043, one M2 steel ball #0361 and one M2 Hex Nut #0015 into a hole at least 11mm out on the servo wheel and mount it at 90 degrees facing inward, Secure with Loctite using one M2 hex nut #0015.

**NOTE:** The Rudder ball on the servo wheel will be in a neutral position at 1/2 collective stick.

- B. Bend the tail end of the tail rotor control rod approximately 168 degrees in order to align with the tail rotor bellcrank #0445. Snap the rear ball link #0133 onto the steel ball in the tail rotor bellcrank #0445. Adjust the position of the four rod guides along the boom to allow a free-sliding control rod and tighten their screws as well as the one in the front rod support. (Use Loctite.)

Attach the front ball link to the rudder servo. Adjustment of the control rod will come later.

### Step 3. Install Elevator Pushrods.

#### Parts Required:

2	#0133	Ball links (long)	11B
1	#0043	M2x10 Slotted Machine Screws	11B
2	#0015	Hex Nuts 2mm	11B
1	#0367	Control Rod M2x60	11B

#### Refer to Drawing #11.

- A. Select the #0367 elevator control rod and two #0133 long ball links. Thread the links on the rod until the gap between ball link base to ball link base (Exposed 2.0mm wire) is 47mm.
- B. Select a servo wheel with a minimum O.D. 24.5mm and mount it on the elevator servo with a selected hole 10.0 to 12.0mm from center. The selected hole should be mounted vertically upwards and parallel to the main shaft. Into the selected hole install one #0361 steel ball using one M2x10 #0043 screw with M2 nuts #0015 as spacers and retainers. This is to say that the screws are installed from the outside with a nut next to each surface of the plastic wheel. If there is not adhered to, it is possible interference could result during operation.
- C. Snap the previously assembled push-rod onto the #0105 ball of the elevator bellcrank #0157 and the elevator servo.

### Step 4. Install Aileron and Collective Pushrods.

#### Parts Required:

1	#0043	M2x10 Slotted Machine Screw	Bag 11C
2	#0371	Threaded Pushrods M2x90	11C
6	#0133	Ball Links (long)	11C
1	#0359	Roll Servo Link Retainer Bar	11C
3	#0361	M2 Steel Balls	11C
7	#0015	Hex Nuts 2mm	11C
1	#0101	Threaded Steel Ball M2x5	11C
2	#0045	M2x14 Threaded Machine Screws	11C
1	#0369	Collective Control Rod M2x35	11C

#### Refer to Drawing #11 and #7.

- A. Study the drawing showing the special control arm assembly on the aileron pivoting servo. **NOTE:** that the three control rods running to it have their ball links trapped by the arm assembly and therefore, must be fabricated first.
- B. Thread one #0133 ball link onto each end of the collective push rod #0369 until a distance of 21mm is achieved between the ball links.
- C. Select the two thread pushrods M2x90 (curved) #0371 and thread one #0133 ball link(long) onto each end of both control rods. Thread the links on the curved ends of the rods until the base of the ball link #0133 is 11mm from the center of the bend in the rod #0371. Thread the remaining ball link on until a distance of 72mm is achieved between the base of the links.

- D. Snap one M2 steel ball #0361 (drilled version) in the ball links on the bent ends of the two aileron rods #0371.
- E. Insert one M2x5 threaded ball #0101 in the center hole of the roll servo link retainer bar #0359 from the bottom and secure it with one hex nut M2 #0015. Use Loctite.
- F. Select a double ended servo arm from the radio system hardware, long enough to match the 24mm hole separation on the retainer bar. If necessary, obtain an un-drilled arm or wheel and drill and shape it to suit. Center the servo electronically and mount it exactly parallel with the servo lengthwise.
- G. Insert an M2x14 screw #0045 in each end hole of the retainer bar, slide an aileron roll bar on each and secure with an M2 hex nut. Snap the collective rod ball link on the center ball and mount the assembly of the three rod to the servo arm. Secure with two M2 hex nuts from underneath the arm. Tighten securely using a small wrench or long-nosed pliers. Use Loctite. Check the configuration against the drawing. (collective rod forward).
- H. Select a servo wheel with a minimum O.D. 24.5mm and mount it on the collective servo with a selected hole 12.0 to 14.0mm from center. The selected hole should be mounted horizontally inwards and parallel to the aileron servo opening. Into the selected hole install one #0361 steel ball using one M2x10 #0043 screw with M2 nuts #0015 as spacers and retainers. This is to say that the screws are installed from the outside with a nut next to each surface of the plastic wheel, if this is not adhered to, it's possible interference could result during operation. Snap the previously assembled collective pushrod onto the #0361 ball on the collective servo.
- I. With the collective stick at open one-half position, the aileron servo should be exactly vertical and both aileron bellcranks are vertical (or level). Adjust the aileron rods #0371 until the bellcranks #0167 are positioned correctly. Keep both aileron rods the same length.

**Step 5. Install Throttle Pushrod.**

**Parts Required:**

1	#0373	Threaded Rods M2x130	Bag 11D
2	#0133	Ball Links (long)	11D
2	#0361	M2 Steel Balls	11D
4	#0015	Hex Nuts 2mm	11D
2	#0043	M2x10 Slotted Machine Screws	11D

**Refer to Drawing #11.**

- A. Install one M2x10 slotted machine screw #0043, one M2 steel ball #0361, and one hex nut 2mm #0015, into the carburetor arm (outer hole). Secure on the back side with a hex nut 2mm #0015. Use Loctite. Adjust the carburetor arm so that it throws in a symmetrical arc on the upper side of the carburetor.
- B. Start a long ball link #0133 on each end of the throttle pushrod #0373.
- C. With the collective stick in the middle position, mount a servo wheel on the throttle servo pointing straight down. Position the carburetor at 50 percent or half-throttle. Adjust the throttle pushrod so that it is the same length as the distance between the carburetor arm and the center of the servo arm. Snap the pushrod on the carburetor. Move the collective throttle stick from high to low with the throttle trim full down moving the throttle rod with it to determine where

the control ball should be positioned on the servo wheel.

- D. As described in step "A" install another steel ball assembly into the throttle servo wheel. Snap on the pushrod then adjust the A.T.V.'s at full and low stick to fine tune the throw.

**Step 6. Install Rotor Head, Flybar and Hiller Control Rods.**

Parts Required:

8	#0133	Ball Links (long)	11E
4	#0135	Ball Links (short)	11E
2	#0313	Threaded Rods M2x10	11E
2	#0335	Threaded Rods M2x75	11E
2	#0337	Threaded Rods M2x27	11E

***Refer to Drawing #11.***

- A. Remove the special head bolt #0091 from the head, slide the head down onto the mainshaft and align the hole on the top side of the main shaft with the hole in the head block. This can be accomplished by holding the rotor head in one hand and spinning the maingear clockwise with the other. Re-install the special bolt and tighten.
- B. At this point check to see how free the washout block slides up and down the guide pins #0297 in the bottom of the head block. If it is stiff, disengage the wash out block and rotate it 180 degrees and try again. Determine which way is best and use pliers to tweak the pins a small amount as needed to one side or the other until the washout block slides up and down the pins with a minimum of drag.
- C. Start a long ball link #0133 on each of the two flybar control rods #0337 and adjust to 9mm. Snap both control rods to the flybar control arms and washout arms.
- D. Start a long ball link on each end of the Hiller control rods #0335 and adjust to a length of 58mm. These rods go from the bell mixers on the blade holders to the swashplate. Snap both into position.
- E. Start a short ball link #0135 on each end of rod #0313 and adjust to a length of 1mm between the ball links. These rods go from the bell mixer to the delta plate on the rotor head.

**Step 7. Collective Decal.**

Parts Required:

1	Degree Decal from Decal Sheet #0500
---	-------------------------------------

***Refer to Drawing #11.***

- A. If you desire. The degree decal may be applied to the left main frame as per the drawing. Clean surface well before applying.

## **XII. CANOPY PREPARATION**

### **Step 1. Assemble Canopy and Paint**

#### **Parts Required:**

1 #0497 Canopy (2 pcs)	Box
1 #0499 Canopy Latch	Bag #11F
1 #0500 Trim Decal Sheet	Box
1 #0498 Rubber Band	Bag #11F
1 #0502 Special Canopy Bonding Adhesive (optional)	

#### ***Refer to Drawing #12.***

- A. Examine the two Canopy halves. Note that they have been die cut to minimize cutting and trimming operations before bonding together. It is still necessary to cut out the back, top and bottom portions along the molded-in guide lines. Use scissors and/or a Dremel tool or a hot knife (a small soldering iron fitted with a collet to hold an "x-acto" blade).
- B. Clean the bonding surfaces of the Canopy parts carefully and moderately sand using 80-100 grit sandpaper. Apply glue (#0502) to one side only. Align the surfaces to be bonded and secure in place using masking tape or paper clamps. Re-check parts alignment.
- C. Cut small reinforcement strips and bond one at the end of the glue bead on the bottom of the canopy and the other just inside the upper end of the seam leaving room for the canopy latch. Refer to the drawing for placement. Allow 3-4 hours partial cure time, 24 hours full cure time.
- D. Trim the canopy edge to 3mm (1/8") all around and sand all plastic edges smooth. (Protect the canopy surfaces with masking tape.)
- E. Using glue #0502, mount the #0499 Canopy Latch in place.
- F. Carefully wash the canopy with detergent. Mask the window area, sand the area to be painted with a scotch brite pad or 320 grit sand paper. Paint as desired.
- G. The decorative Trim Decal Sheet can be used to finish the Canopy as desired.

## **XIII. BUILDING THE ROTOR BLADES.**

### **Step 1. Assembling Blade Mounts**

#### **Parts Required:**

2 #3651	Main Rotor Blades	Wrapped in Box
4 #0034	M2.9x13 Phillips Screws	Bag #12A
2 #3721	Blade Mount Reinforcements (2 pr) (Upper & Lower)	Bag #12A
2 #3723	Brass Blade Bushings	Bag #12A

#### ***Refer to Drawing #13.***

- A. Sand each rotor blade with 220 or 320 grit sandpaper until very smooth. (Use of a sanding block and proper attention to thin trailing edges will ensure retention of the correct airfoil. Be certain the trailing edge remains straight during this operation.)



- B. Lay all four blade reinforcement halves on a table with insides facing up. Match male and female reinforcement halves together. Using slow cyano only, choose the male reinforcement half and apply even amounts of slow cyano to inner surface of reinforcement and line up with rotor blade root. Push reinforcement onto blade root until it is completely snapped down. It may be necessary to use a rubber hammer for this step. Take care not to damage rotor blade. Immediately apply cyano to matching female reinforcement half and assemble on blade in the same manner as the first half. Press the brass bushing #3723 completely into blade mount pivot hole. Insert two #0034 M2.9x13 Phillips screws into remaining two holes in blade mount reinforcements. Next, apply pressure to the reinforcement halves by either clamping together or using a heavy object as weight on top of the blade reinforcement. Tighten securely. Set aside and allow to dry and repeat process on second blade.

## Step 2. Adding Lead Strips

### Parts Required:

2 #3710	Lead Strips	Bag	#12B
2 #3712	Balsa Strips		#12B

### Refer to Drawing #13.

- A. Cut the lead strips #3710 equal in length to the slots provided in the main rotor blades and equal length to each other.
- NOTE:** Using a sanding block, sand each lead strip on a flat surface by rolling under sanding block.
- B. Place all the lead strips in their respective slots and weigh the blades on a gram scale or our new blade balancing system #0514. The total weight should be the same. If not, trim the lead in one of the slots until equal weight is achieved.

**NOTE:** If a gram scale is not available the following guide may be used:

Net blade weight (weight is written or root of blade)	+ _____ grams
Full length of lead strip w/balsa caps	+ <u>  21  </u> grams
Blade covering installed	+ <u>  14  </u> grams
Approximate weight of blade mounts installed	+ _____ grams

- C. If less weight is desired, trim one of the lead pieces in each blade until desired weight is achieved.
- D. If more weight is desired, you may also add bronze powder #3709 to the blades.
- E. Starting at the outer end of the slot, apply a coat of thin cyano around the lead in the slots. Allow to sit for about 30 seconds, then apply cyano accelerator. Repeat this process until near the top. A small gap must be left as to allow room for the balsa strip #3712.

## Step 3. Initial Balance.

### Refer to Drawing #13.

- A. As an initial step in balancing, we will now establish the center of balance point. Using a BIC type pen, dowel, or tube of any type, position the blade lengthwise in front of you on a level

surface. Using the pen as a fulcrum at 45 degrees to the leading edge, determine the balancing point, mark the blade accordingly, and repeat at 90 degrees to the previous line. (Hint: Gently rotate the pen right or left until the balance is established, and mark well for future reference, even after sanding). Both blades should balance within 1-2 millimeters of each other. Since they were factory matched and all material added accurately measured, you should have no difficulty. However, if there is an imbalance, the blades may be matched by two possible methods. First, determine which blade you wish to shift and in which direction. For example, if tip weight is to be added, simply rout out a small area at the tip of the blade slot and glue in a small amount of the excess lead strip as needed. Keep in mind that any weight added to the blade being corrected, must also be added to the other blade at the **center of balance point**, thus retaining the original balance of the two blades. The optional bronze #3709 powder may also be used as a balancing aide.

- B. Cut balsa strips #3712 for each slot and trim to fit (i.e. round corners). Press balsa firmly into slots and secure with cyano on all sides. Block sand the raised portion until flush with the blade surface. Coat with a film of cyano and wipe away excess.
- C. At your option, seal the wood at the hub and tip areas with either instant cyano or fuel-proof paint. Lightly re-sand blades with 220 or 320 grit sandpaper once again. Carefully remove all dust using a clean towel or a tack rag, wiping several times. A clean blade is a must for proper adhesion of the blade covering material.

#### Step 4. Cover Blades.

Parts Required:

2 #3701	Blade Covering	Box
1 #0500	Blade Balance Decal Sheet	Box

*Refer to Drawing #13.*

- A. With the blades now ready for cover, select a clean flat surface and after removing the backing material from a piece of blade covering #3701, lay it adhesive side up. Now carefully measure 10mm in from the near edge and mark each end with a ballpoint pen. Holding the blade with the hub in your left hand and the blade tip in your right hand, set the trailing edge down on the mark from the left end of the covering in a position to just clear the base of the hub when it is wrapped into position. Rock gently to adhere the covering to the trailing edge.

At this point, the 10mm section of blade covering will be visible between yourself and the blade trailing edge. Fold the blade toward yourself and apply pressure on the 10mm section of the marked covering. This will establish the bottom of the blades. Lift the blade up with covering clinging to the trailing edge and firmly smooth the short 10mm side onto the underside of the blade with a continuous slide of the finger. Continue rubbing the entire trailing edge as you rotate the blade upright. Do not allow the covering to touch the top blade surface until the trailing edge is firmly bonded with a clean, sharp fold.

Now rotate the blade further and progressively smooth the covering end to end as you go. Continue around the leading edge and back to overlap the starting edge of the covering on the bottom of the blade. Trim excess covering neatly from the blade and smooth the entire surface again. Repeat this process with the other blade. Note: A useful technique to allow good control of this sticky material and to prevent it from prematurely adhering to the blades in any area, weight the covering by sticking a piece of wire on what will be the final edge of the covering to be adhered, before starting. This will cause the covering to maintain a

continuous roll-away from the blade surface until deliberately pressed down. Repeat entire process with the remaining blade.

Step 5. **Final Balance of Blades and Rotor Head.**

*Refer to Drawing #13.*

Equipment Required: **NOTE:** The performance potential of modern R/C helicopters is so great that the use of specialized equipment for proper assembly and set-up is fully justified by the results achieved. This is particularly true of balancing procedures for all rotating parts. Nothing so clearly distinguishes one helicopter from the rest as perfect blade tracking and freedom from vibration. This manual describes only the procedure usable without special equipment which includes balancing the fly bar on its own bearing in the pivot block, and then suspending the head with main blades from the flybar across two straight edges, such as two rectangular blocks of wood. This procedure has been proven very effective and produces a vibration free head. The ultimate in head balance can be achieved by using a good static balancer such as the balancer #0514 sold by Miniature Aircraft USA or its equivalent. Its value lies in its ability to include main blade balance. If you have such a unit, use it following the instructions with it.

- A. First determine the type of flight characteristics you would like to see your model respond to. This step would have been completed in Section 1, Step 6, Paragraph A. Center flybar #0303 on main rotor head #0289. Flybar measurements should be equal distance from tip of flybar paddle to delta offset plate #0339. Make sure main rotor blades are snug in blade holders #0317 and blades are extended out in a straight line to each other for normal flight condition. With main rotor blades perpendicular to tailboom, view flybar from the front of the helicopter. Manually place flybar in a horizontal position and note paddle reaction. If paddles remain horizontal paddles are balanced. If flybar falls to one side, try adjusting the last screw placed in the flybar paddle; in or out to see if balance improves. If condition remains the same remove the last brass insert #0561-1 from the heavy paddle and grind small quantities of brass material from brass insert until paddle balance is achieved. This concludes flybar balancing.
- B. Remove the rotor head from the main shaft. Mount the main rotor blades to the head using M4X35 socket head bolt #0082 and M4 lock nuts #0021, temporarily installed in section I. Position the blades straight out from the head and tighten the screws just enough to hold the blades in position.
- C. Obtain two wood blocks at least 75mm (3 inches) high with parallel surfaces (2 short sections of good quality 2x4 serve very well) and two single side razor blades. Then, suspend the head and blade assembly between them supported on the fly bar. One main blade will invariably tilt downward.

**Note:** As described, before rotation of main blade on rotor head may result in a better balance. Cut a partial strip of the red tape provided (the degree of unbalance will give an indication of the width necessary) and apply near the end of the light opposite blade. Just stick a corner of the tape to the blade until the exact amount is determined. When exact balance is achieved (when the blade tips are equal distance from the bench top) apply the tape to the blade starting underneath, as with the regular covering.

- D. Re-install the entire balanced rotor head assembly onto the main rotor shaft.

#### Step 6. **Adjustment of Static Tracking.**

- A. Screw in (2) M3x8 socket set screws #0563-2 at the base of the main rotor head block until they just contact the mainshaft. Stand your transmitter antenna (or something else to use as a measure) under the tip of the one blade and rotate the head carefully to make a comparison of the tip height of each blade. Adjust each set screw until moderate pressure exists on the main shaft and each blade tip is at the same height.

#### **First Flight Tip**

After hovering the model, land and let blades stop by themselves. Recheck tip height and readjust, if necessary. **IMPORTANT:** Always be sure that the blade pivot bolts are quite snug--offering significant resistance to the lead/lag of the blades. Also, after this procedure, it may be necessary to readjust the tracking slightly.

### XIV. **FINAL MECHANICAL AND ELECTRONIC SET-UP**

#### Step 1. **Setting up the Collective Servo and Collective Arm.**

*Refer to Drawings #11 & #14.*

- A. Move the collective stick slowly all the way to the top and check that the collective arm is going as far as possible without putting the elevator bellcrank #0157 in a bind where it sticks through the mainframe and adjust ATV as necessary.
- B. Move the collective stick slowly all the way to the bottom and adjust the ATV so that the collective arm goes all the way to the bottom without binding.
- C. With the pushrod lengths given you should be able to use 100 to 110% ATV travel on the pitch servo.
- D. With the collective stick at the top check that the swashplate is moving all the way to the top without binding. Adjust the four lower swashplate rods #0227 if necessary.
- E. Once again check all collective and aileron, servo's, bellcranks, and pushrods at one half throttle stick for vertical and horizontal positioning.

#### Step 2. **Final Swashplate and Fly-Bar Alignment.**

*Refer to Drawing #11 & #14.*

**NOTE:** Miniature Aircraft offers both swashplate and fly-bar alignment tool kits. Order #0510 and #0512.

- A. **Swashplate:** A final check for a level swashplate may be achieved with the use of a main rotor pitch gauge (#0526) and a fly-bar lock (#0505). All transmitter stick and servo arms should be in a neutral position. Snap the fly-bar lock into the rotor head. Position the pitch gauge on one main rotor blade and set the pitch reading in the blade. Rotate the main rotor head in all four 90 degree positions. If the swashplate is truly level, the pitch reading will remain the same in all four positions. If incorrect, adjust the rods just below the swashplate until a level swashplate is achieved.
- B. **Fly-Bar Paddles:** Now that the swashplate has been leveled, the fly-bar paddles may also be leveled, set your pitch gauge on 0 degrees. position on the paddle and adjust the paddles until they are level(Parallel) with the main rotor head. A straight rod such as a fly-bar may be used on the rotor head top as an aid in aligning the paddles. It is very important that the fly-bar control #0307 and the fly-bar paddles are all parallel to each other. For an excellent aid order #0510. (Fly-Bar alignment tool kit).

### Step 3. **Adjusting Pitch Curves.**

*Refer to Drawing #14.*

- A. If you have selected an FAI type set up, you will probably want to run, depending on blade selection, 5 to 6 degrees of pitch in a hover (one half collective stick position) with about 10 degrees of pitch at full stick position and about 3 degrees of negative at low stick position. For the idle-up(s) you will want around 4.5 to 5 degrees of pitch at hover, 8.5 to 9.5 degrees at full top and 2.5 to 4 degrees of negative at low. For throttle hold, you will need about 5 degrees at hover, 11 or 12 degrees of positive at full and 4 to 5 degrees of negative at the low.

If you are setting up for hot-dogging, normal stick for hovering should be roughly the same as an FAI set-up. The same is true for the first idle up if your radio is equipped with two idle ups. You would use the first idle up for doing normal aerobatics, then the second idle up would be set up with 0 degrees of pitch at half stick, 4 degrees of negative at quarter stick, 4 degrees of positive pitch at three quarter stick and between 8.5 to 9.5 degrees of positive pitch at full and between 8.5 to 9.5 degrees of negative pitch at low. Throttle hold should be similar to the FAI set up, with the exception of maybe having a little more negative pitch at low for quick descents.

### Step 4. **Adjusting Swashplate Throw.**

*Refer to Drawing #14.*

- A. Set the pitch gauge for 0 degrees of pitch. Move the collective stick until pitch gauge lines up with flybar. Set the pitch gauge for -6 degrees and with the main blades running parallel to the tail boom, give full right cyclic and adjust ATV so that the rotor blade has -6 degrees of cyclic pitch change. Repeat this process for the other side using +6 degrees on the pitch gauge. Repeat process for the elevator set up. This is the recommended maximum amount of swashplate travel that should be used.

### Step 5. **Adjusting Rudder.**

*Refer to Drawing #14.*

First check servo for proper directional travel. Right tail stick command pulls the pushrod forward. Reverse if necessary. Turn on the ATS mixing function (for right hand rotation) on your transmitter. The 0 point should be at 1/2 throttle stick position. Adjust the low and high point to approximately 25% each. This will provide a good starting point for your first flight. Check for proper compensation direction by increasing the throttle stick. This should result in pulling forward like a right hand command. Re-Check that at 1/2 throttle stick the rudder servo arm has remained in neutral. With the throttle and rudder stick in their center position adjust the tail rotor control rod until the outer hole in the tail rotor bellcrank #0445 is approximately 1-2mm rearward from the back edge of the tail rotor transmission housing #0421. This should result in approximately 20mm distance between the tail rotor blades when folded together. Check both left and right tail rotor commands at low and high throttle positions for no binds. Adjust transmitter ATV's if necessary.

### Step 6. **Gyro.**

- A. Carefully read the gyro instructions provided. Set gyro sensitivity to approximately 40-50%. Turn gyro and radio switches on and check for proper gyro/rudder direction operation. Helicopter nose pulled to the left should result in a right tail rotor command. Reverse gyro if incorrect. When using a gyro, a battery pack with 1000mah minimum is recommended. When switching gyro on and off, observe that rudder servo retains its same centering position. If needed, adjust gyro centering per gyro instructions.

## Step 7. Elevator and Aileron Dual Rates and ATV's.

Depending on the characteristics of which you desire dual rates should be set for your flying style. A starting point of about 70% on aileron and elevator work well. ATV's should be set for no binding.

### XV. FINAL ASSEMBLY AND BALANCE

Parts and Equipment Required:

1 Helicopter Muffler or Tuned Pipe with Mounting Hardware

- A. Install the Muffler or Tuned Pipe per its instructions. Connect a section of fuel line from the Tank clunk fitting to the carburetor, incorporating a fuel filter (not supplied) is recommended. Add a (muffler to tank line), with filter, if tank pressurization is desired.
- B. Balance: Check the completed helicopter by suspending it from the flybar (with the flybar crosswise) just above a level surface. With an empty fuel tank, it should remain level or tilt forward no more than 6 or 7mm (1/4") as measured over the length of a skid. Adjust battery pack position (or similar system element) to achieve this.

### XVI. FINAL ASSEMBLY INSPECTION

- A. Recheck entire machine for any loose nuts, bolts, or screws.
- B. Re-check plans for proper installation.
- C. Inspect radio installation. Check to see that there is no mistake in the operational direction of each servo with no binds.
- D. Check all rod connections for proper installation.
- E. Check all moving components on helicopter for bind free operation.
- F. After completion of the final inspection, we recommend that you familiarize yourself with all stick movements, switches and functions of the radio system as it relates to your helicopter. Practice until you feel comfortably ready for your first flight. Be careful to always ensure that the batteries in your radio system are fully charged before each flying session. We recommend the use of a good battery voltage meter to monitor the voltage level during use.

### XVII. NECESSARY FLIGHT ITEMS

- A. Obtain items necessary for flight use
  - 1) Glow fuel(Nitro; about 10 - 30%)
  - 2) Fuel pump (electric or manual)
  - 3) Electric starter (12v)
  - 4) Special starter extension (Part #4681 from Miniature Aircraft, USA)
  - 5) 12v battery (preferably a gel-cell; 5.5 amp minimum)
  - 6) 12 volt charger
  - 7) 1.5v glow plug battery with charger
  - 8) Extra glow plugs
  - 9) Ample tools for field use
  - 10) Frequency flag displaying your transmitters' frequency colors or numbers  
(Supplied with your radio system)
  - 11) Power Panel (optional)

B. At the Flying Field:

- 1) Obey any flying field rules
- 2) Check the frequency board or any fliers for frequencies in use before turning on your transmitter
- 3) Perform a pre-first flight radio range check as per radio specifications
- 4) Pre-check all radio functions
- 5) Check for possible help from other helicopter pilots
- 6) Be sure not to leave radio unit on between usage

**XVIII. STARTING AND STOPPING OF THE ENGINE**

**TO START:** Always start the engine by using the transmitter trigger only (high throttle trim, low throttle stick). Check idle-ups and throttle hold for proper position of switches (off). Connect the glow plug battery connection selected to the engine glow plug. Connect the starter to the 12v battery and check that it operates in a counter-clockwise rotation. Hold the rotor head firmly with one hand. Engage the starter extension on the starter with the starter cone on top of the engine start shaft and rotate. When the engine starts remove the starter and glow plug battery.

**TO STOP:** Set the transmitter throttle stick and trimmer to its lowest setting. If it does not stop, but is running slow enough to halt the rotor blades, then do so and remove the fuel line to stall the engine. In this case, re-adjust throttle ATV until engine may be stopped by use of a transmitter trimmer. (After daily use of your model, we recommend the use of an after run oil for engine protection.)

**XIX. FIRST FLIGHT ADJUSTMENTS**

**NOTE:** After the first flight remember to check the static tracking.

A. Before flying double check direction of each control; tailrotor compensation direction and gyro direction. The first few flights should be limited to hovering only.

B. **Engine Carburetor Settings:** With the engine running, set the idle adjustments to enable the engine to maintain a rich reliable idle (trying to four cycle) at low throttle, mid to high trim. Set the high speed needle to accelerate, but slightly rich. The motor should transition smoothly from high rpm's to low rpm's during the flight of the helicopter. Short duration vertical climbs to test the top end are the safest method to get the high speed needle valve setting close.

**Throttle and Pitch Curve:** After the needle valves are adjusted the model can be trimmed for hover. The throttle curve should be adjusted so that the model is almost to the hover head speed just above quarter stick. This helps the model lift off smoothly and also allows you to do slow vertical descents without the engine dropping out. The throttle curve above half stick should also be adjusted so that slow vertical ascents can be made without the engine speeding up or slowing down. Simultaneously adjust the hover pitch and hover throttle for the head speed you want to hover at, also ensure that the model is hovering at half stick. Next adjust the high and low side of the normal pitch curve until the model has the collective response you want in a hover.

**NOTE:** Try to maintain original hovering recommended pitch settings. Flight trim for fine tuning once engine settings have been achieved. Fine tune low pitch settings for aerobatic maneuvers desired. Fine tune high pitch settings to match performance level of engine used.

C. **Tail Rotor Trimming:** Adjust tail rotor trimming as needed by moving transmitter until a stabilized tail is achieved. Re-center trimmer and adjust tail rotor control rod clevises until tail stabilizes with trimmer in neutral.

D. **Tail Rotor Compensation:** With the model in a trimmed stationary hover adjust the top tailrotor compensation so that the nose of the model stays straight. Starting at a height of fifteen to twenty feet,

descend and watch for the nose of model to change direction or drift to one side or the other. Adjust lower tail comps to correct this. **NOTE:** The speed that you ascend and descend should be as slow as a FAI pilot might ascend and descend his heli while performing a top hat maneuver.

- E. Swashplate Trimming: When the helicopter drifts to the left or the right, adjust aileron transmitter trimmer until stabilized. Re-center trimmer and adjust lower swashplate aileron rods until stabilized again. Repeat same process for fore and aft (elevator) control.

Gyro:

- F. If you are using a dual rate gyro adjust the high rate for hovering as high as it will go without oscillation of the tail once you get the model flying in forward flight. Adjust the gyro on the low rate as high as it will go without the tailrotor oscillating.
- G. Main Rotor Blade Tracking: The tracking of the main rotor blades may be checked just prior to lift-off. Be sure to maintain a safe distance from your machine. The adjustments can be made by changing the length of the Hiller Rods, #0335, on each side of the head. A piece of colored tape must be applied to one blade during balancing in order to determine which blade is high or low. Tracking procedure:
- Blade speed is low, lower the higher blade
  - Blade speed is high, raise the higher blade
  - If blades are out an inch or better, re-check original bench pitch settings
- H. Top Pitch: Adjust the top end pitch on your idle up functions so that the model will fly at full throttle without losing head speed. A model with too much top end pitch tends to be "pitchy" and unstable.

*We wish you good luck and many happy hours of flying!  
If you have any further questions, feel free to call us.*

*The staff at Miniature Aircraft USA would like to express their appreciation to Tim Schoonard and Paul Bittenge for their time and dedication in the creation and final production of the X-Cell Standard .60 Instruction Manual.*

## MINIATURE AIRCRAFT USA

3743 SILVER STAR ROAD  
ORLANDO, FLORIDA 32808  
U.S.A.

PHONE (407) 292-4267  
FAX (407) 292-4296



## SPECIAL NOTICE

### XL-SERIES HELICOPTERS VERSES DUAL-TAIL USAGE

Subject: A). #0541 and 0541-1 High Performance Dual FAI Tail Rotor System.

B). #1006 XL-PRO and #1007 Optima XL-PRO.

C.) #0547 High Speed Tail Gear .30, .40, .50 and .60 size.

- 1). If the customer purchases a 0541 & 0541-1 Dual Tail Rotor System for installation on a XL-PRO .60 Graphite FAI Helicopter Kit #1006 or Optima XL-PRO .60 Graphite FAI Kit #1007, the customer is required to purchase (2) #0427 Tail-Rotor Beveled gears for proper operation and installation.
- 2). If the customer purchased #0547 High Speed Tail Rotor gear kit for X-Cell .30, .40, .50 and .60's and decides to install a #0541 or #0541-1 Dual-Tail Rotor System, the customer is required to re-install the #0427 Tail-Rotor gears supplied with the kit or purchase (2) #0427 replacement parts.

### Common Solution to Tracking Problems on X-Cell 50, 60 Series Helicopters

- **Probable Cause** -

Thrust bearing limited by Loctite contamination.

Solution - Apply loctite inside axle hole rather than on bolt. Use very small amount and allow at least 1 hour cure prior to use.

- **Probable Cause** -

Thrust bearing is notchy from a contamination of dirt and or crash. Since thrust bearings cannot be properly checked without operational loads it is best to not reuse them after a crash or extended operation. (Avg. use 1 year)

Solution - Replace units as per manual.

- **Probable Cause** -

Thrust bearing installed backwards.

Solution - Always be sure that the load bearing side be nearest the bearing bolt. In other words, the larger I.D. side goes nearest the head block. Carefully reassemble in correct orientation.

- **Probable Cause** -

Thrust bearing bound-up on head axle. This inhibits correct thrust bearing operation as blade loads vary.

Solution - Do not overtighten axle bolts. This will cause the ends of the axle to "Swell" or "Roll" slightly limiting the thrust bearing. This is noticeable when the thrust bearing will not easily slide off the axle. Prior to replacement, the axle should be replaced.

- **Probable Cause** -

Main axle bent causing intermittent tracking problem as the axle tries to rotate slightly within the head block.

Solution - Replace axle.

- **Probable Cause** -

Bell mixers are not uniformly installed. This can be either a mixer reversed on the pivot bolts or rotated so that dissimilar length control balls connect to the hiller rods on each side of the head.

Solution - Carefully study the instruction manual and the appearance of the mixers on the rotorhead. Each mixer has a "stepped" area surrounding one bearing. This "step" should always face the pitch arm portion of the blade holder also, the short control ball #0109 must always connect to the long hiller rods and not the short flybar yoke rods.

- **Probable Cause** -

Blade pivot bolts are too loose. Due to slight variations in blade cordwise C.G. and the oscillation state in which the blades function during pitch changes, it is suggested that the pivot bolt be used as a "shock absorber" to hinder exaggerated blade oscillation.

Solution - Tighten blade pivot bolts until the blades are very snug within the mounts - commonly, this would mean that by holding the blade and the flybar, and pivoting the blade the flybar would deflect at least 2" prior to blade movement. 9 out of 10 modelers set this up far too loosely.

- **Probable Cause** -

Improperly assembled blade reinforcement causing considerable difference in one hiller rod and the other to achieve tracking.

Solution - Replace blades and study the assembly procedures carefully prior to assembly.

- **Probable Cause** -

Blade spanwise C.G. not matched.

Solution - It is most important that the spanwise C.G. be exactly matched prior to covering and that the blades have the same total weight.

<u>NO.</u>	<u>I.D.</u>	<u>O.D.</u>	<u>NO.</u>	<u>SIZE</u>	<u>NO.</u>	<u>SIZE</u>	<u>NO.</u>	<u>SIZE</u>
0001	2.0x5.0		0025	2.2X6.5			0015	M2
0003	3.0x9.0		0027	2.2X9.5			0017	M3
0273	6.5x8.5		0029	2.2X13			0019	M3
0009	3.0x7.0		0035	2.2X14			0021	M4
0327	5.0x10.0		0051	M3X3			0041	M2X8
0007	6.6x12.3		0053	M3X5			0043	M2X10
0005	7.4x14.0		0054	M4X6			0045	M2X14
0213	6.2x12.9		0057	M4X4			0047	M2X16
0329	8.0x13.0x.25		0033	M3X5			0061	M3X8
0331	8.0x13.0x.50		0031	2.9X6.5			0063	M3X10
0325	10.0x15.8		0034	2.9X13.0			0065	M3X12
0161	3.0x11.7		0089	M3X10			0067	M3X14
0225	2x13.7		0093	M3X15			0069	M3X16
0451	2x17.7		0095	M3X19			0091	M3X16
0297	2.5x24		0097	M3X22			0071	M3X18
			0099	M3X30			0073	M3X20
			0081	M4X16			0075	M3X25
			0083	M4X35			0077	M3X30
			0085	M5X16			0079	M3X35

M1:1