

X-CELL
Fury
Extreme



**XCell Fury Extreme
Assembly Manual**

Version 1.0

For More Information contact:

Miniature Aircraft USA

31713 Long Acres Drive
Sorrento, FL 32776 USA

Phone 352-383-3201

Fax 352-383-3204

Email: minair@miniatureaircraftusa.com

Table Of Contents

REVISIONS TO THIS MANUAL	6
ERRATA	6
I. KIT INTRODUCTION	7
R/C HELICOPTER SAFETY	7
GUIDELINES FOR SAFE R/C HELICOPTER FLIGHT	7
X-CELL LIMITED WARRANTY.....	8
WARRANTY PROCEDURES.....	8
X-CELL EXTREME WARRANTY REGISTRATION.....	8
II. KIT PREREQUISITES	9
SUPPLIES NEEDED FOR ASSEMBLY	9
<i>Adhesives Used</i>	9
TOOLS NEEDED FOR ASSEMBLY	10
ADDITIONAL COMPONENTS NEEDED.....	11
III. KIT ASSEMBLY PROCESS	13
ASSEMBLY TIPS.....	13
FASTENER GUIDE.....	13
STEP #1 – GEAR RATIOS	15
A) <i>Gear Ratio - Bag #1A – Kit Specific</i>	15
8:18 Ratio.....	15
8:45 Ratio.....	16
STEP #2 – LEFT FRAME	17
A) <i>Main Frame Components - Bag #2A</i>	17
B) <i>Frame Fasteners - Bag #2B</i>	18
2B.1 – Assemble Left Frame – Part 1	19
2B.2 – Assemble Left Frame – Part 2	21
C) <i>Drive Train Components - Bag #2C</i>	23
2C.1 – Install Drive Train Components.....	24
D) <i>Constant Drive - Bag #2D</i>	26
2D.1 - Assemble Constant Drive Unit.....	27
2D.2 – Install Main Shaft/Collars.....	29
2D.3 – Install Constant Drive	30
2D.4 – Install Left Gear Ratio Plate.....	31
E) <i>Clutch Assembly - Bag #2E</i>	32
2E.1 - Assemble Clutch	33
2E.2 - Install Clutch Assembly.....	34
STEP #3 – RIGHT FRAME	37
A) <i>Right Frame - Bag #3A</i>	37
B) <i>Right Frame Components - Bag #3B</i>	38
3B.1 – Assemble Right Frame.....	39
3B.2 – Install Right Frame.....	41
3B.3 - Install Right Ratio Plate.....	43
3B.4 – Install Landing Gear Mounts	45
C) <i>Control Bellcranks - Bag #3C</i>	46
3C.1 – Assemble Aileron/Pitch Bellcranks.....	47
3C.2 – Install Aileron/Pitch Bellcranks.....	48
3C.3 - Assemble Elevator Bellcrank.....	49
3C.4 - Install Elevator Bellcrank.....	50

XCell Fury Extreme Assembly Manual

3C.5 - Assemble Rudder Bellcrank.....	51
3C.6 - Install Rudder Bellcrank.....	52
STEP #4 – FRAME ASSEMBLY.....	53
A) Chassis Components - Bag #4A.....	53
B) Engine Components - Bag #4B.....	54
4B.1 – Prepare Engine.....	55
4B.2 – Install Engine Mounts.....	57
4B.3 – Install Engine.....	59
C) Landing Gear - Bag #4C.....	60
4C.1 – Assemble/Install Landing Gear/Frame Bottom Plate.....	60
D) Fan Shroud Mounts - Bag #4D.....	62
4D.2 – Assemble/Install Fan Shroud/Mounts.....	63
4D.3 – Install Muffler.....	64
STEP #5 – FUEL TANK.....	67
A) Fuel Tank - Bag 5A.....	67
5A.1 - Assemble Fuel Tank.....	68
5A.2 - Install Fuel Tank.....	70
STEP #6 – SWASHPLATE/WASHOUT MIXER.....	71
A) Swashplate - Bag #6A – Kit Specific.....	71
6A.1 - Assemble Swashplate.....	72
6A.2 - Install Swashplate – 140° Kit.....	74
B) Washout Mixer - Bag #6B.....	75
6B.1 - Assemble Washout Mixer.....	76
6B.2 - Install Washout Mixer.....	78
6B.3 – Assemble Swashplate Control Rods.....	79
6B.4 – Install Swashplate Control Rods.....	79
STEP #7 – CONTROL SYSTEM/CANOPY.....	80
A) Servo Mounts - Bag #7A.....	80
7A.1 – Install Servos/Radio Gear.....	81
B) Ball Links - Bag #7B.....	84
C) Control Rods - Bag #7C.....	85
7C.1 – Assemble Servo Control Rods.....	85
D) Servo Supports - Bag #7D.....	87
7D.1 – Assemble/Install Servo Wheels.....	88
7D.2 – Install Servo Control Rods.....	90
7D.3 – Install Servo Supports.....	91
E) Canopy Mounts - Bag #7E.....	92
7E.1 – Assemble Canopy Knobs.....	92
F) Canopy – Box Contents.....	93
7F.1 – Prepare Canopy.....	94
STEP #8 – ROTOR HEAD.....	95
A) Head Block - Bag #8A.....	95
8A.1 - Head Block Assembly.....	96
B) Blade Grips - Step #8B.....	97
8B.1 – Assemble Bell Mixer.....	98
8B.2 – Install Bell Mixers.....	99
C) Head Axle Components - Bag #8C.....	100
8C.1 - Blade Arm Assembly.....	101
8C.1 – Assemble Blade Arms.....	101
8C.2 – Install Blade Arms.....	103
D) Flybar - Bag #8D.....	104
8D.1 – Assemble/Install Flybar Control System.....	105
8D.2 – Assemble/Install Flybar Bell Links.....	106
8D.3 – Install Flybar.....	107
8D.4 – Install Flybar Paddles.....	107
8D.5 – Install Rotor Head.....	108

XCell Fury Extreme Assembly Manual

STEP #9 – TAIL ROTOR ASSEMBLY	109
A) <i>Tail Rotor Hub - Bag #9A</i>	109
9A.1 – Assemble Tail Rotor Hub	110
9A.2 – Install Tail Rotor Blades.....	112
B) <i>Tail Rotor Pitch Yoke - Bag #9B</i>	113
9B.1 – Assemble TR Pitch Yoke.....	114
C) <i>Tail Rotor Transmission - Bag #9C</i>	116
9C.1 – Assemble T/R BellCrank	117
9C.2 – Install T/R BellCrank.....	118
9C.3 – Install T/R Pitch Yoke	119
STEP #10 – LOCATE TAIL BOOM COMPONENTS	120
A) <i>Tail Boom Components - Bag #10</i>	120
STEP #11 – TAIL BOOM ASSEMBLY	121
A) <i>Tail Boom Mounts - Bag #11A</i>	121
11A.2 – Install T/R Transmission	122
11A.3 – Install Vertical Fin Mount/Fin	123
11A.4 – Install Horizontal Fin Mount/Fin	125
11A.5 – Install Tail Rotor.....	127
11A.6 – Install Front Tail Boom Mount.....	128
B) <i>Tail Rotor Pushrod Components - Bag #11B</i>	129
11B.1 – Assemble/Install T/R Pushrod Guide.....	130
11B.2 – Install Tailboom.....	130
11B.3 – Assemble T/R Pushrod.....	131
11B.4 – Install T/R Pushrod.....	132
C) <i>Tail Boom Support Components - Bag #11C</i>	133
11C.1 – Assemble Tail Boom Supports	133
11C.2 – Install Tail Boom Supports.....	134
11C.3 – Install Rotor Blades.....	135
11C.4 – Install Canopy.....	135

Revisions to this Manual

R1.0

- 10/01/06 – Revisions for final kitting modifications
- 11/10/06 – Revisions to main rotor blade arm bearing order

For the most current version of this manual, please refer to www.miniatureaircraftusa.com, visit the Extreme helicopter kit and download the assembly manual

Errata

I. Kit Introduction

R/C Helicopter Safety

A radio controlled model helicopter is a technically complex device that must be built and operated with care. It is also a fascinating and challenging part of the R/C sport, the mastery of which is very rewarding.

A model helicopter must be built exactly in accordance with the building instructions. The kit manufacturer has spent much time and effort refining his product to make it reliable in operation and easy to build. The essentially bolt together construction can proceed quite rapidly, giving the builder a strong sense of accomplishment that encourages hasty progress from one construction phase to the next, so that the completed model can be more quickly seen and enjoyed. It is essential to recognize and guard against this tendency. Follow building instructions exactly. Vibration and stress levels are high and all fasteners and attachments must be secure for safe operation.

Note that this is the first use of the word SAFETY in these comments. Previously the kit manufacturer's efforts to ensure reliable operation were mentioned. That is ALL that he can do. Safe operation is the responsibility of the builder/flyer and starts with careful construction and continues with selection and installation of reliable radio equipment and engine.

The need for safety is nowhere greater than at the flying field. A number of guidelines for safe flight have been developed by experienced flyers and are set down here. It is urged that they be read, understood and followed.

Guidelines for Safe R/C Helicopter Flight

- Fly only at approved flying fields and obey field regulations.
- Follow frequency control procedures. Interference can be dangerous to all.
- Know your radio. Check all transmitter functions before each flight.
- Be aware that rotating blades are very dangerous and can cause serious injury.
- Never fly near or above spectators or other modelers.
- If a beginner, get help trimming the model first and flight training later.
- Don't "track" the main blades by holding the tail boom. This is a temptation to builders who cannot hover yet and is very dangerous.
- Follow all recommended maintenance procedures for model, radio and engine.

WARNING!

This helicopter is not a toy, but a complex flying machine that must be assembled with care by a responsible individual. Failure to exert care in assembly, or radio or accessory installation, may result in a model incapable of safe flight or ground operation. Rotating components are an ever present danger and source of injury to operators and spectators. Since the manufacturer and his agents have no control over the proper assembly and operation of his products, no responsibility or liability can be assumed for their use.

X-CELL Limited Warranty

The warranty covers defects in material or workmanship or missing components to the original purchaser for 30 days from the date of purchase. Miniature Aircraft, USA will replace or repair, at our discretion, the defective or missing component. Defective components must be returned to us prior to replacement.

Any part, which has been improperly installed, abused, crash damaged or altered by unauthorized agencies, is not covered. Under no circumstances will the buyer be entitled to consequential or incidental damages. The components used in this kit are made from special materials designed for special applications and design strengths. We recommend that all replacement parts be original parts manufactured by Miniature Aircraft, USA, to ensure proper and safe operation of your model. Any part used which was manufactured by any firm other than Miniature Aircraft, USA, VOIDS all warranties of this product by Miniature Aircraft, USA.

Warranty Procedures

Mail all warranty information within 15 days of original purchase date. If service is required, send the component in question (if not missing) together with a photocopy of your bill of sale and an accurate description of the problem and part. Ship components fully insured and prepaid. Miniature Aircraft, USA is not responsible for any shipping damages. We will, at our discretion, notify you of any costs involved, or ship it COD. You are required to pay all postage, shipping and insurance charges.

X-Cell Extreme Warranty Registration

Please print or type, filling in the information listed below and mail immediately

Model No: _____ Serial No: _____ Price paid: _____

Owners name: _____ Age _____

Address: _____ Phone: _____

City: _____ State: _____ Zip: _____

Purchased from: _____

Dealer's address _____

Comments: _____

**MINIATURE AIRCRAFT USA
31713 Long Acres Drive
Sorrento, FL 32776 USA
Phone (352) 383-3201
FAX (352) 383-3204**

II. Kit Prerequisites

In order to assemble this kit, you will need a number of additional supplies and tools to ensure the best final result. They are as follows:

Supplies Needed for Assembly



Blue Thread Lock



Red Thread Lock



Green Thread Lock



Oil



Grease

Adhesives Used



Slow Cyanoacrylate



JB Weld

Tools Needed for Assembly



M5 Nut Driver
M5.5 Nut Driver
M7 Nut Driver
M4 Nut Driver

1.5mm allen driver
2.0mm allen driver
2.5mm allen driver
3.0mm allen driver

Needle Nose Pliers
Phillips Screwdriver #1
Flat Screwdriver 2.5mm
Razor Knife (Xacto)

8.0mm wrench
5.5mm wrench
4.0mm wrench

Additional Components Needed

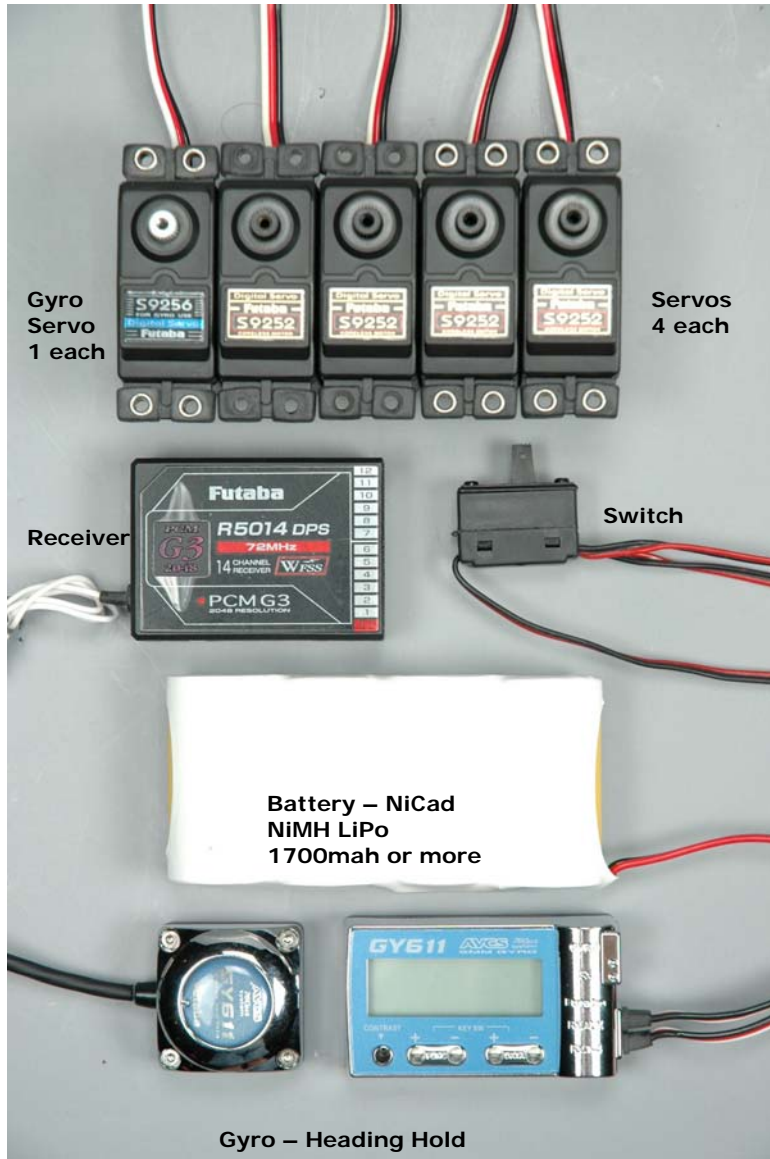

Motors:
OSMax .91SZH
YS .91ST4

XCell Fury Extreme Assembly Manual

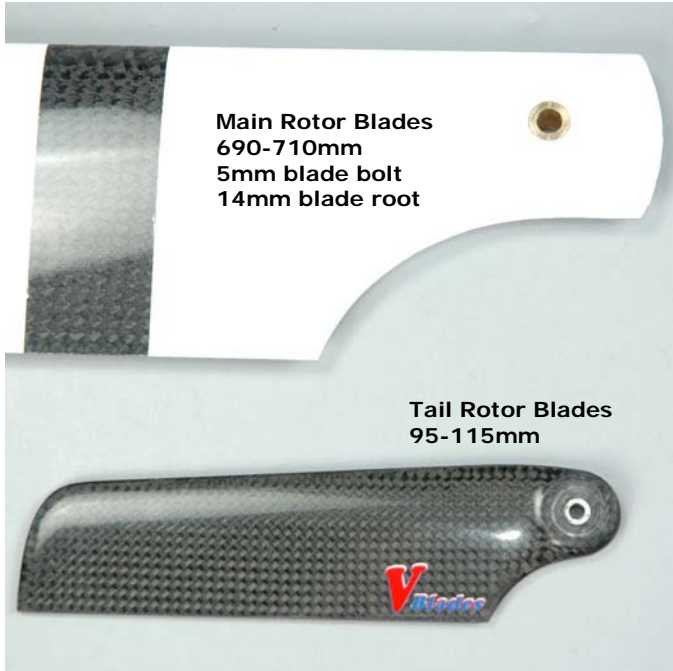

Mufflers:

Hatori SB16/SB17FH
Muscle Pipe/MP2

III. Kit Assembly Process

Assembly Tips



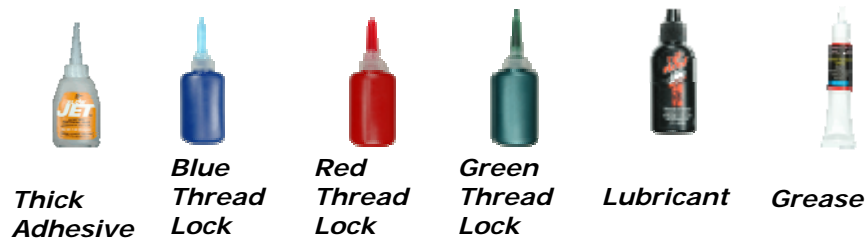







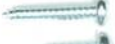























- Please note that this assembly manual consists of a photographic journal of the steps necessary to construct this helicopter. The builder is encouraged to pay close attention to the "building notes" and other details noted in the pictures and to carefully review all the photo's in a given step. The placement of a given part may be better understood when viewing another view of the assembly.
- Follow the order of assembly. The instructions have been organized into major sections and have been developed in such a way that each step builds upon the work done in the previous step. Changing the order of assembly may result in unnecessary steps
- The photos in this manual are organized within each step to correspond with the order of assembly. The sequence of the photos within a step is from top to bottom and from left to right.
- Clean all metal parts: All of the steel parts in this kit are coated with a lubricant to prevent them from rusting. This coating can interfere with the adhesives and thread locks needed for assembly. Use a solvent such as alcohol or acetone to clean the various metal parts, especially threads
- Use thread lock as indicated. Model helicopters are subject to vibration and failing to use thread lock on any non-locking assembly may result in a part becoming loose or falling off
- Sand sharp edges on any frame plate that Velcro® or wires may rub against to prevent them from being damaged over time by vibration
- Make sure every bearing runs smoothly after component assembly. If it does not find out why. A rough running bearing will fail prematurely.
- As a general rule any bolt that threads into a metal part should have thread lock applied and any screw or bolt that threads into a plastic part should have adhesive applied
- Assembly sections contain the following content:
 - The contents of each bag
 - An overview of part relationships
 - Assembly overview
- Photographs will contain assembly icons that indicate use of thread lock, adhesive or lubricant as needed. If an assembly has more than one of the same part number, application of thread lock, adhesive or lubricant will apply to all of the same numbered parts in that photograph Examples of the icons are as follows:

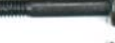

Fastener Guide

The next page contains a list of all of the threaded fasteners in this kit. They will print at actual size. If it is not clear what the part number of a fastener is, simply find the fastener on the chart and match its part number and description

XCell Fury Extreme Assembly Manual

Part #	Description	Actual Size
0027	M2.2 x 9.5 phillips screw -----	
0029	M2.2 x 13 phillips -----	
0032	M2.9 x 9.5 phillips screw -----	
0034	M2.9 x 9.5 phillips flat head screw --	
0038	M2.5 x 10 phillips bolts -----	
0039	M2.5 x 12 phillips bolt -----	
0043	M2 x 10 slotted bolt -----	
0048	M3.5 x 25 socket set screw -----	
0049	M2 x 10 socket bolt -----	
0051	M3 x 3 socket set screw -----	
0053	M3 x 5 socket set screw -----	
0053-5	M3 x 16 socket set screw -----	
0057	M4 x 4 socket set screw -----	
0058-1	M4 x 6 socket set screw -----	
0059-1	M2.5 x 6 socket bolt -----	
0060-1	M3 x 6 socket bolt -----	
0061	M3 x 8 socket bolt -----	
0063	M3 x 10 socket bolt -----	
0064	M3 x 8 button head -----	
0065	M3 x 12 socket bolt -----	
0067	M3 x 14 socket bolt -----	
0075	M3 x 25 socket bolt -----	
0077	M3 x 30 socket bolt -----	
0078	M4 x 12 socket bolt -----	
0079	M3 x 35 socket bolt -----	
0080	M4 x 14 socket bolt -----	
0081	M4 x 16 socket bolt -----	
0082-1	M5 blade bolt -----	
0086-1	M5 flanged bolt -----	
0088	M3 x 8 flat head bolt -----	
0088-2	M3 x 6 flat head bolt -----	
0089	M3 x 10 hex head bolt -----	
0093	M3 x 18 phillips bolt -----	
0097	M3 x 22 phillips bolt -----	
0064-3	M3 x 16 button head -----	

Step #1 – Gear Ratios

A) Gear Ratio - Bag #1A – Kit Specific

8:18 Ratio

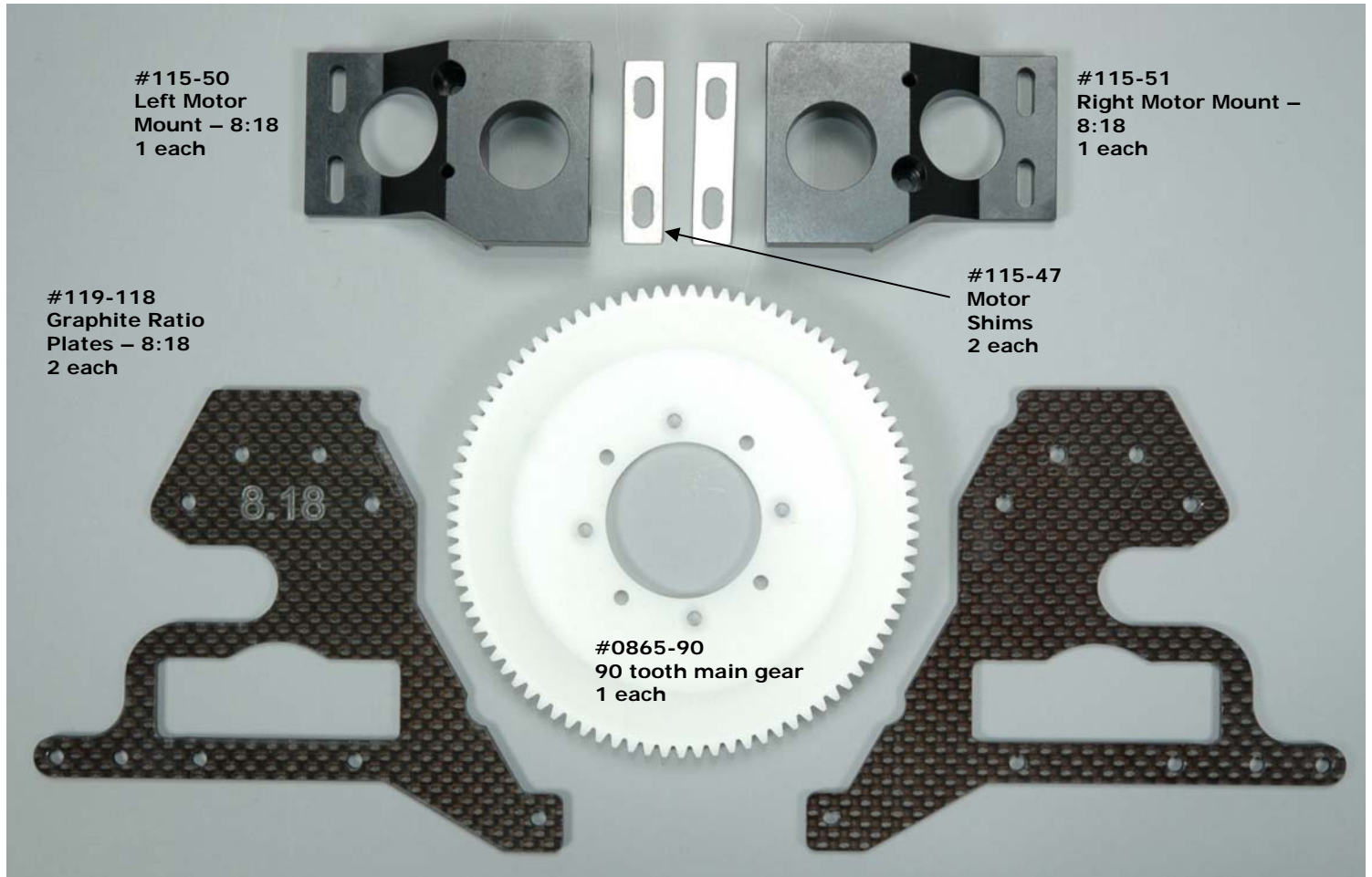

Building Notes – Locate Bag 1A. If you purchased the 8.18 kit it will contain parts specific to the 8.18 gear ratio. Verify that they are correct.

The gear ratio plates will be etched with the actual gear ratio and marked as left and right. Make sure that the marked ratio matches on both plates and that there is a left and right plate.

The motor mounts will have round holes machined in the wide part of the engine mount. If they are square, then the mounts are for the 8.45 kit. In addition, there will be two shims that go between the motor and the mounts.

The main gear in the 8.18 kit will contain 90 teeth.

Set these parts aside to be used in future steps.

XCell Fury Extreme Assembly Manual

8:45 Ratio

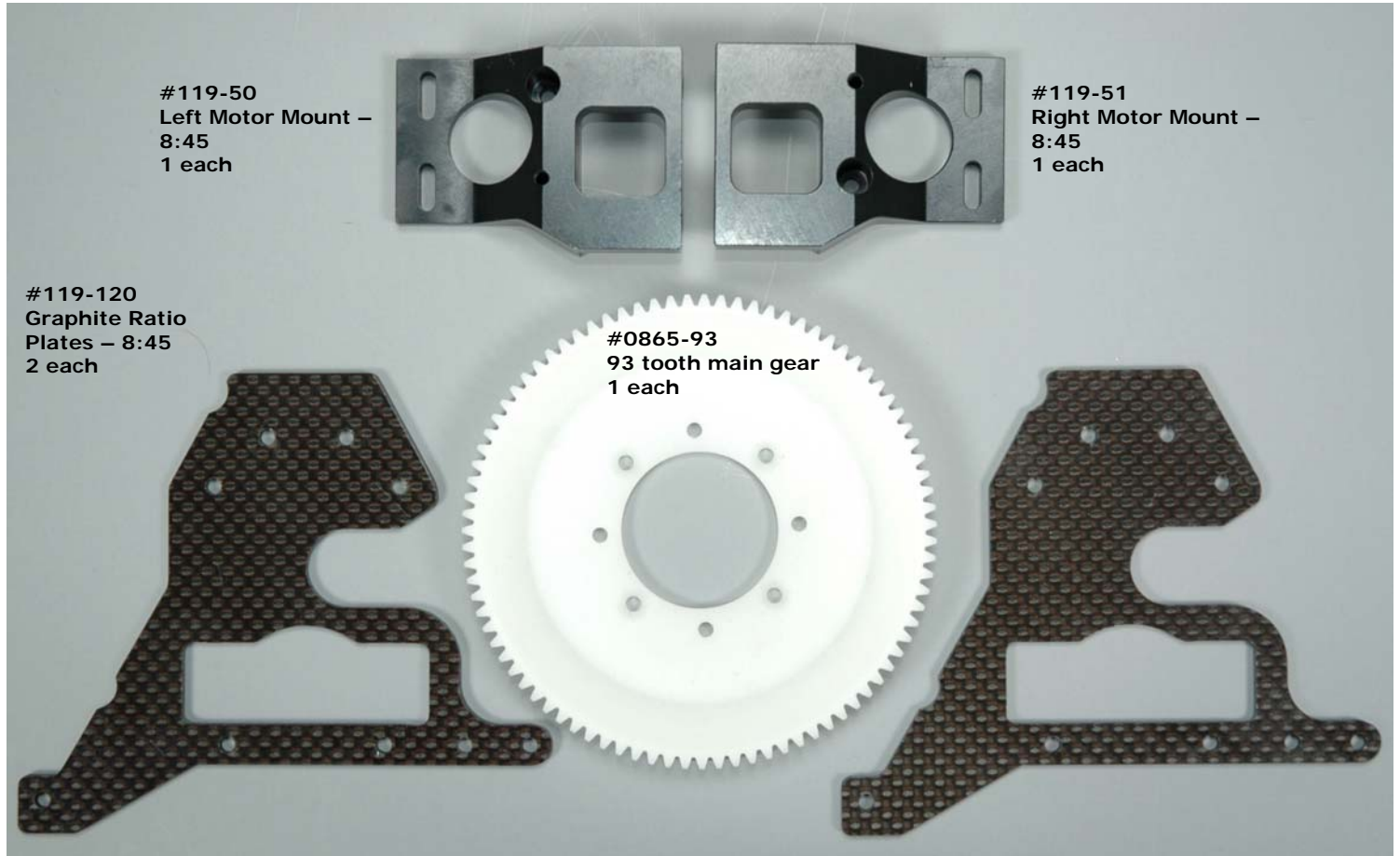

Building Notes – Locate Bag 1A. If you purchased the 8.45 kit it will contain parts specific to the 8.45 gear ratio. Verify that they are correct.

The gear ratio plates will be etched with the actual gear ratio and marked as left and right. Make sure that the marked ratio matches on both plates and that there is a left and right plate.

The motor mounts will have square holes machined in the wide part of the engine mount. If they are round, then the mounts are for the 8.18 kit. In addition, there will be two shims that go between the motor and the mounts.

The main gear in the 8.45 kit will contain 93 teeth.

Set these parts aside to be used in future steps.

Step #2 – Left Frame

A) Main Frame Components - Bag #2A

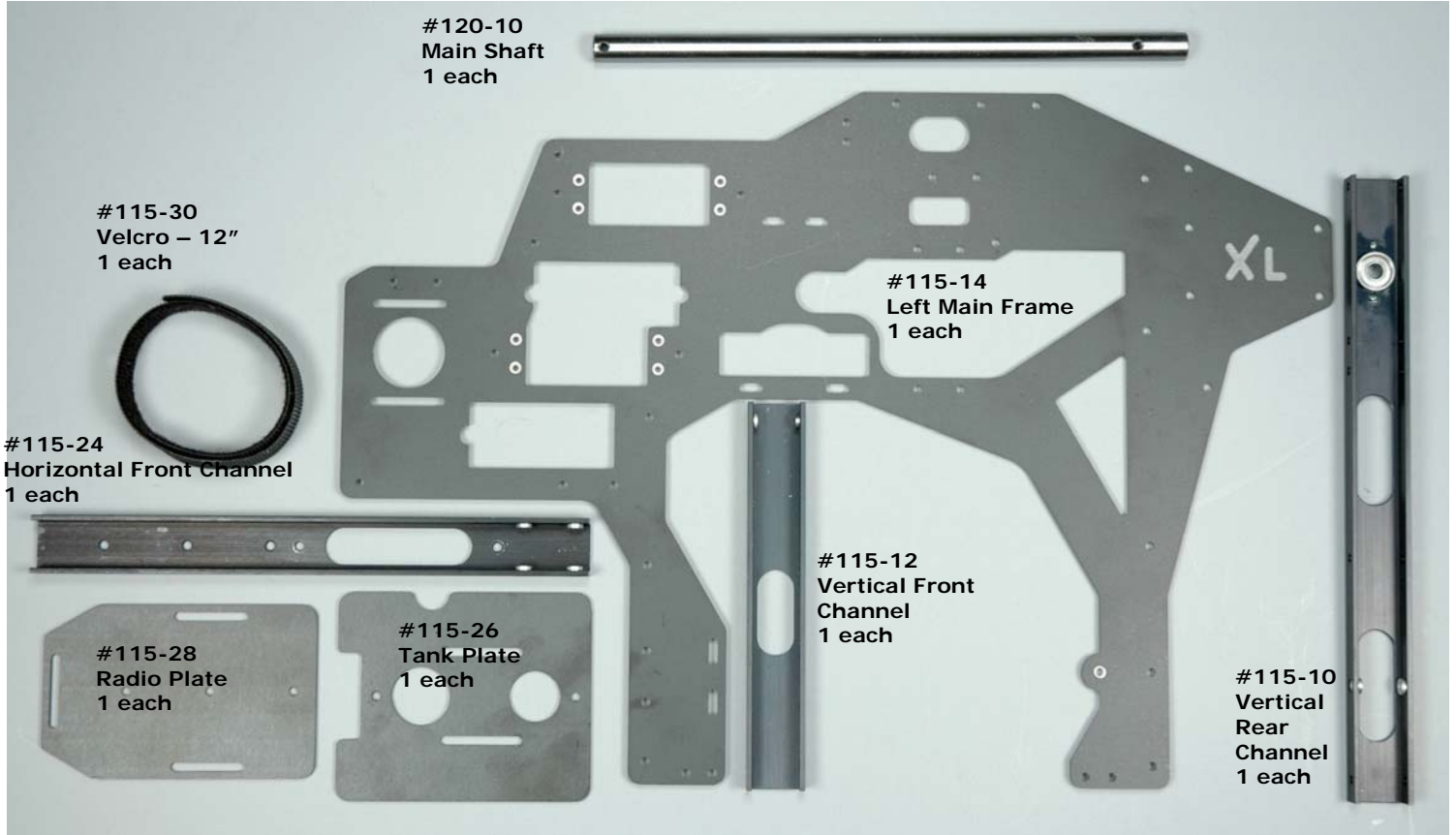

Building Notes – Locate Bag 2A which contains the major frame components for the left frame assembly

These parts will be used in the following steps.

B) Frame Fasteners - Bag #2B

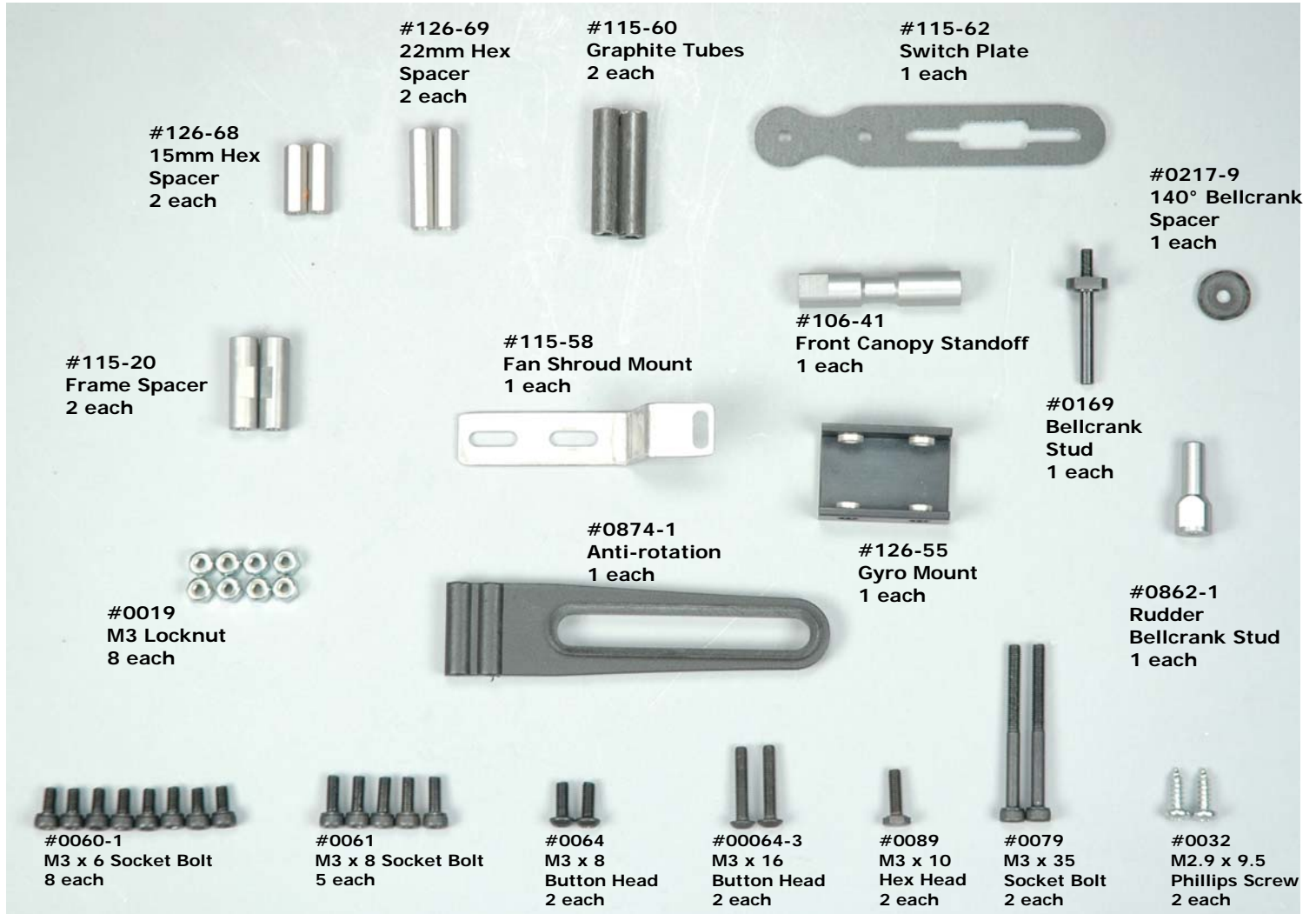

XCell Fury Extreme Assembly Manual

2B.1 – Assemble Left Frame – Part 1

Parts Relationship

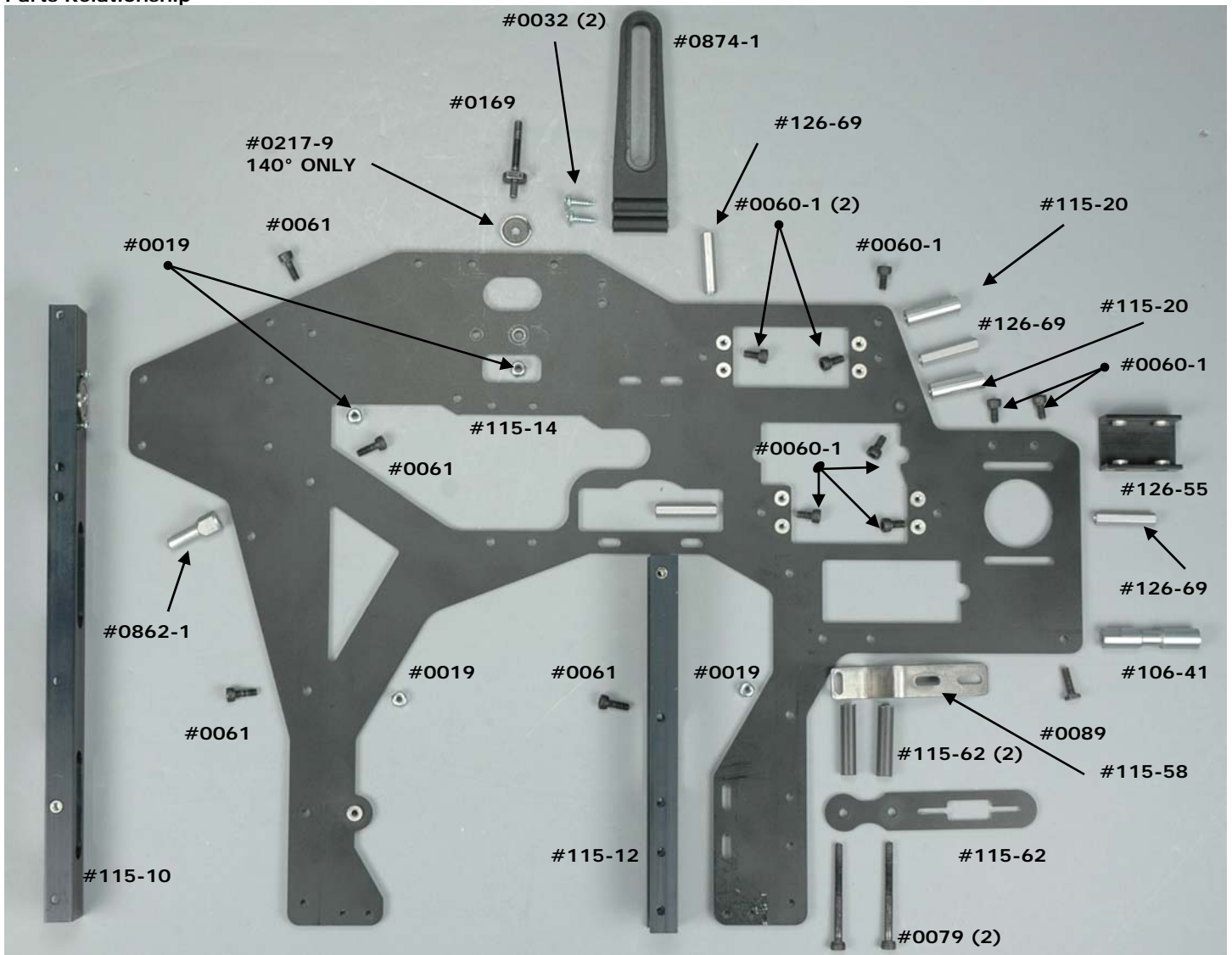

XCell Fury Extreme Assembly Manual

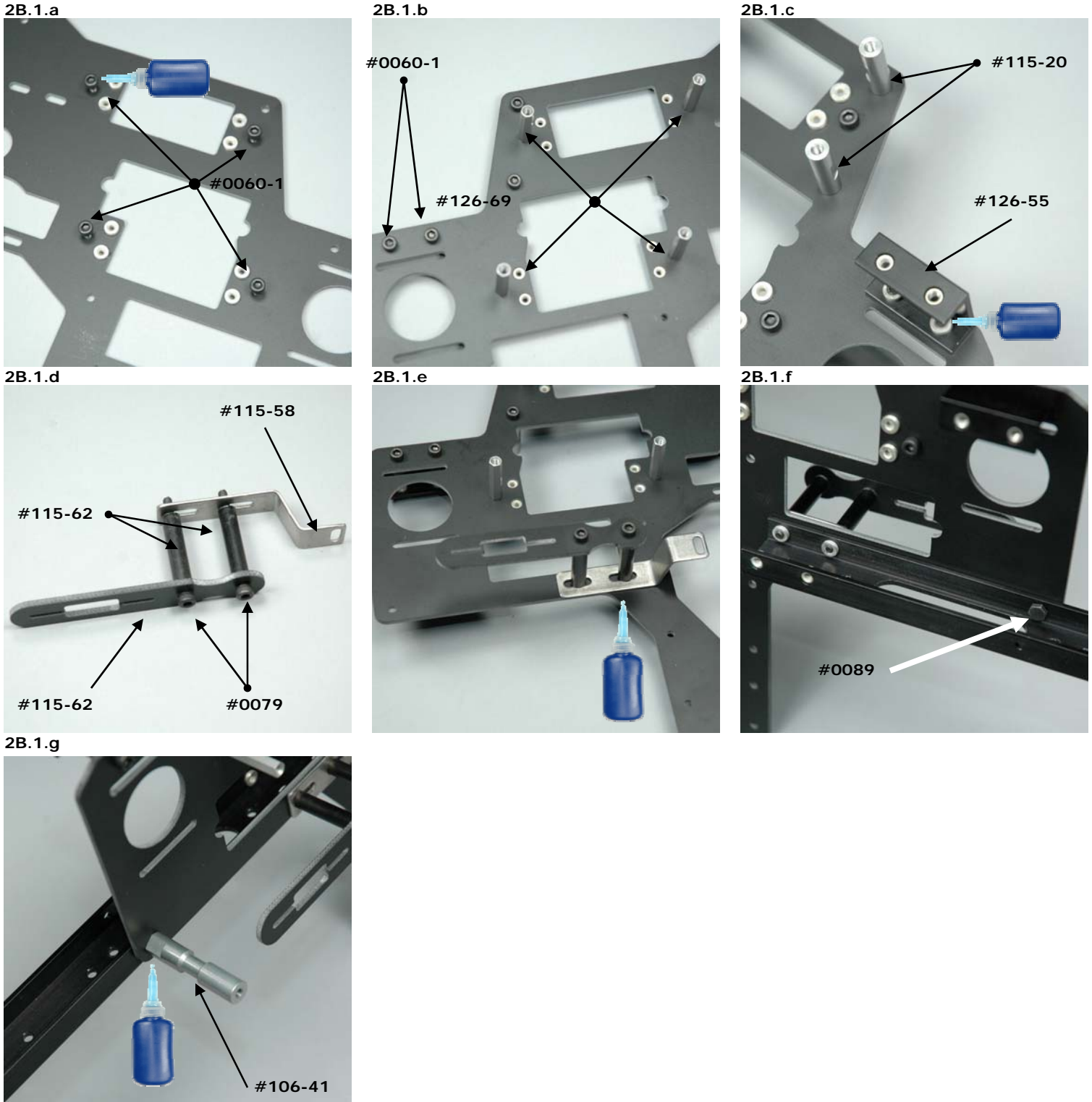

2B.2 – Assemble Left Frame – Part 2

Parts Relationship

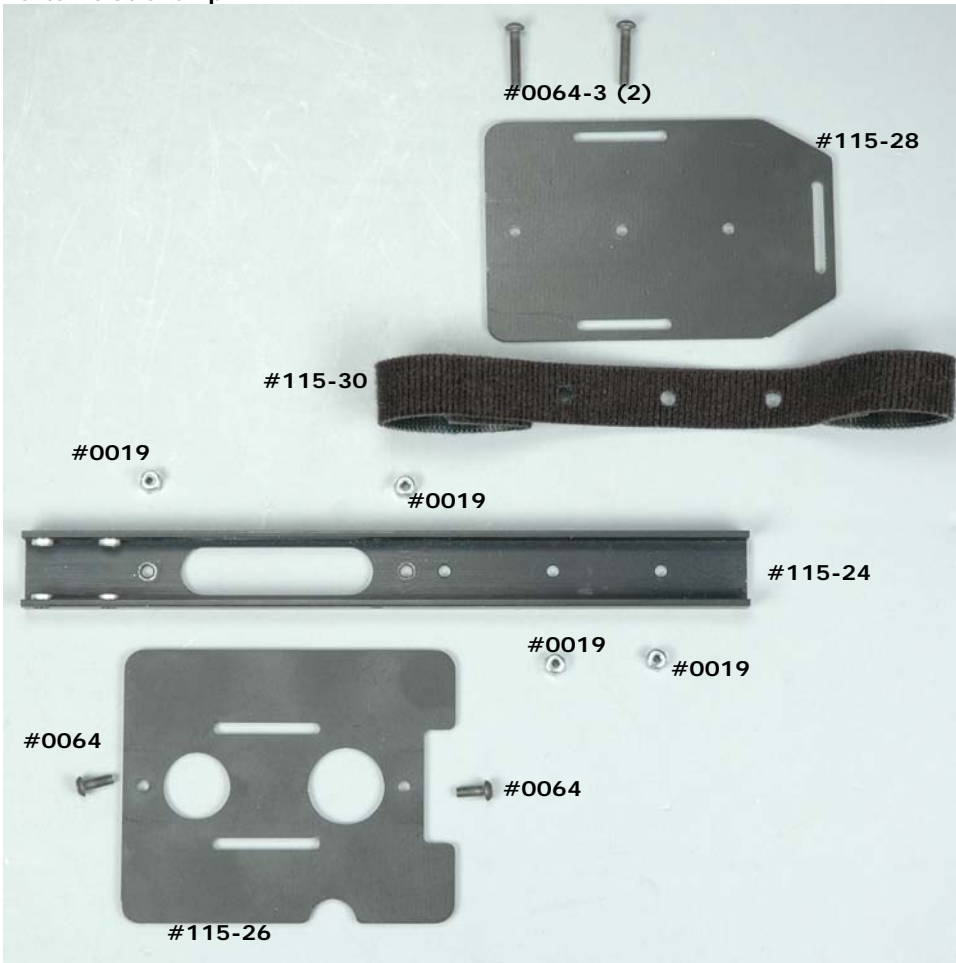

2B.2.a

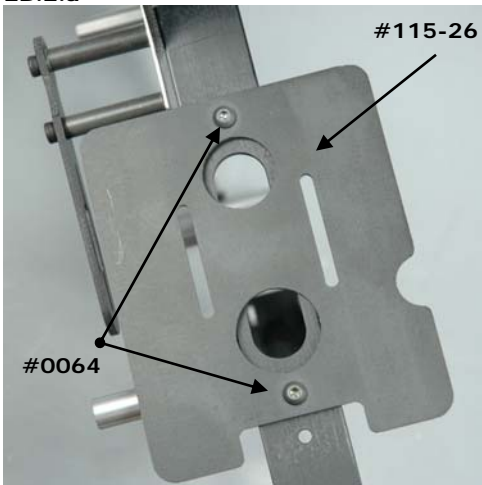

2B.2.b

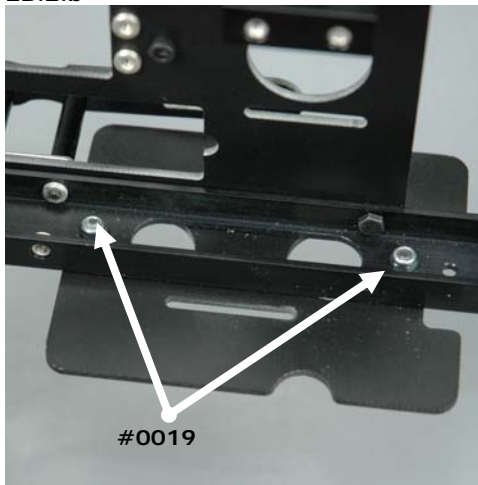

2B.2.c

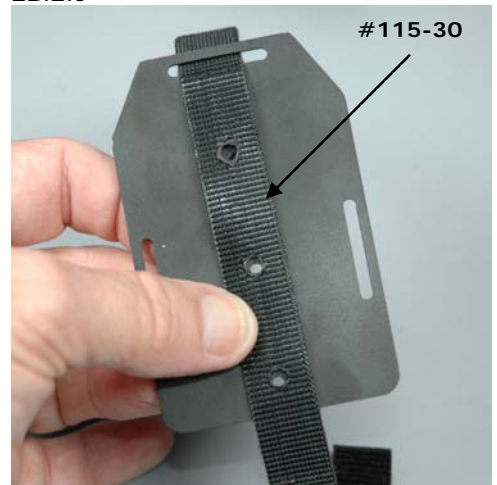

XCell Fury Extreme Assembly Manual

2B.2.d

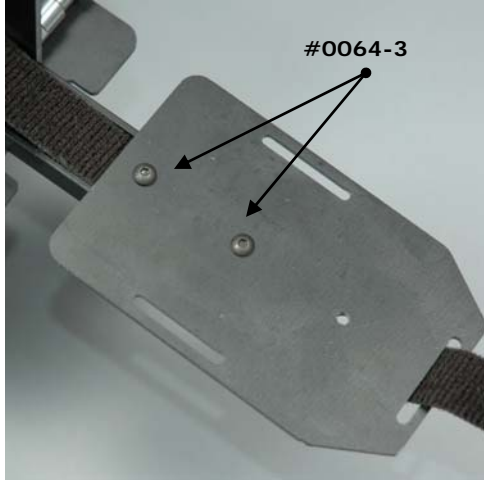

2B.2.e



2B.2.f

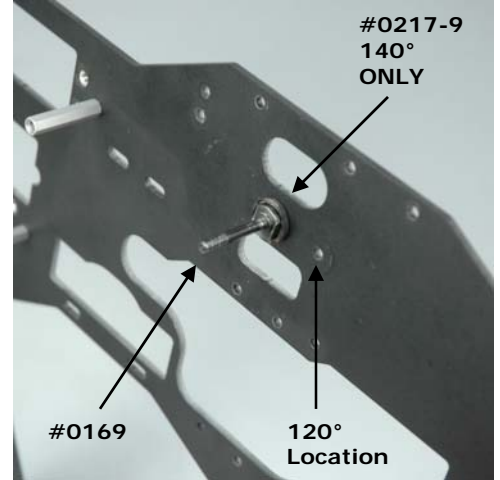

2B.2.G



2B.2.H

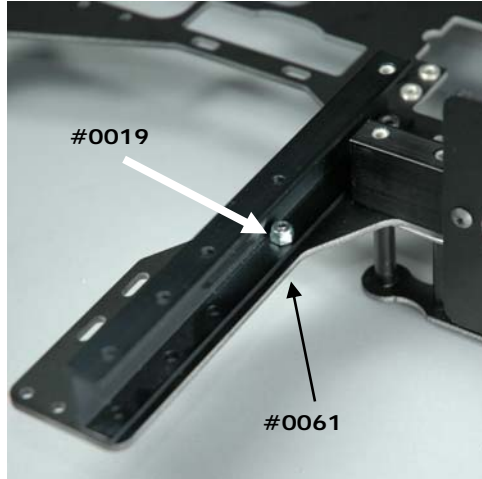

2B.2.I

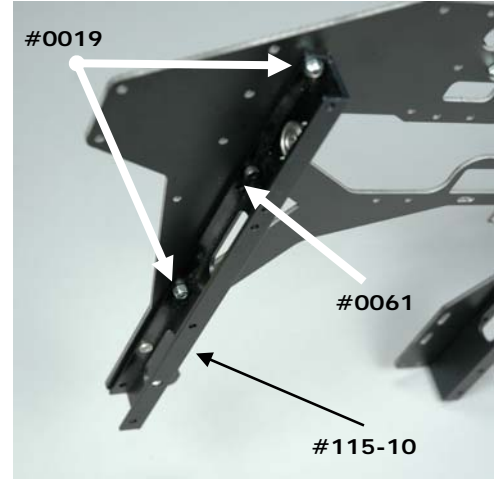

2B.2.J

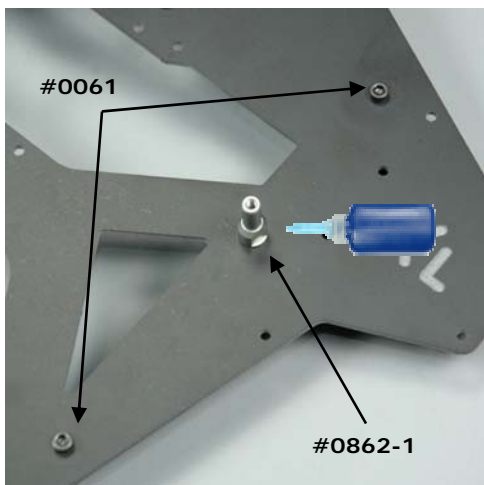

2B.2.K

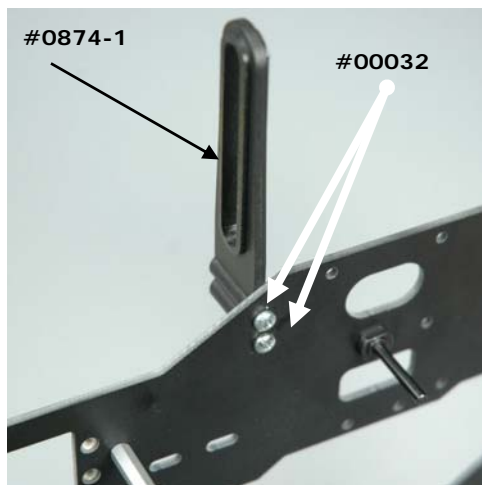

C) Drive Train Components - Bag #2C



2C.1 – Install Drive Train Components

Parts Relationship

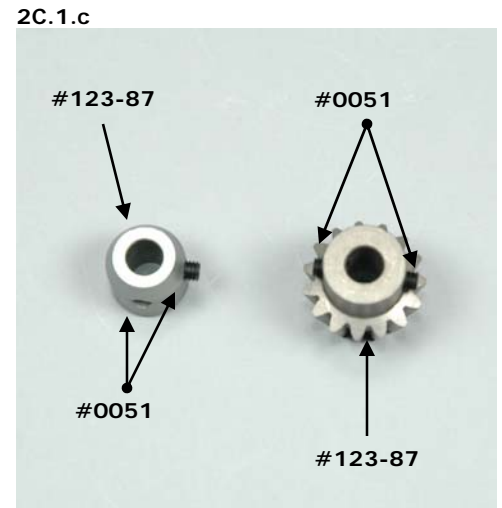
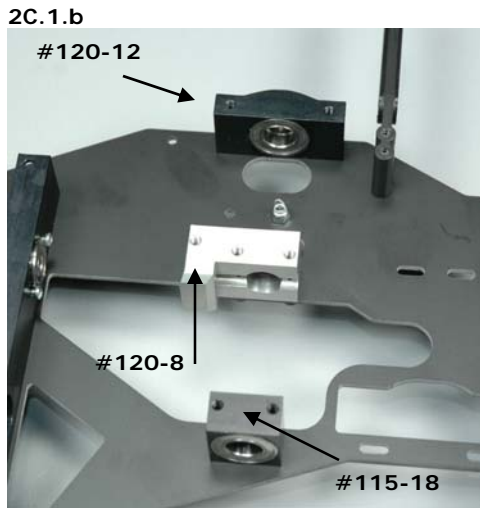
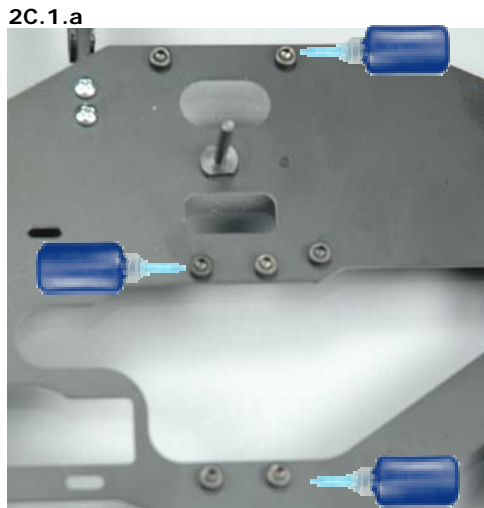
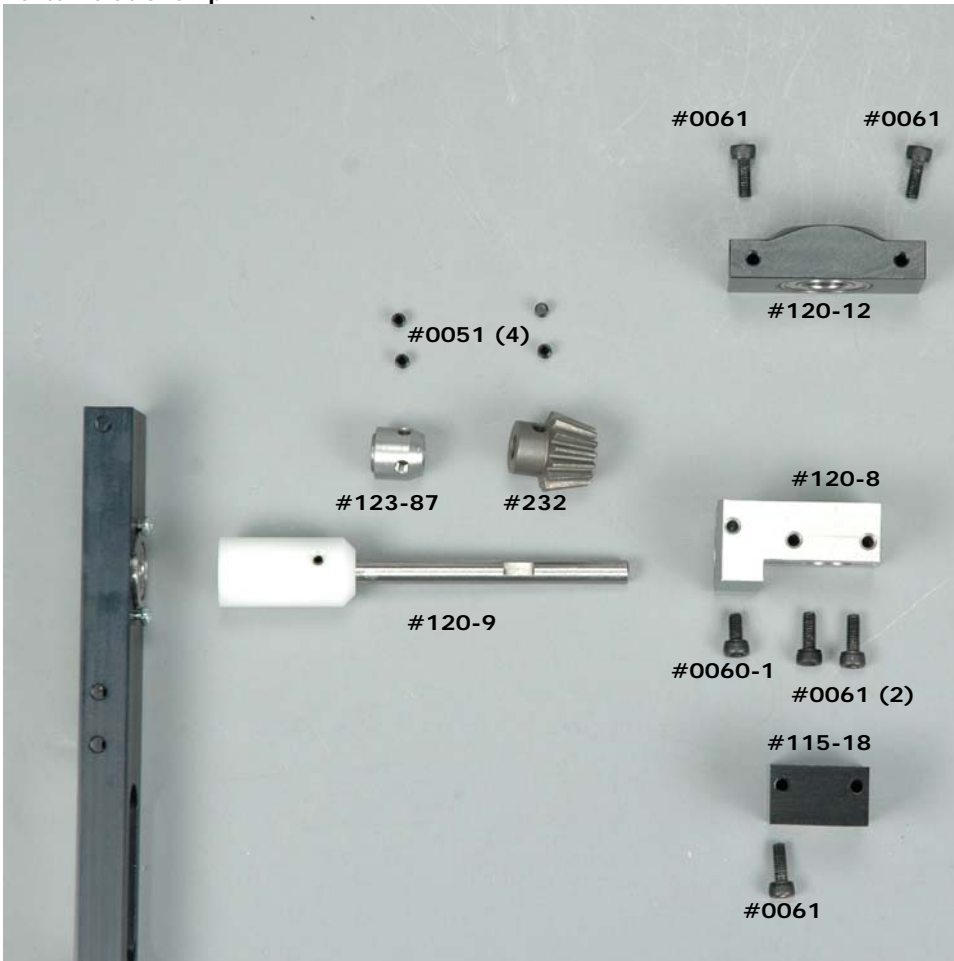

2C.1.d

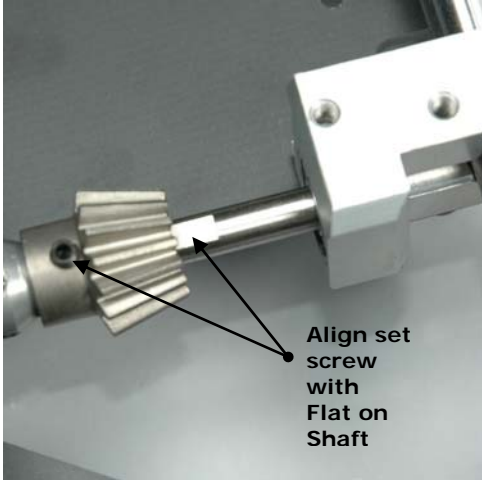

2C.1.e

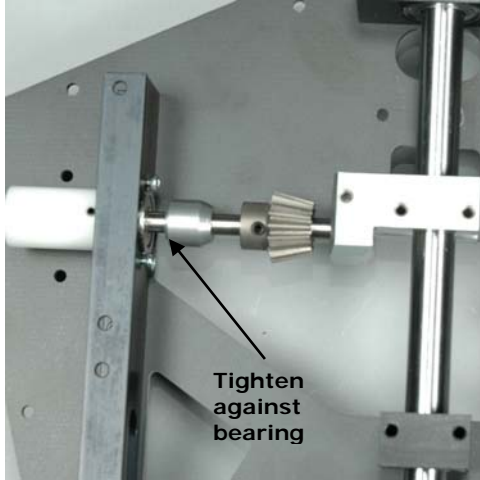

D) Constant Drive - Bag #2D

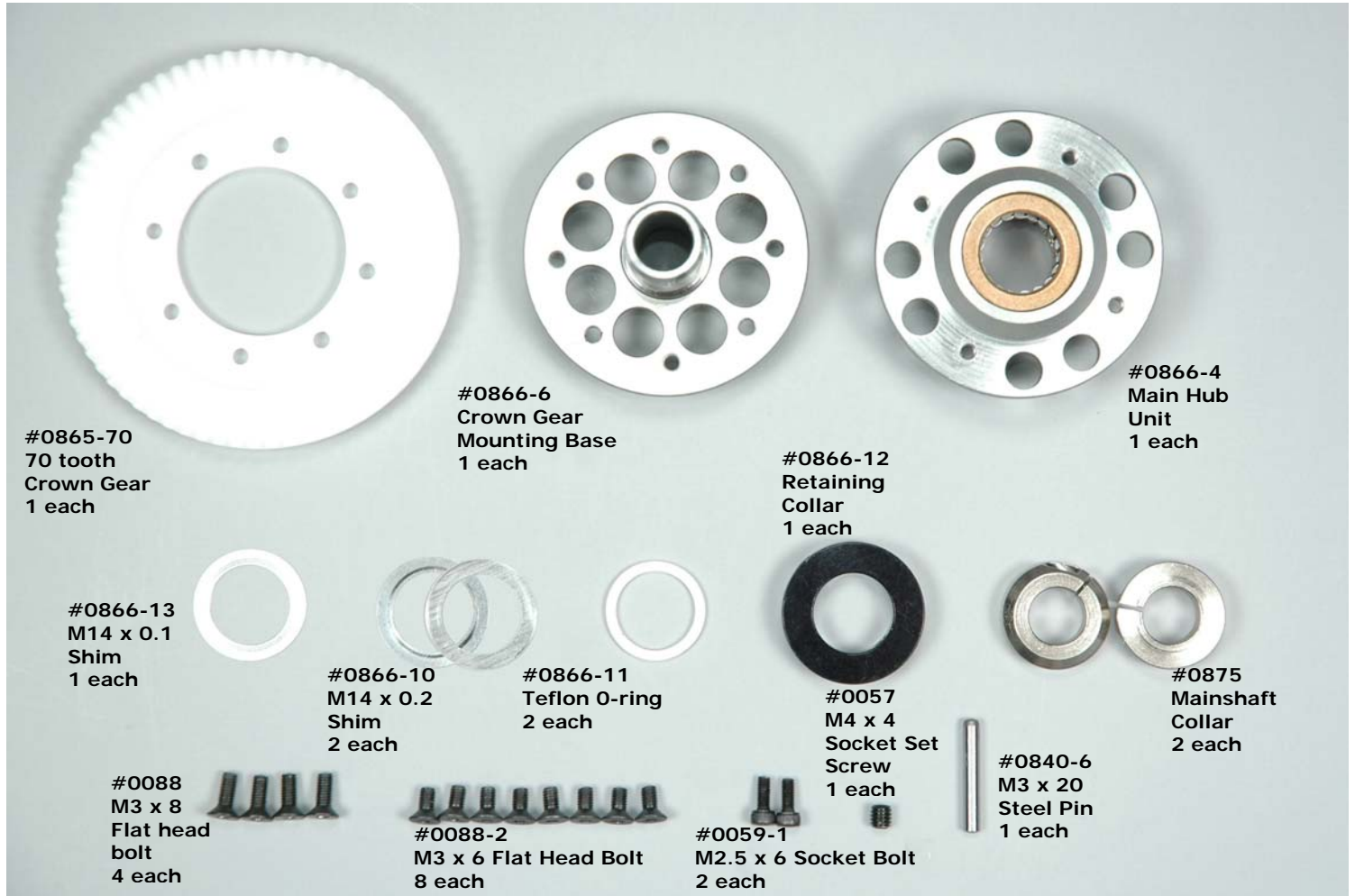

2D.1 - Assemble Constant Drive Unit

Parts Relationship

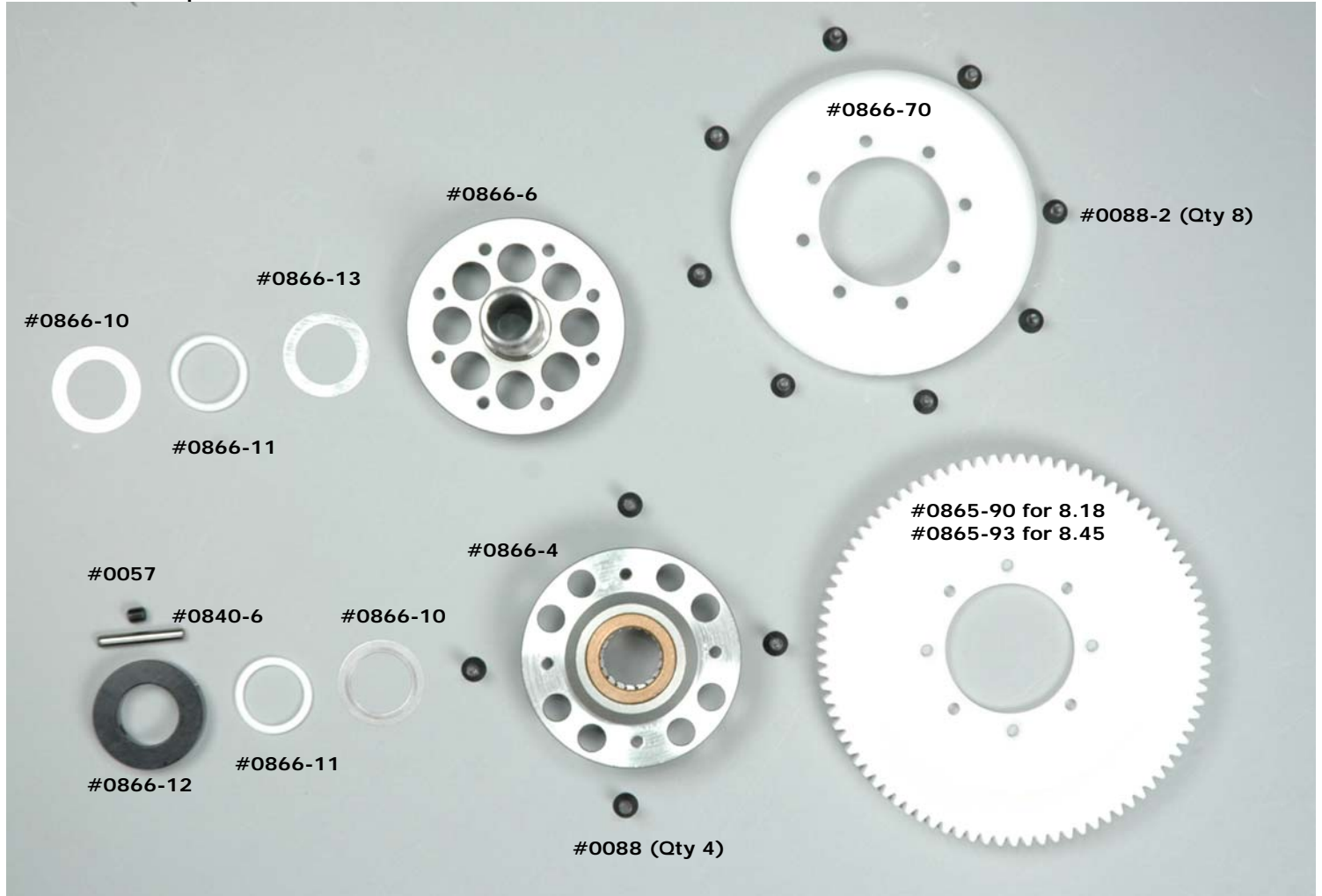

XCell Fury Extreme Assembly Manual

2D.1.a

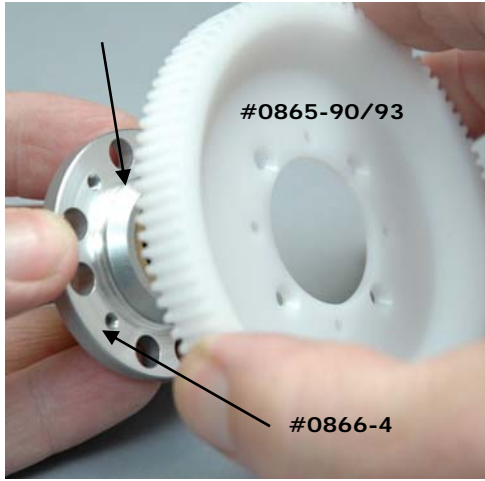

2D.1.b

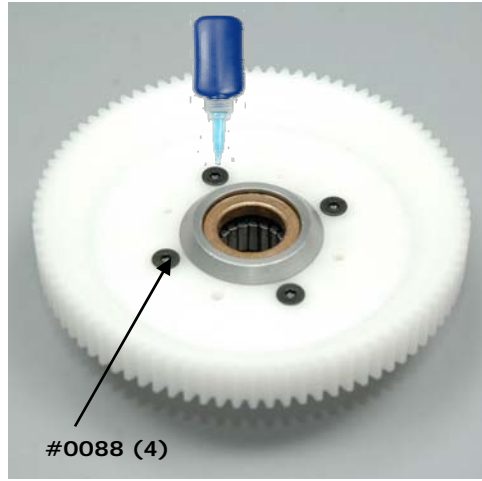

2D.1.c

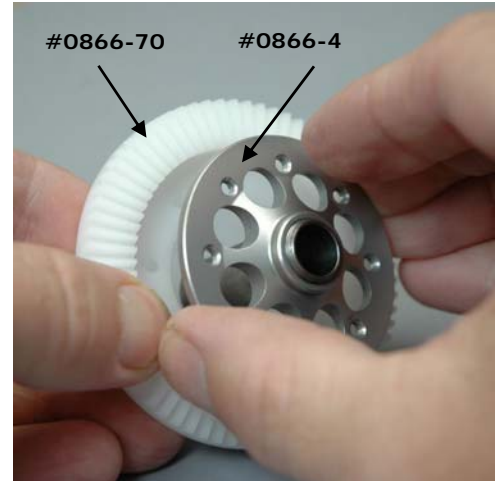

2D.1.d



2D.1.e

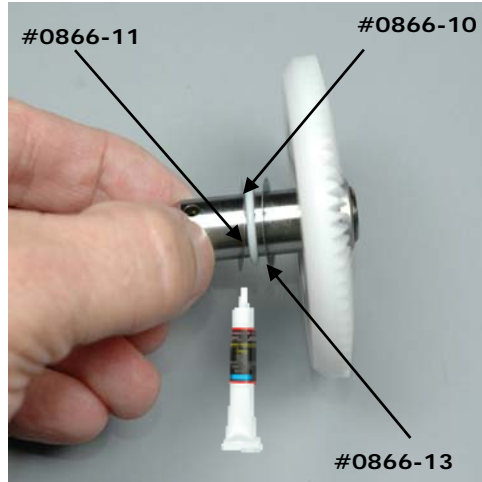

2D.1.f

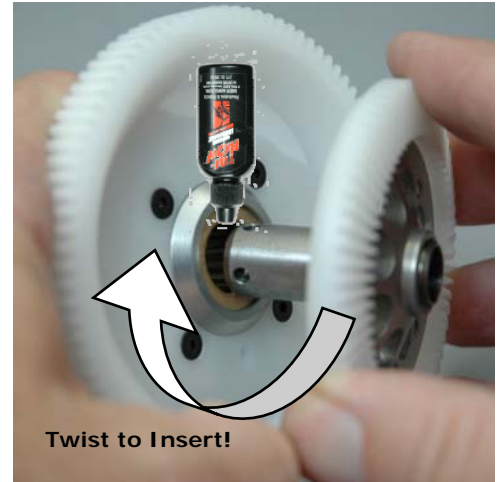

2D.1.g



2D.1.h



2D.1.i



2D.2 – Install Main Shaft/Collars

Parts Relationship

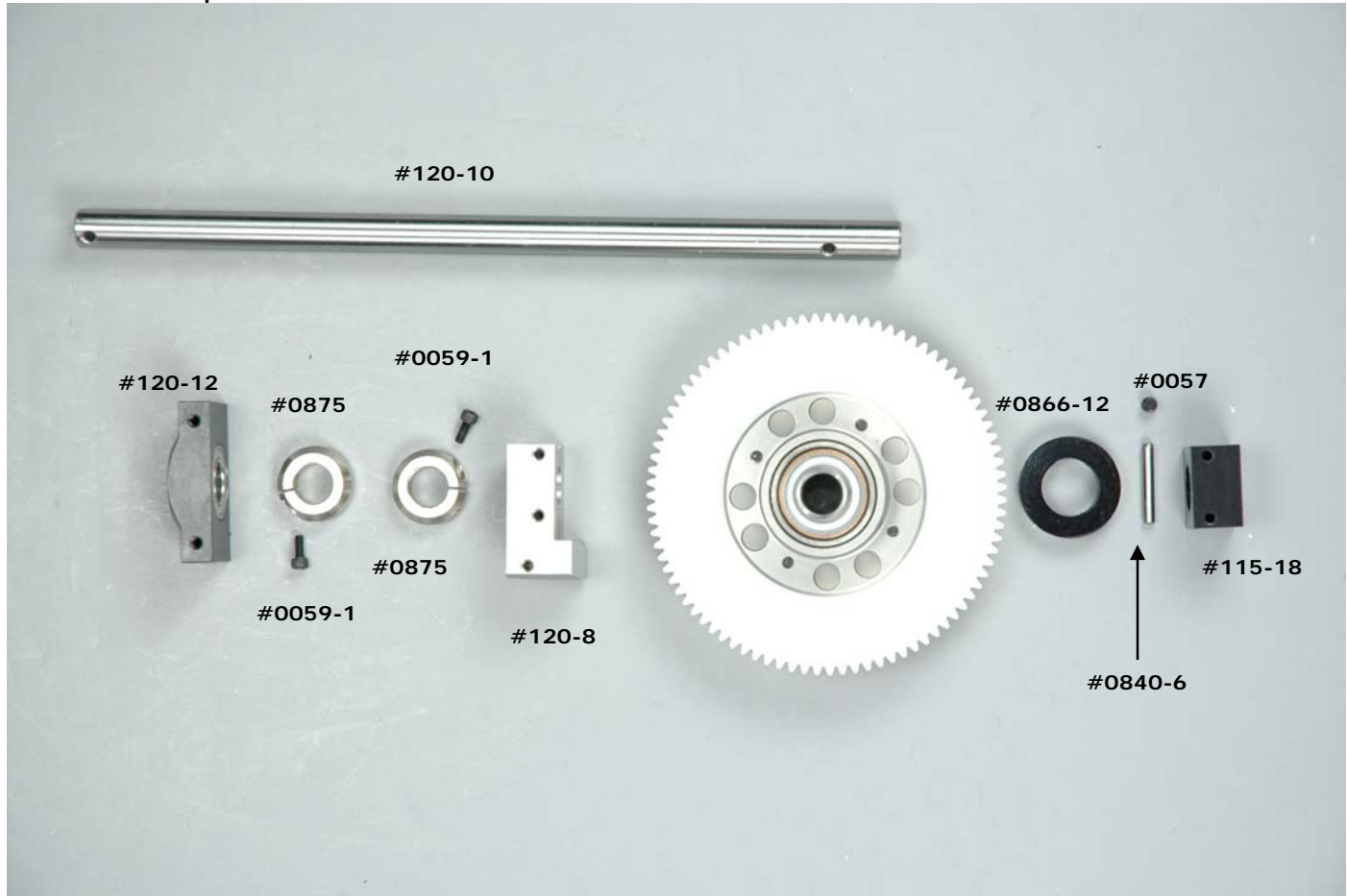

2D.2.a



2D.2.b



Building Notes – note the positions of the bevels on the shaft collars.

Note the orientation of the mainshaft. The holes on each end of the shaft are different.

2D.3 – Install Constant Drive

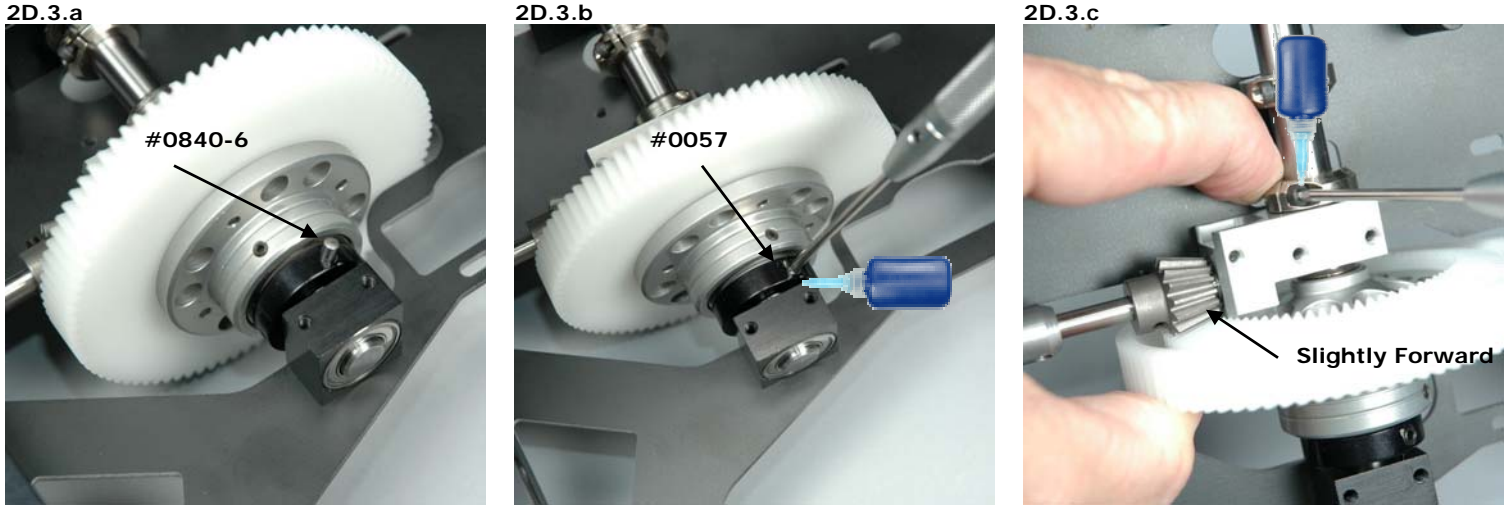

Building Notes – Do not over tighten the set screw that captures the retaining pin

Before tightening the lower main shaft collar, move the t/r pinion gear forward by 1/8". Using two fingers hold pressure between the lower collar and the constant drive. Now tighten the lower retaining collar

Do not over tighten the bolts in the collars! Tighten until the bolt seats on the collar and then tighten an additional ¼ turn.

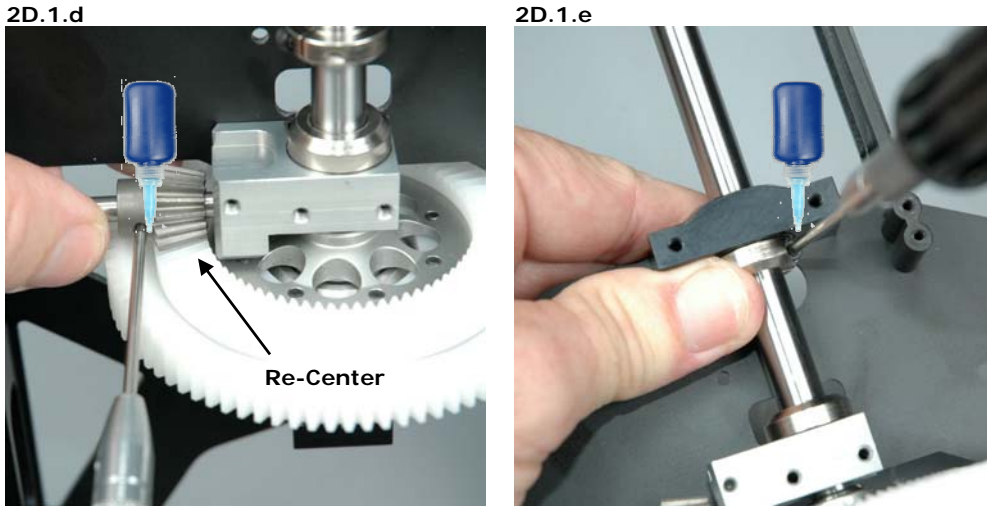

Building Notes – reposition the t/r pinion gear so that it's centered on the crown gear.

Tighten the two set screws in the pinion gear. Make sure the one on the shaft flat is centered on the flat

Do not over-tighten as this may distort the gear.

2D.4 – Install Left Gear Ratio Plate

2D.4.a

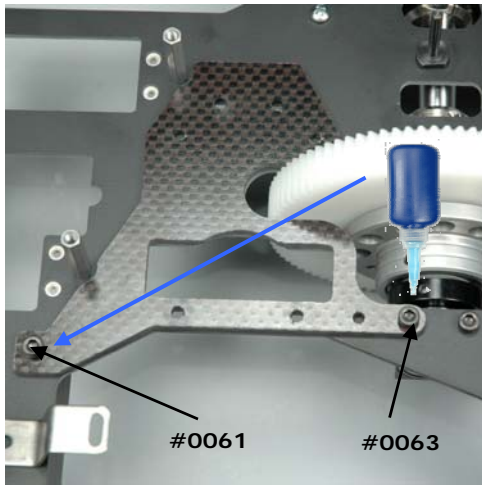

Building Notes – the ratio plates are marked as left and right versions. Make sure you install the correct plate on the correct side.

E) Clutch Assembly - Bag #2E



Parts Relationship



2E.1 - Assemble Clutch

2E.1.a

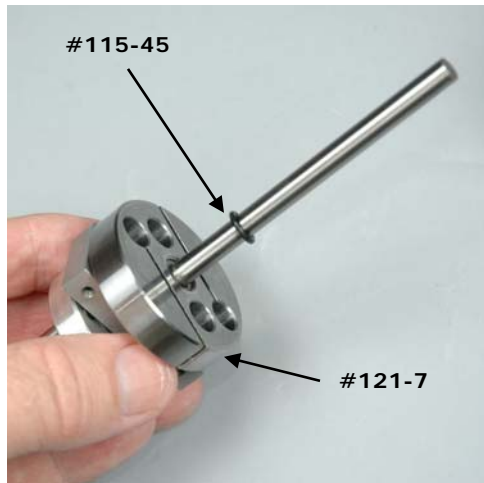

2E.1.b



Building Notes – Do not lubricate the o-ring

2E.2 - Install Clutch Assembly

2E.2.a

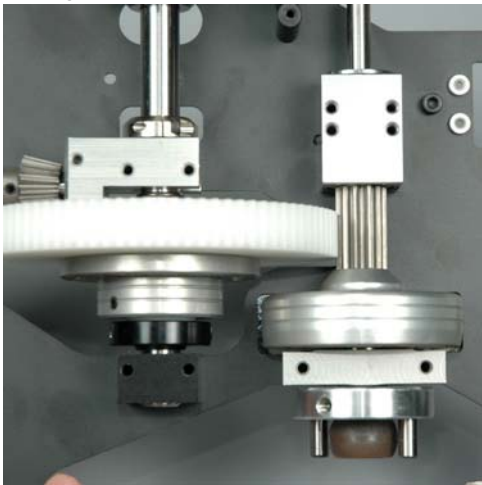

2E.2.b

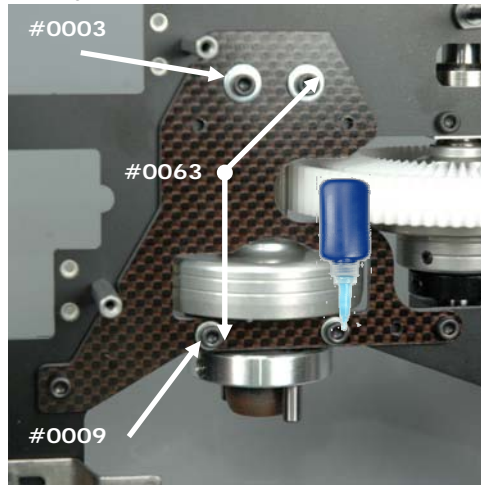

2E.2.c

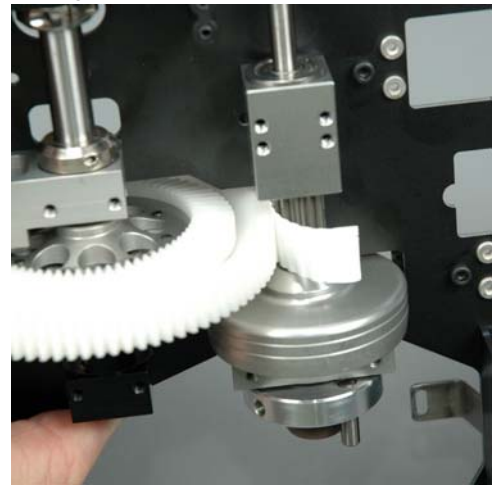

Building Notes – Do not tighten the four clutch bolts until gear spacing has been set.

Set the gear spacing by running a small strip of paper between the gears as shown. While the paper strip is between the gears, tighten the four clutch bolts. Don't forget to use thread lock.

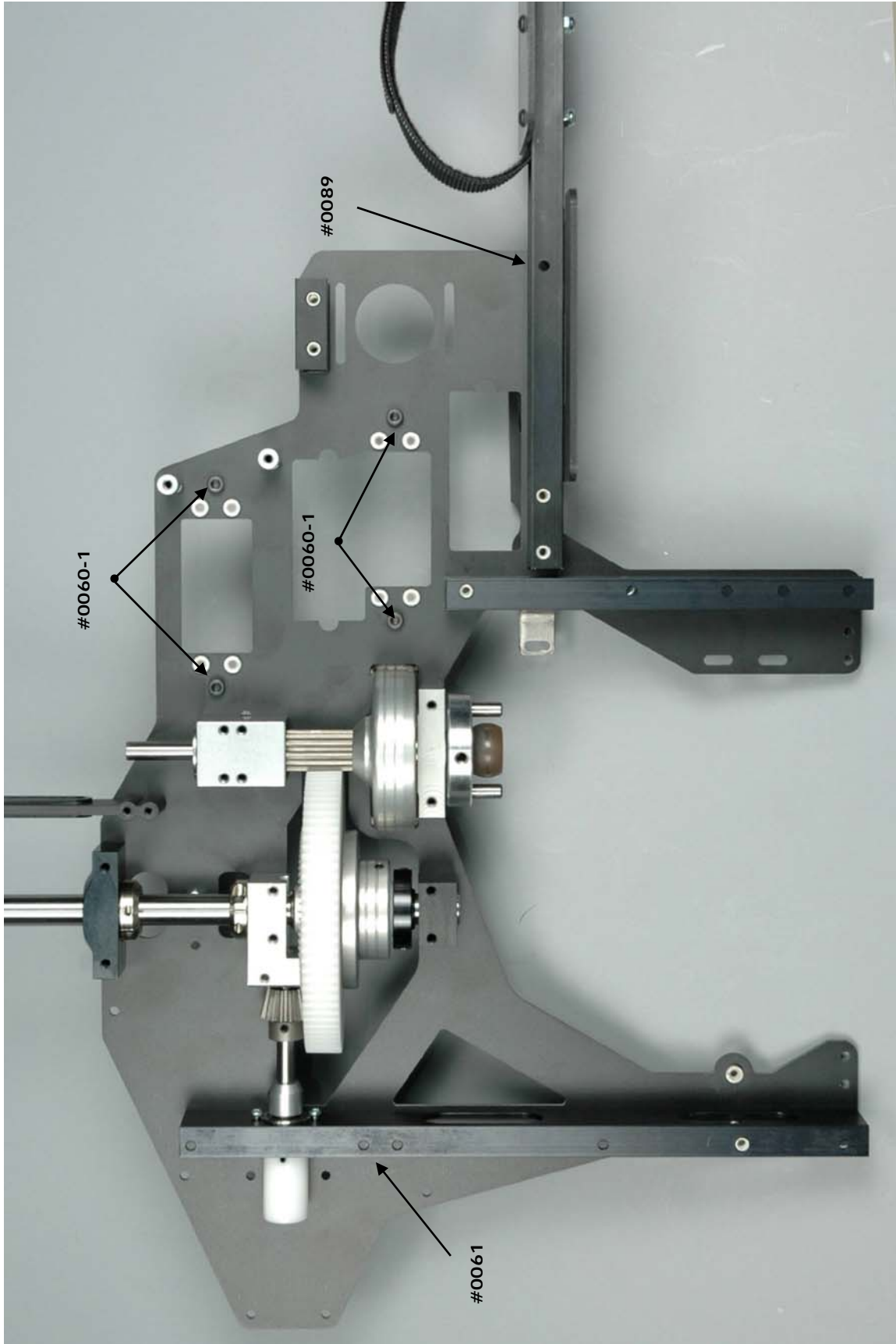

XCell Fury Extreme Assembly Manual

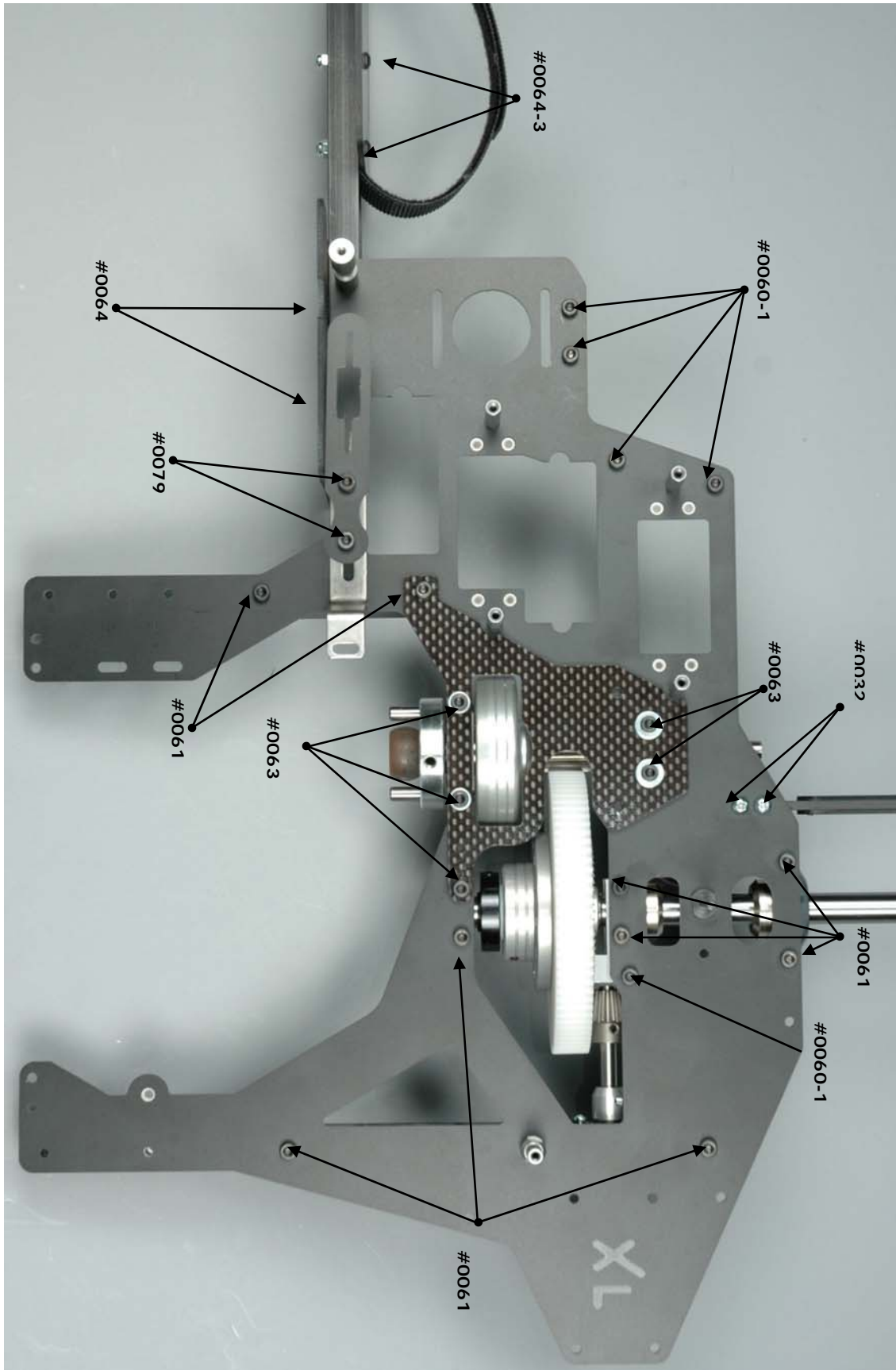

Step #3 – Right Frame

A) Right Frame - Bag #3A

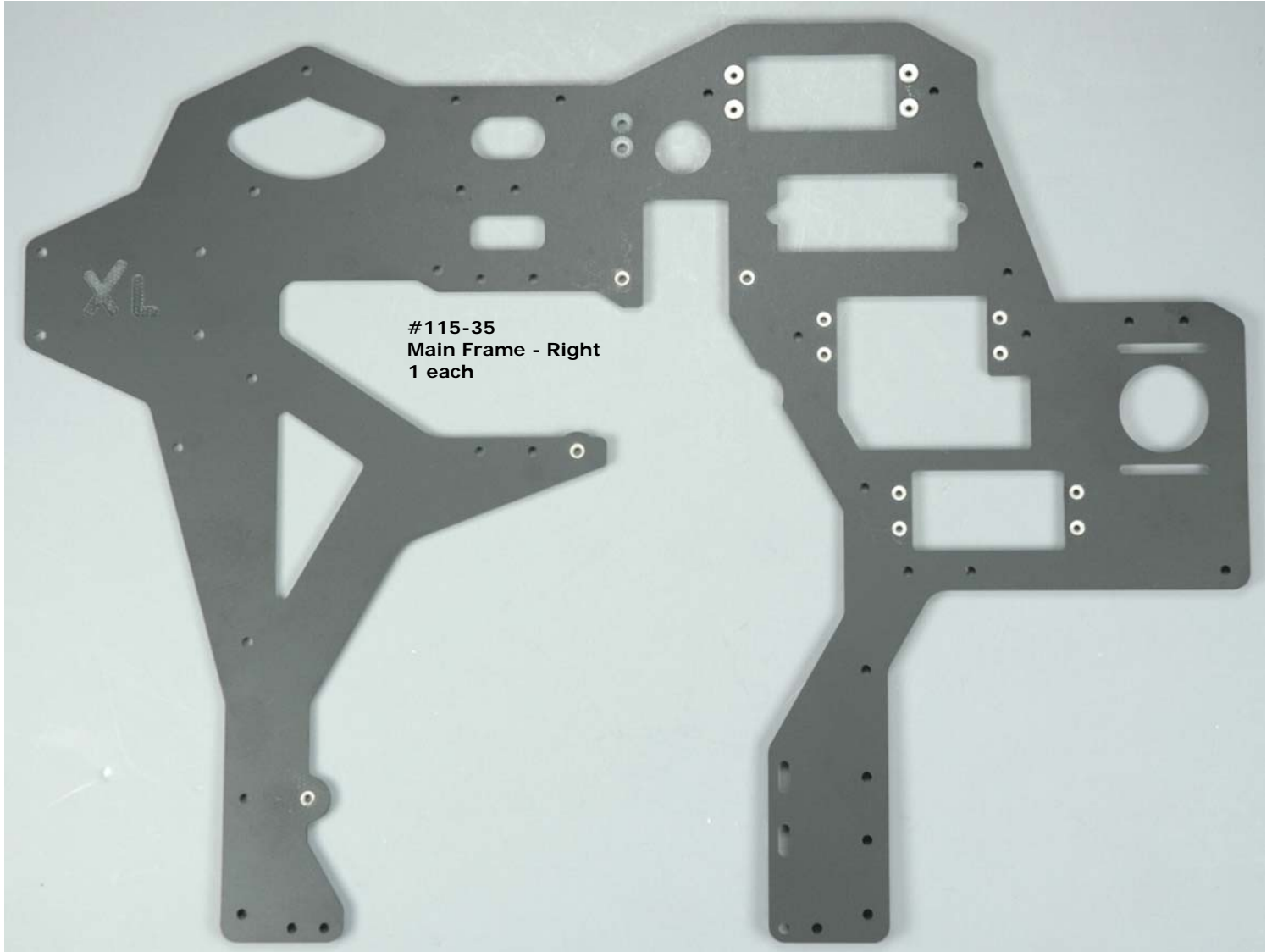

B) Right Frame Components - Bag #3B

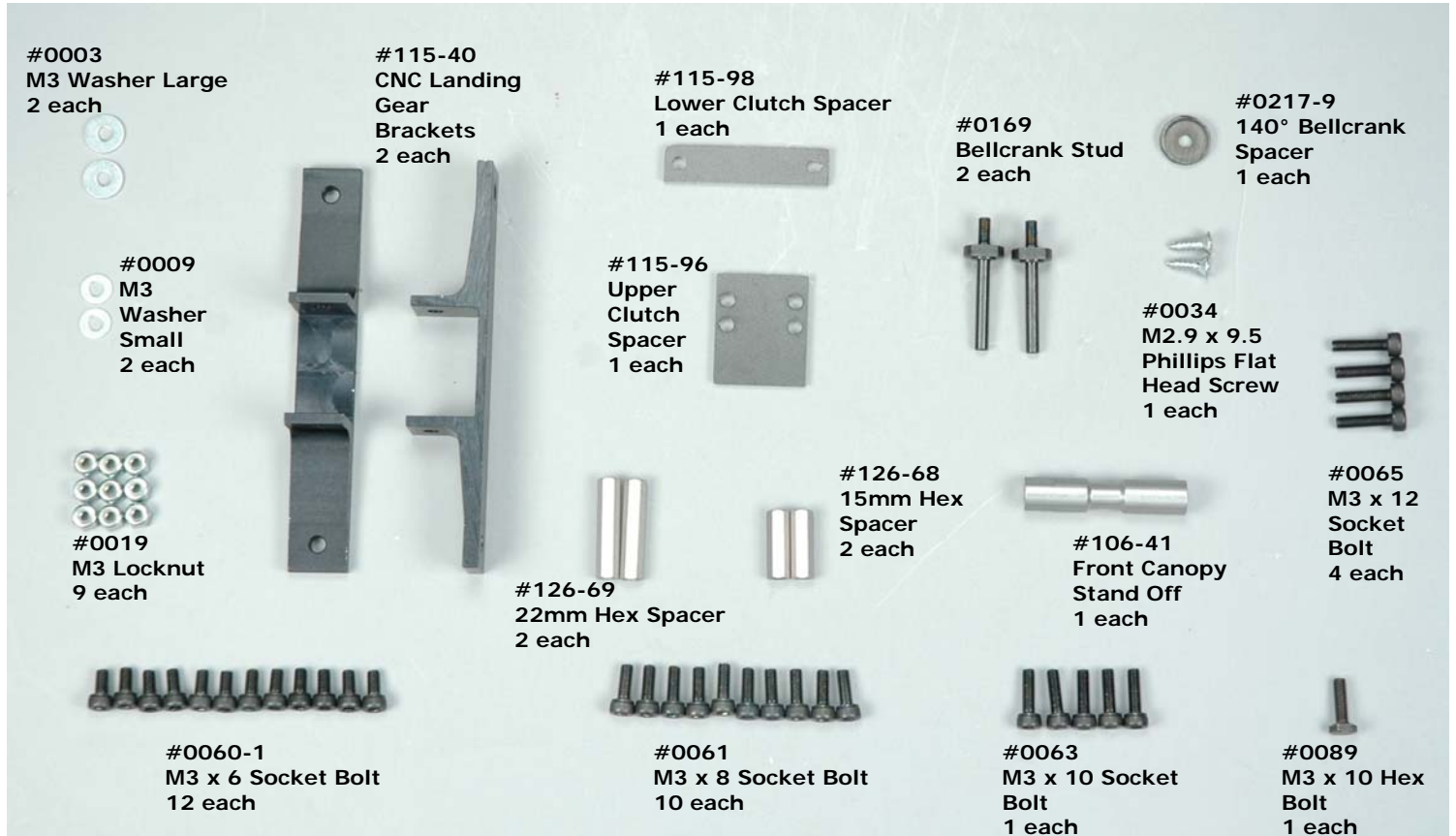

XCell Fury Extreme Assembly Manual

3B.1 – Assemble Right Frame

Parts Relationship

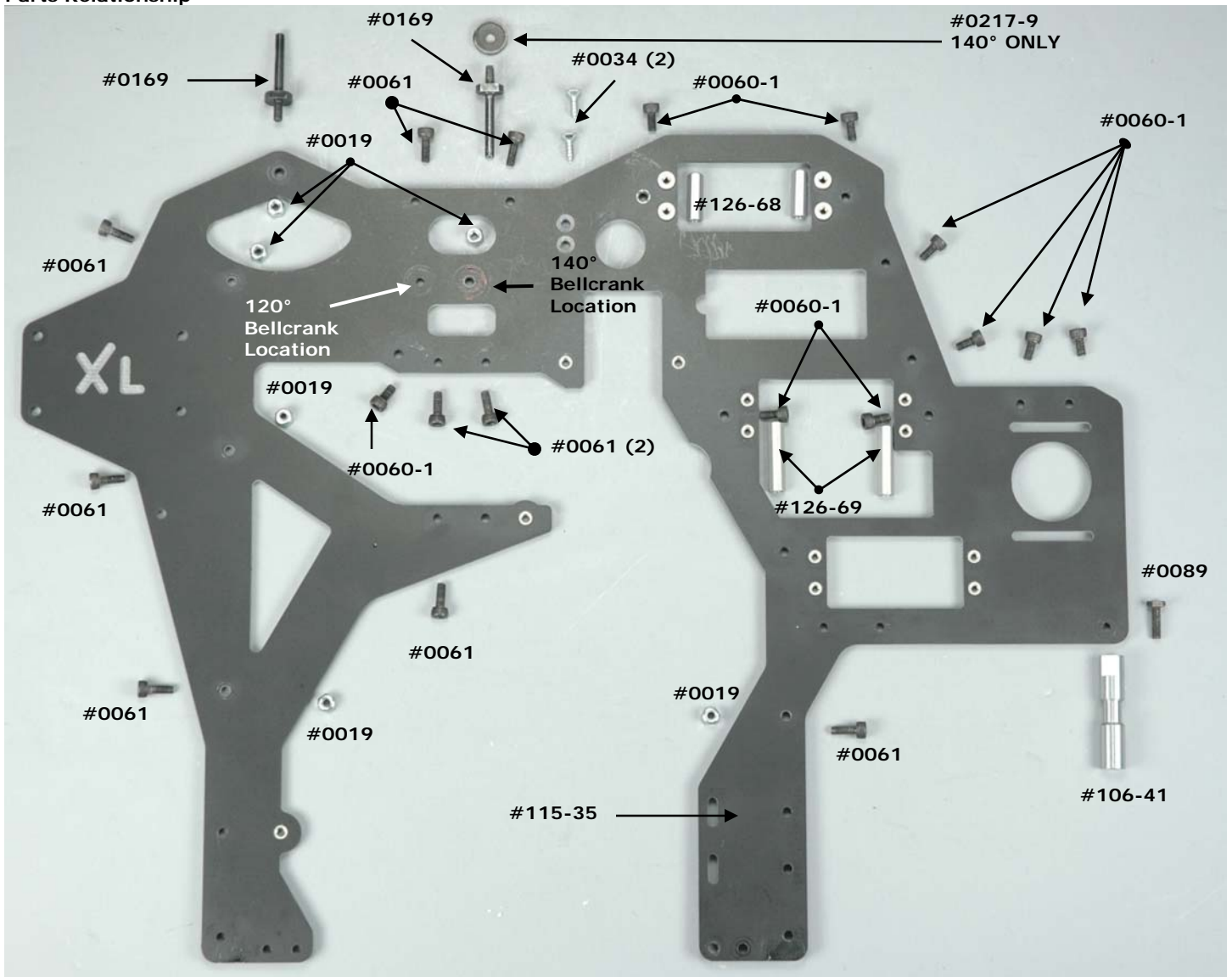

XCell Fury Extreme Assembly Manual

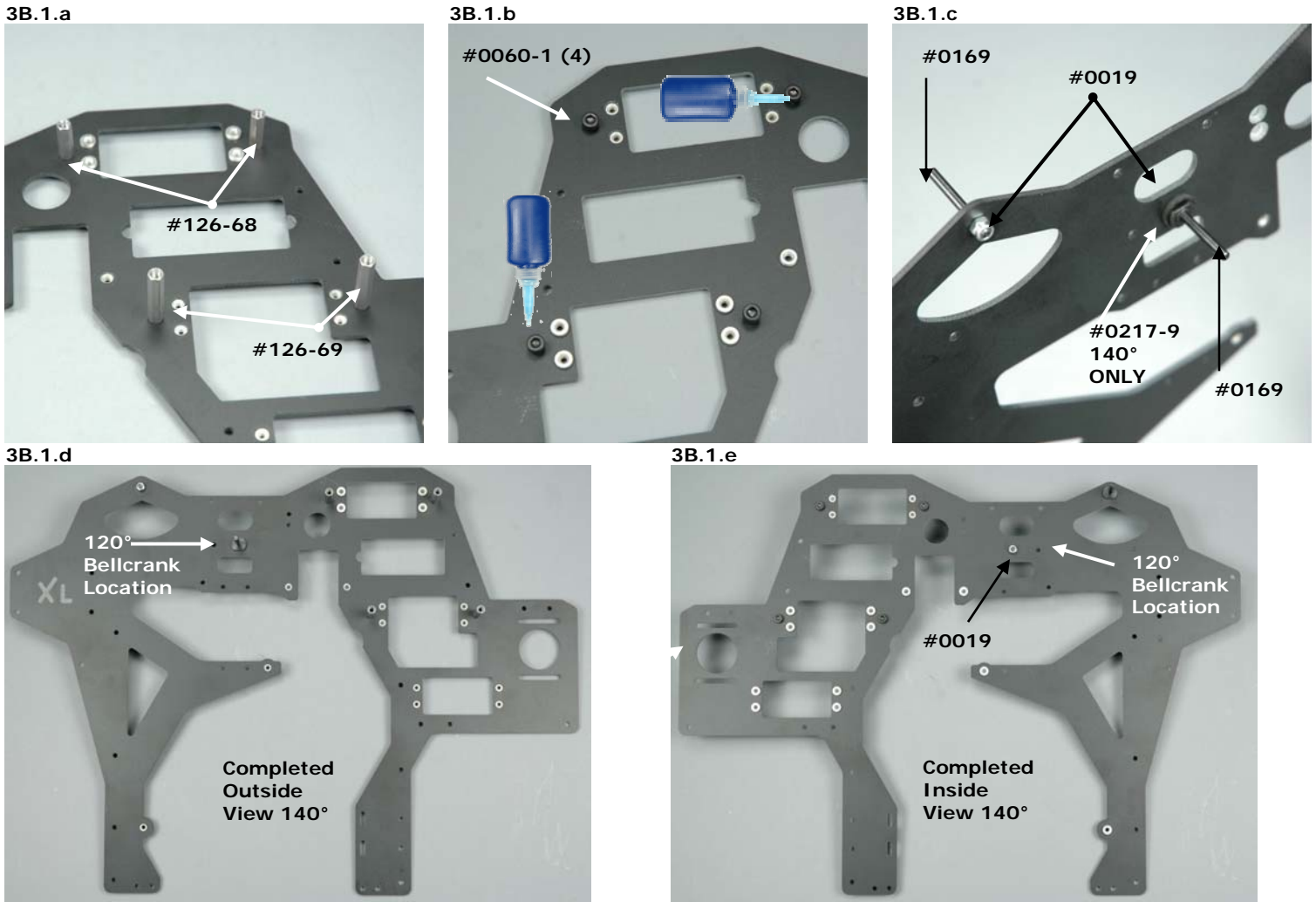

3B.2 – Install Right Frame

3B.2.a

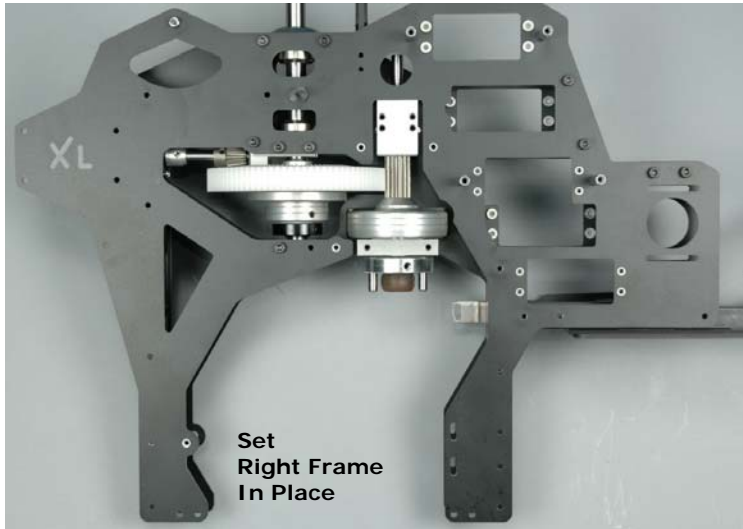

3B.2.b

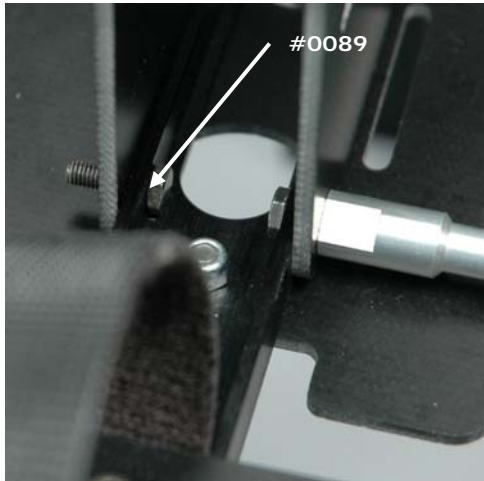

3B.2.c

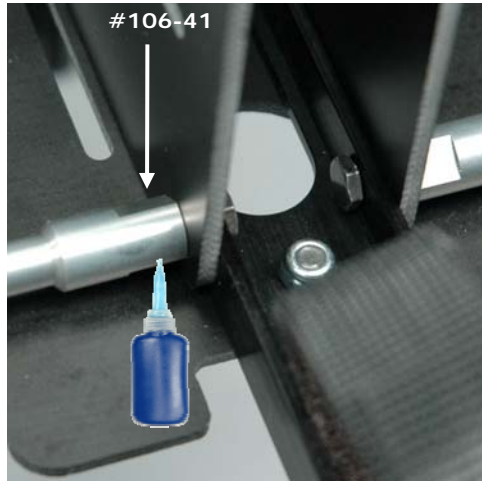

3B.2.d

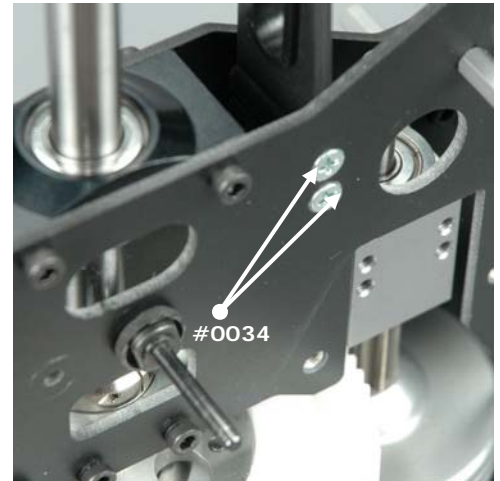

3B.2.e

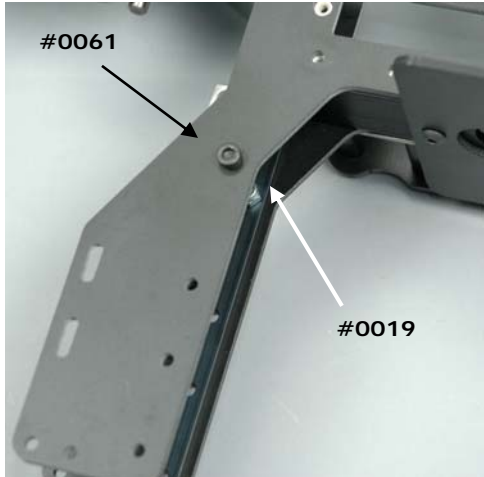

3B.2.f

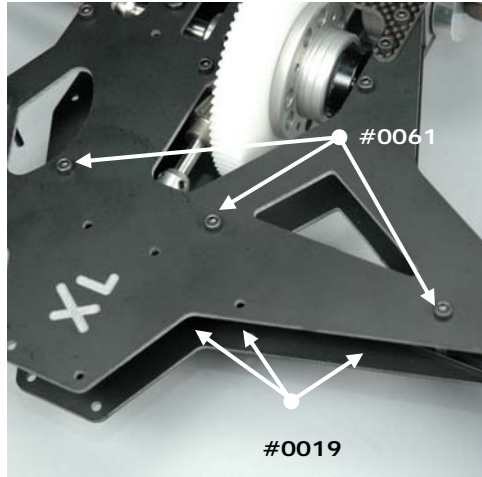

Building Notes – Install the bolts through the frame channels with lock nuts.

Make sure any threaded bolts that don't use lock nuts are installed with thread lock.

XCell Fury Extreme Assembly Manual

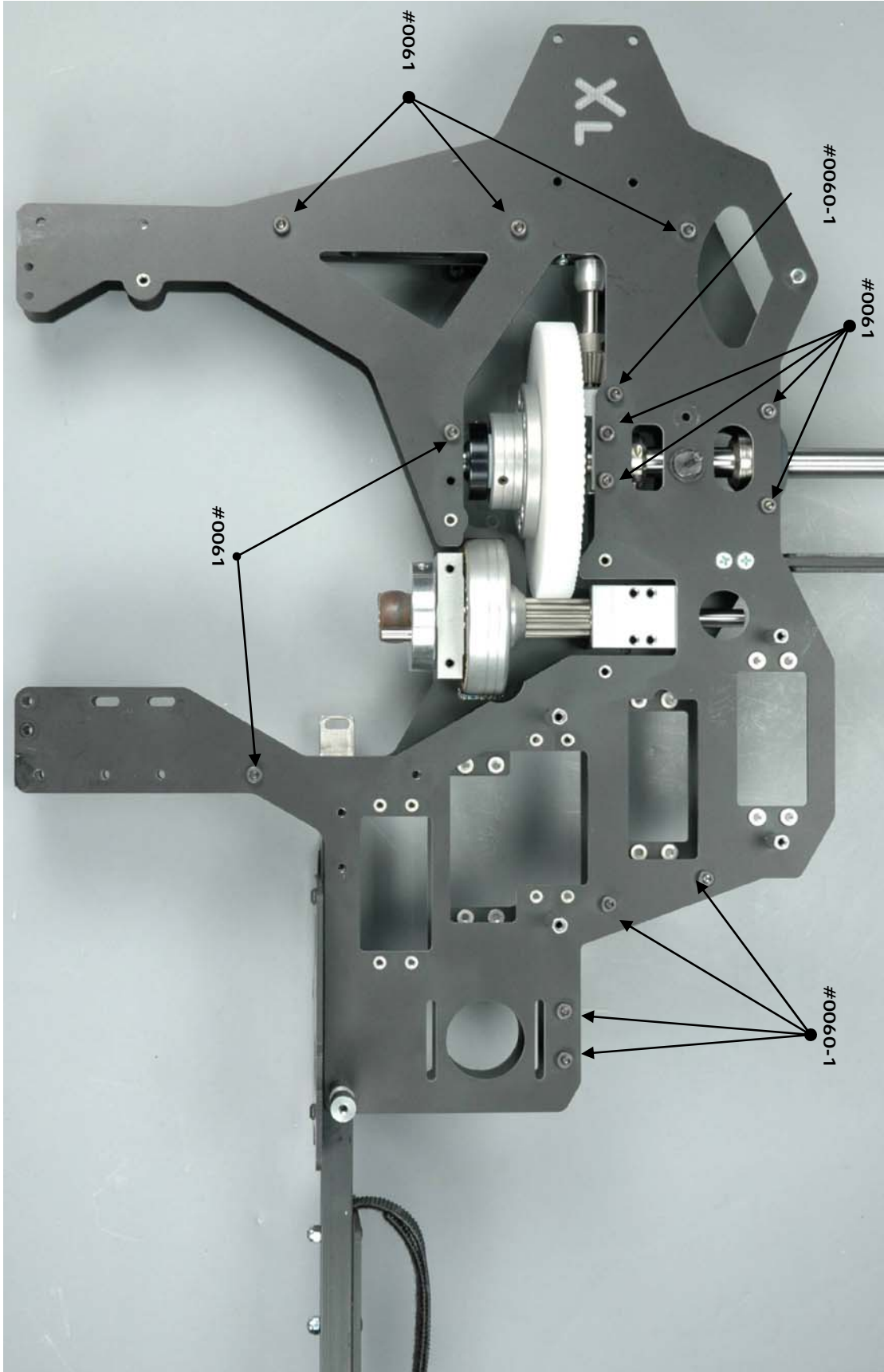

3B.3 - Install Right Ratio Plate

Parts Relationship

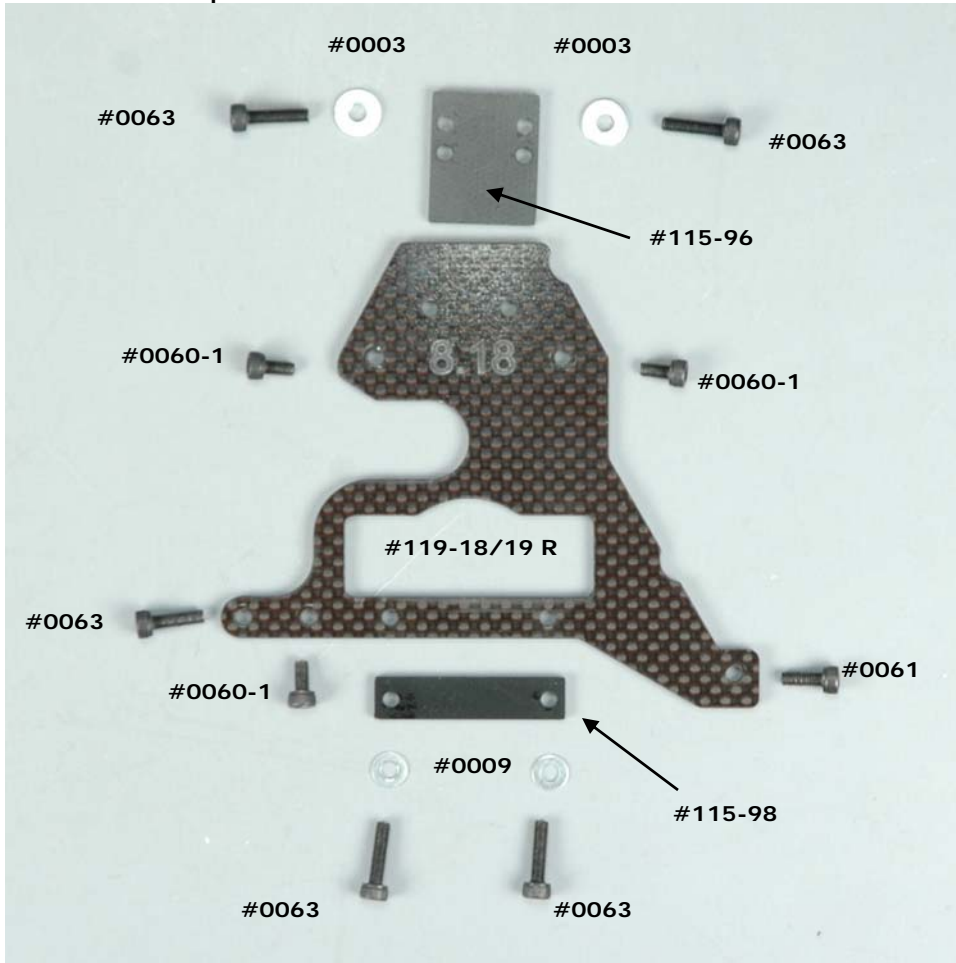

3B.3.a

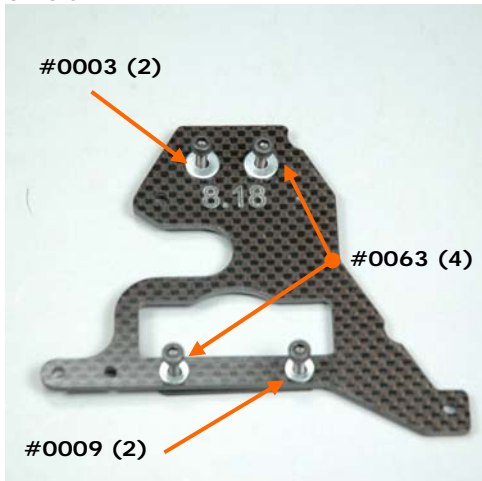

3B.3.b

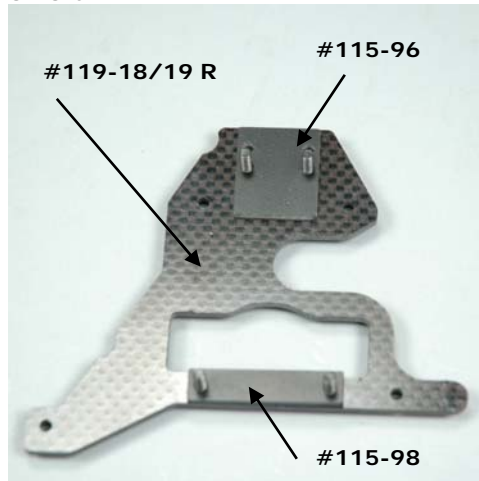

3B.3.c

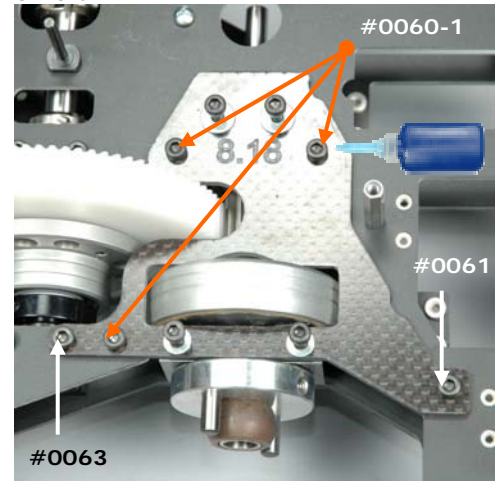

XCell Fury Extreme Assembly Manual

3B.3.d



Building Notes – After the ratio plate is in place, first tighten the bolts around the outside of the plate.

Then tighten the four bolts that attach the plate to the clutch assembly.

Make sure all bolts are installed with thread lock.

3B.4 – Install Landing Gear Mounts

Parts Relationship

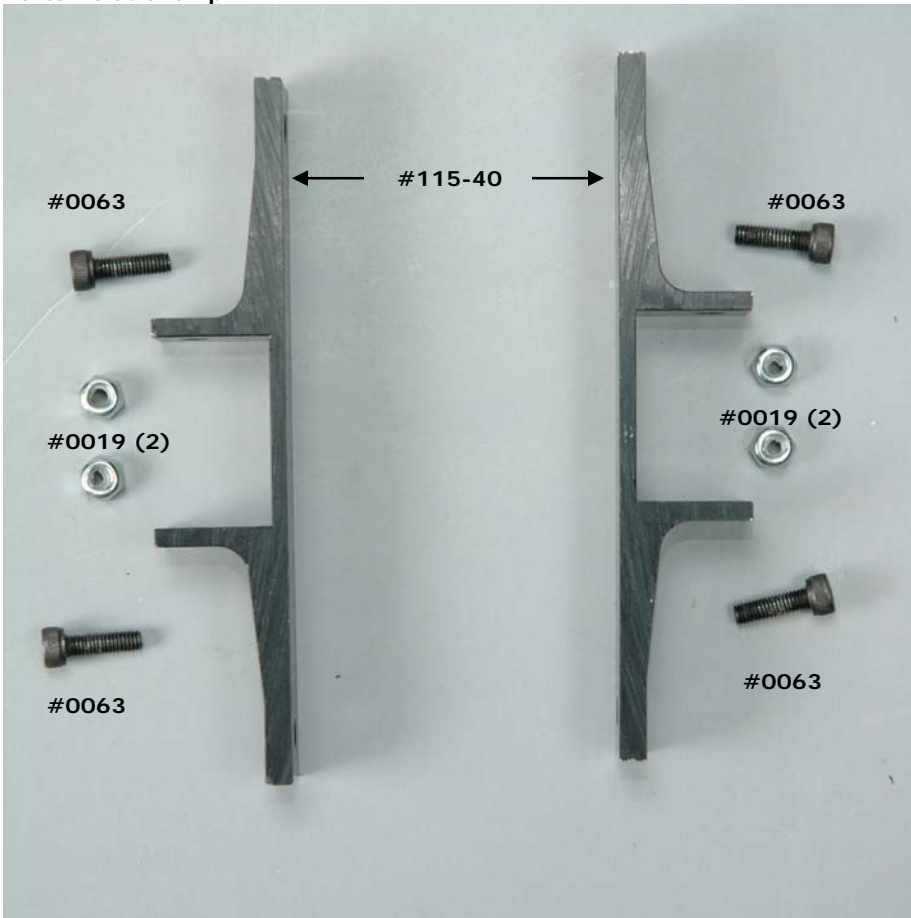

C) Control Bellcranks - Bag #3C

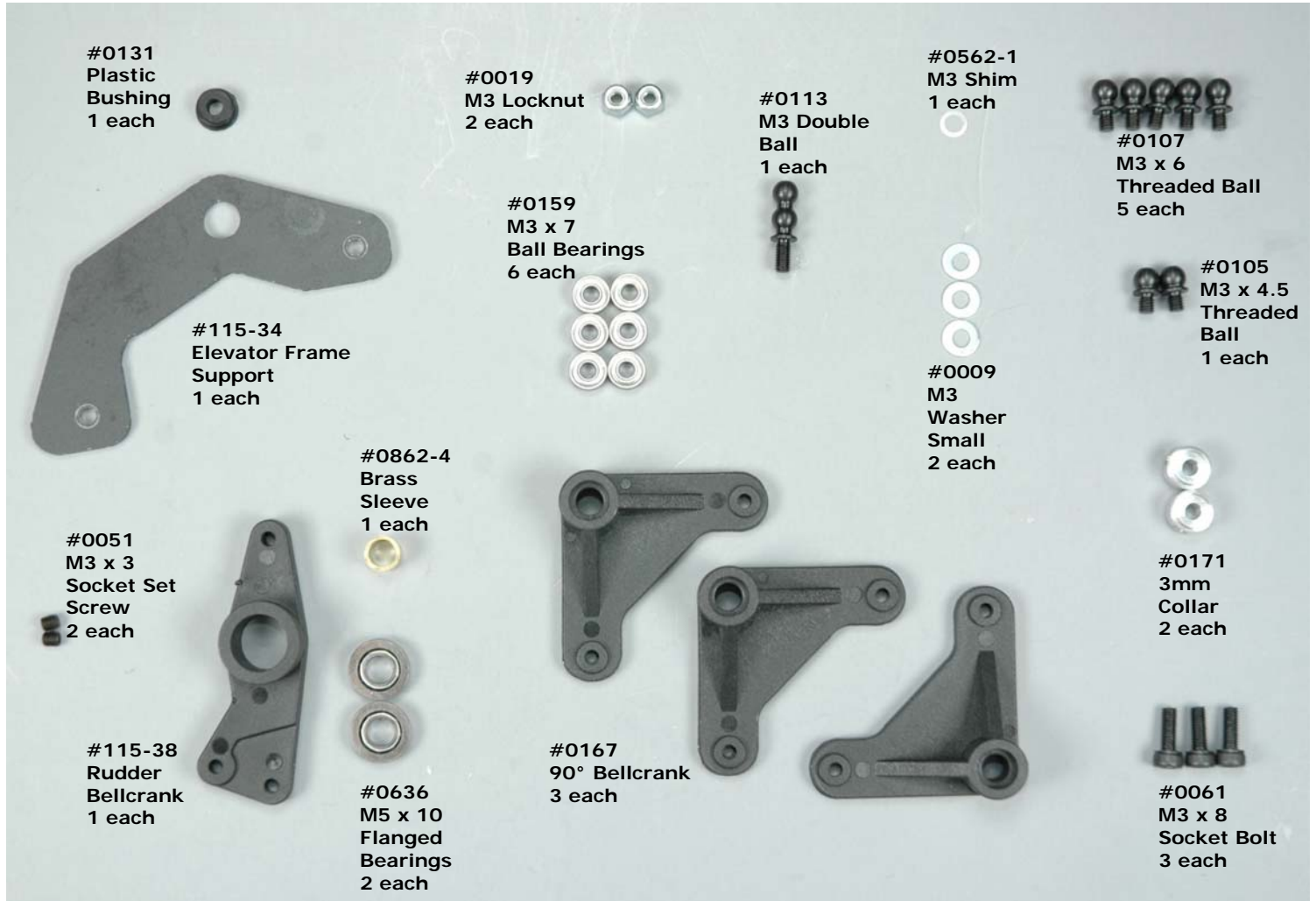

3C.1 – Assemble Aileron/Pitch Bellcranks

Parts Relationship



3C.1.a

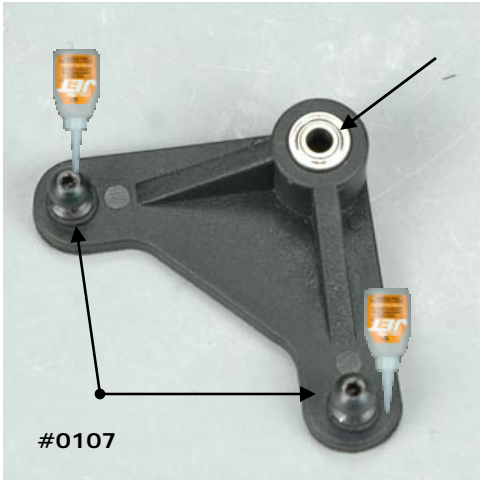

3C.1.b



3C.2 – Install Aileron/Pitch Bellcranks

3C.2.a



3C.2.b



3C.3 - Assemble Elevator Bellcrank

Parts Relationship

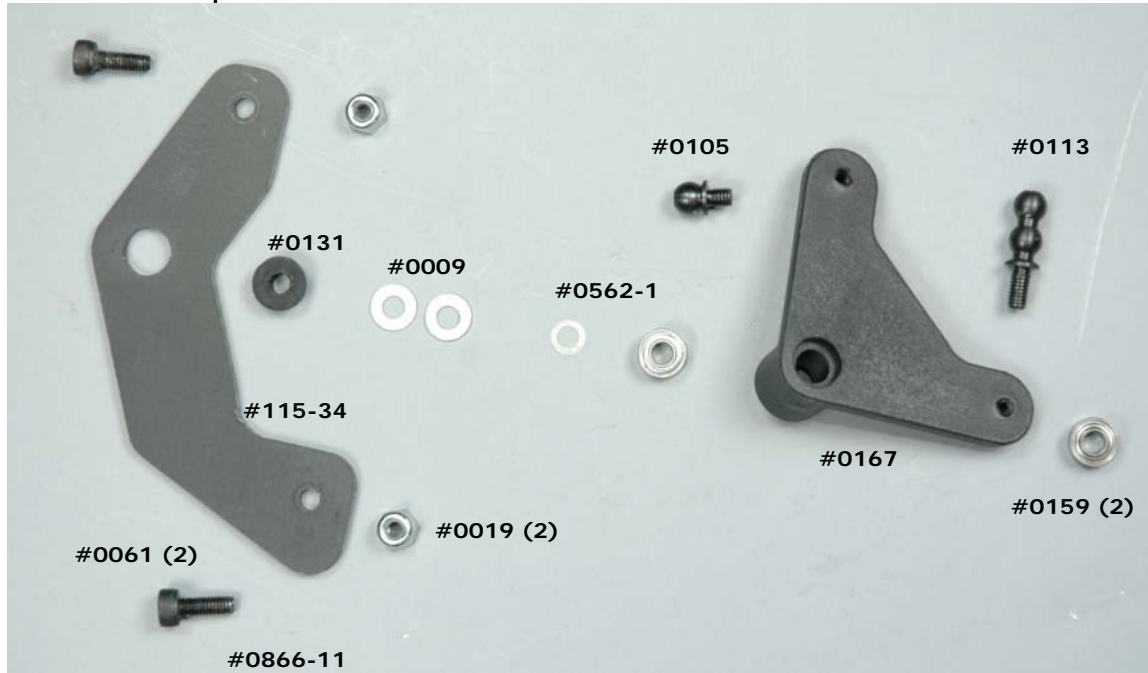

3C.3.a



3C.3.b

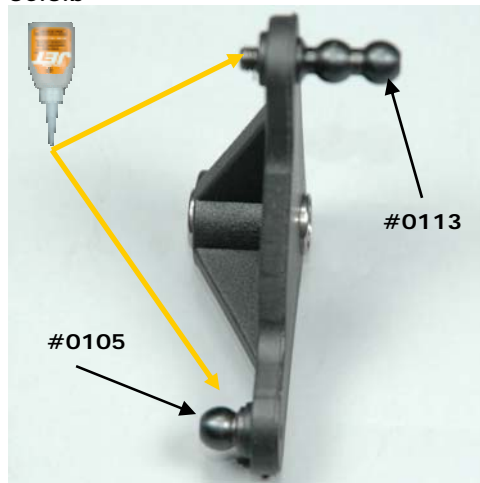

3C.4 - Install Elevator Bellcrank

3C.4.a



3C.4.b

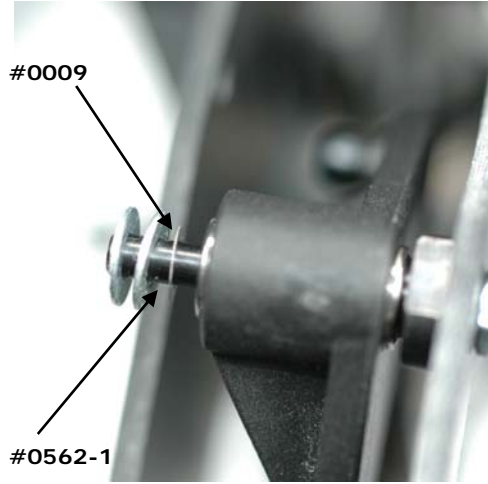

3C.4.c

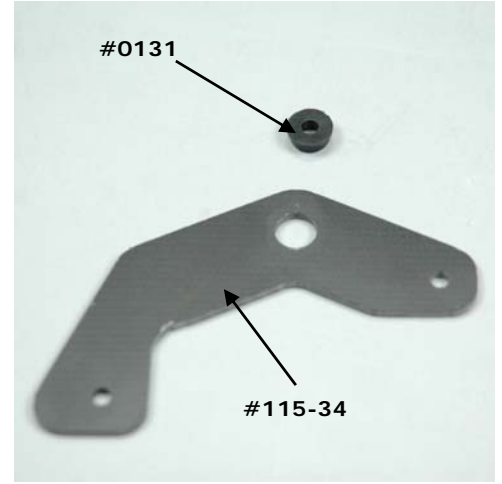

3C.4.d



3C.4.e

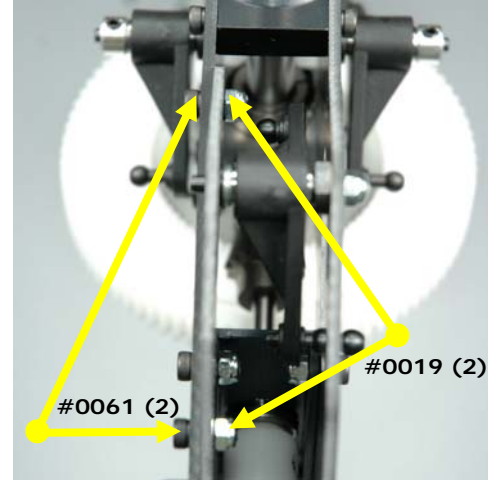

3C.4.f



XCell Fury Extreme Assembly Manual

3C.5 - Assemble Rudder Bellcrank

Parts Relationship

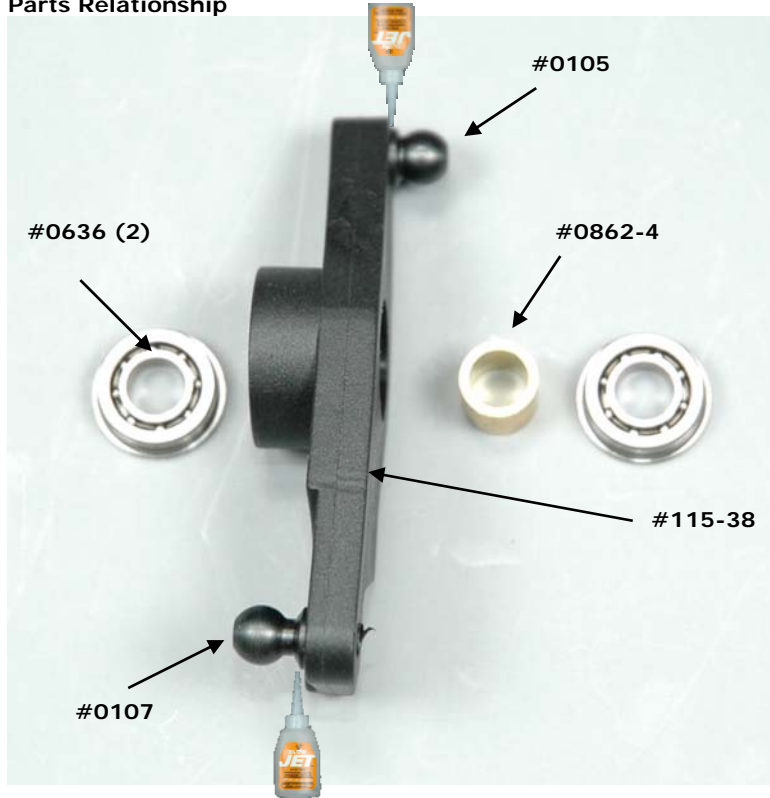

3C.5.a



3C.5.b



3C.5.c



3C.6 - Install Rudder Bellcrank

3C.6.a

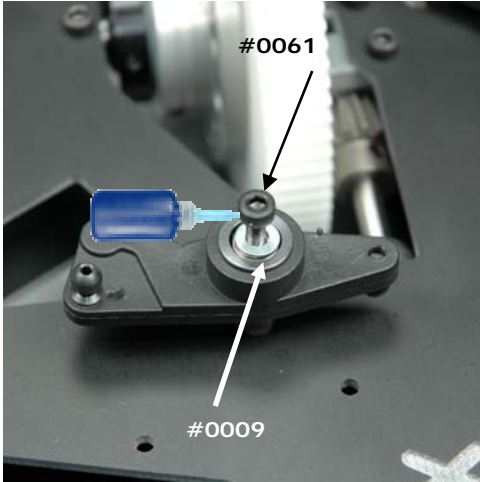

Step #4 – Frame Assembly

A) Chassis Components - Bag #4A

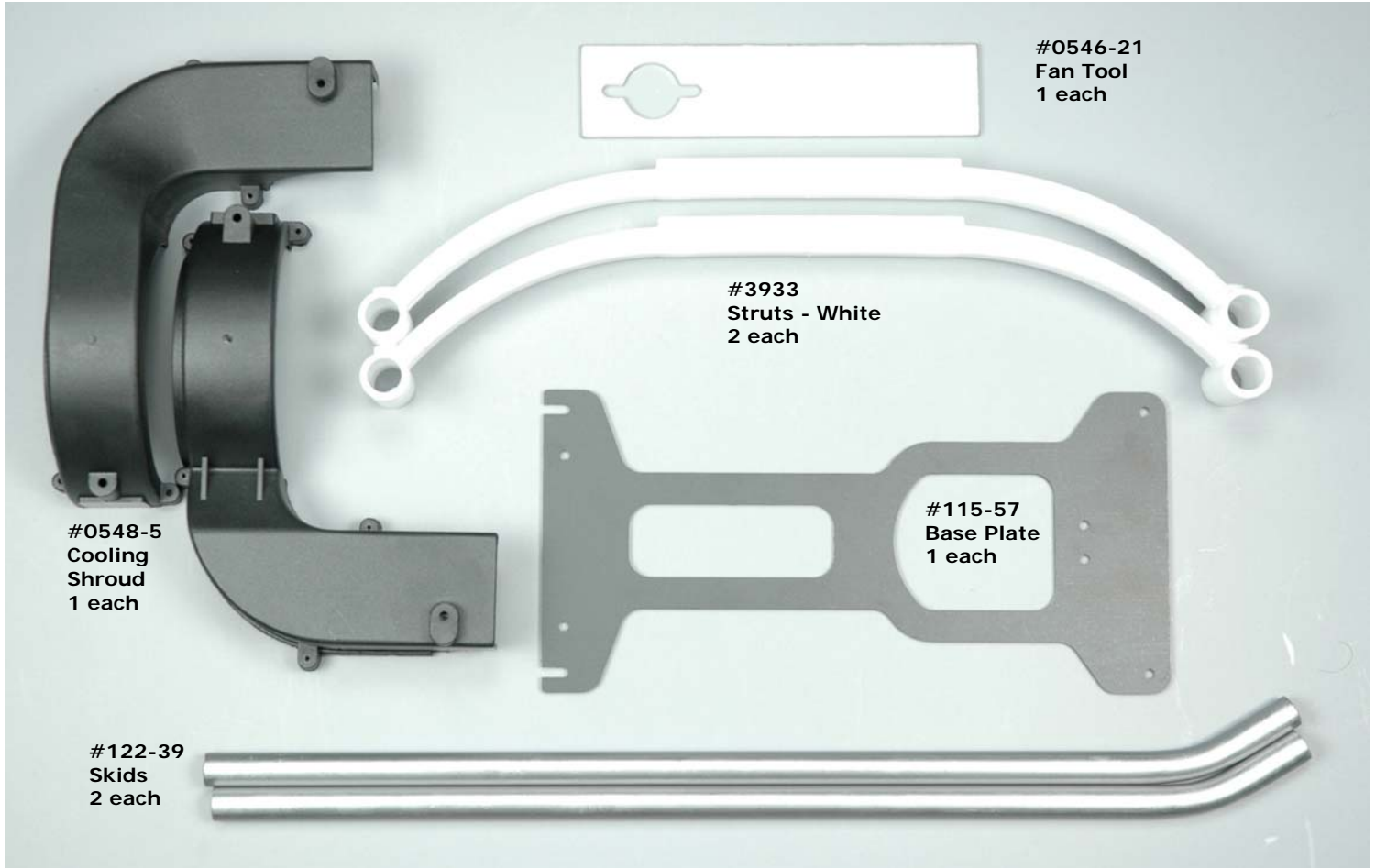

Building Notes – Locate Bag 4A which contains the lower frame components

These parts will be used in the following steps.

B) Engine Components - Bag #4B

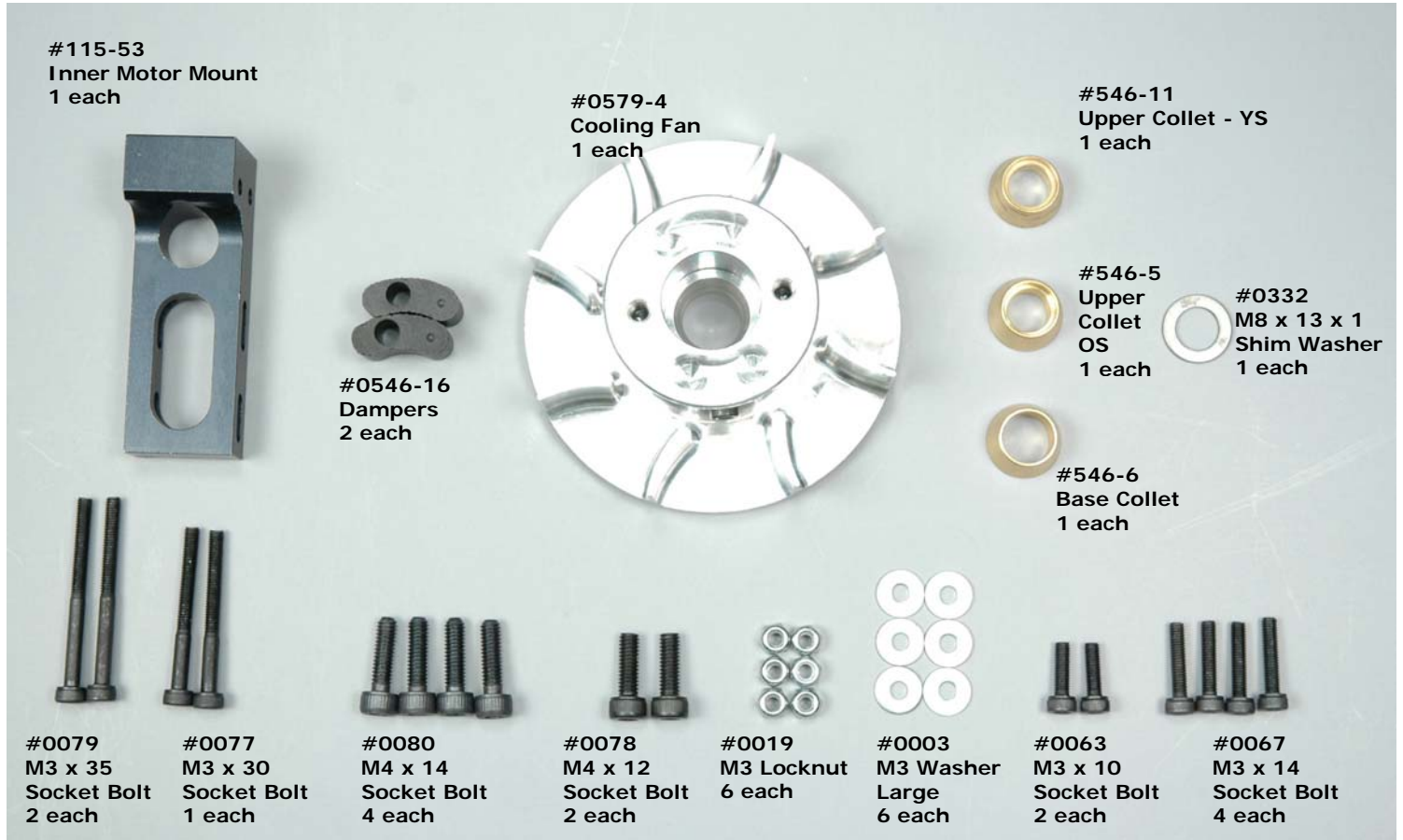

4B.1 – Prepare Engine

Parts Relationship

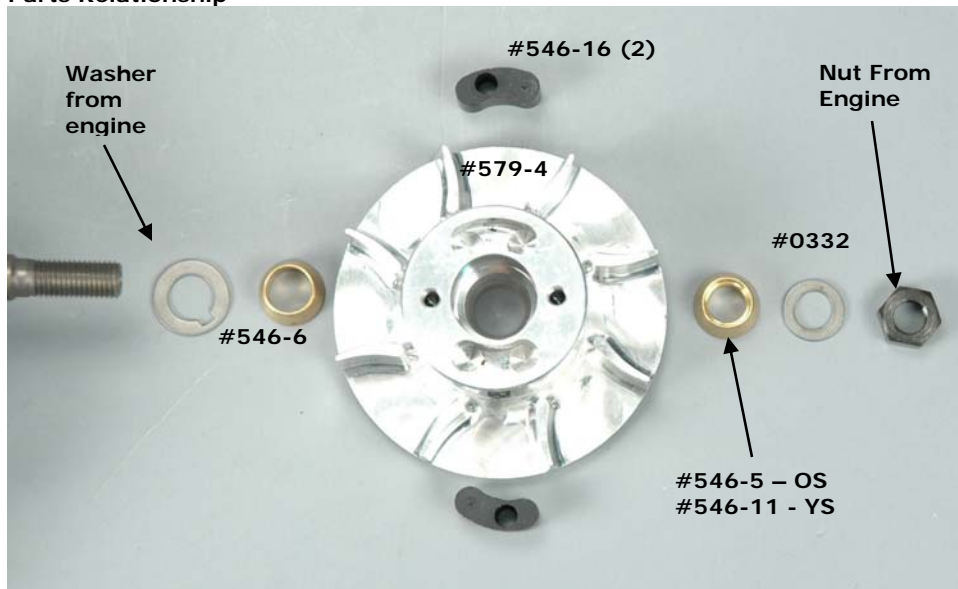

4B.1.a



4B.1.b



4B.1.c

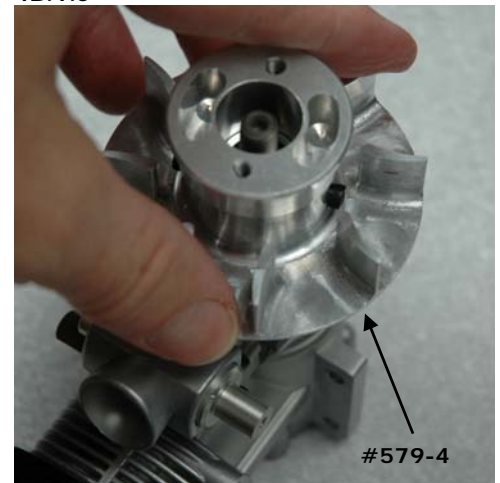

XCell Fury Extreme Assembly Manual

4B.1.d

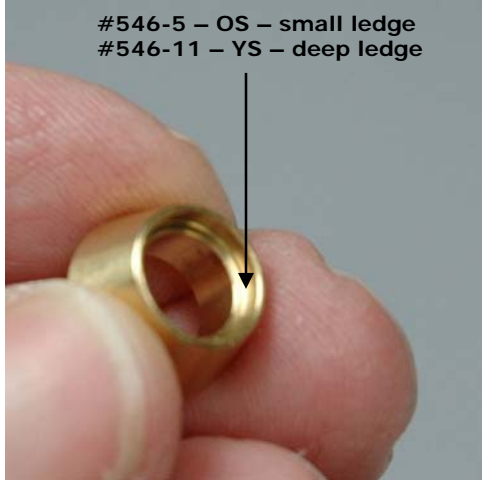

4B.1.e

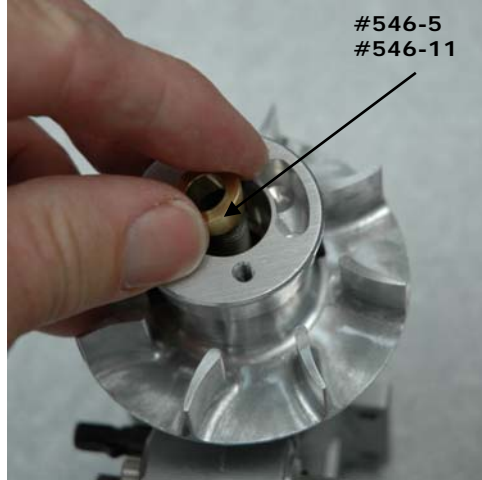

4B.1.f



4B.1.g

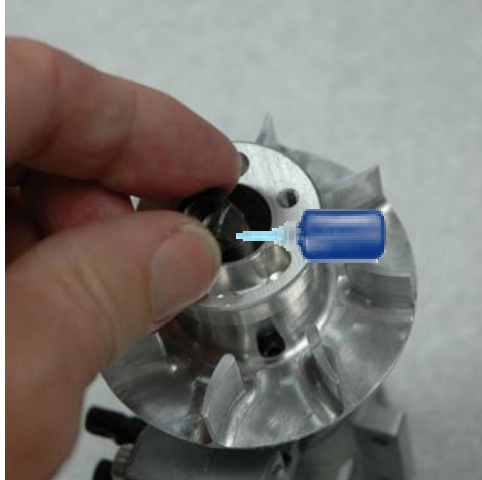

4B.1.h



4B.1.i

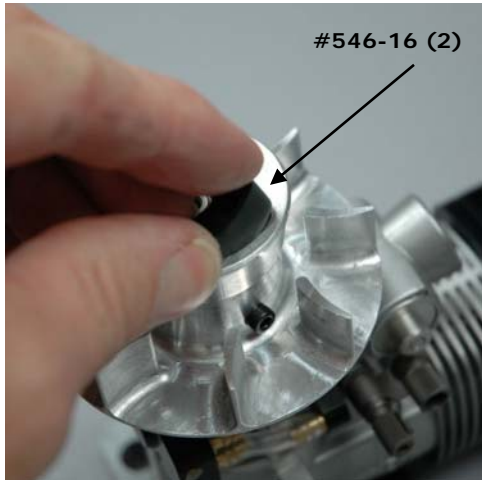

Building Notes – you should dial indicate the fan runout to less than .002" using a dial indicator as shown. Runout should be checked on both the face and the top edge of the fan hub.

The collet system usually makes alignment fairly easy, however if you're having problems getting runout to an acceptable level, contact Miniature Aircraft by phone or via the support forum located on the website.

4B.2 – Install Engine Mounts

Parts Relationship

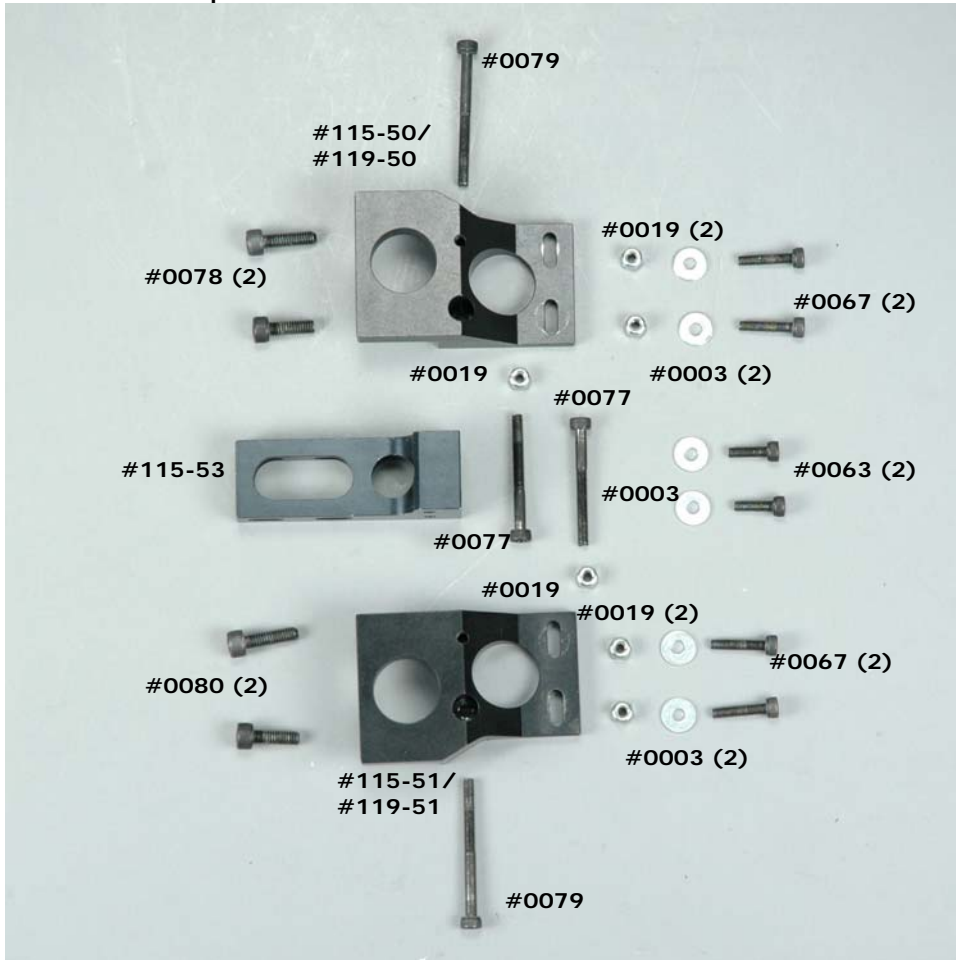

4B.2.a



4B.2.b

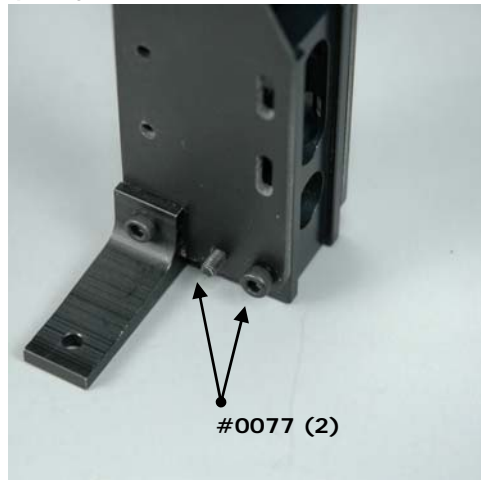

4B.2.c

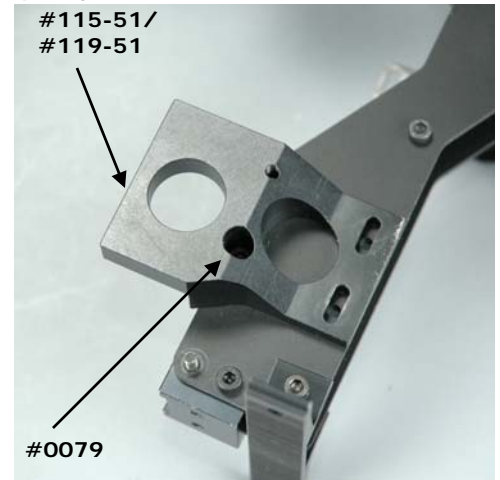

XCell Fury Extreme Assembly Manual

4B.2.d

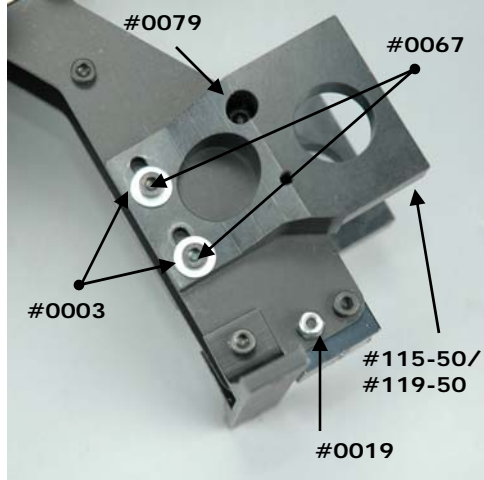

4B.2.e

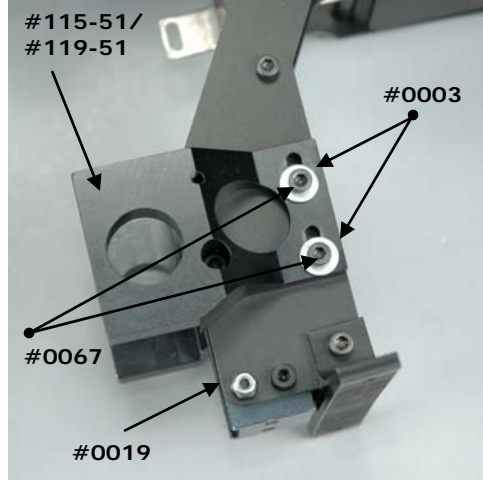

4B.2.f



4B.2.g



4B.3 – Install Engine

4B.3.a



4B.3.b

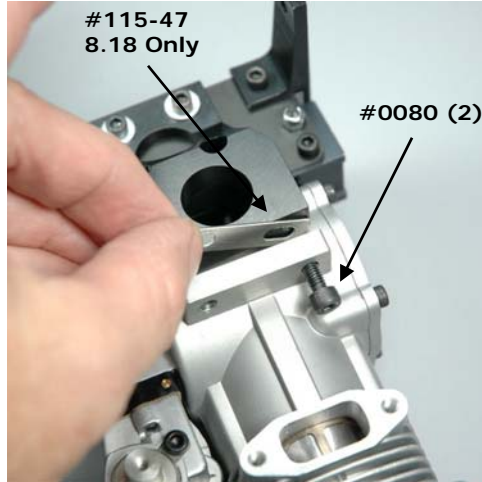

4B.3.c

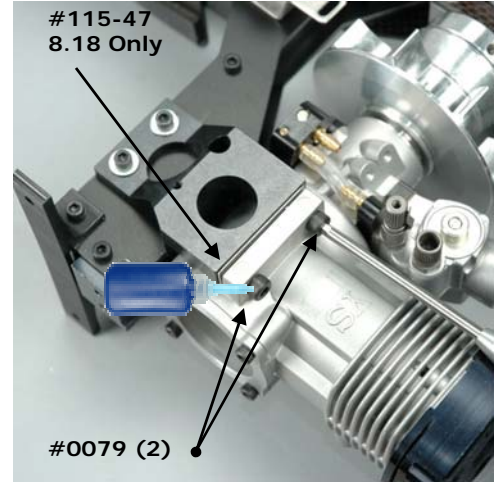

4B.3.d

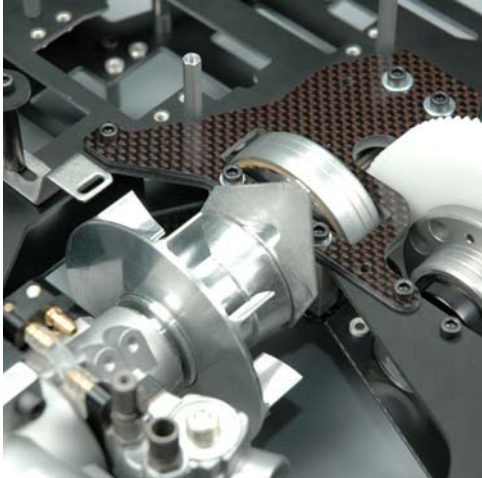

4B.3.e

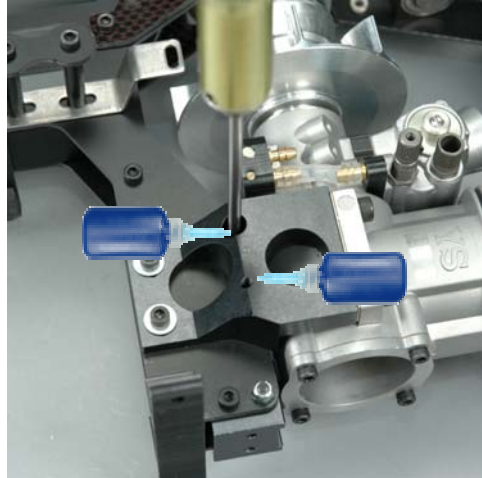

Building Notes – There should be no more than .020" gap between the fan and clutch driver. Use the clutch gap tool as shown or feeler gauges.

Push the motor against the guage before tightening the mount bolts.

C) Landing Gear - Bag #4C

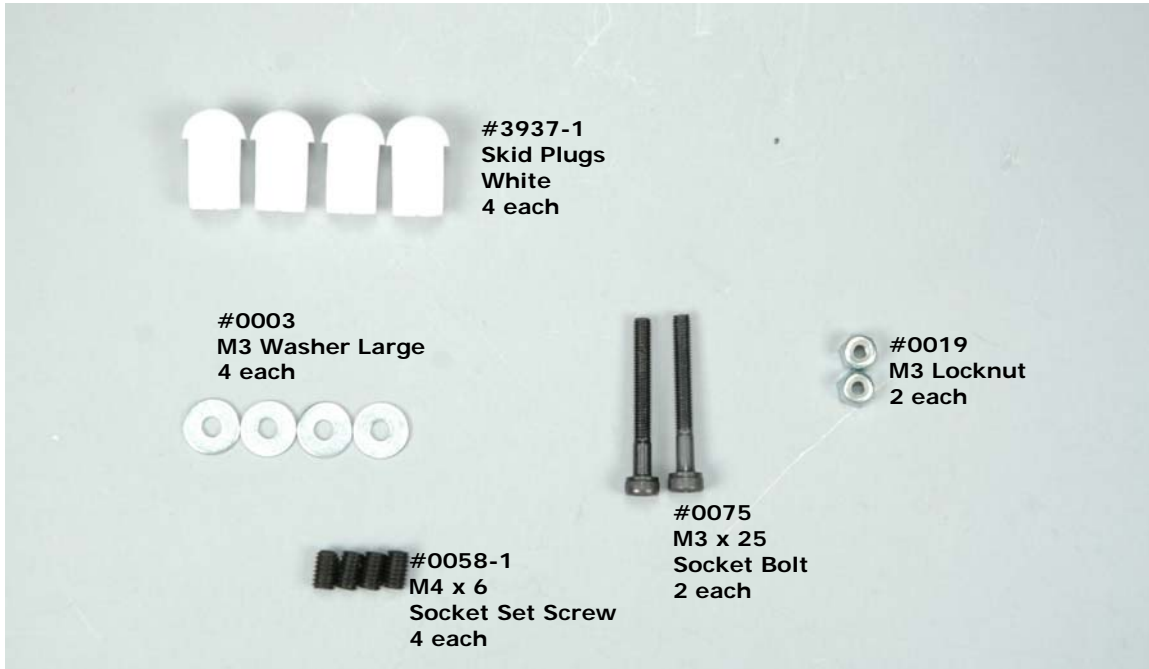

4C.1 – Assemble/Install Landing Gear/Frame Bottom Plate

Parts Relationship

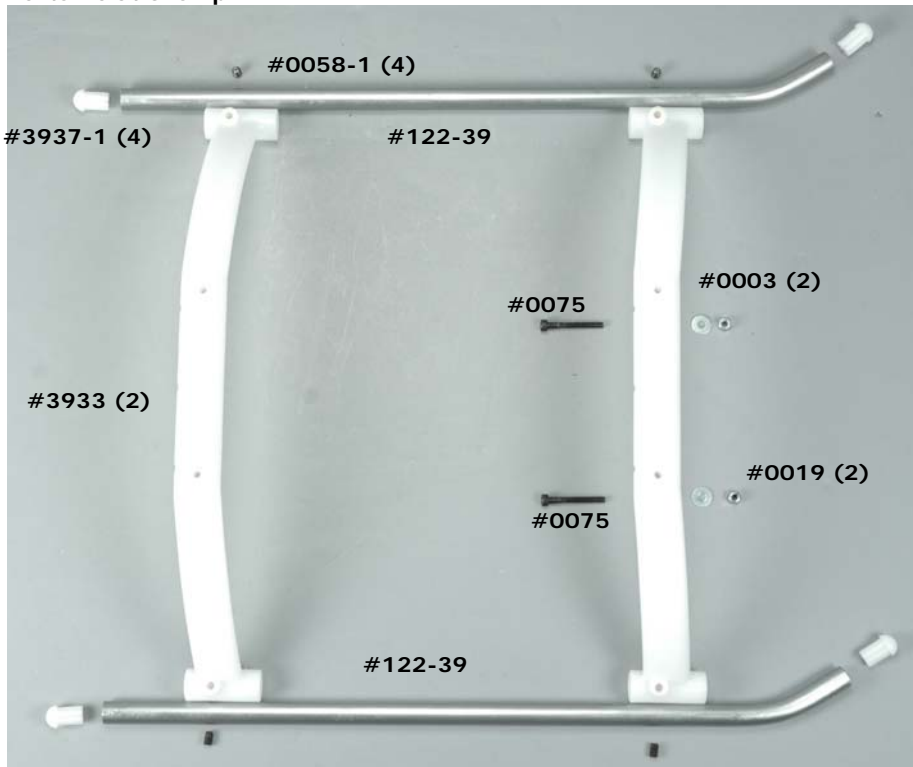

XCell Fury Extreme Assembly Manual

4C.1.a



4C.1.b

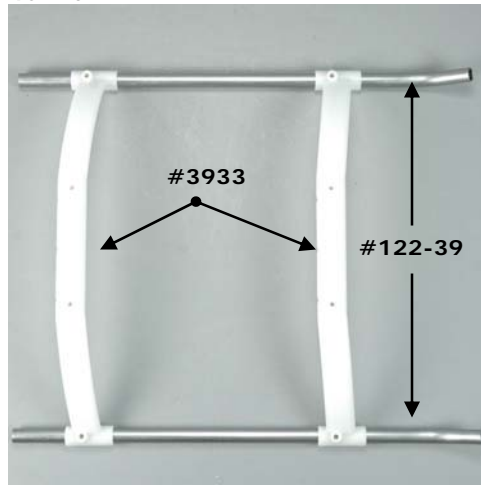

4C.1.c



4C.1.d

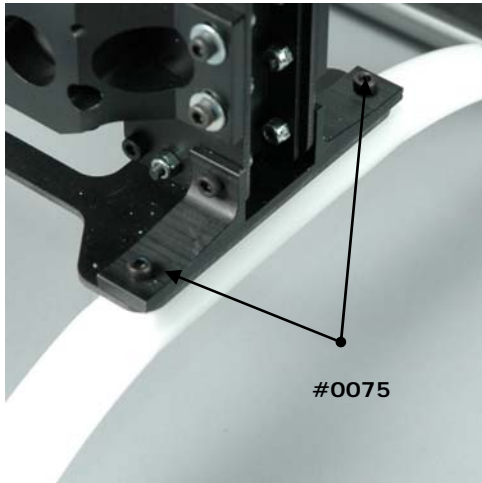

4C.1.e

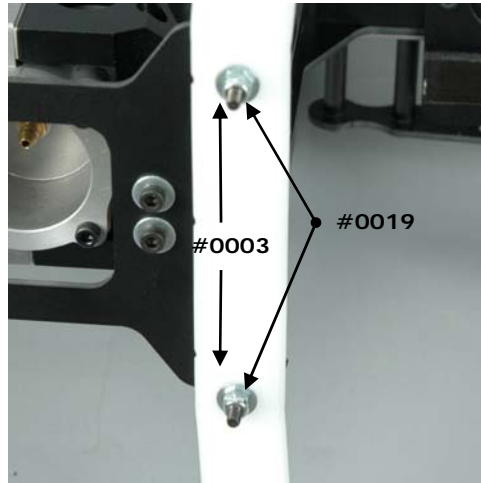

4C.1.f



4C.1.g

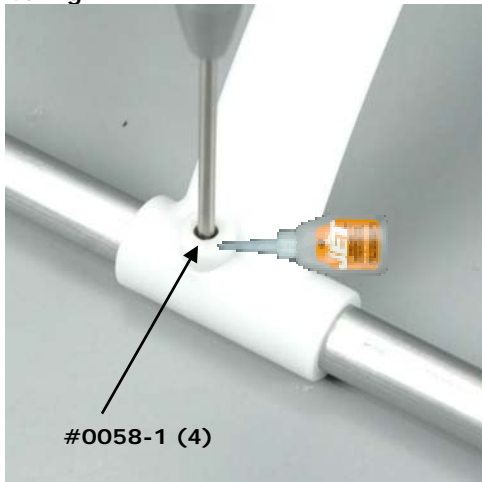

4C.1.h

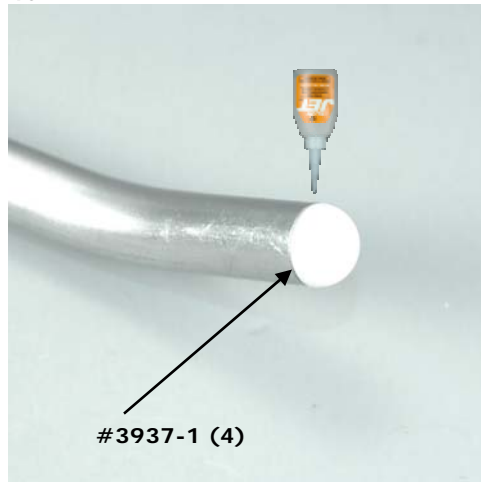

4C.1.i

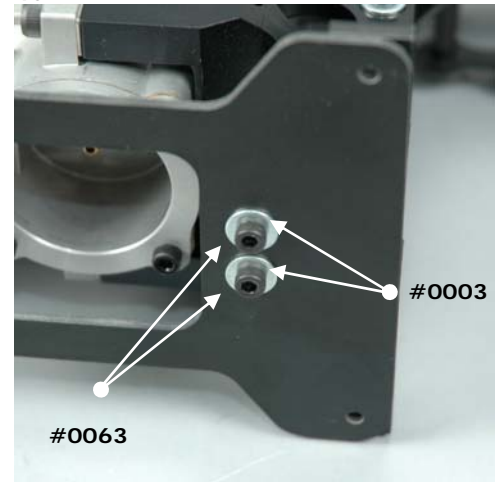

D) Fan Shroud Mounts - Bag #4D

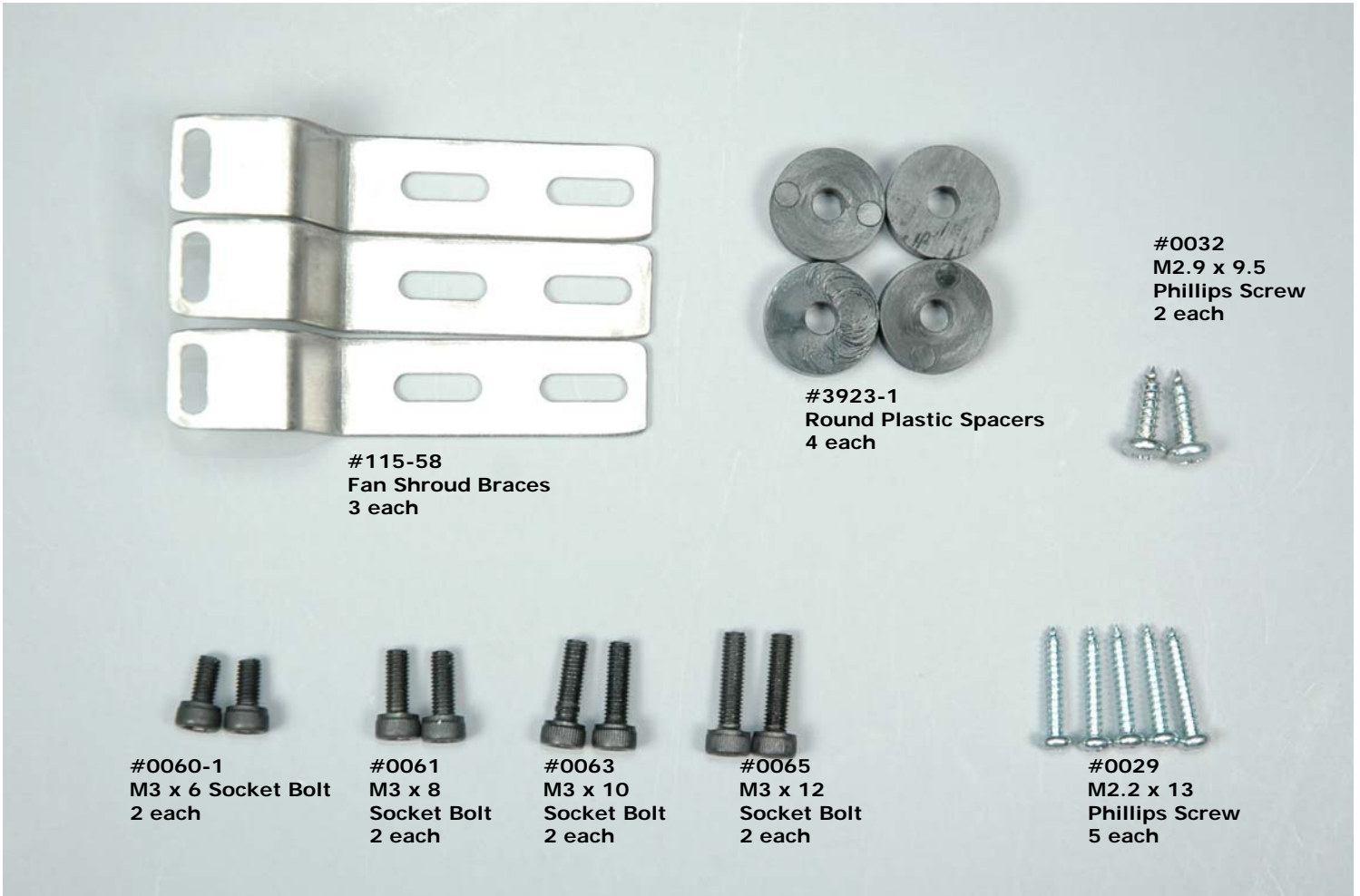

4D.2 – Assemble/Install Fan Shroud/Mounts

Parts Relationship

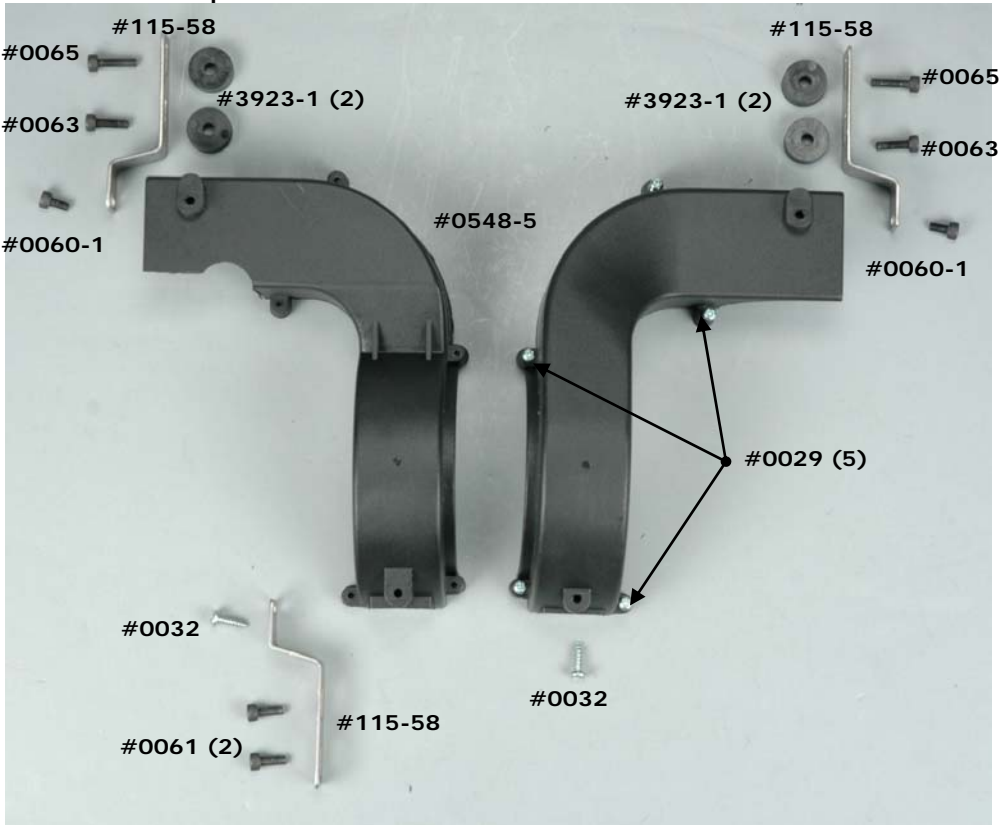

4D.2.a

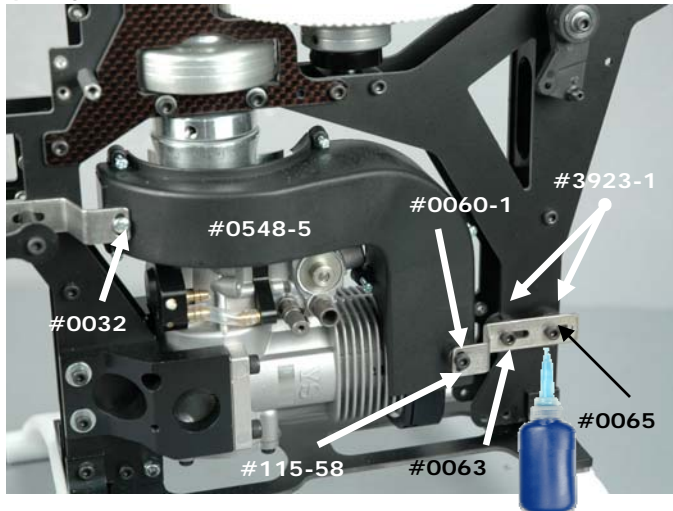

4D.2.b

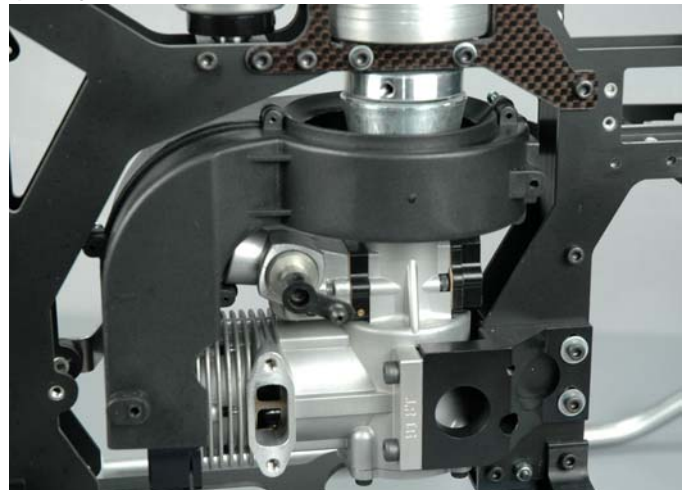

Building Notes – you may need to make adjustments to the fan shroud for carburetor clearance or for cylinder head or muffler mounts depending on your choices. Use a rotor grinder to remove material.

4D.2.d

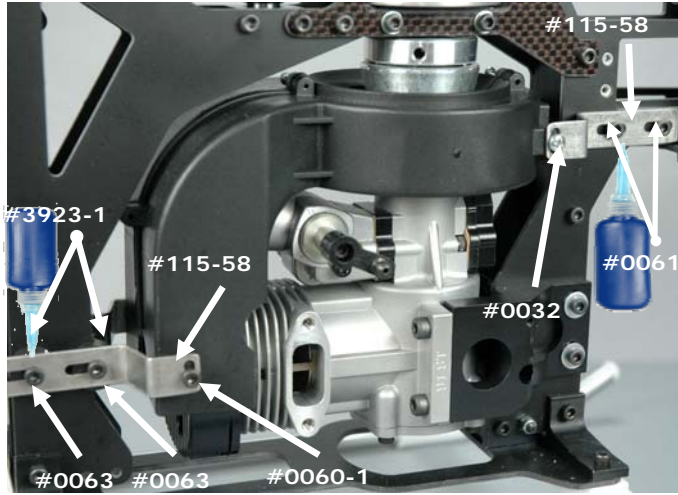

4D.3 – Install Muffler

4D.3.a



4D.3.b

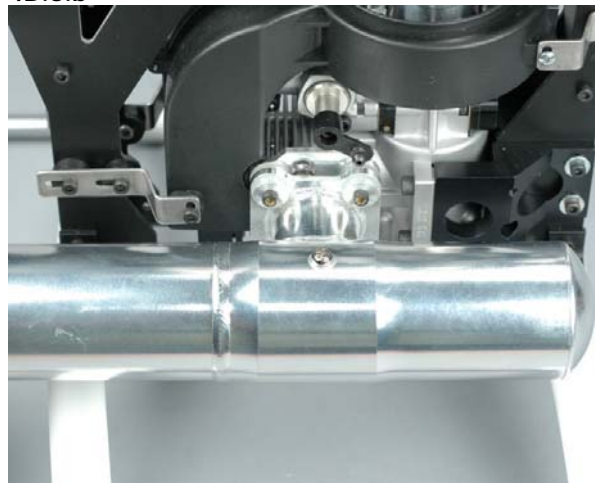

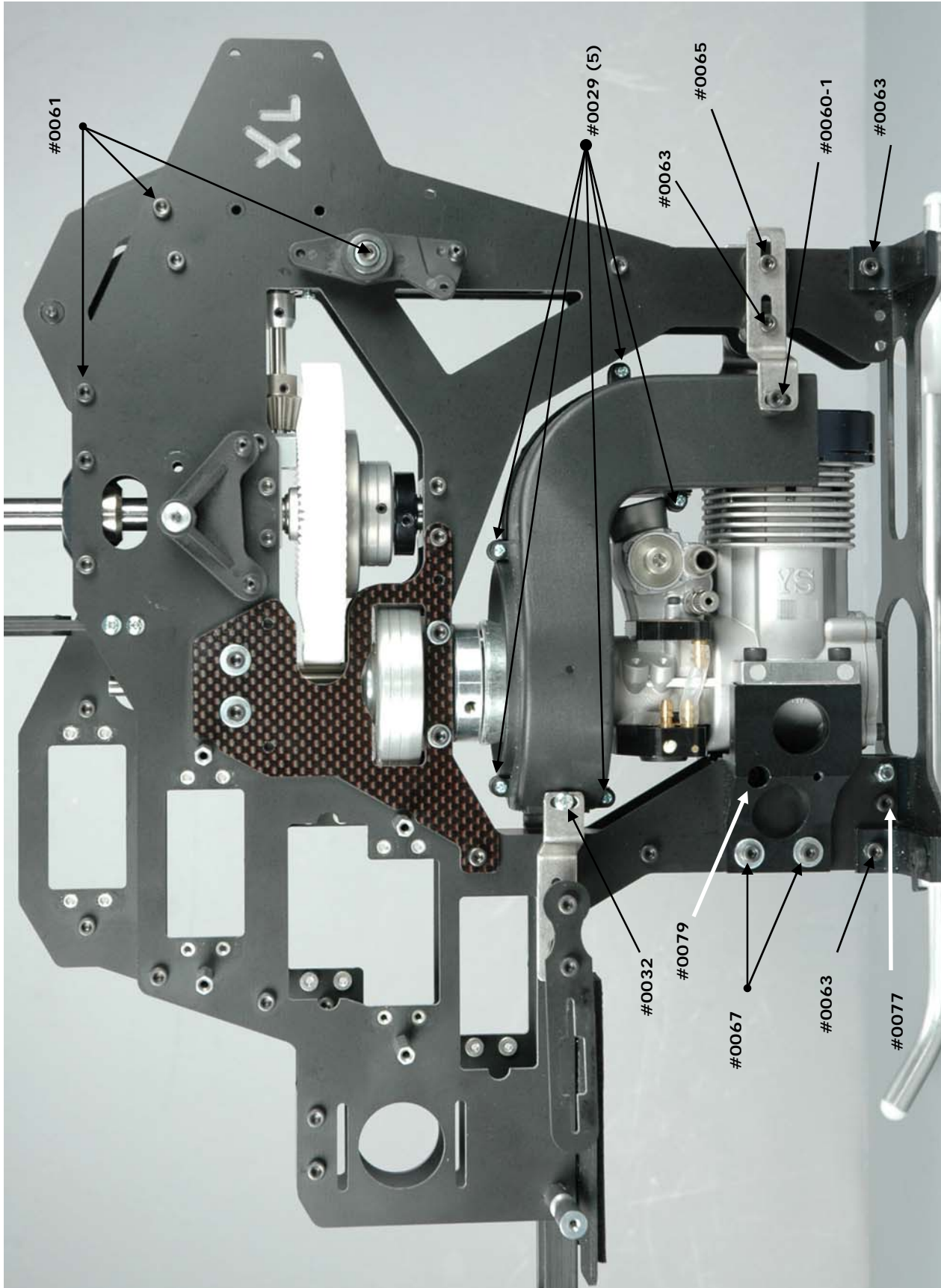

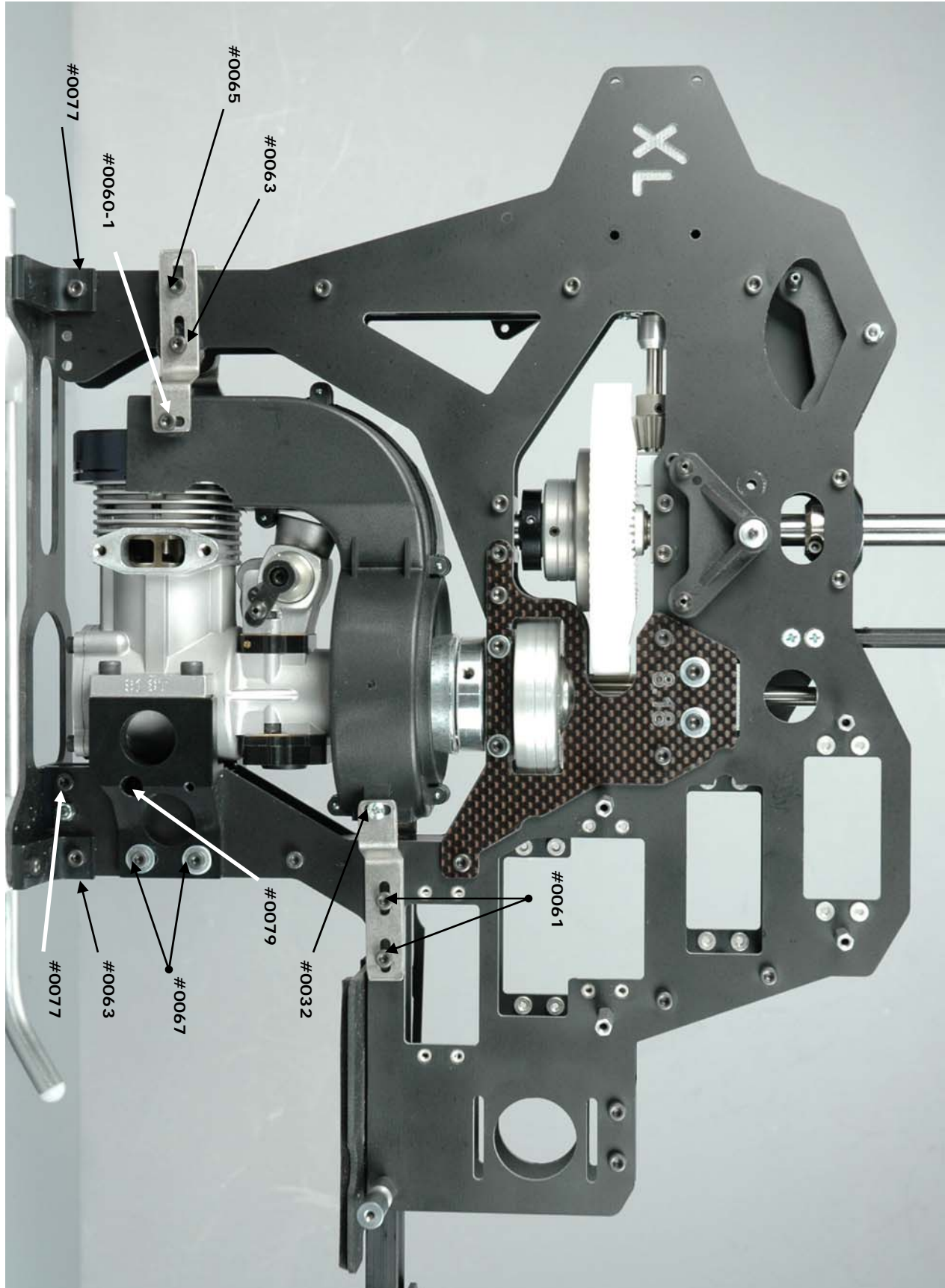

Step #5 – Fuel Tank

A) Fuel Tank - Bag 5A

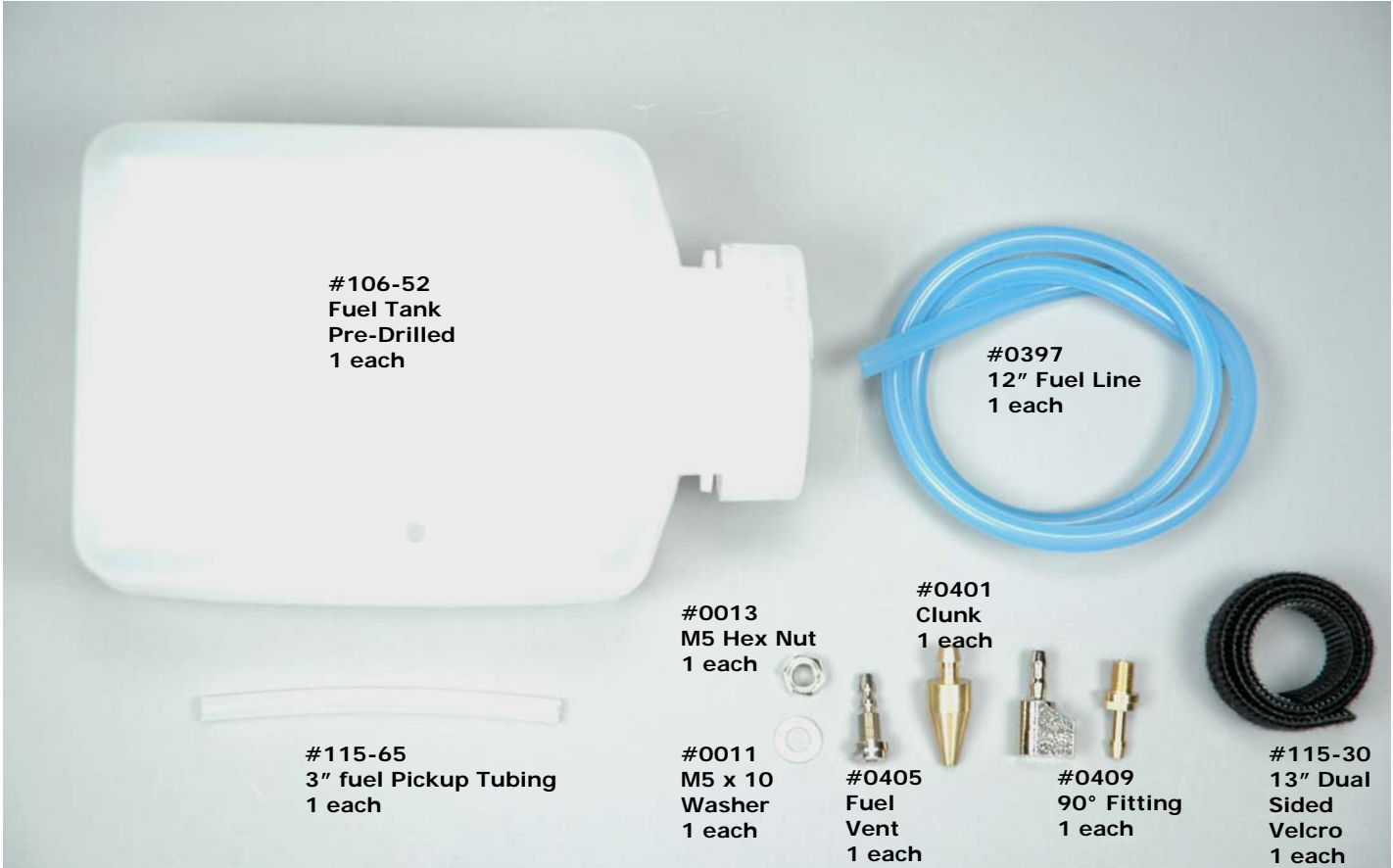

5A.1 - Assemble Fuel Tank

Parts Relationship



5A.1.a

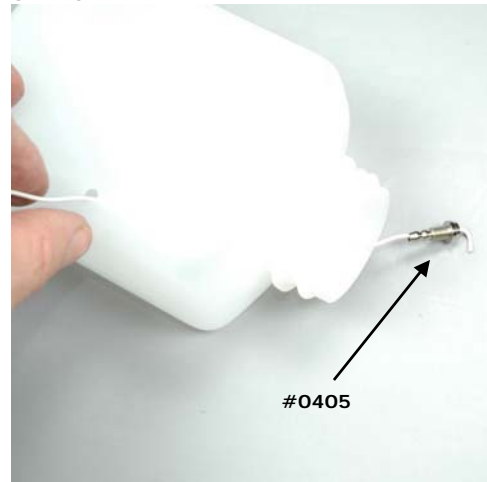

5A.1.b

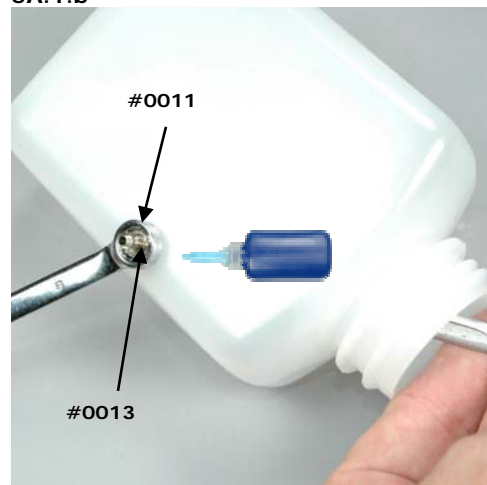

5A.1.c

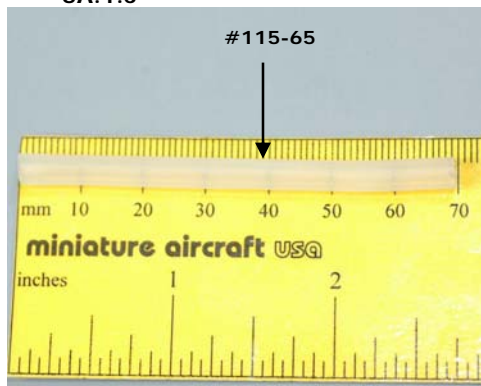

5A.1.d



XCell Fury Extreme Assembly Manual

5A.1.e



5A.1.f



5A.1.g

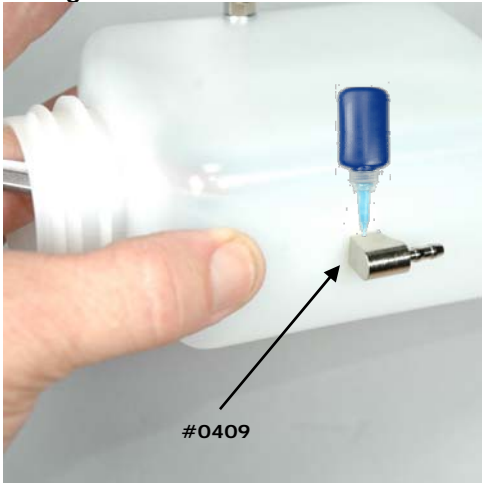

5A.1.h



5A.2 - Install Fuel Tank

5A.2.a



5A.2.b



5A.2.c



5A.2.d



5A.2.e

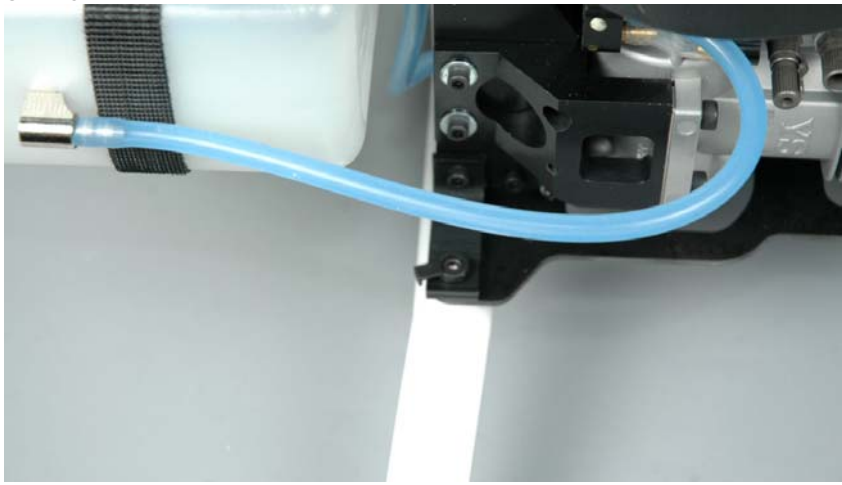

5A.2.f

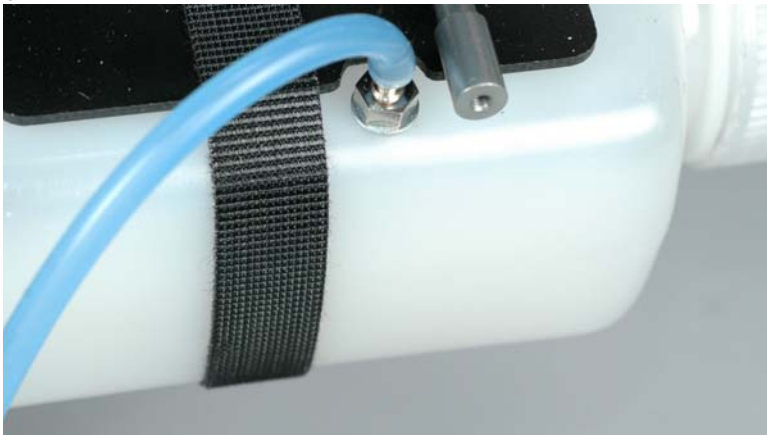

Step #6 – Swashplate/Washout Mixer

A) Swashplate - Bag #6A – Kit Specific

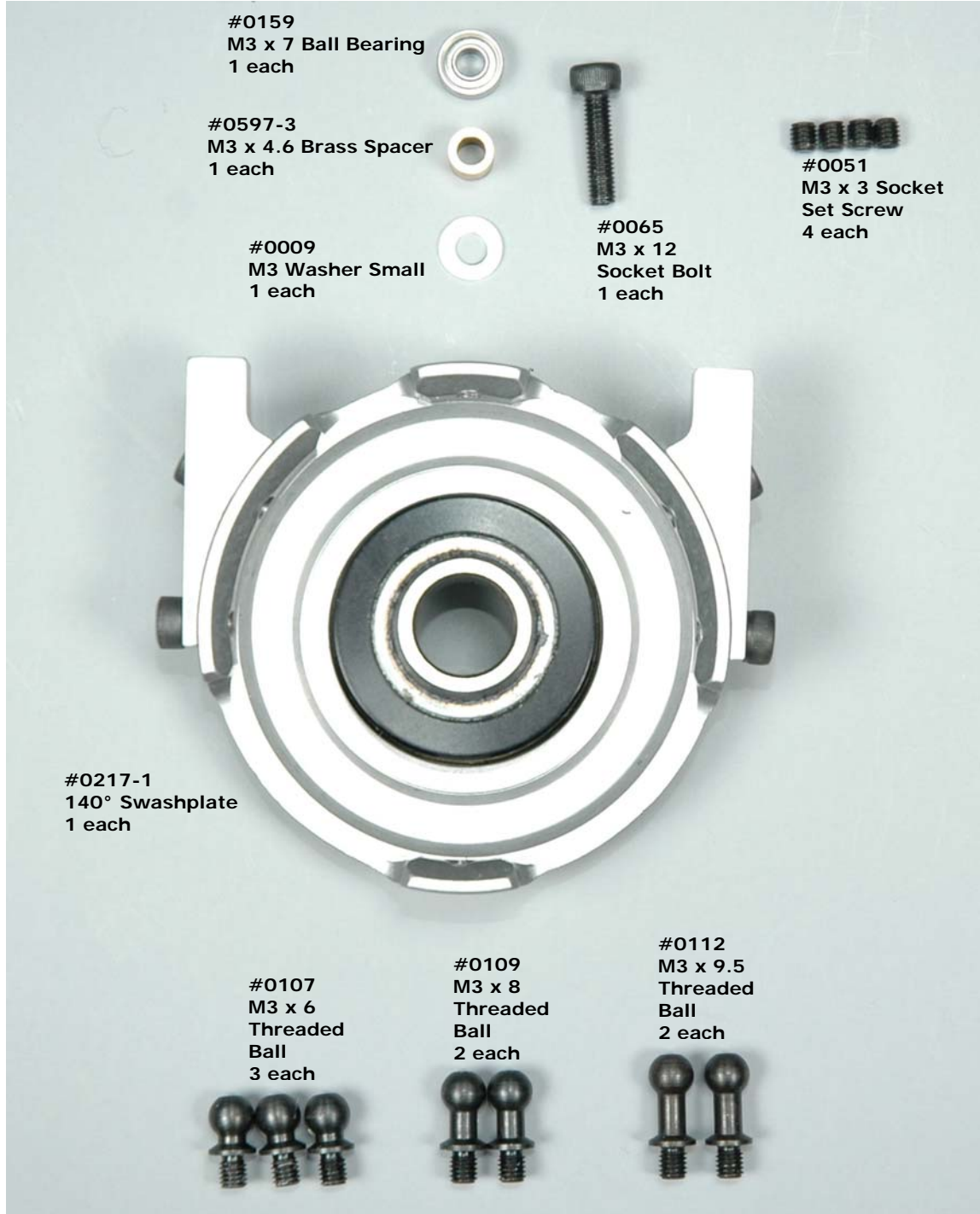

XCell Fury Extreme Assembly Manual

6A.1 - Assemble Swashplate

Parts Relationship

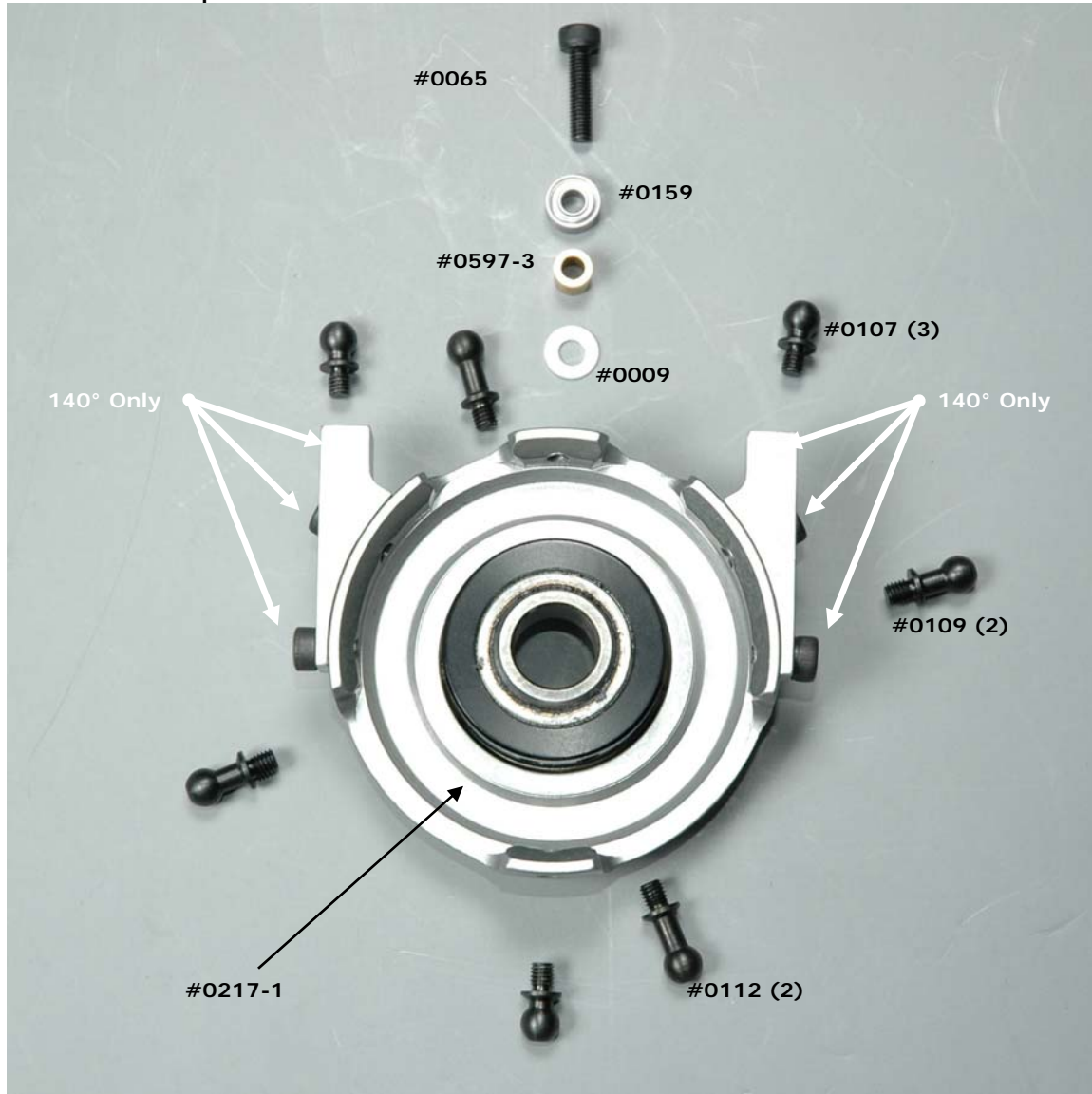

XCell Fury Extreme Assembly Manual

6A.1.a

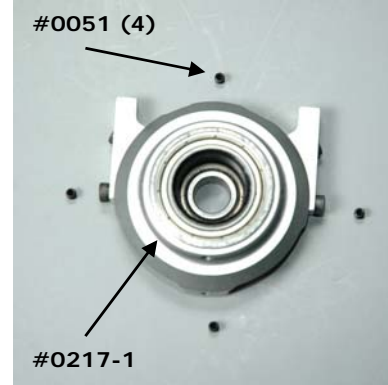
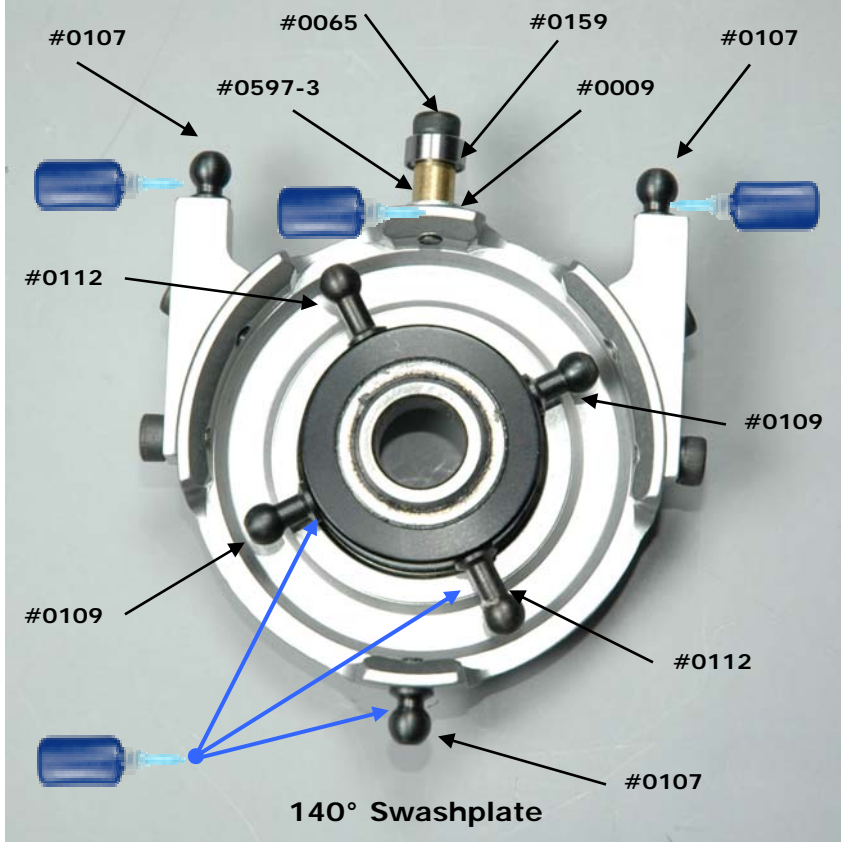

6A.1.b

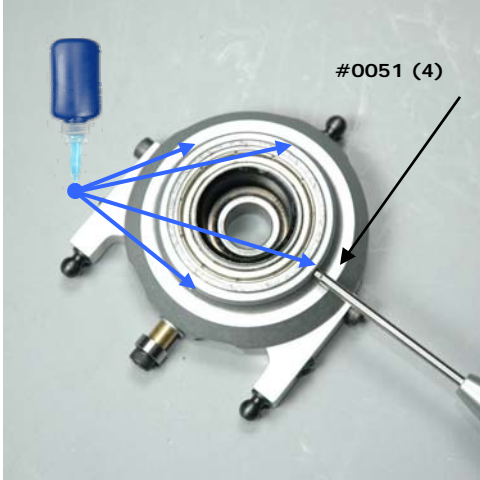

Building Notes - Flip the swashplate over to its bottom and locate the four 3mm threaded holes. These four holes and set screws are for periodically minimizing any free play that may develop as the swashplate bearing wears (excessive free play can cause inaccuracies in control inputs). Apply a small amount of blue thread lock to the threads of the set screws and using a 1.5mm allen driver, install each set screw loosely into these holes. The adjustment procedure is to rotate the inner swashplate ring within the outer ring and adjust the set screw until a slightly irregular or "notchy" feeling occurs, then loosen the set screw just enough to return the assembly to smooth operation. Repeat the procedure for each set screw. In most cases, this procedure should be done after every 20 gallons of fuel. *(This procedure can easily be done on an assembled model by simply disconnecting the related ball links.)*

6A.2 - Install Swashplate – 140° Kit

6A.2.a



6A.2.b

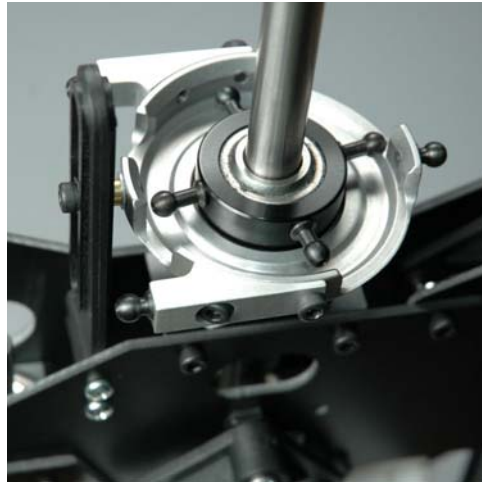

B) Washout Mixer - Bag #6B

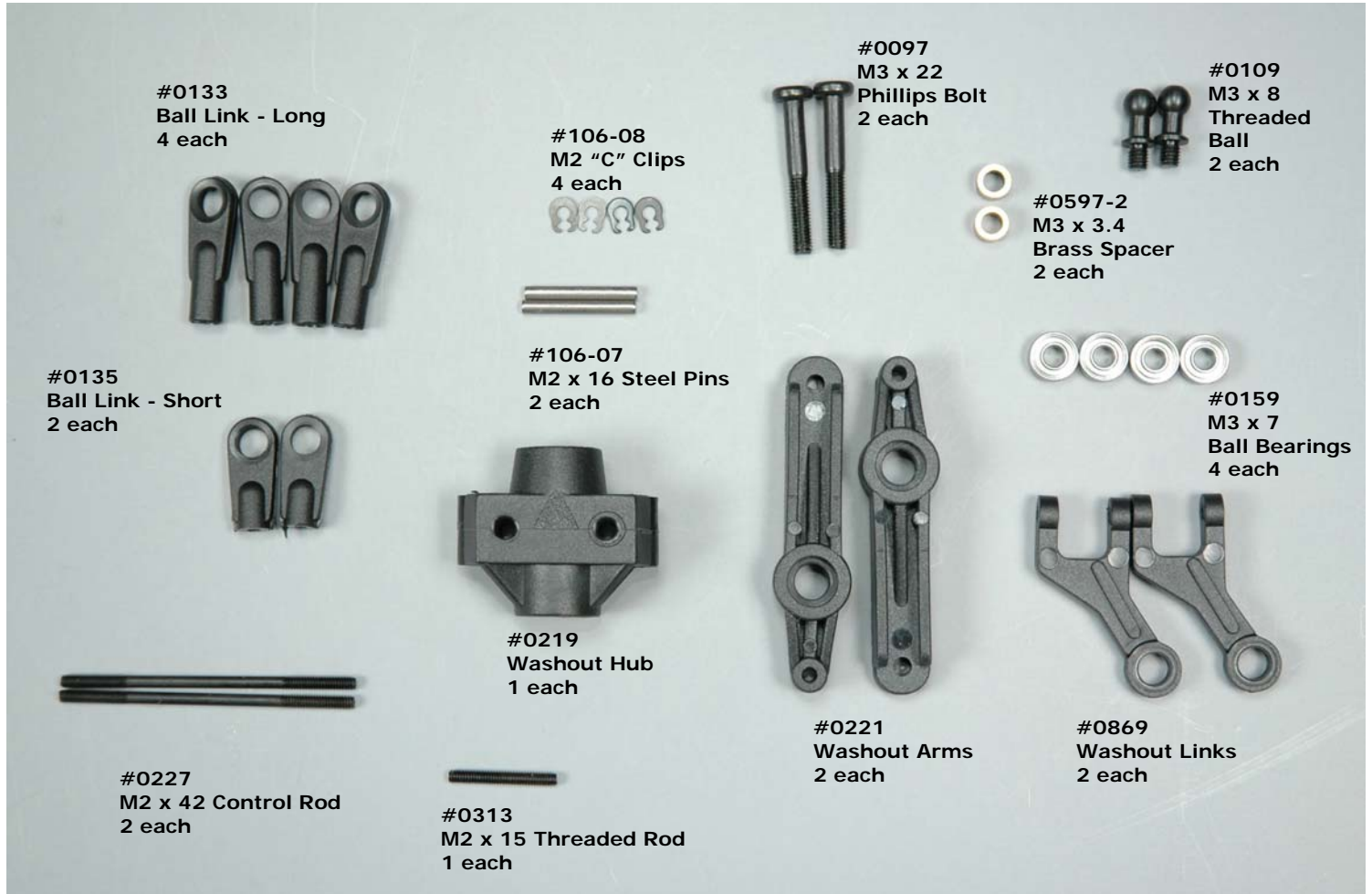

6B.1 - Assemble Washout Mixer

Parts Relationship

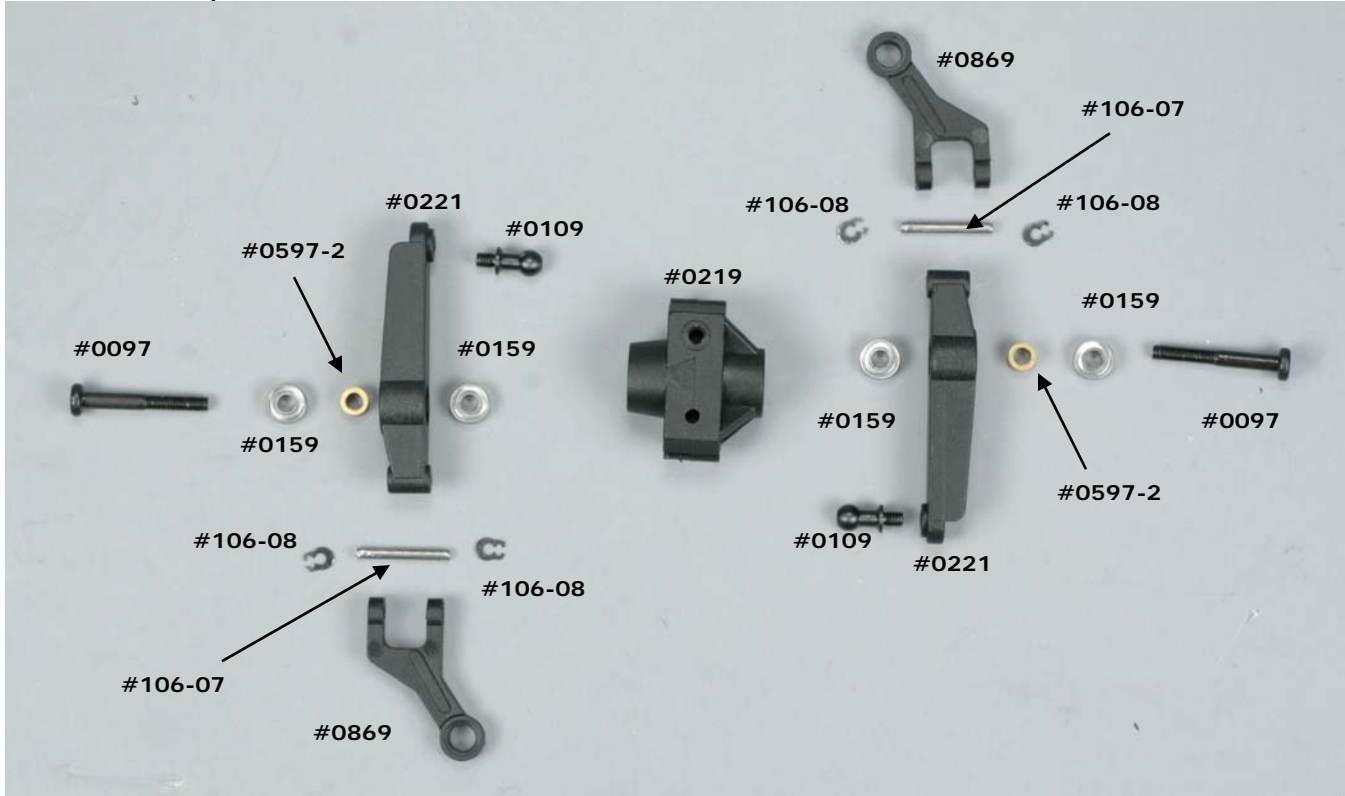

6B.1.a

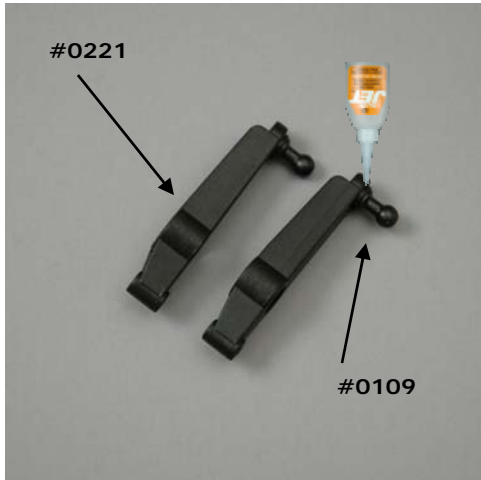

6B.1.b



6B.1.c



XCell Fury Extreme Assembly Manual

6B.1.d



6B.1.e



6B.1.f

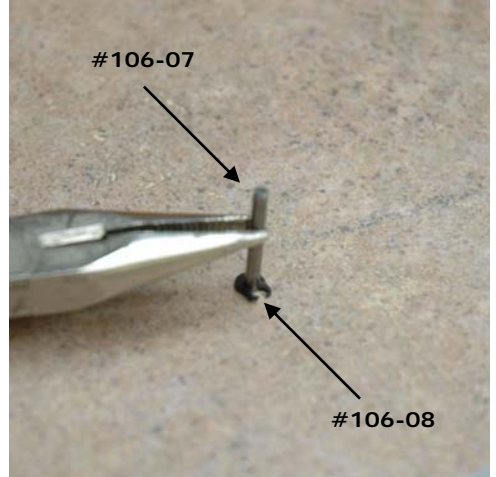

6B.1.g



6B.1.h



6B.1.i



6B.1.j



6B.1.k



6B.1.l



6B.1.m



6B.2 - Install Washout Mixer



6B.3 – Assemble Swashplate Control Rods

6D.3.a

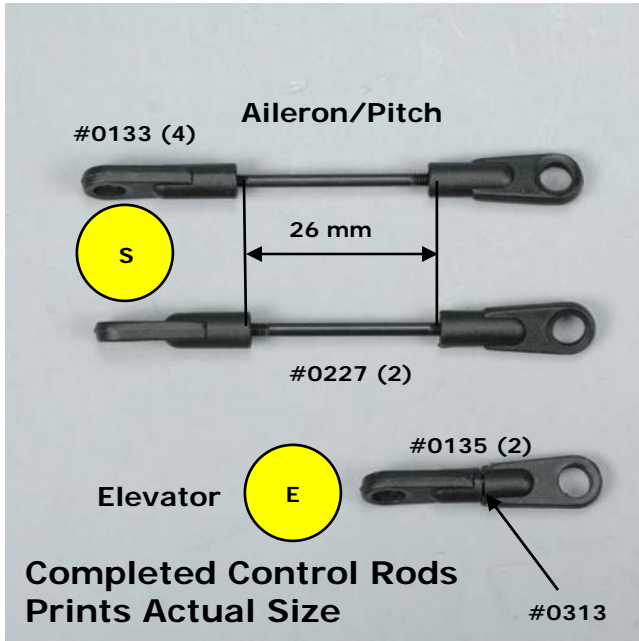

6B.4 – Install Swashplate Control Rods

6D.3.a

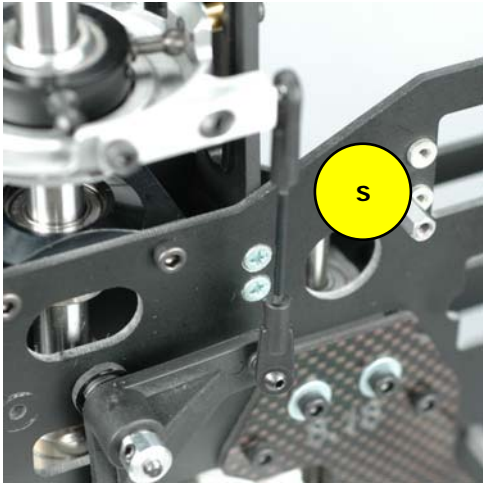

6D.3.b

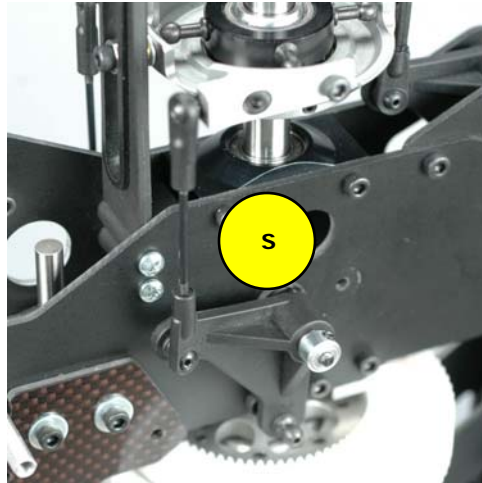

6D.3.c

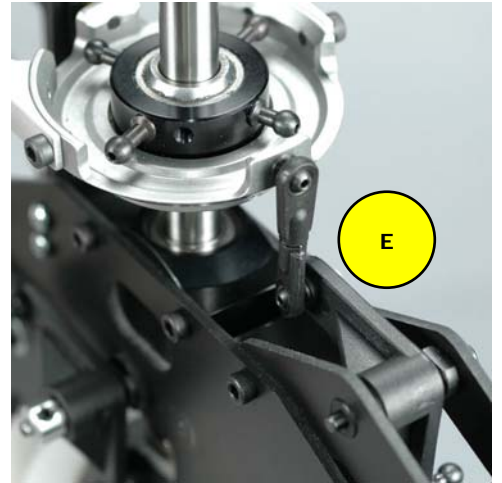

Step #7 – Control System/Canopy

A) Servo Mounts - Bag #7A

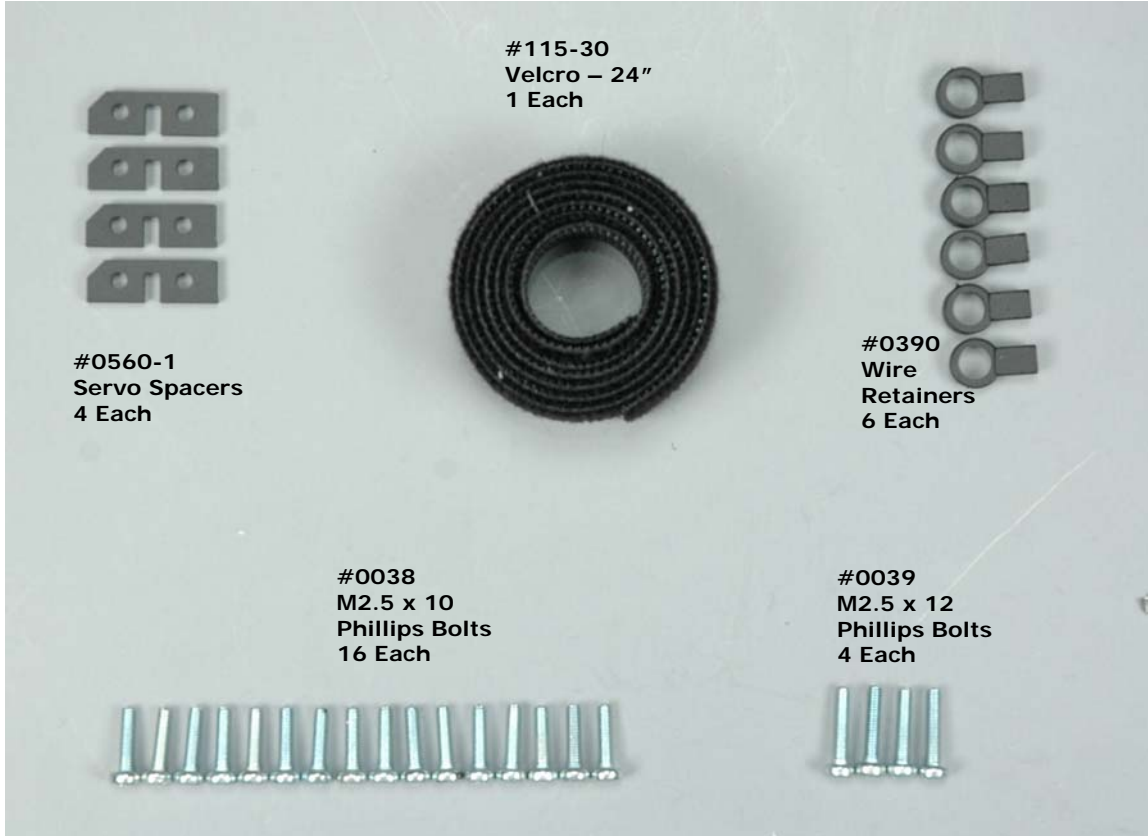

XCell Fury Extreme Assembly Manual

7A.1 – Install Servos/Radio Gear

Parts Relationship – Rudder, Aileron, Pitch

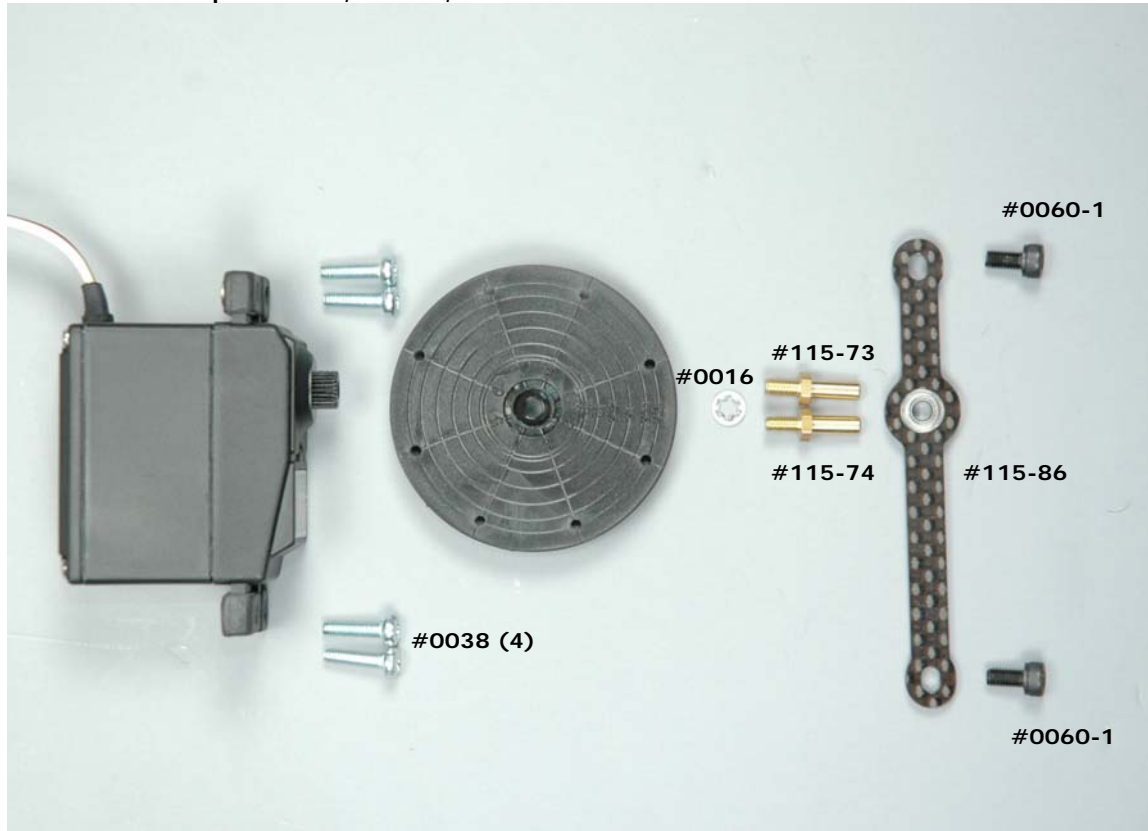

Parts Relationship – Elevator

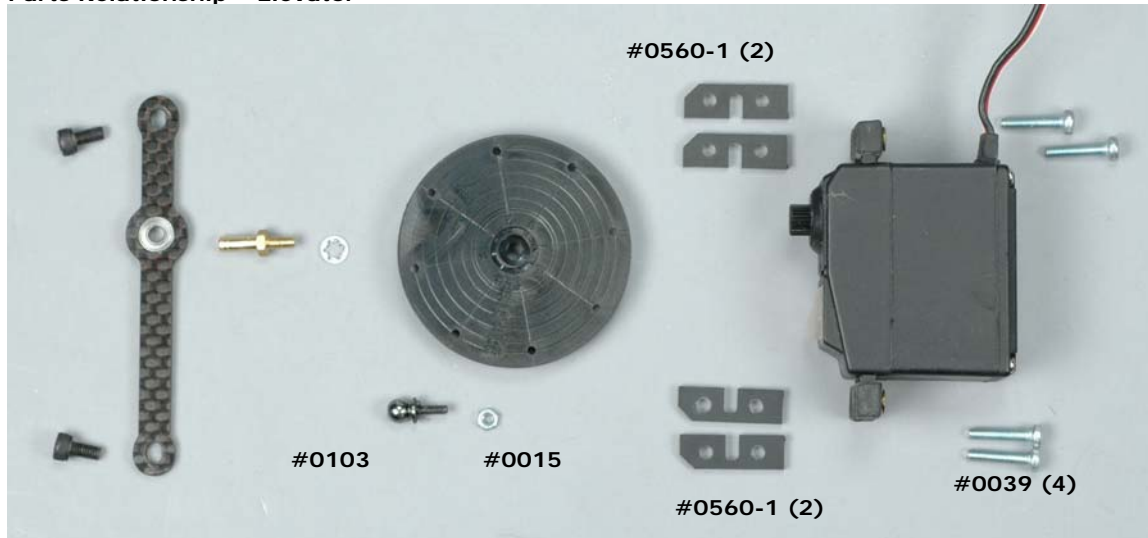

7A.1.a

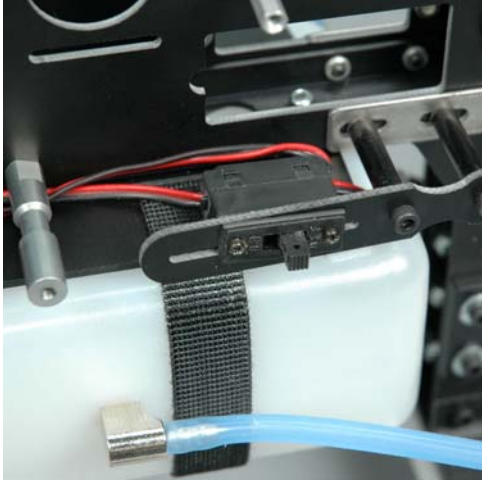

7A.1.b



7A.1.c

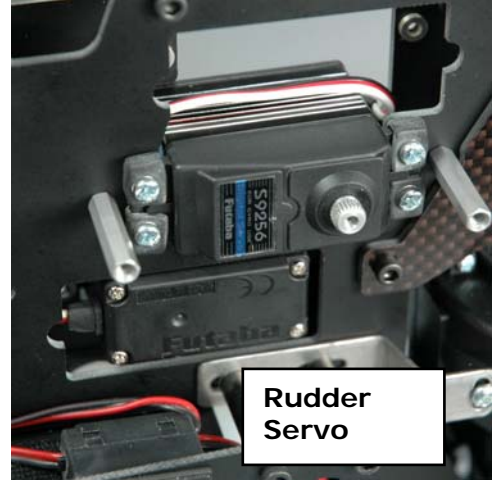

7A.1.d



7A.1.e



7A.1.f



7A.1.g



7A.1.h



7A.1.i

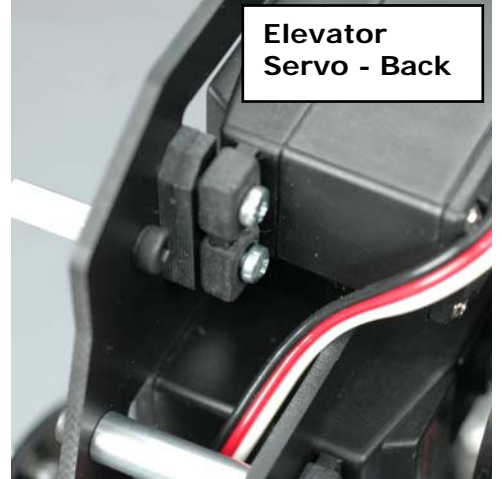

XCell Fury Extreme Assembly Manual

7A.1.j



7A.1.k

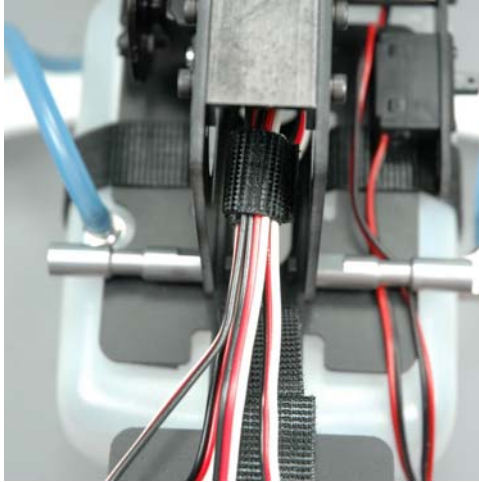

7A.1.l

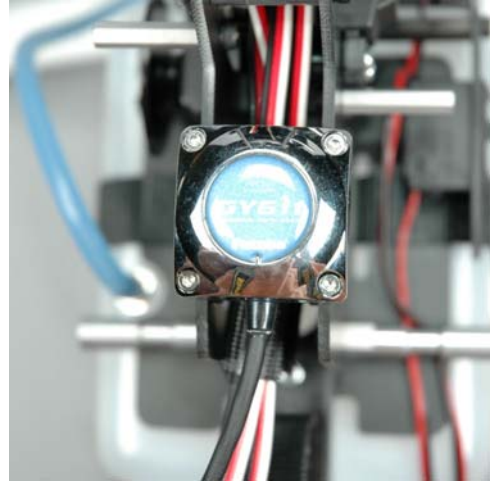

7A.1.m

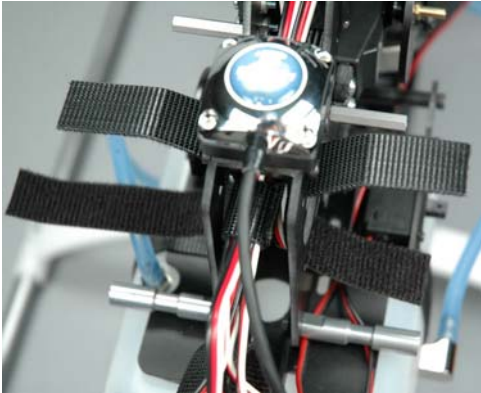

7A.1.n

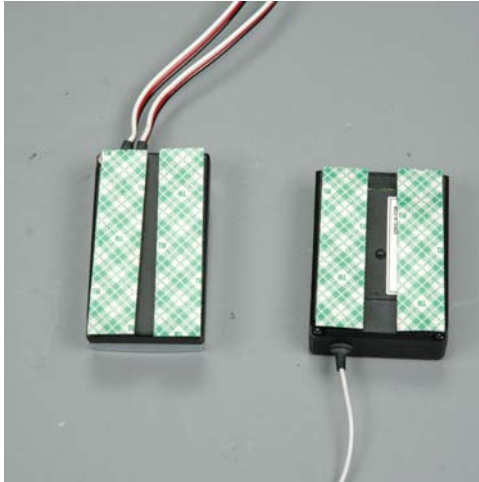

7A.1.o

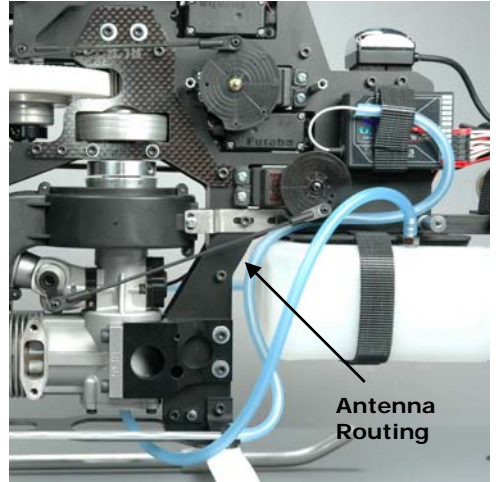

7A.1.p

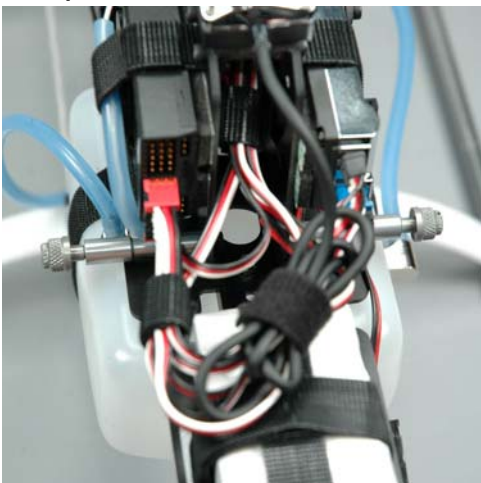

B) Ball Links - Bag #7B



Building Notes – These parts will be used in the next steps

C) Control Rods - Bag #7C

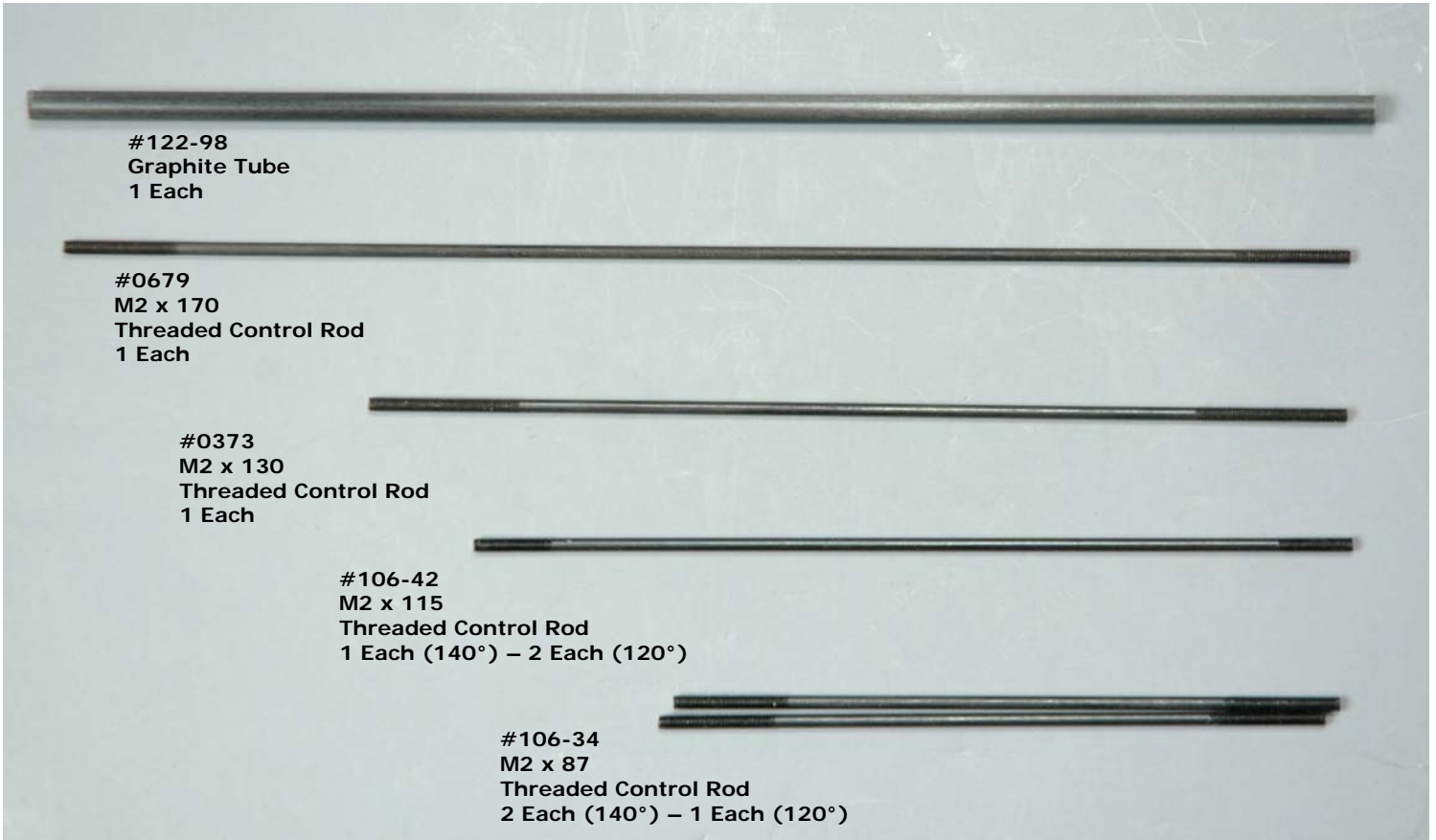

7C.1 – Assemble Servo Control Rods

7C.1.a

7C.1.b



7C.1.c

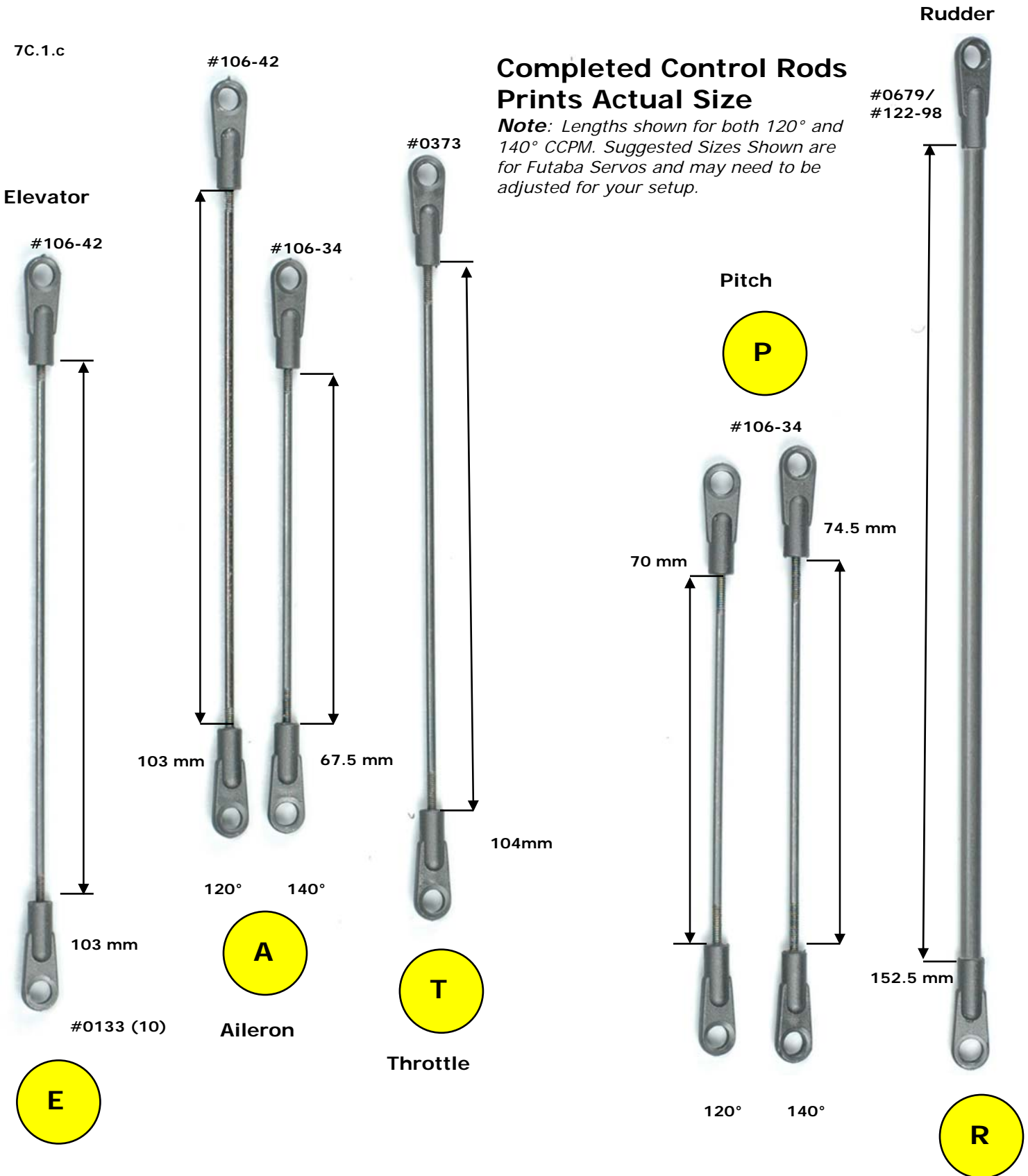

D) Servo Supports - Bag #7D

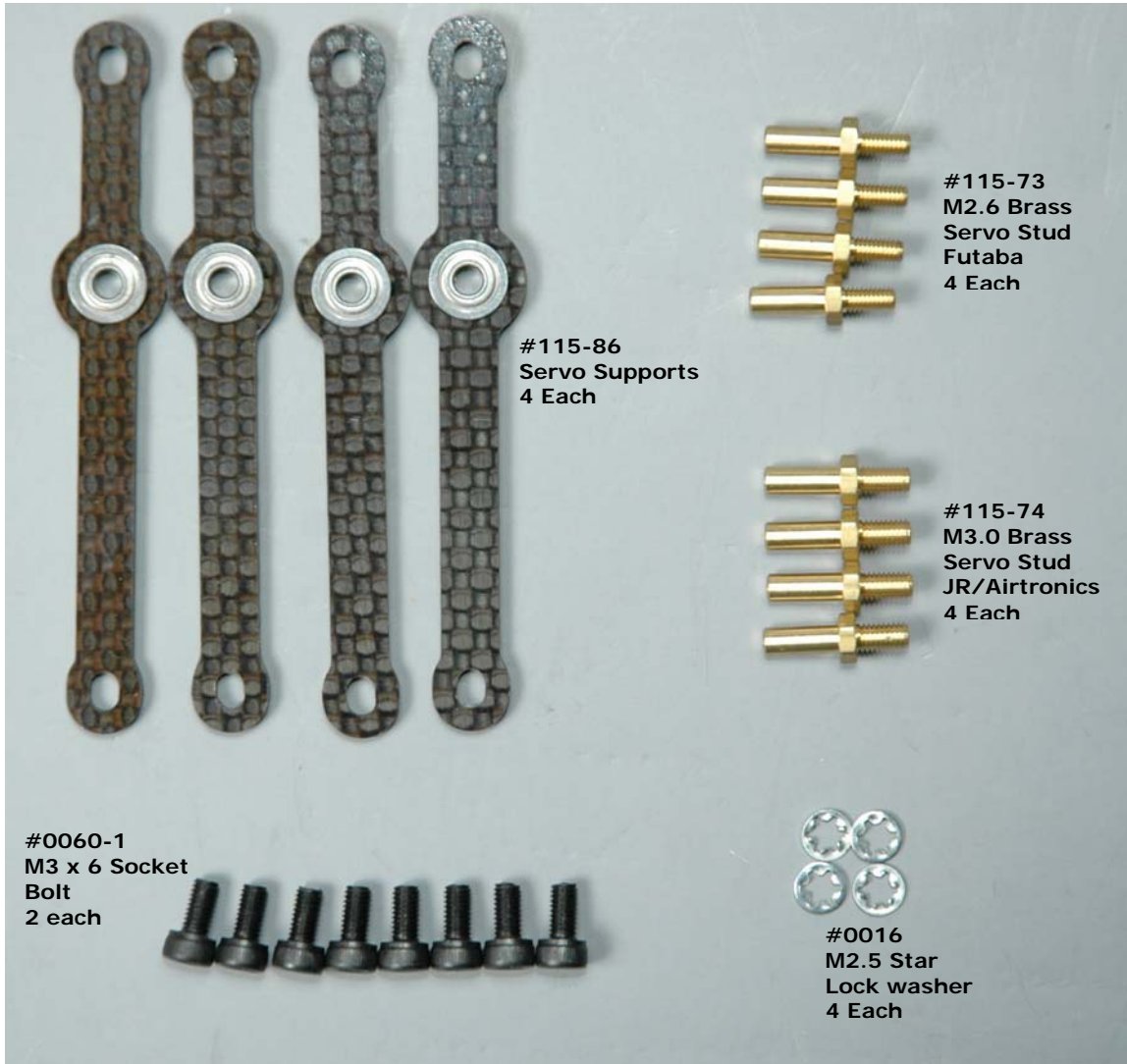

7D.1 – Assemble/Install Servo Wheels

7D.1.a

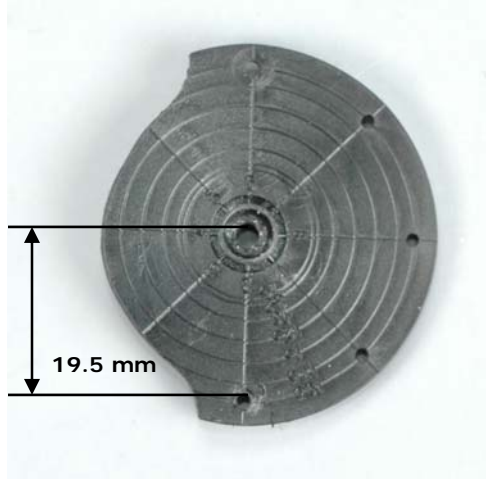

7D.1.b

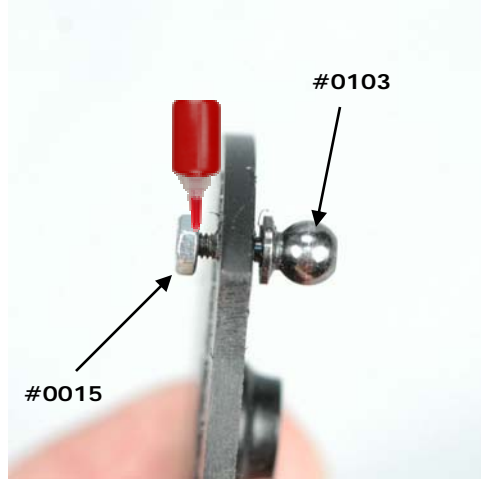

7D.1.c

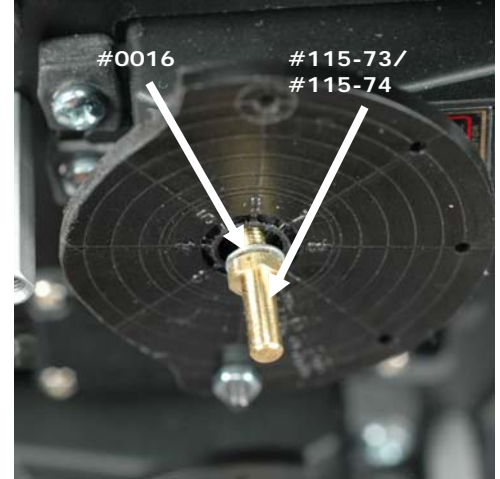

XCell Fury Extreme Assembly Manual

7D.1.d

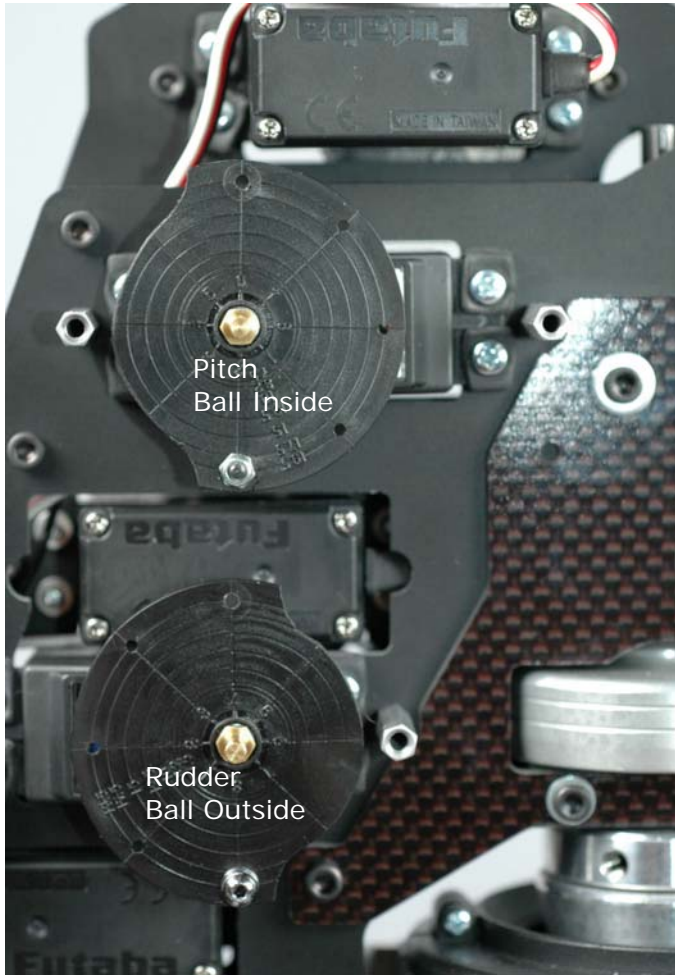

7D.1.e

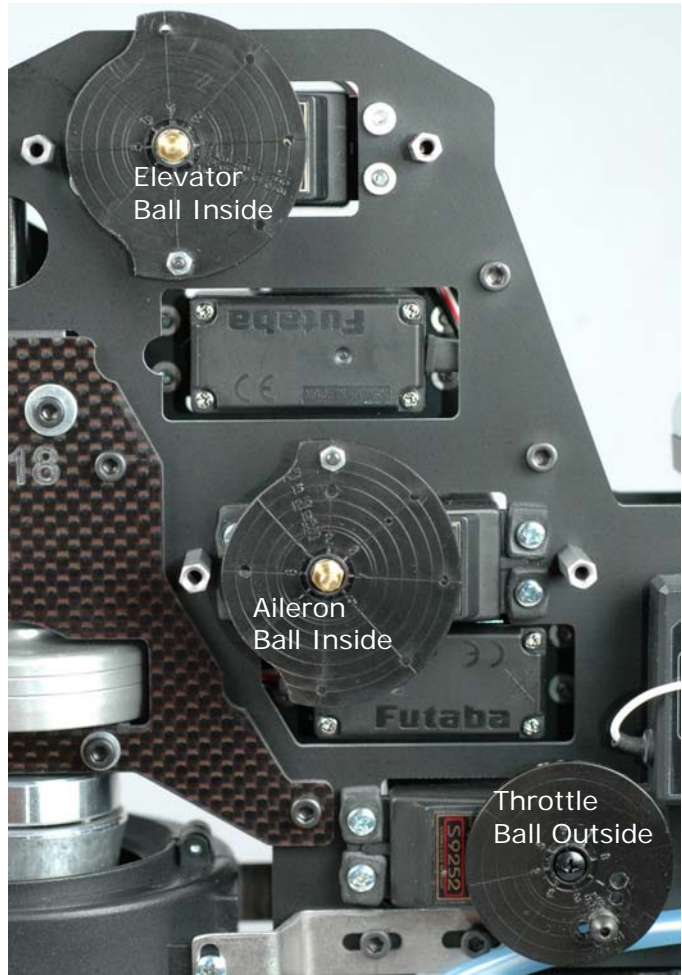

7D.2 – Install Servo Control Rods

7D.2.a

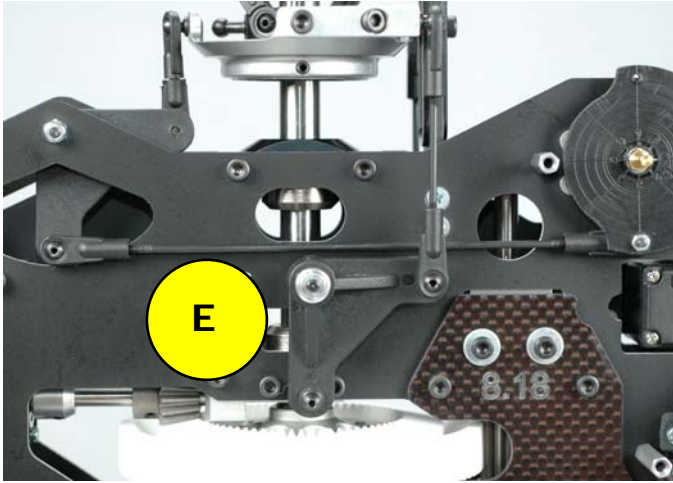

7D.2.b

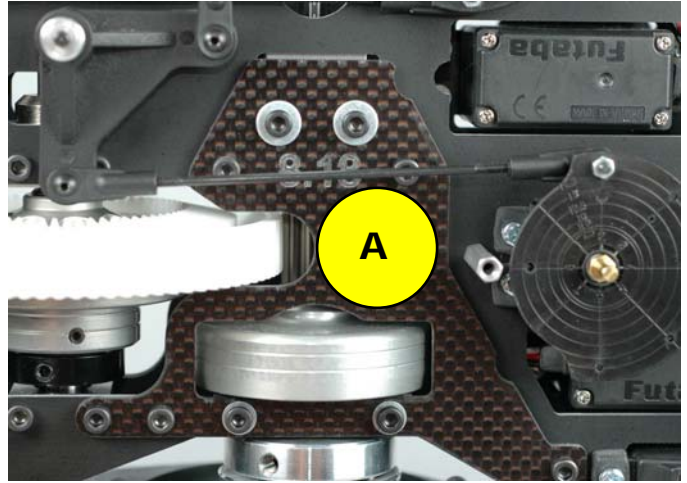

7D.2.c

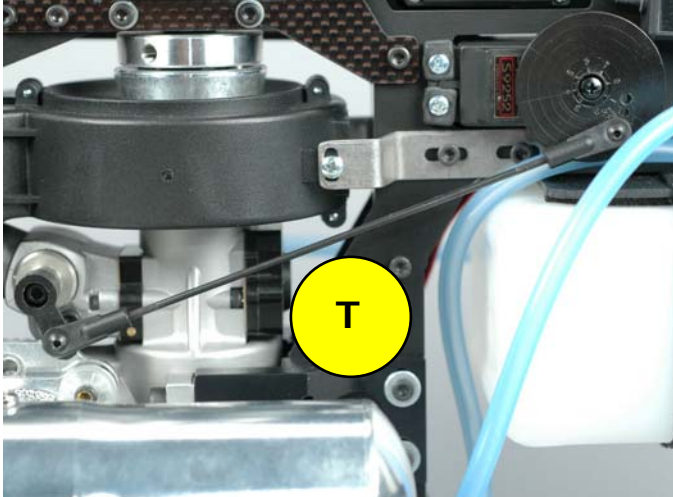

7D.2.d

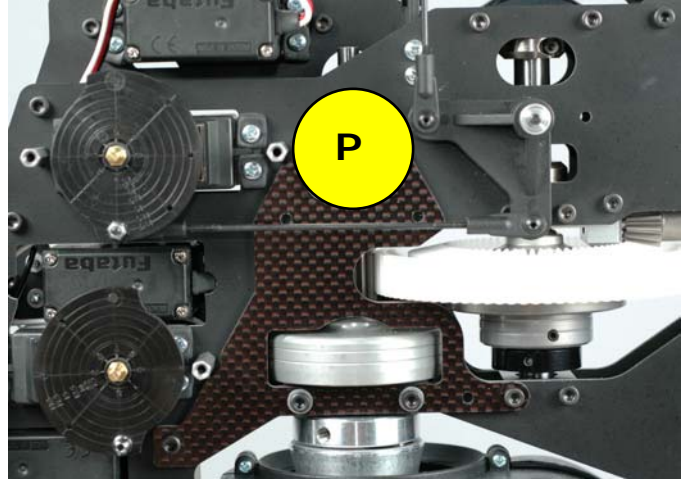

7D.2.e

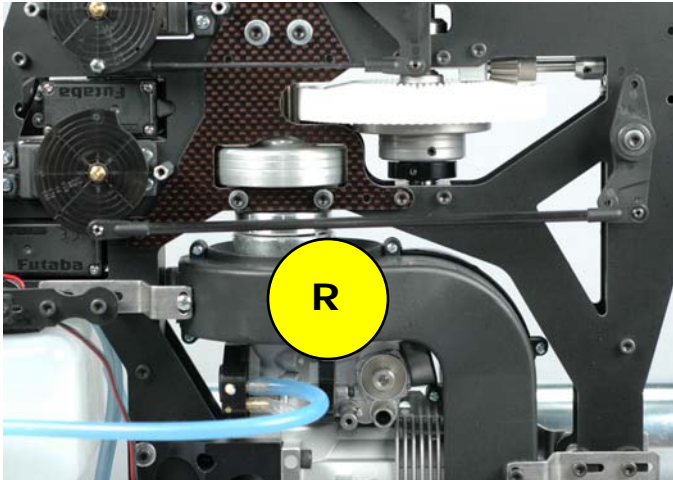

7D.3 – Install Servo Supports

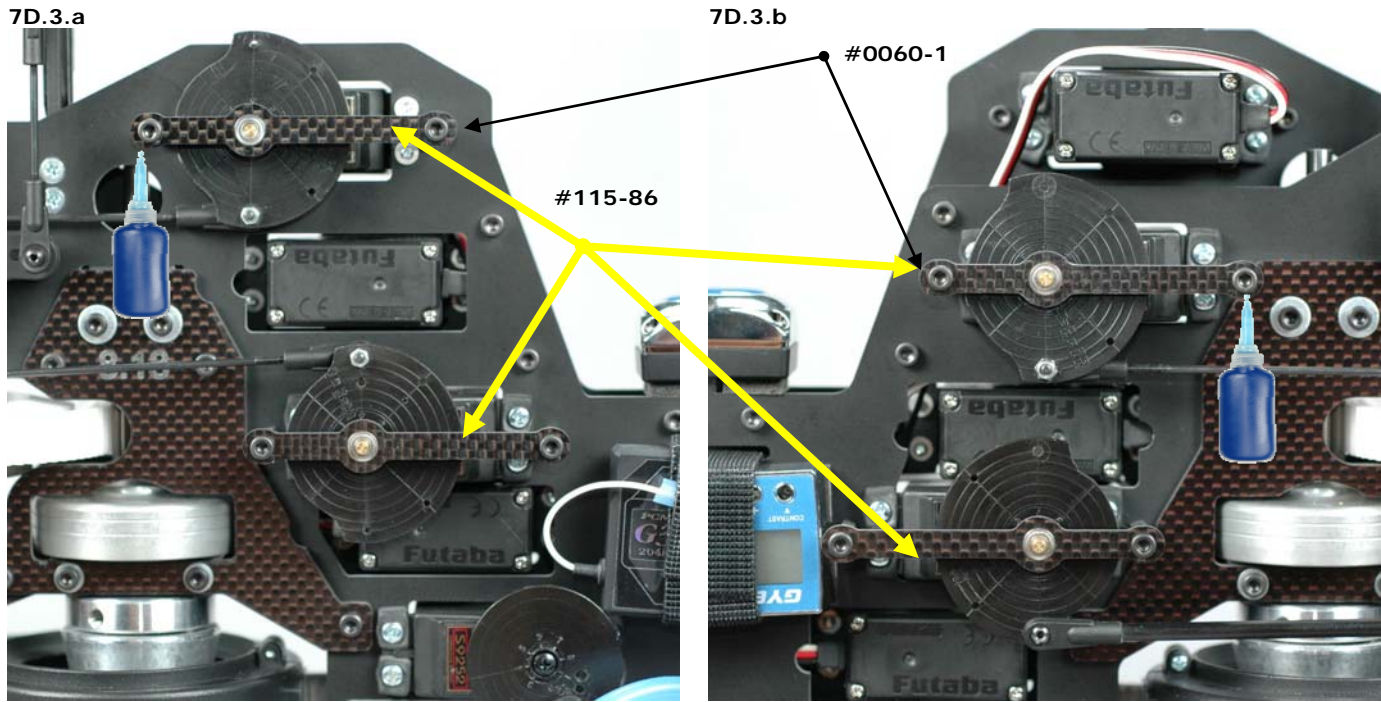

E) Canopy Mounts - Bag #7E



7E.1 – Assemble Canopy Knobs

7E.1.a



F) Canopy – Box Contents



7F.1.a

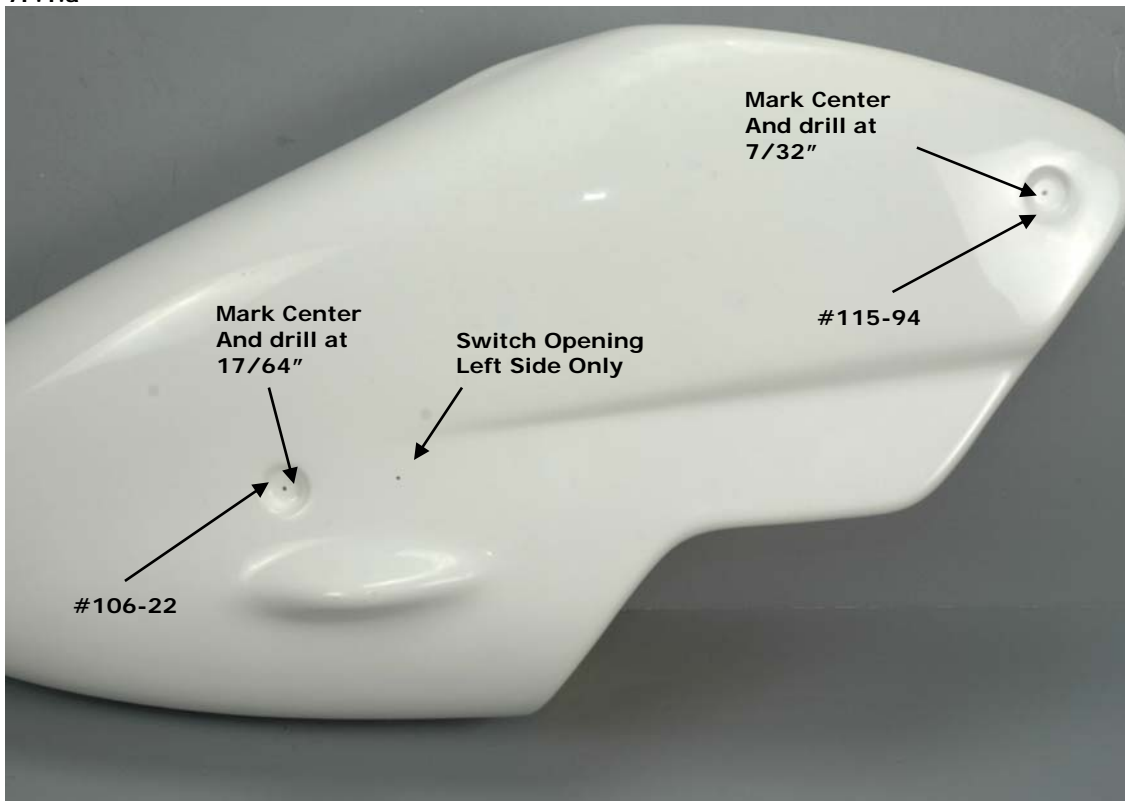

7F.1 – Prepare Canopy

7F.1.b

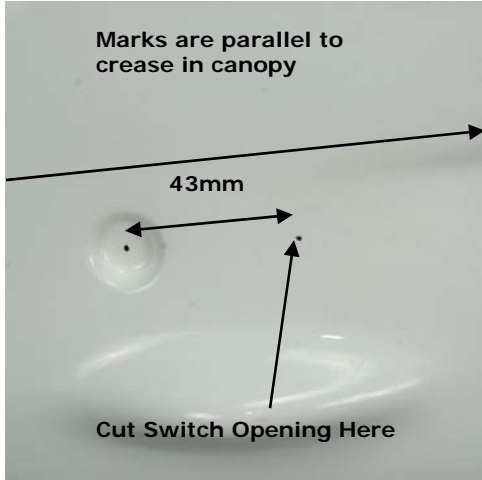

7F.1.c



7F.1.d



7F.1.e



7F.1.f



7F.1.g

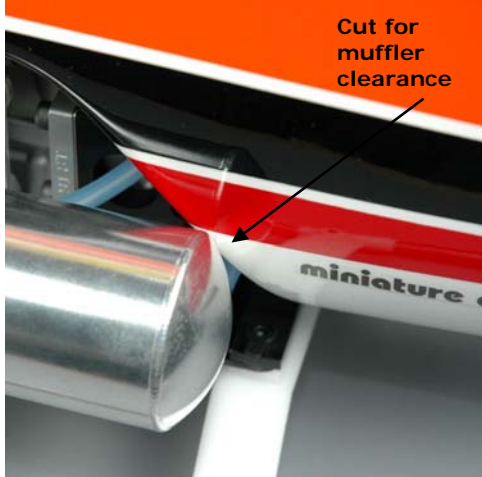

Step #8 – Rotor Head

A) Head Block - Bag #8A

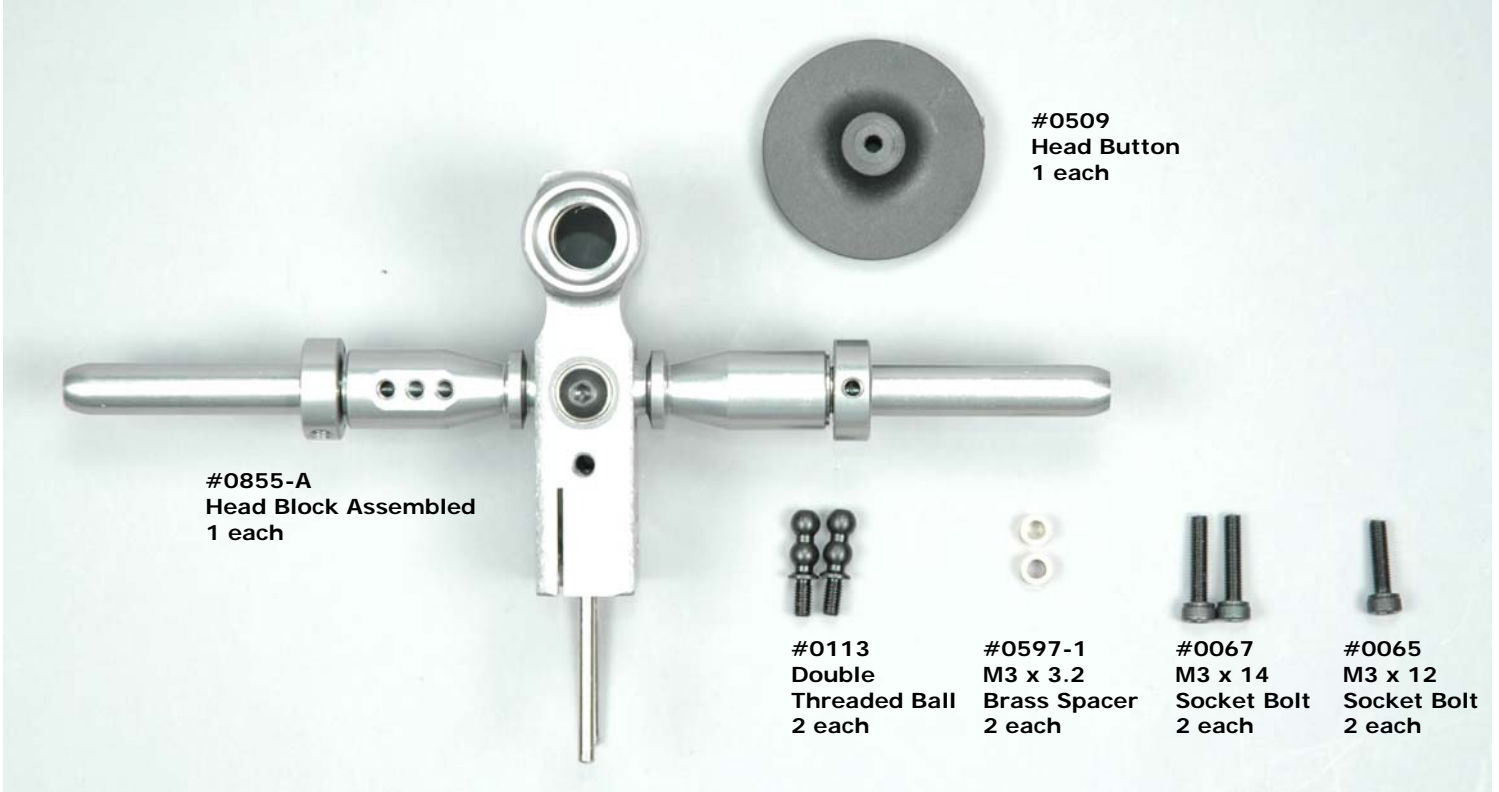

8A.1 - Head Block Assembly

Parts Relationship

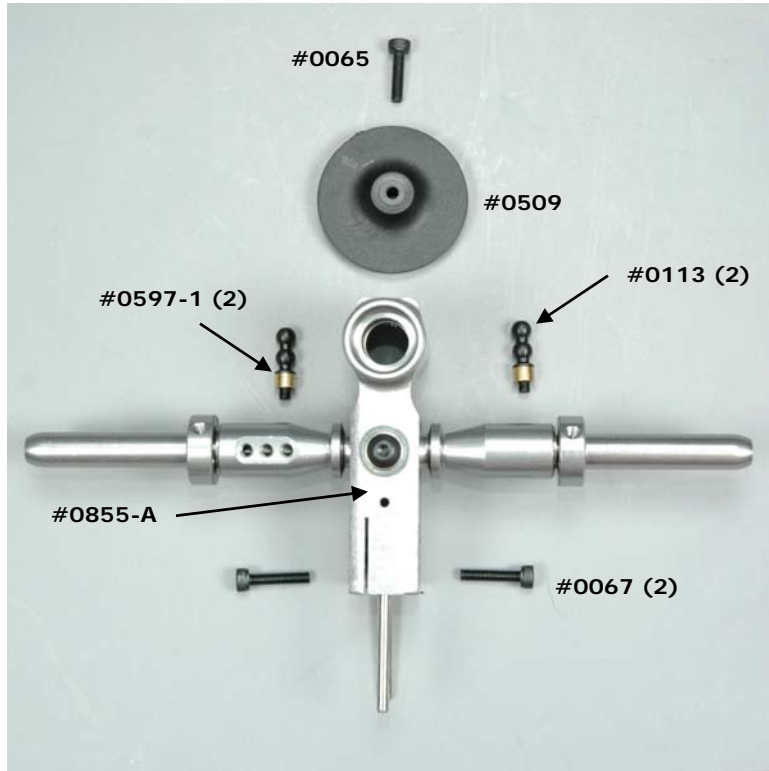

8A.1.a

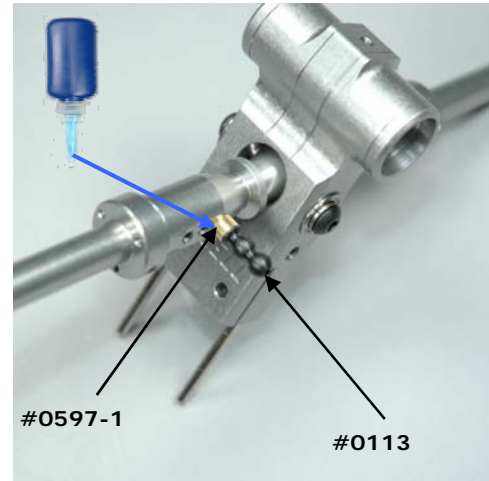

8A.1.b

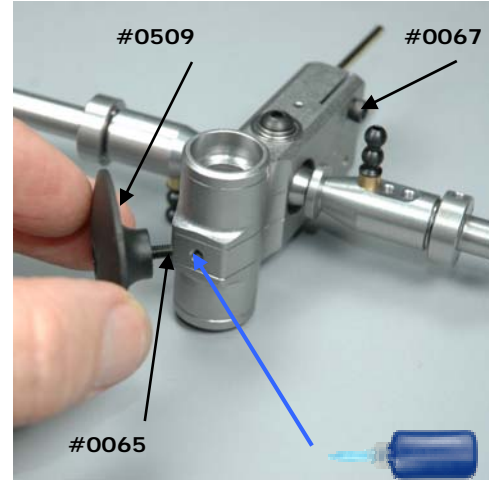

Building Notes – install the two #0113 control balls on the inside holes of the flybar crossbar.

Install the two #0067 bolts in the clamp holes on the bottom of the head block. Don't use thread lock at this time.

B) Blade Grips - Step #8B

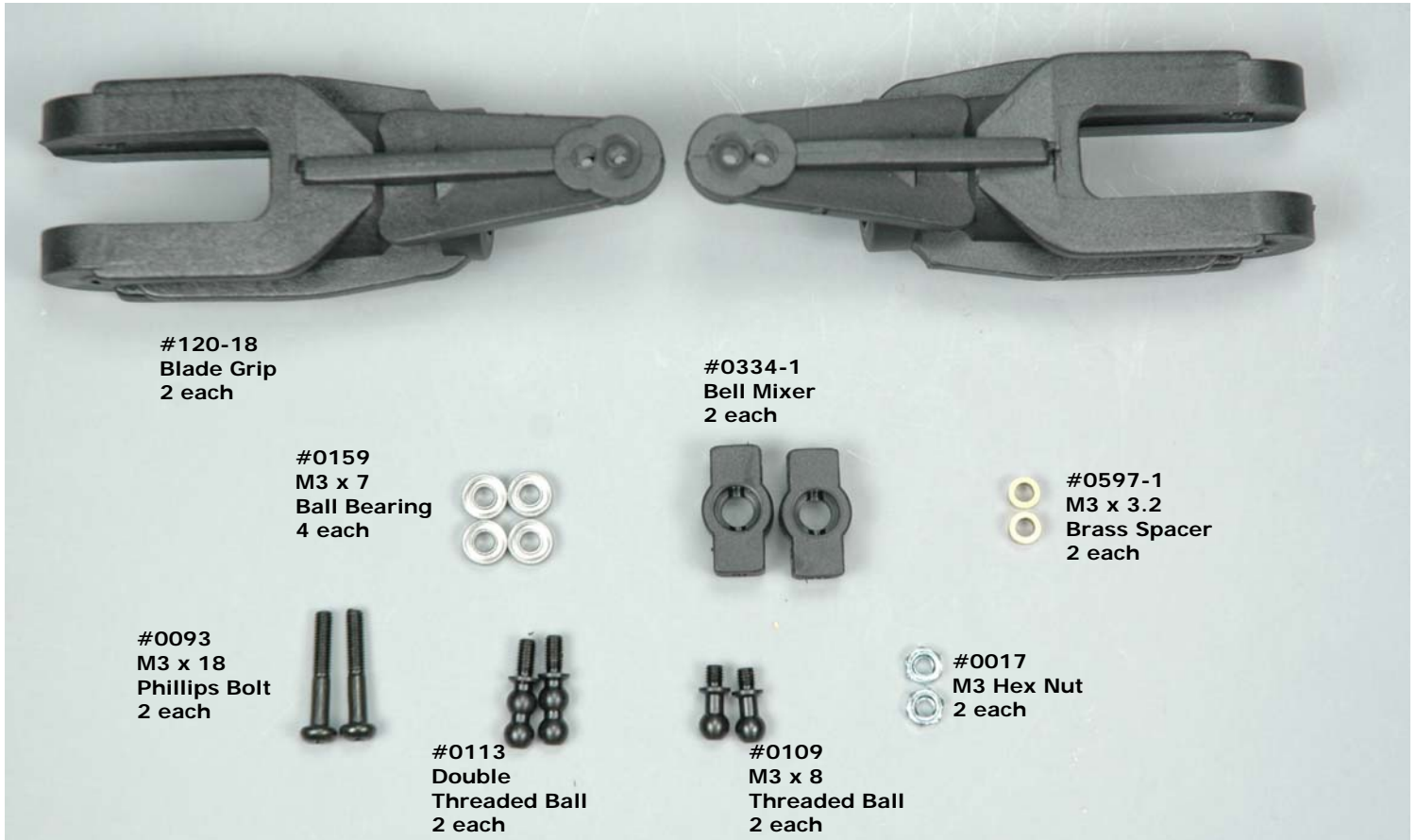

8B.1 – Assemble Bell Mixer

Parts Relationship

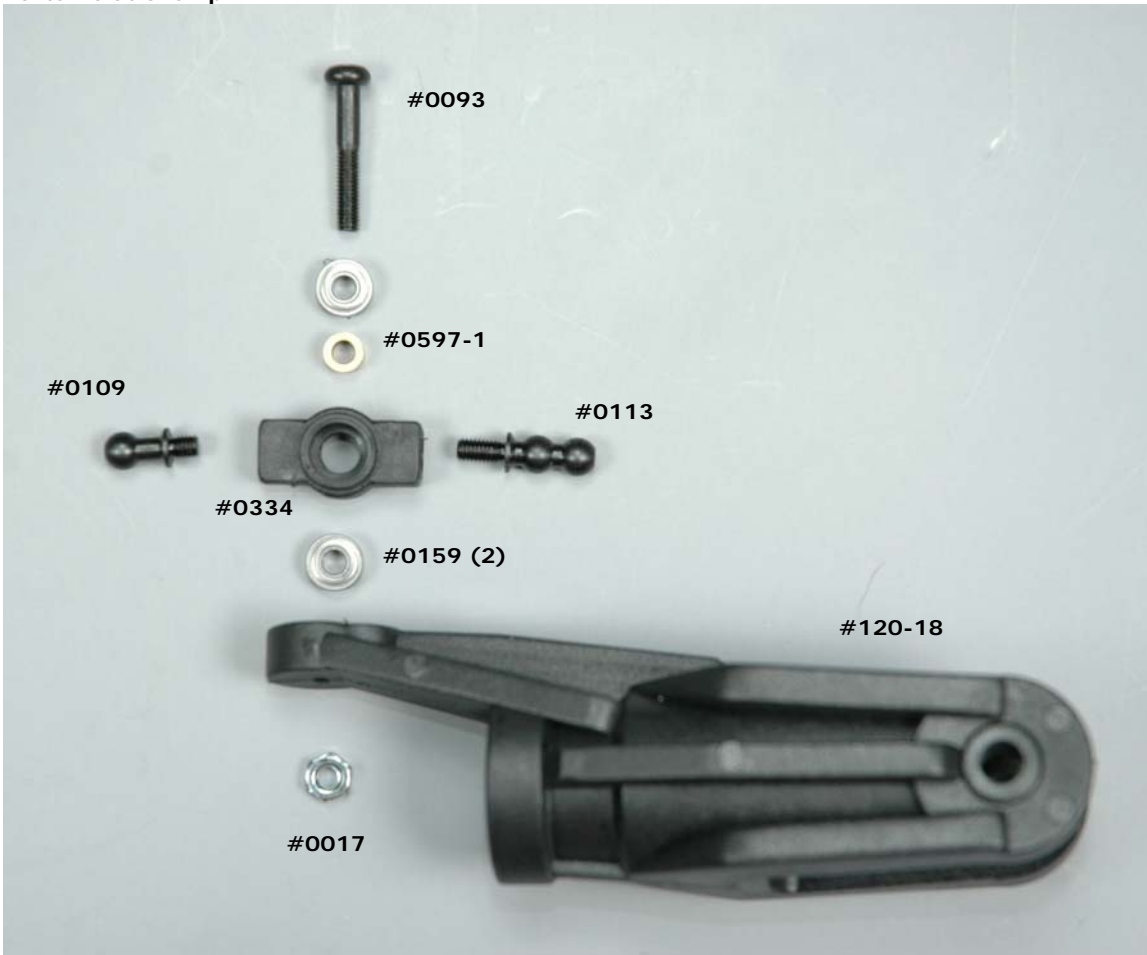

8B.1.a



8B.1.b



8B.1.c



8B.1.d



8B.2 – Install Bell Mixers

8B.2.a

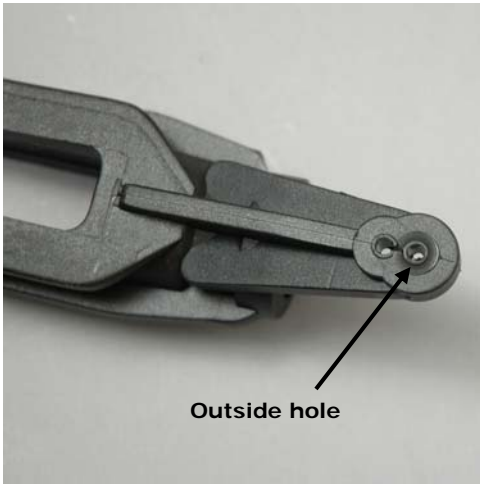

8B.2.b



8B.2.c

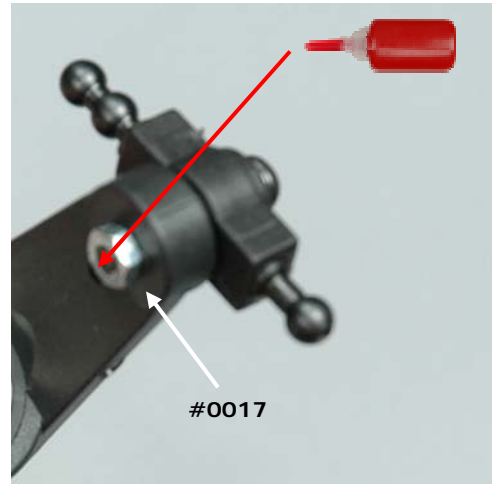

Building Notes - Select the bell mixer with the inserted bolt and thread it into the rear hole on the blade grip tighten it until just before the assembly is fully tight. Check the rotation of the bell mixer. If it does not move freely, slightly loosen the bolt until it does. Attach the M3 hex nut and tighten, making sure that the bell mixer moves freely

Now repeat this procedure for the remaining bell mixer and blade grip.

C) Head Axle Components - Bag #8C

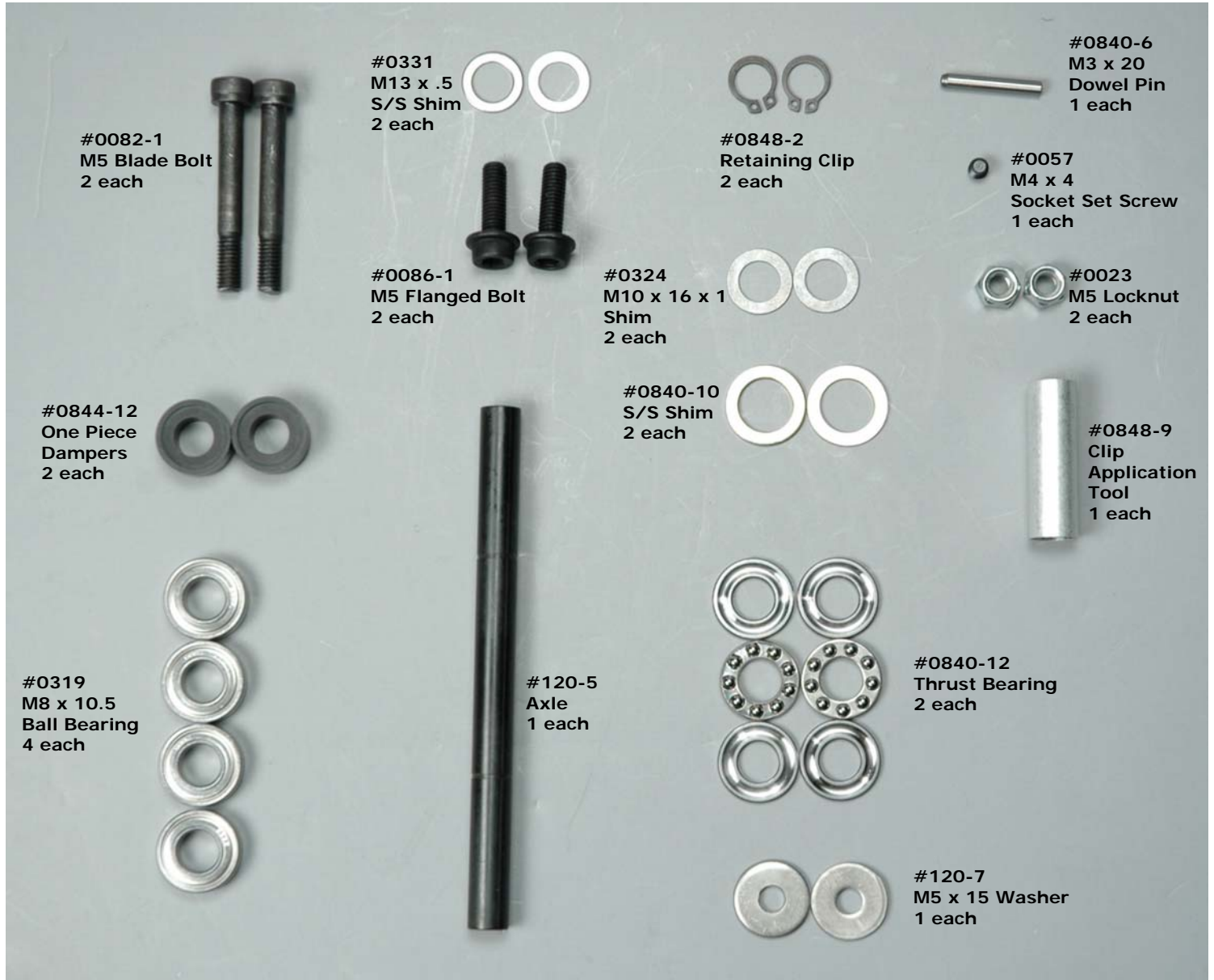

8C.1 - Blade Arm Assembly

Parts Relationship

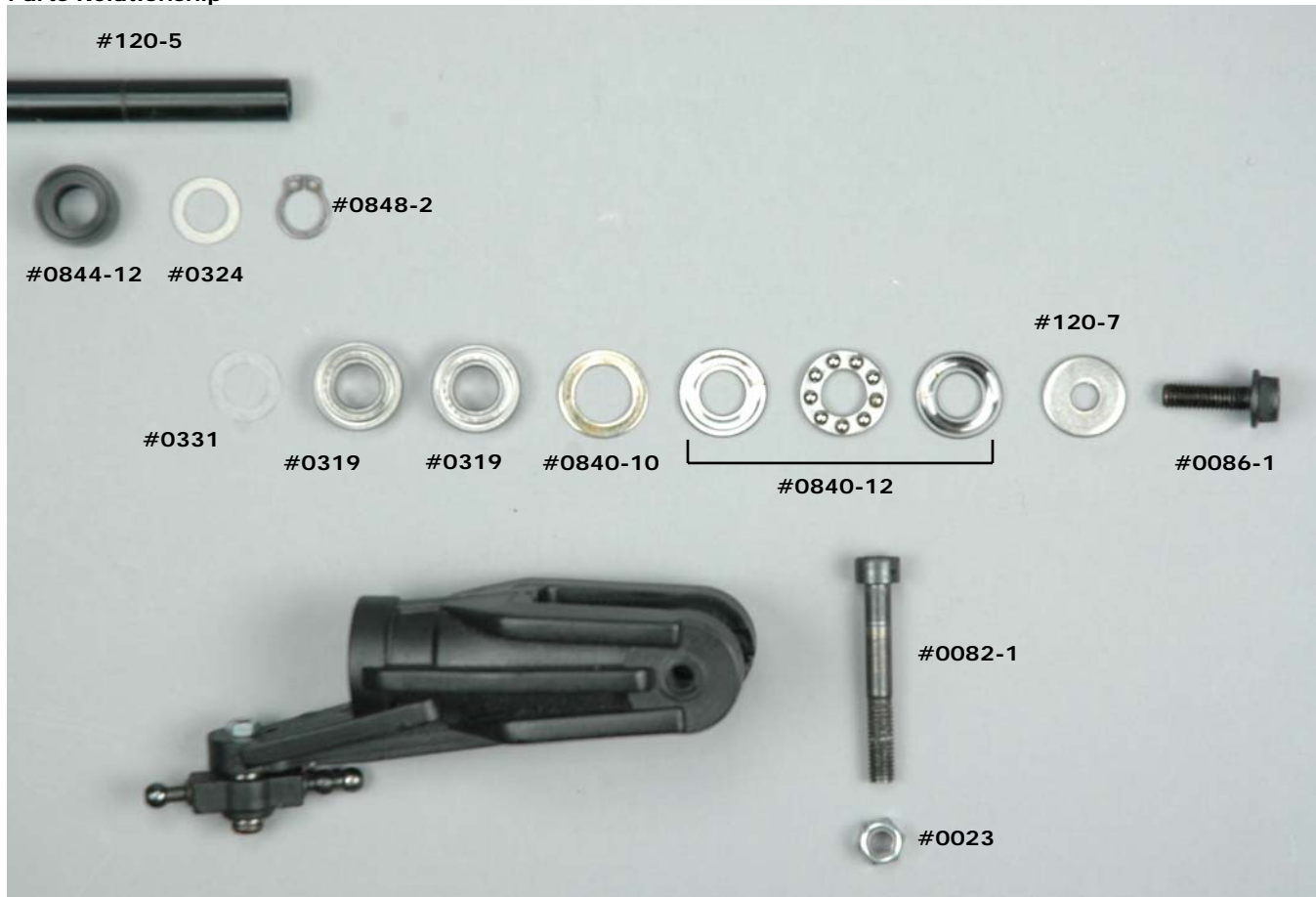

8C.1 – Assemble Blade Arms

8C.1.a



8C.1.b



8C.1.c



XCell Fury Extreme Assembly Manual

8C.1.d

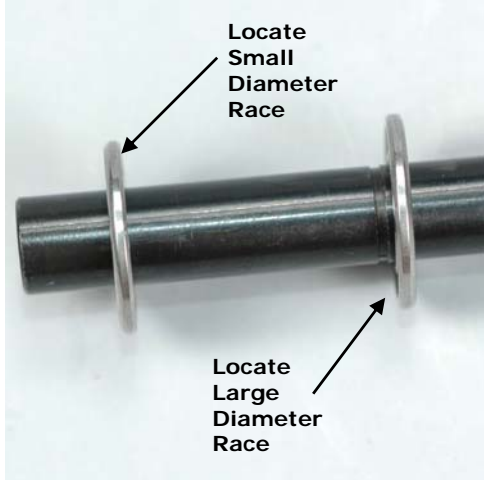

8C.1.e



8C.1.f

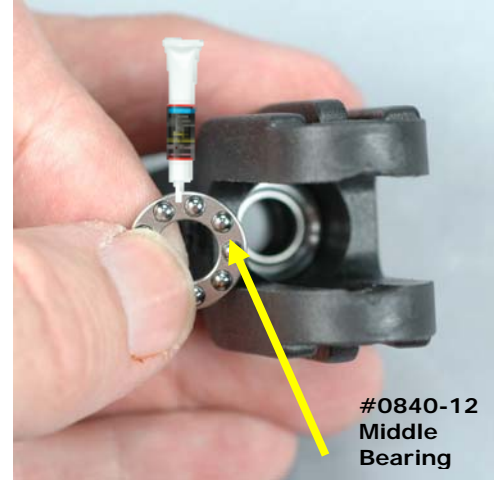

8C.1.g



8C.1.h

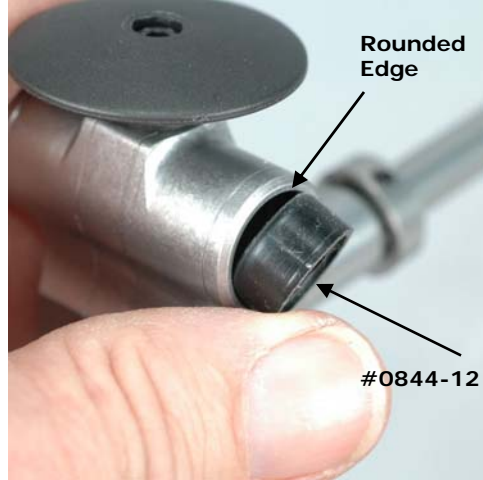

8C.1.i

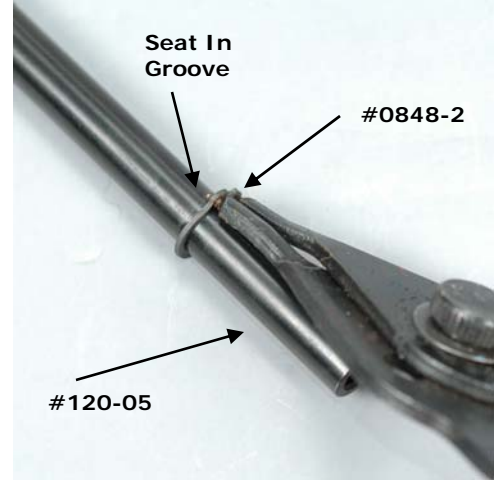

8C.1.j



8C.1.k

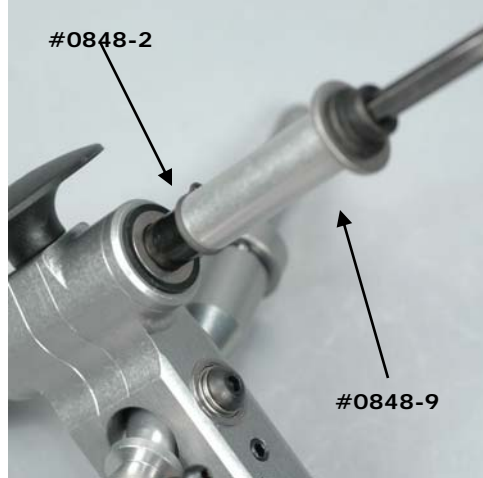

8C.1.l

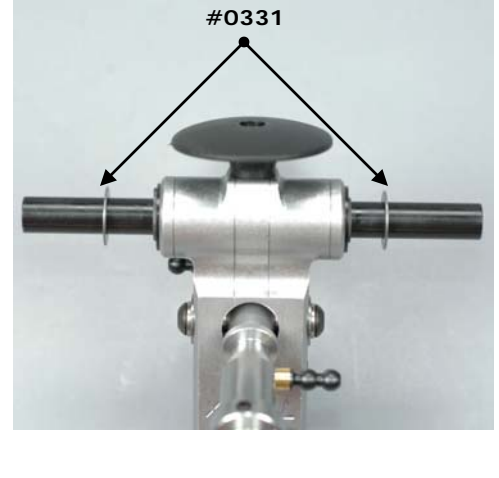

8C.2 – Install Blade Arms

8C.2.a



8C.2.b

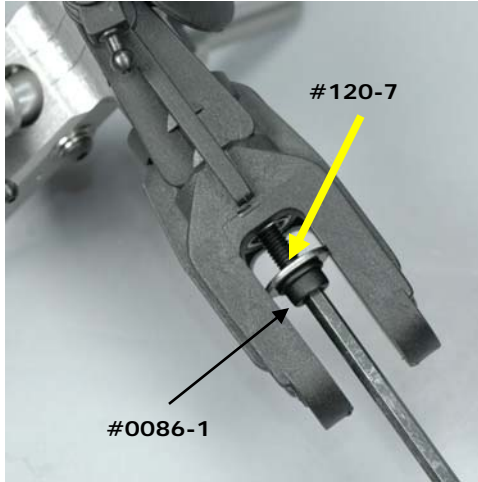

8C.2.c

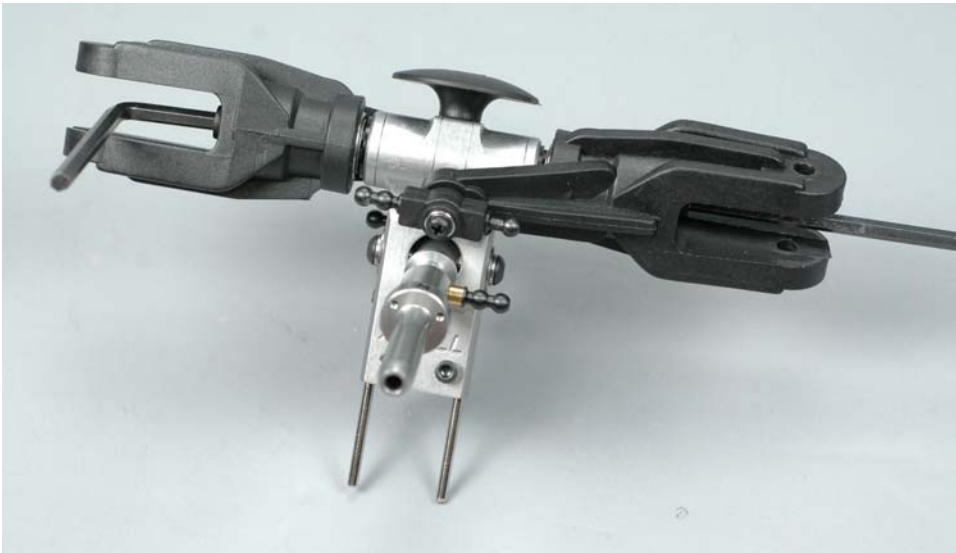

D) Flybar - Bag #8D

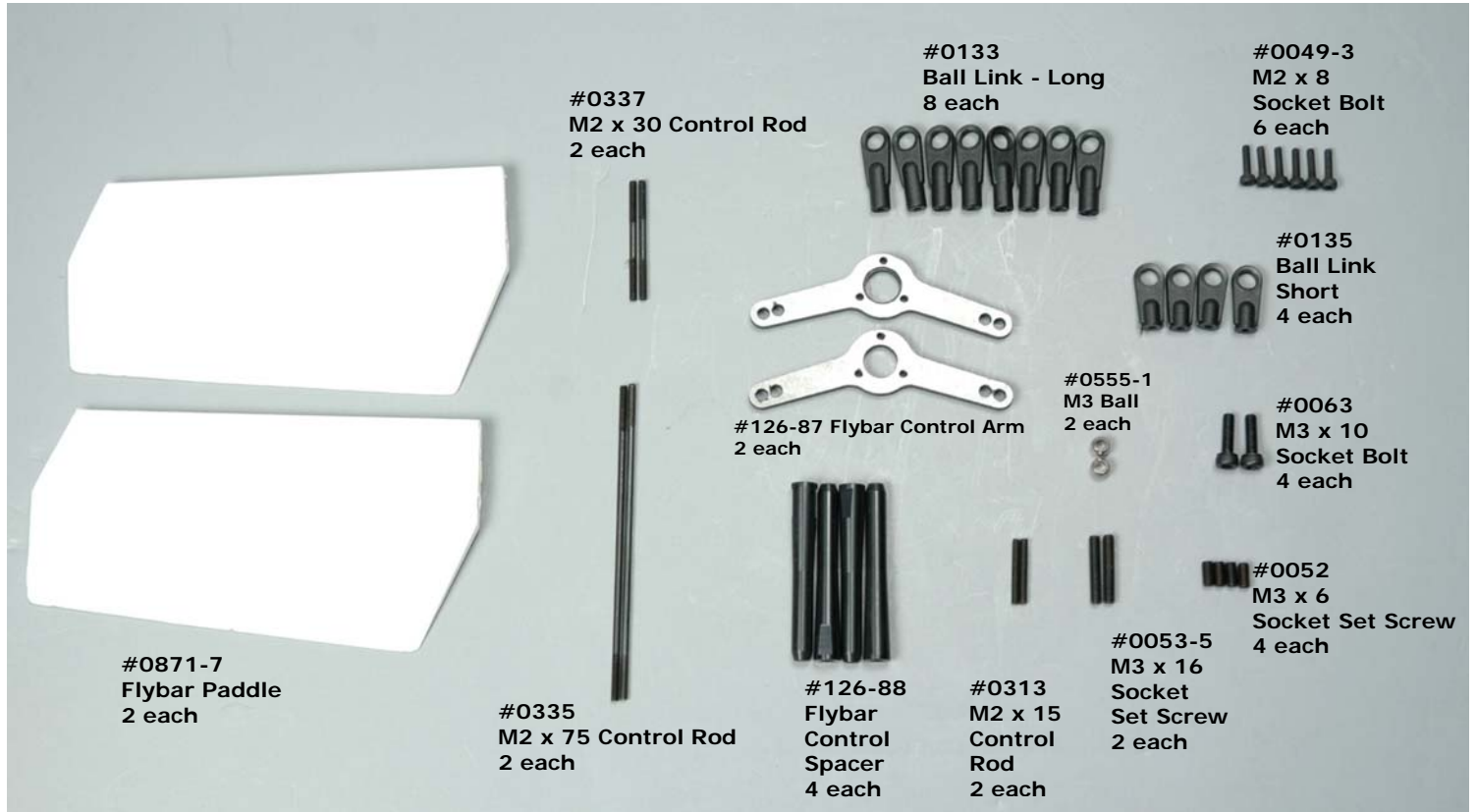

Parts Relationship

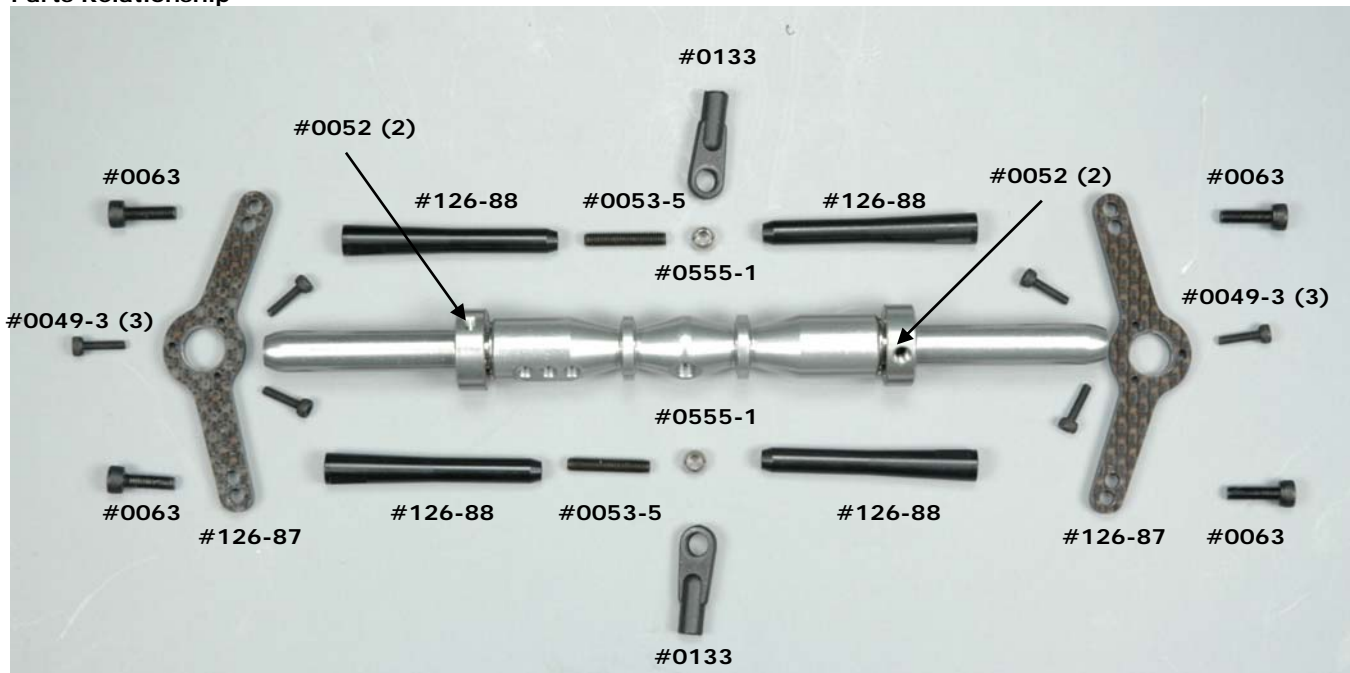

8D.1 – Assemble/Install Flybar Control System

Rod Lengths

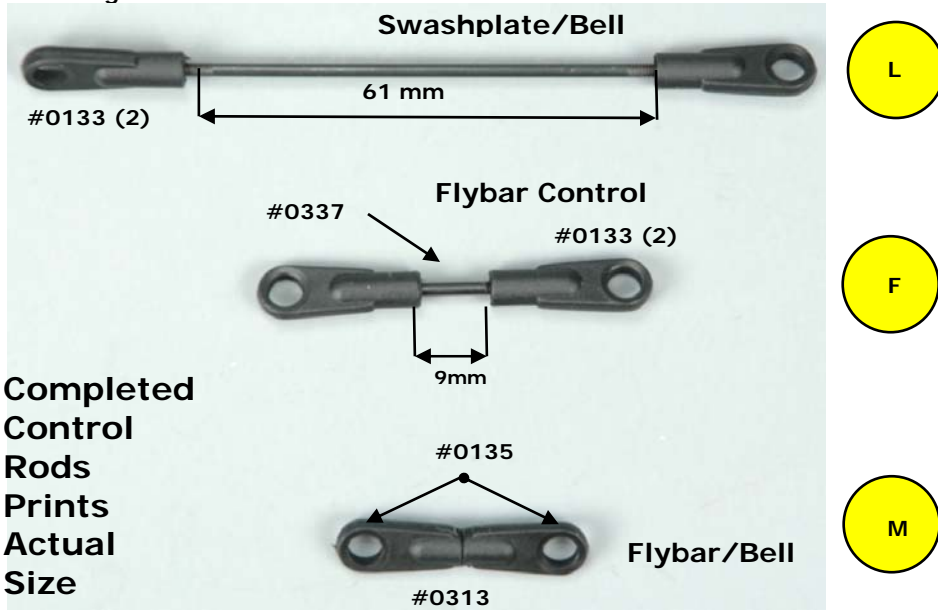

Completed
Control
Rods
Prints
Actual
Size

8D.1.a

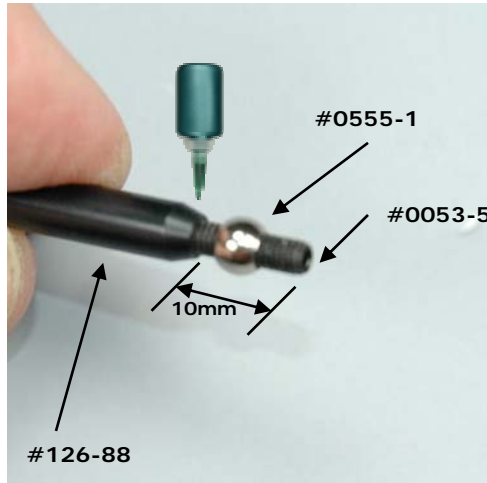

8D.1.b

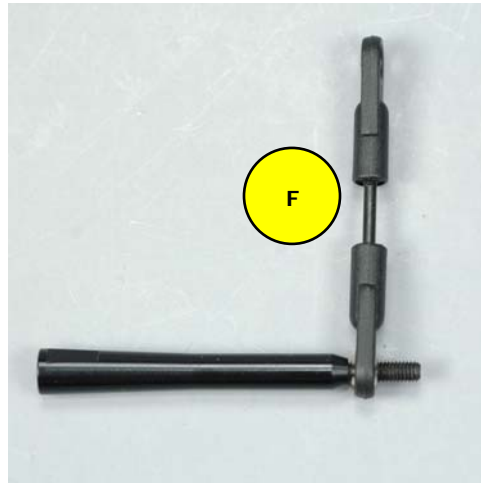

8D.1.c

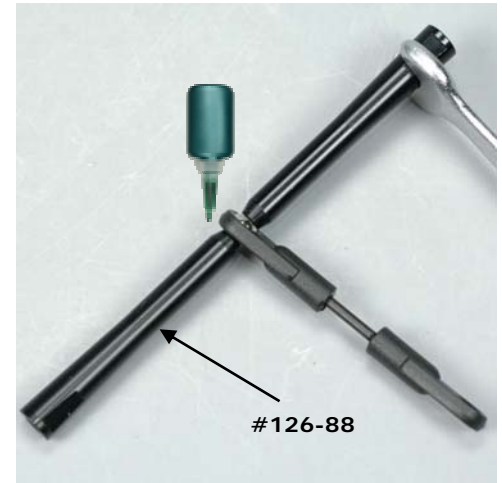

8D.1.d

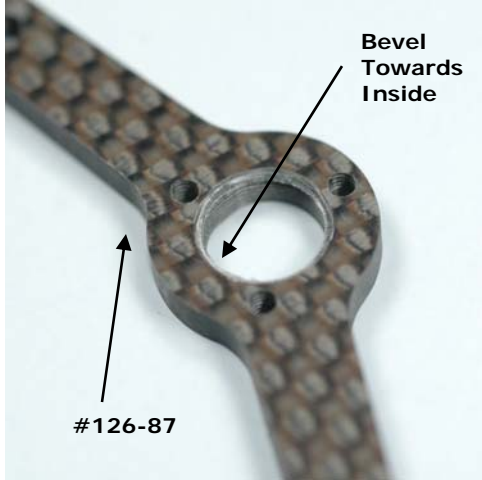

8D.1.e

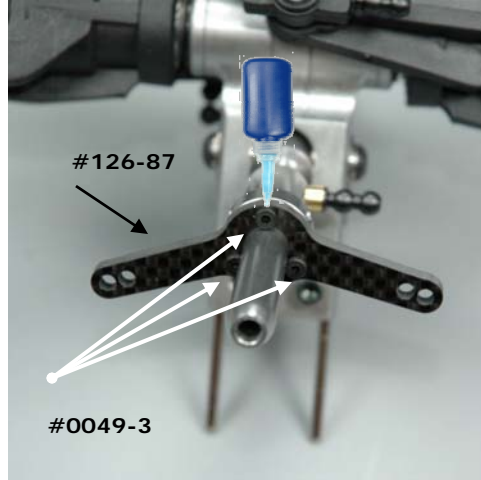

8D.1.f

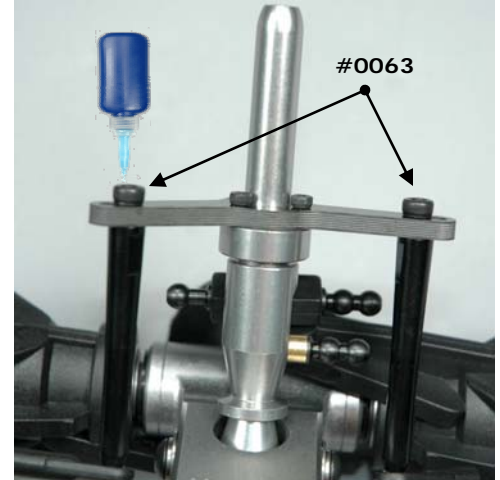

8D.1.g



8D.2 – Assemble/Install Flybar Bell Links

8D.2.a

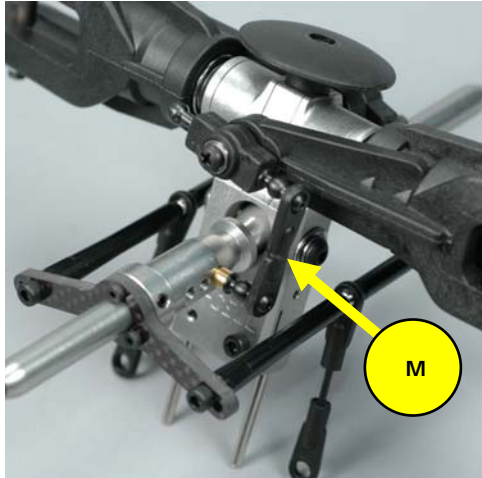

8D.2.b

Building Notes – snap one end of the assembled link onto the double ball on the bell mixer and the other onto the double ball on the flybar carrier. Repeat for the other side

The flybar needed for the next step is located in a separate bag.

8D.3 – Install Flybar

8D.3.a

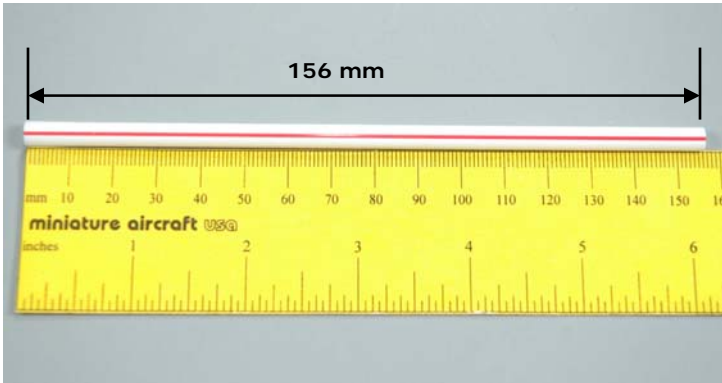

8D.3.b

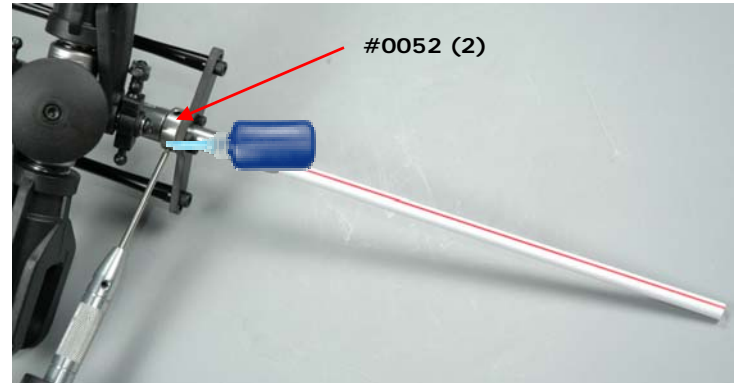

8D.4 – Install Flybar Paddles

8D.4.a

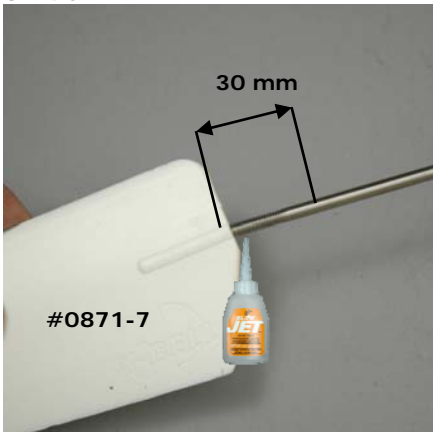

8D.4.b



8D.4.c

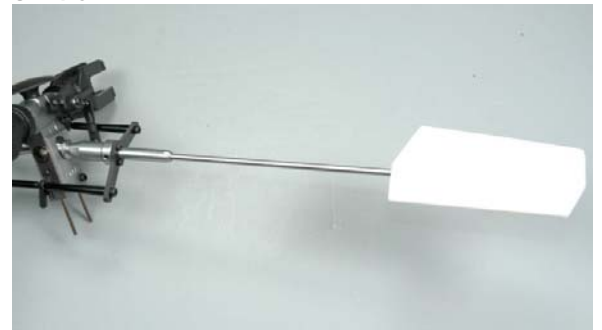

8D.4.d



Building Notes – make sure both flybar paddles are parallel to each other and the flybar control arms

8D.5 – Install Rotor Head

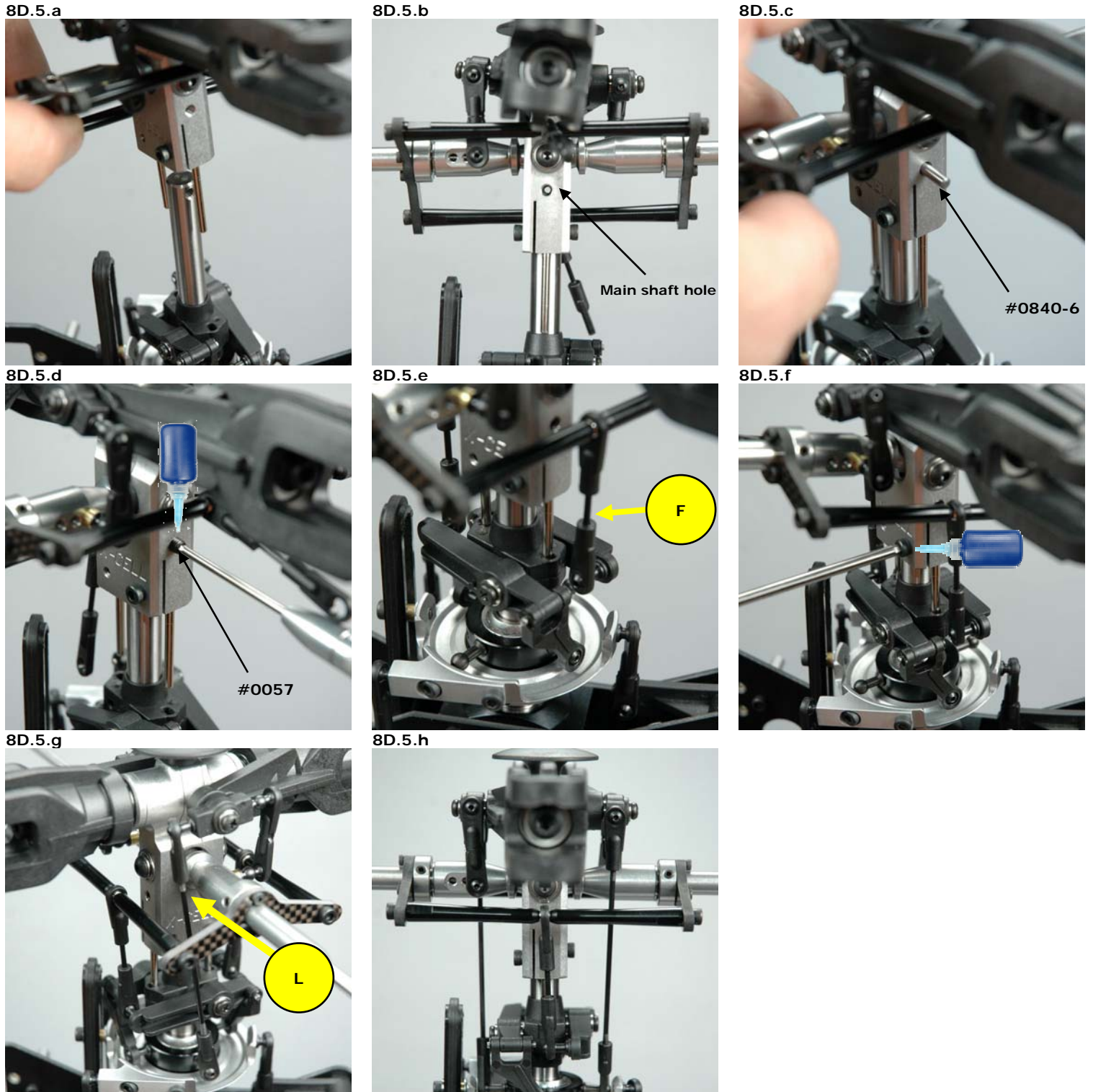

Step #9 – Tail Rotor Assembly

A) Tail Rotor Hub - Bag #9A

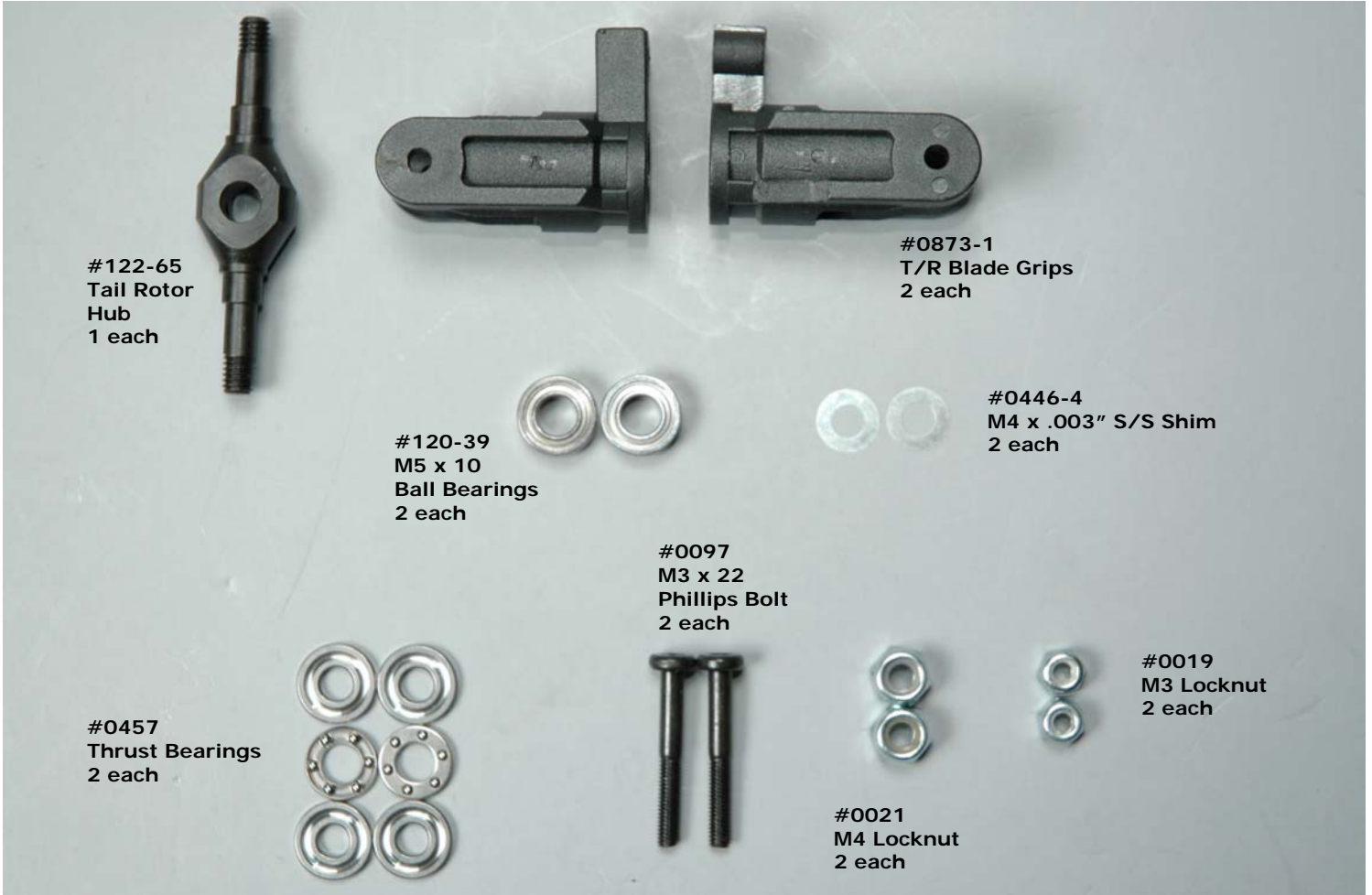

9A.1 – Assemble Tail Rotor Hub

Parts Relationship

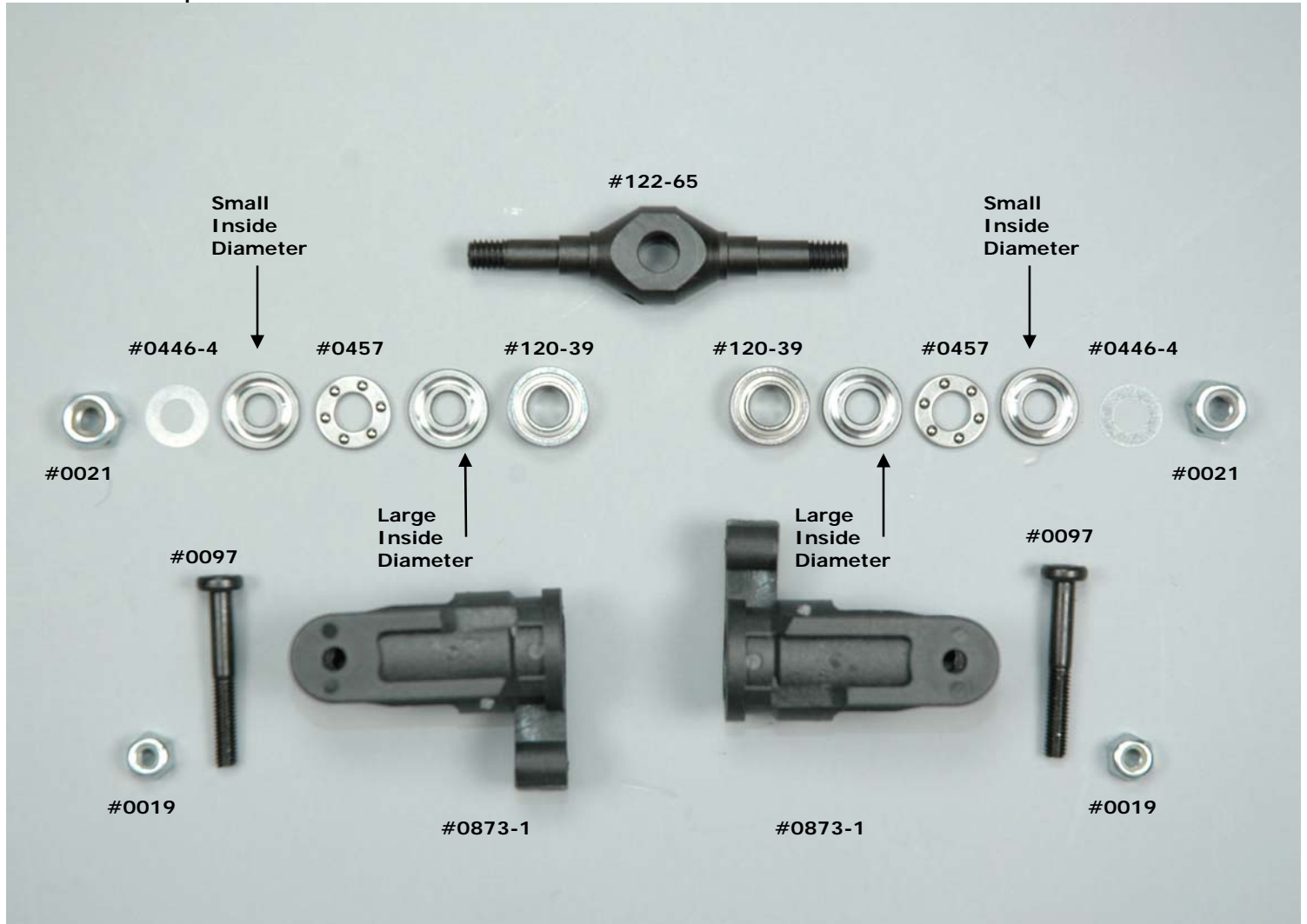

9A.1.a

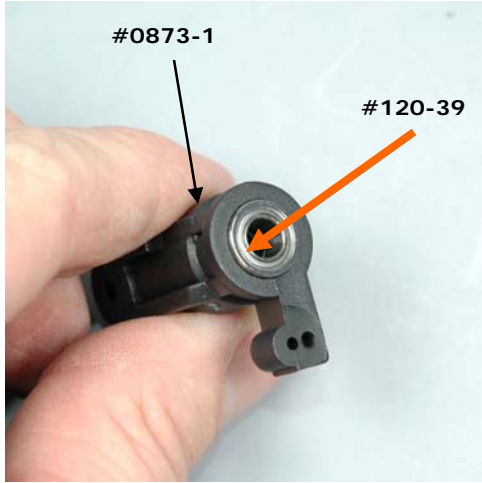

9A.1.b

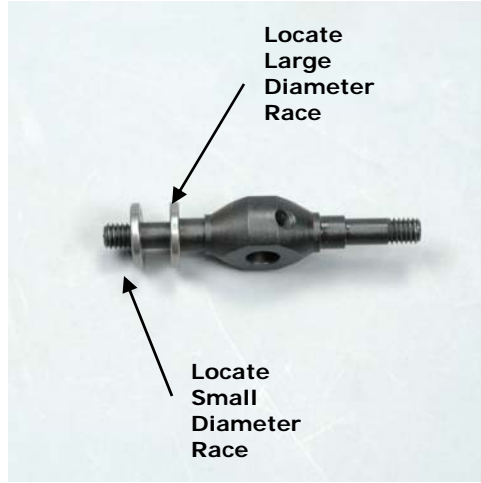

9A.1.c

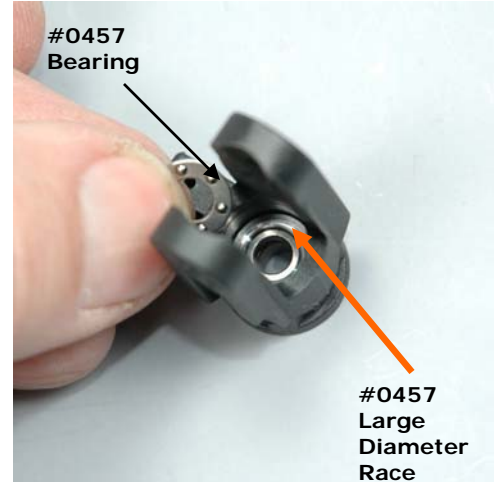

9A.1.d



9A.1.e



9A.1.f



9A.1.g



9A.1.h



9A.1.i



XCell Fury Extreme Assembly Manual

9A.2 – Install Tail Rotor Blades

9A.2.a



9A.2.b



9A.2.c

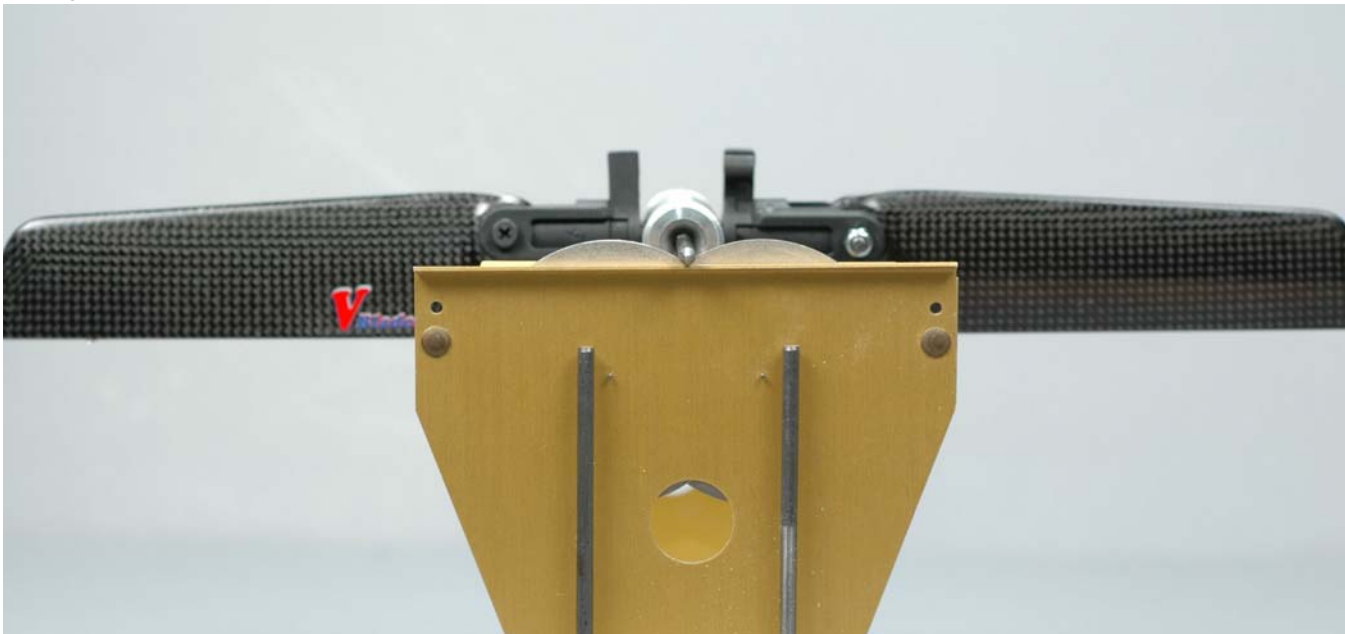

B) Tail Rotor Pitch Yoke - Bag #9B



9B.1 – Assemble TR Pitch Yoke

Parts Relationship



XCell Fury Extreme Assembly Manual

9B.1.a



9B.1.b



9B.1.c



9B.1.d



9B.1.e



9B.1.f



9B.1.g



9B.1.h

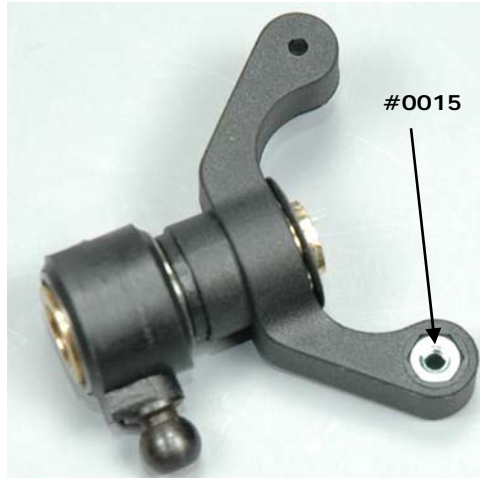

C) Tail Rotor Transmission - Bag #9C

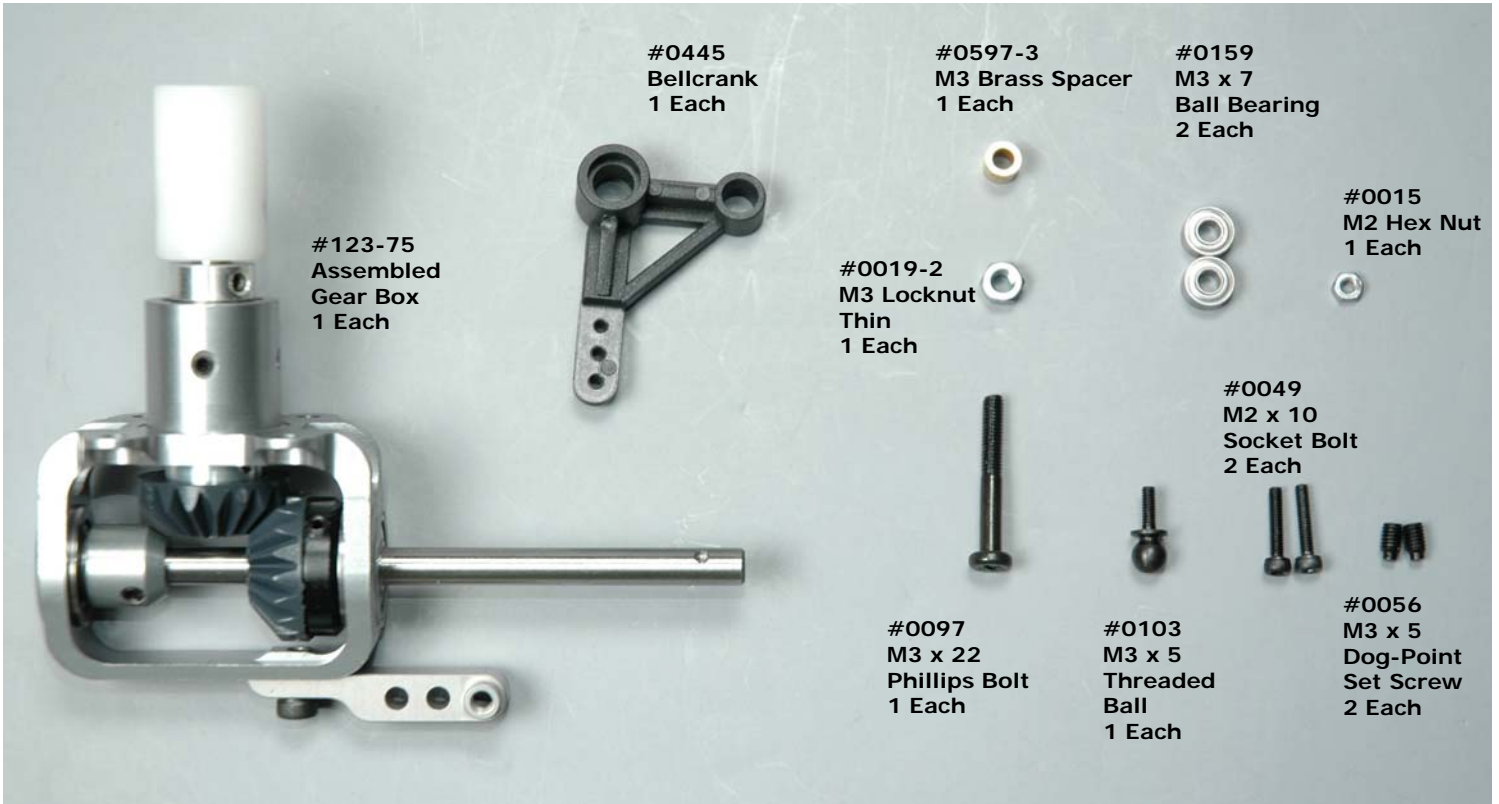

9C.1 – Assemble T/R BellCrank

Parts Relationship



XCell Fury Extreme Assembly Manual

9C.1.a

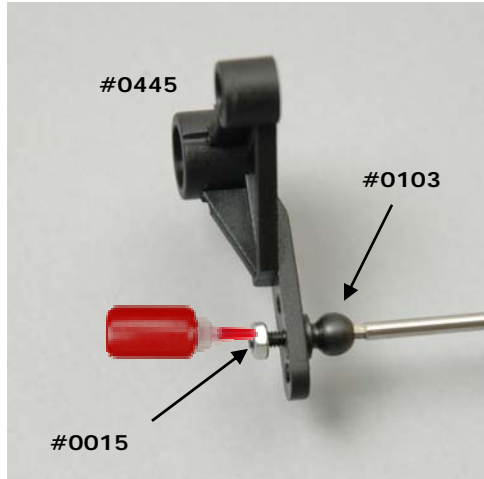

9C.1.b



9C.1.c



9C.1.d

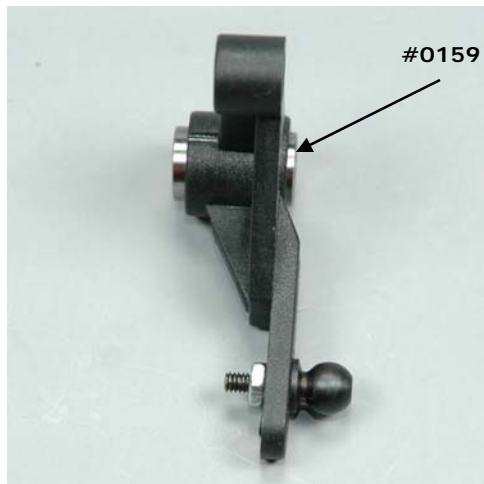

9C.2 – Install T/R BellCrank

9C.2.a



9C.2.b



9C.3 – Install T/R Pitch Yoke

9C.3.a



9C.3.b



9C.3.c

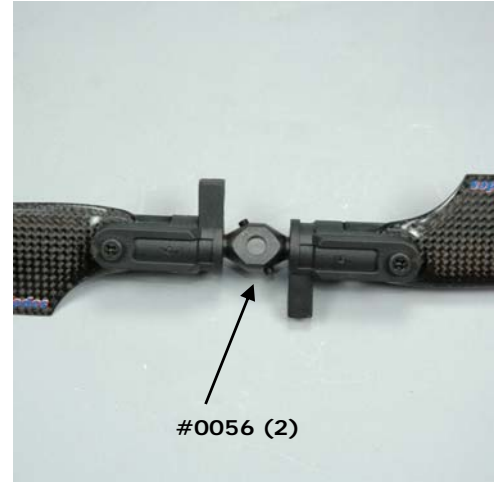

Step #10 – Locate Tail Boom Components

A) Tail Boom Components - Bag #10



Building Notes – Locate Bag 10.

These parts are to be used in other steps. They are bagged together due to their size and to ensure that they are not damaged.

Step #11 – Tail Boom Assembly

A) Tail Boom Mounts - Bag #11A

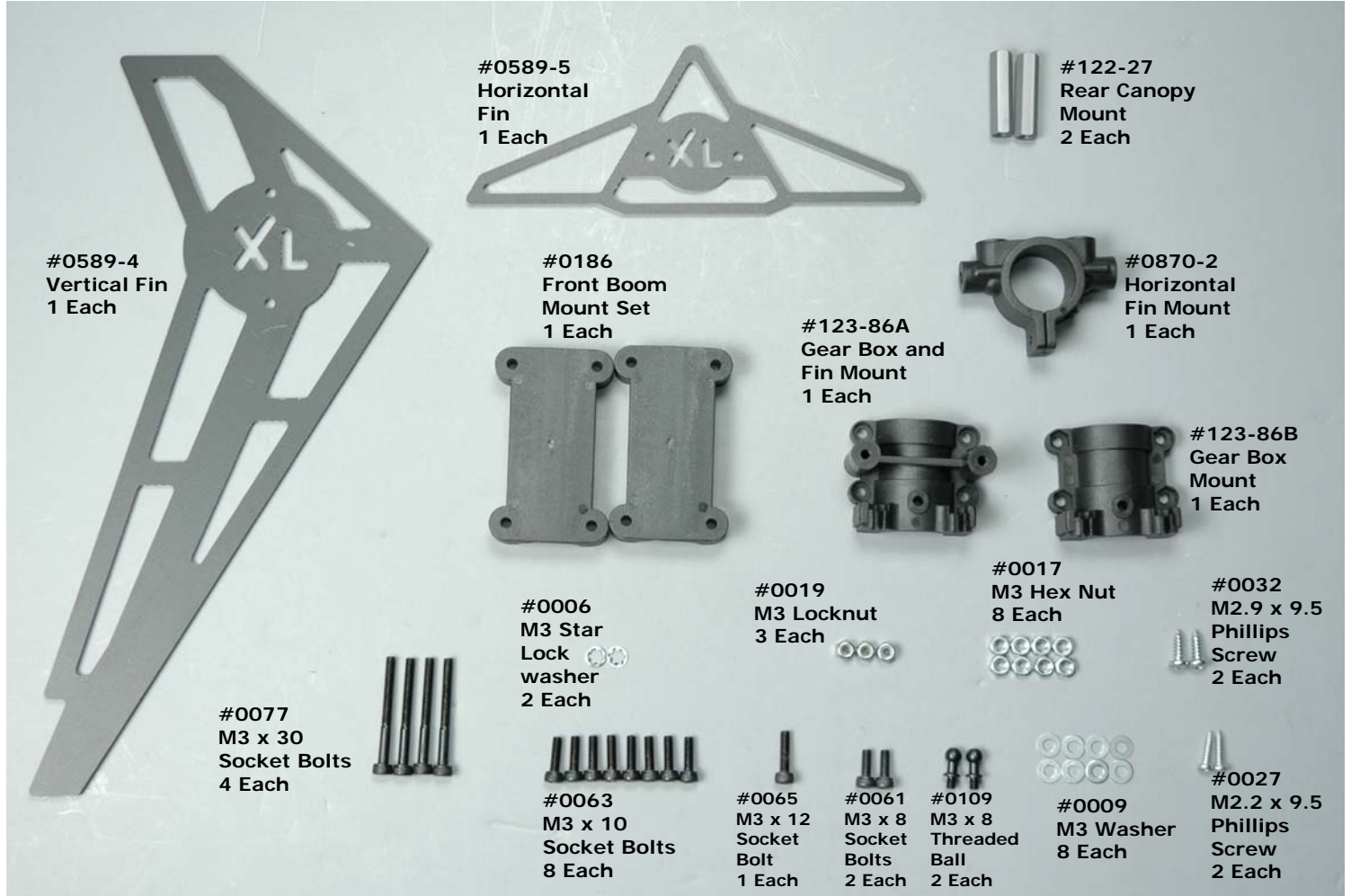

1A.1 – Install Tube Drive

11A.1.a



Building Notes – before inserting the tube drive into the tail boom as shown, spray inside the boom with a spray glass cleaner (like Windex®). This will make the tube drive easier to insert

11A.2 – Install T/R Transmission

11A.2.a



11A.2.b



11A.3 – Install Vertical Fin Mount/Fin

Parts Relationship

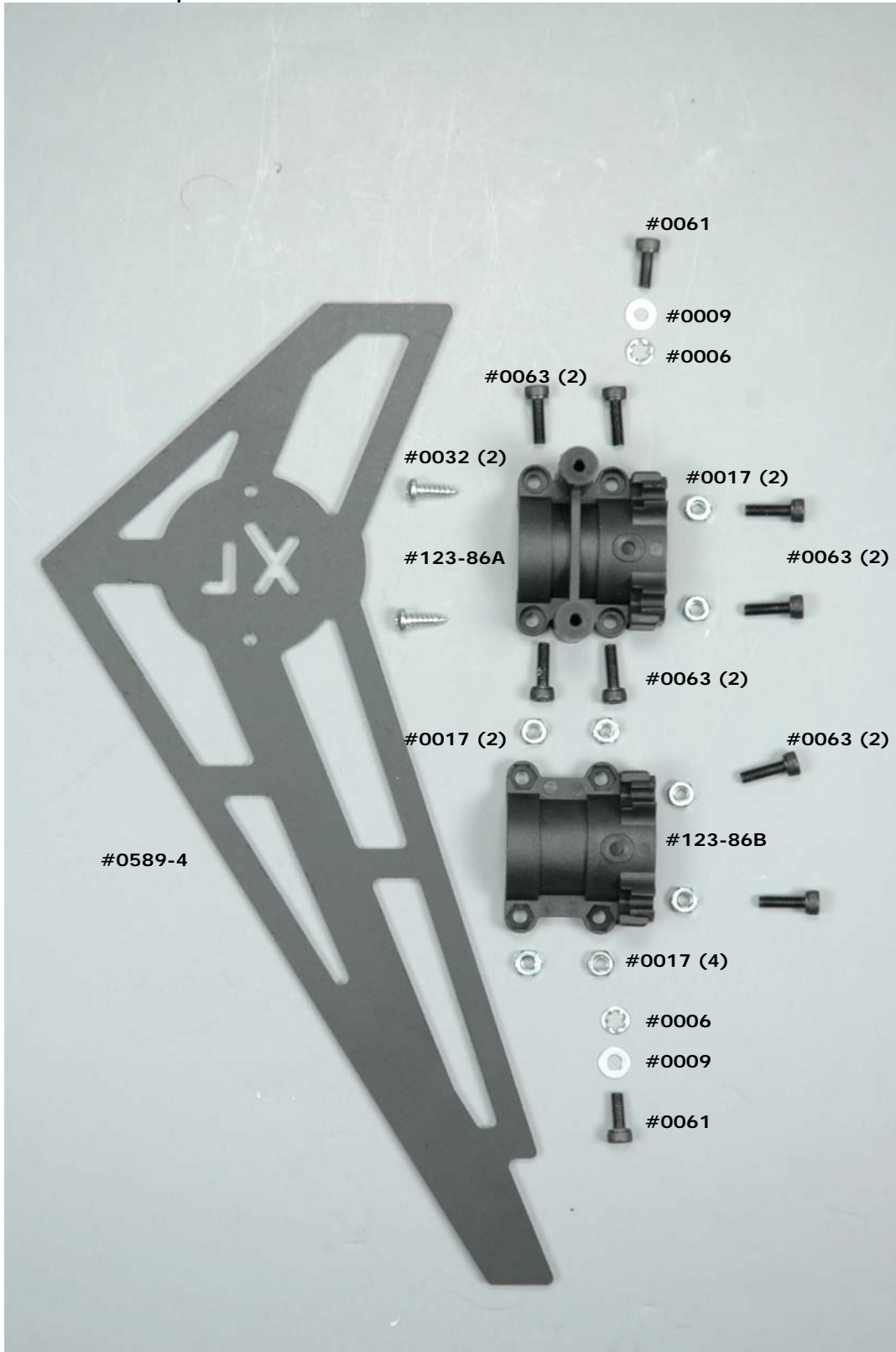

11A.3.a

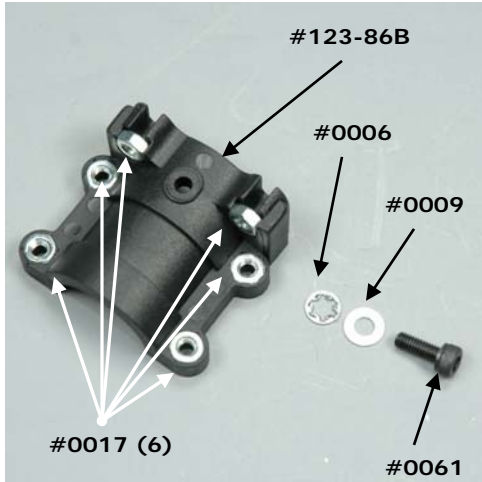

11A.3.b



11A.3.c

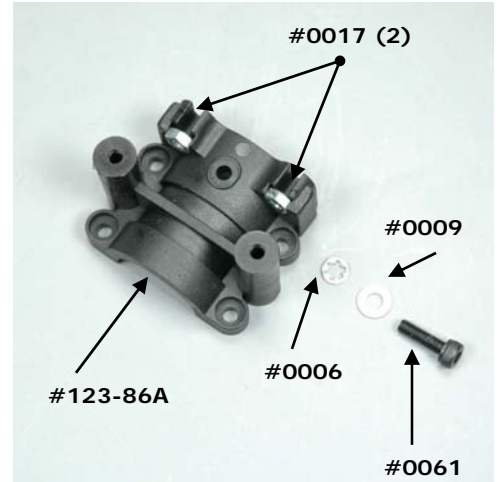

11A.3.d



11A.3.e

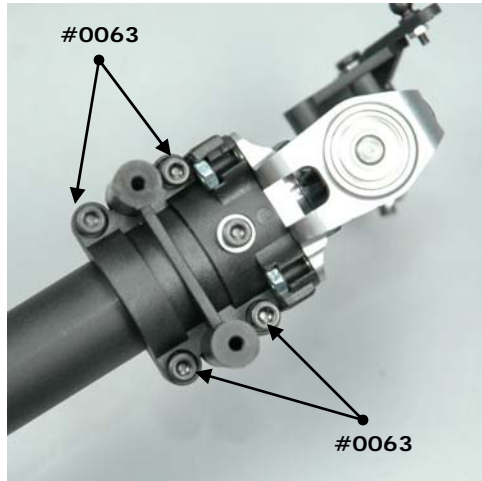

11A.3.f



11A.3.g

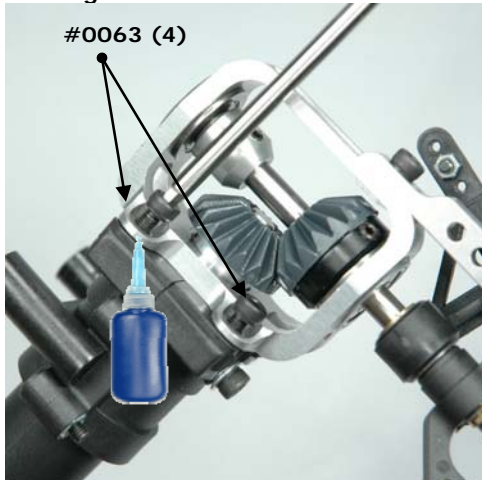

11A.3.h

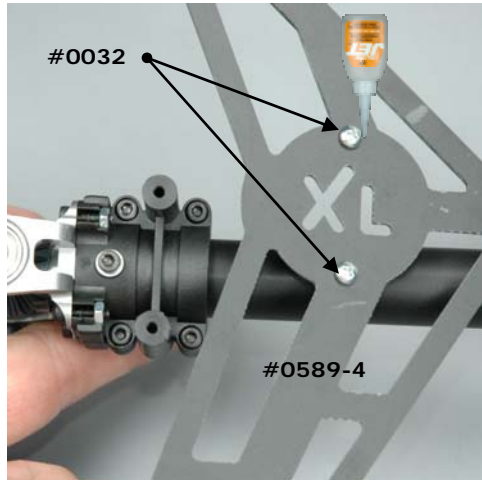

Building Notes – do not overtighten any bolts in this assembly

11A.4 – Install Horizontal Fin Mount/Fin

Parts Relationship

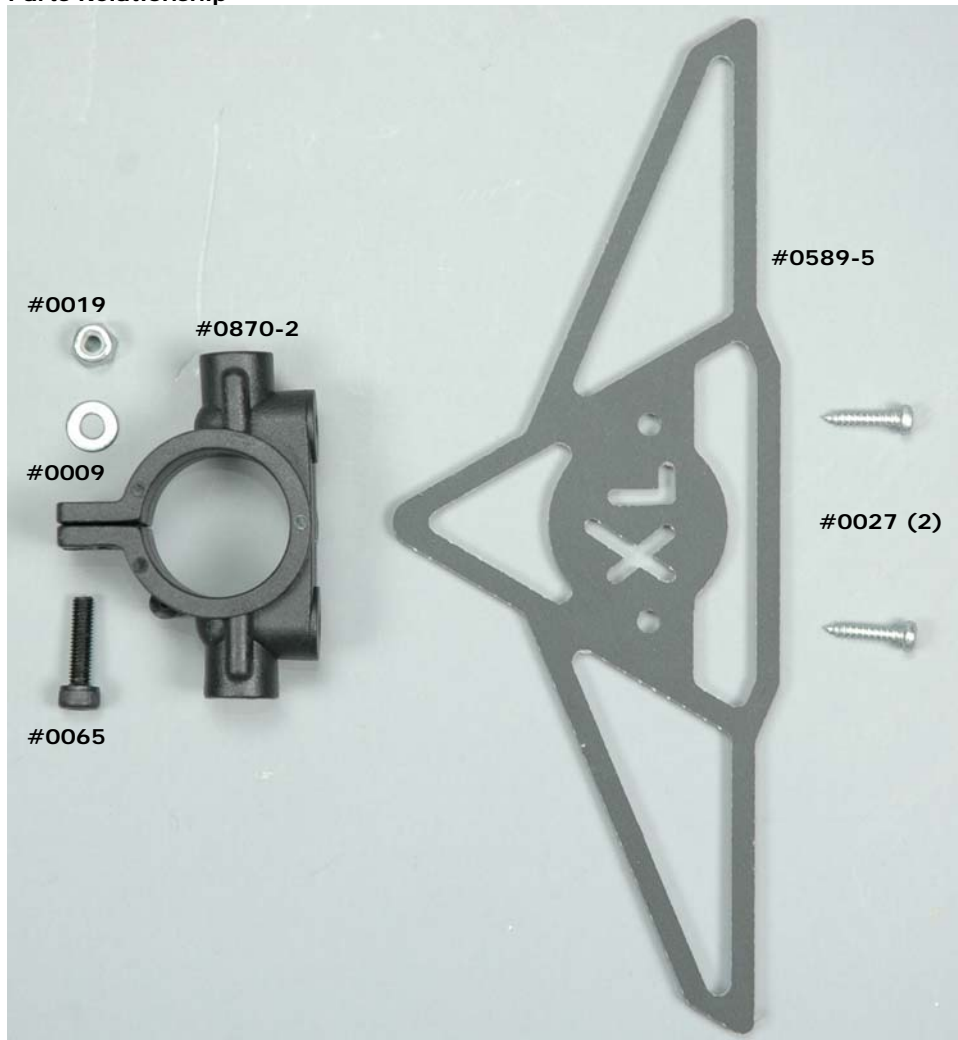

XCell Fury Extreme Assembly Manual

11A.4.a



11A.4.b

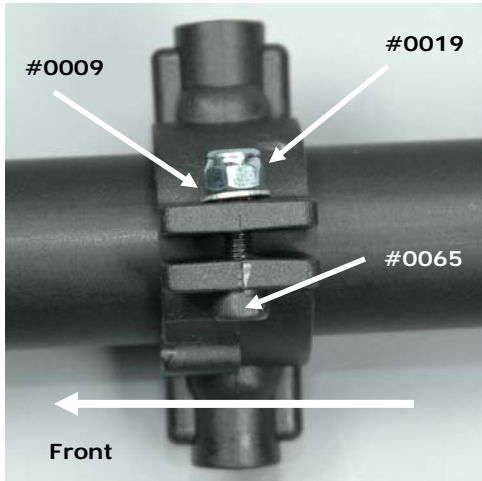

11A.4.c

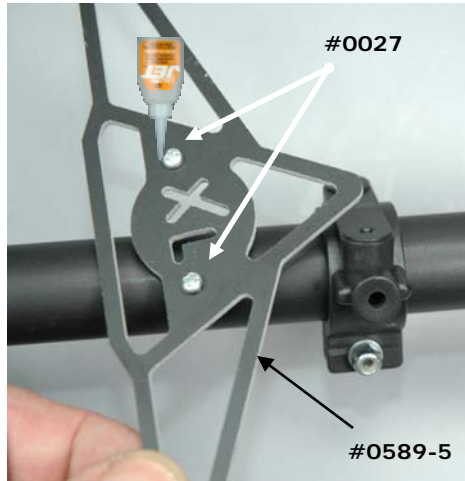

11A.4.d



11A.5 – Install Tail Rotor

11A.5.a



11A.5.b



11A.5.c

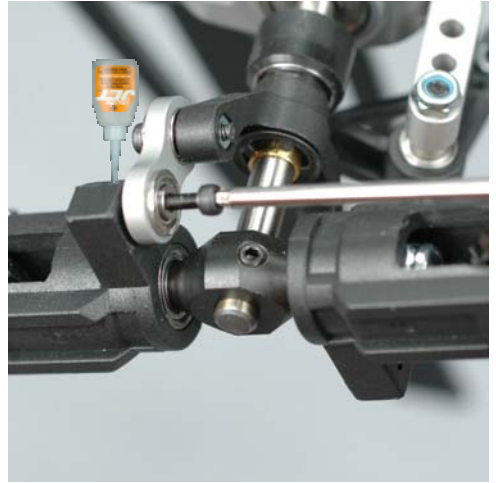

11A.6 – Install Front Tail Boom Mount

Parts Relationship

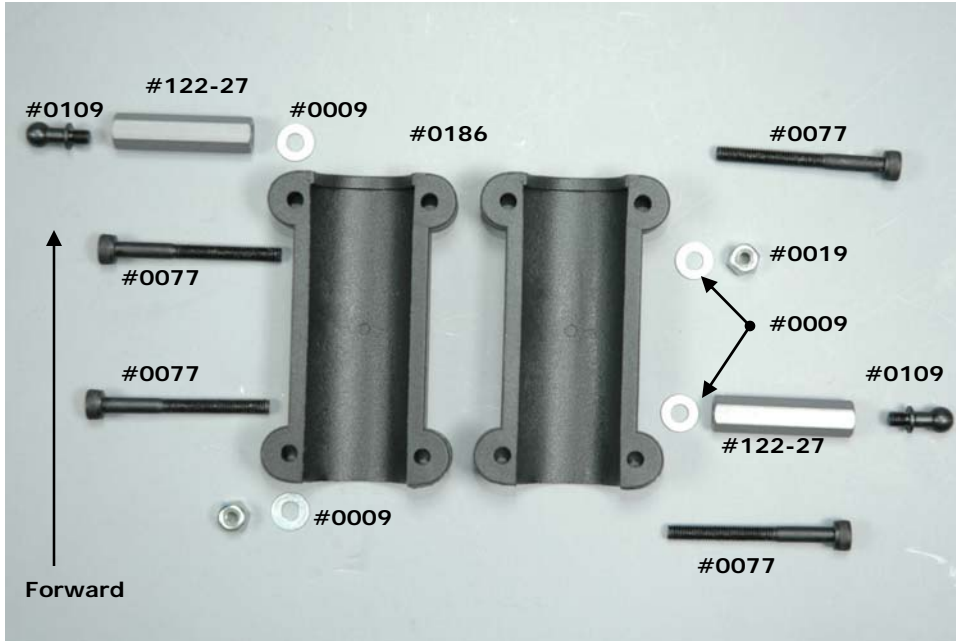

11A.6.a

11A.6.b

11A.6.c

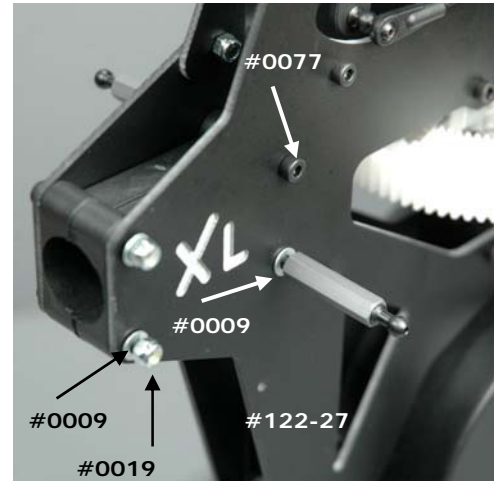
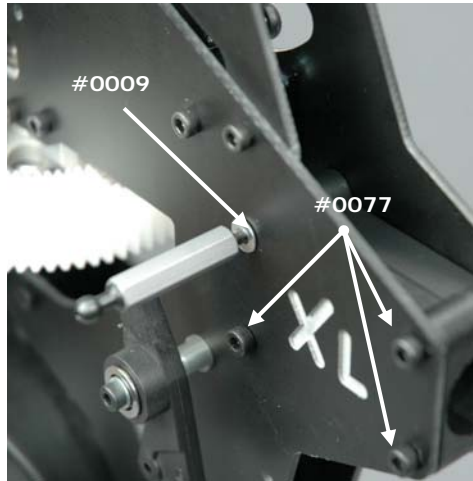
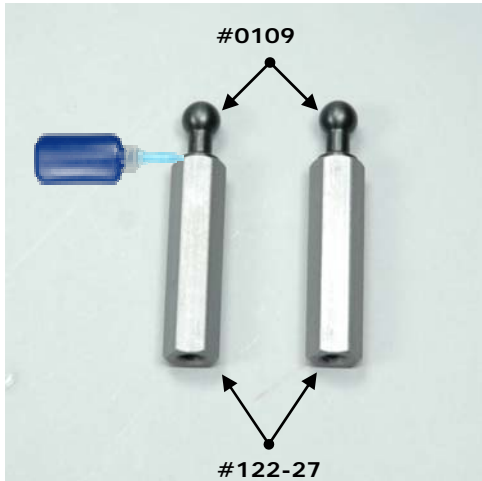

B) Tail Rotor Pushrod Components - Bag #11B

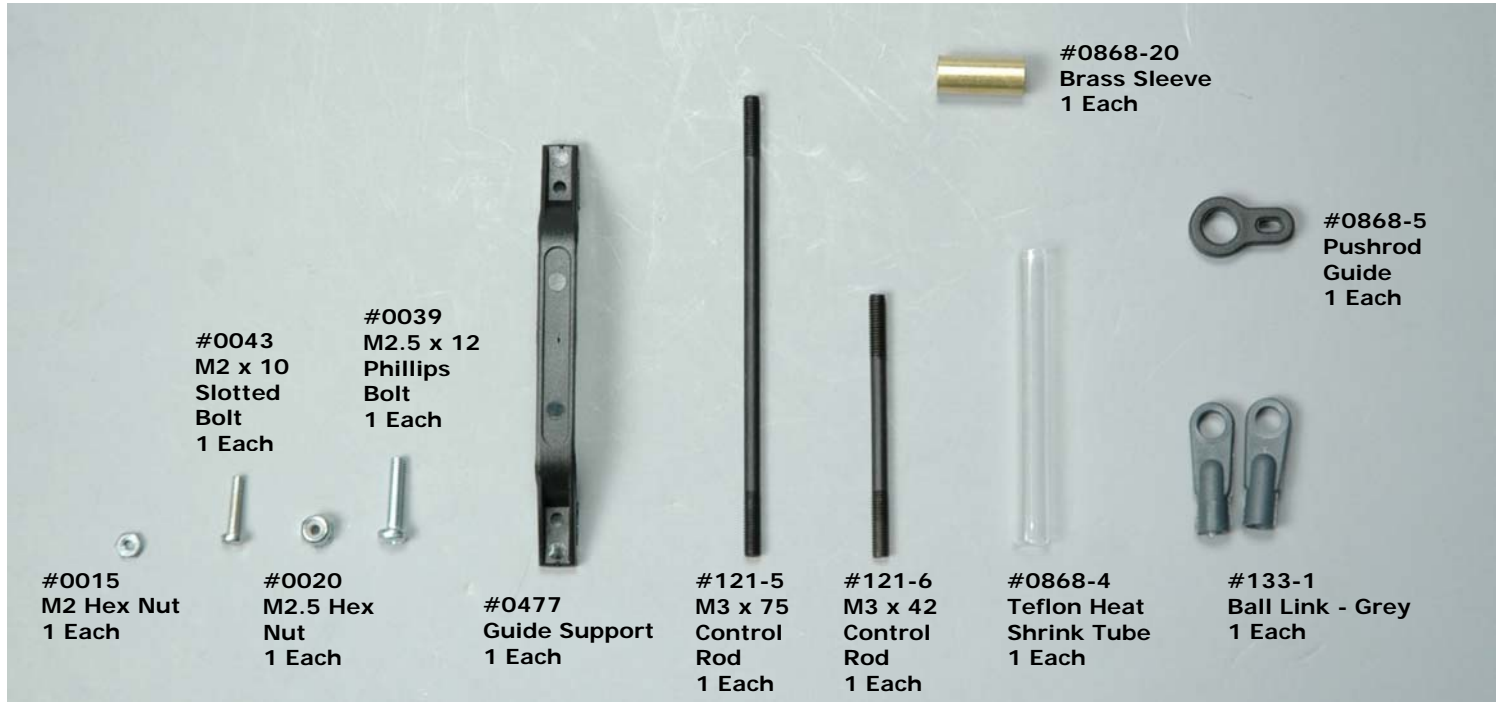

Parts Relationship

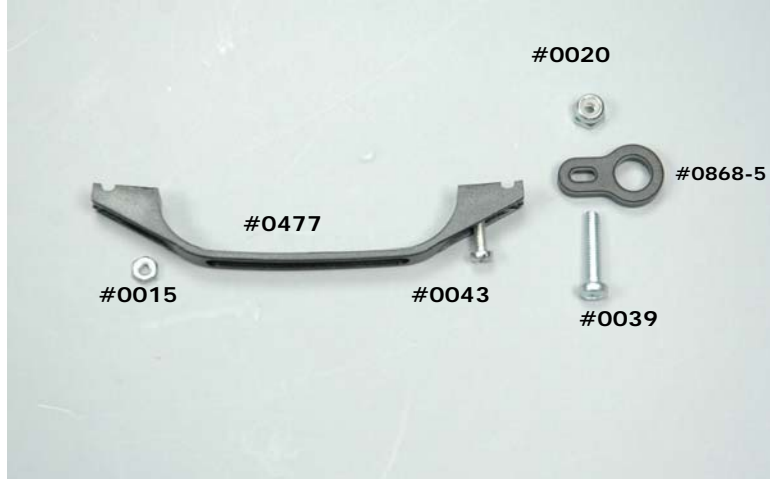

11B.1 – Assemble/Install T/R Pushrod Guide

11B.1.a

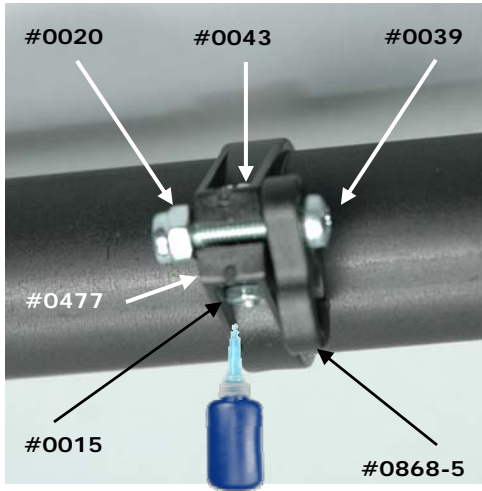

11B.1.b

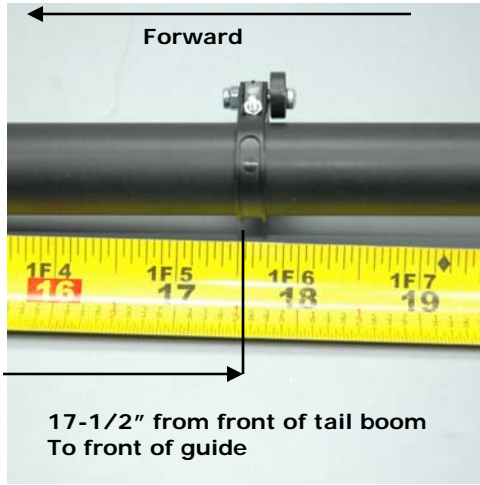

11B.2 – Install Tailboom

11B.1.a



11B.1.b

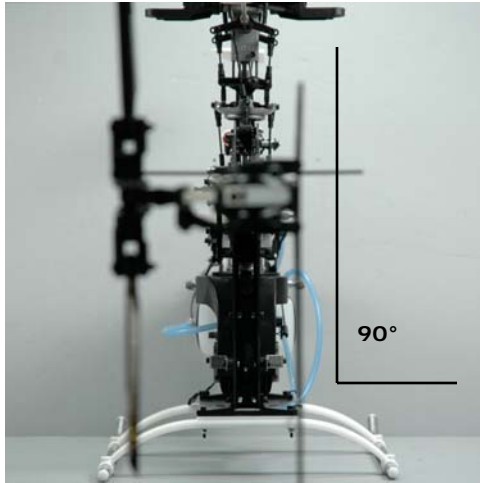

11B.1.c



11B.3 – Assemble T/R Pushrod

11B.3.a

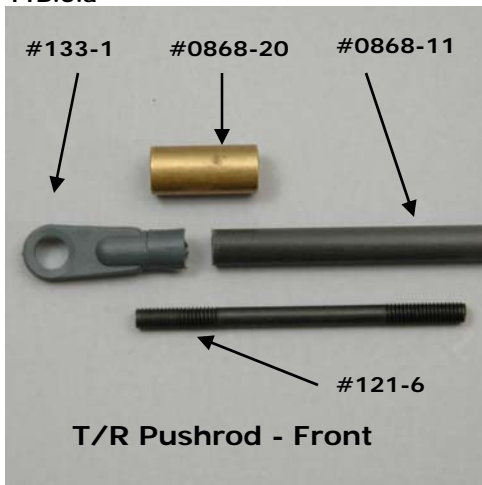

11B.3.b

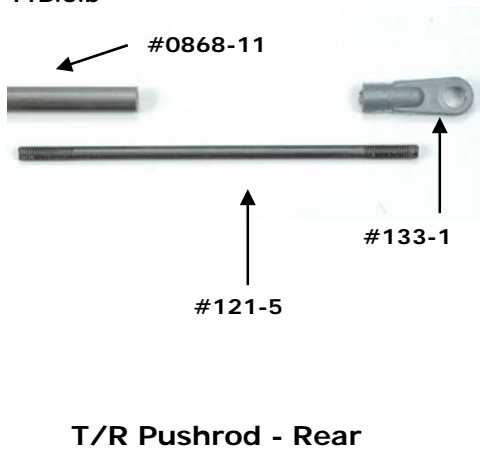

11B.3.c



11B.3.d



11B.3.e



11B.3.f

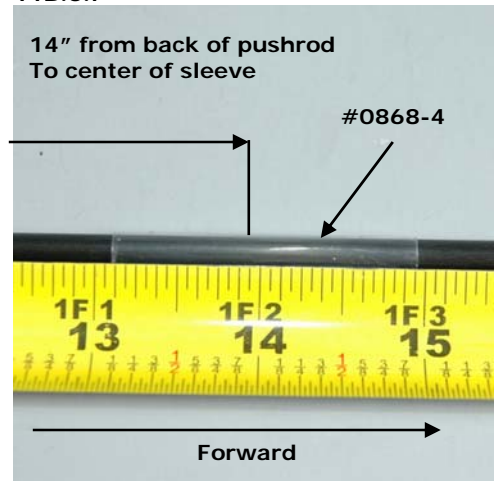

11B.3.g



11B.3.h

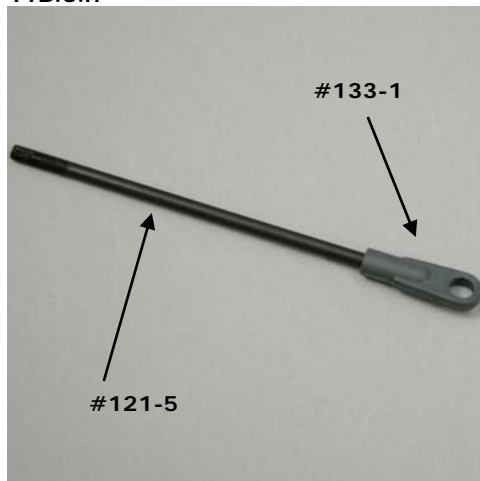

11B.3.i

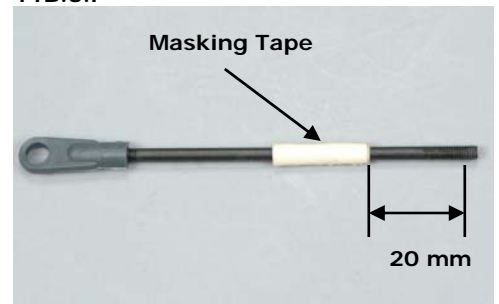

XCell Fury Extreme Assembly Manual

11B.3.j



Building Notes – test assemble all of these components before applying adhesive

11B.4 – Install T/R Pushrod

11B.4.a



11B.4.b



11B.4.c



C) Tail Boom Support Components - Bag #11C



11C.1 – Assemble Tail Boom Supports

Parts Relationship



Parts Relationship

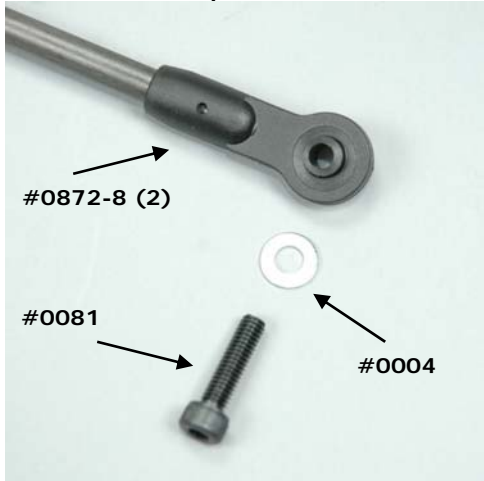

11C.1.a



11C.1.b



11C.2 – Install Tail Boom Supports

11C.2.a

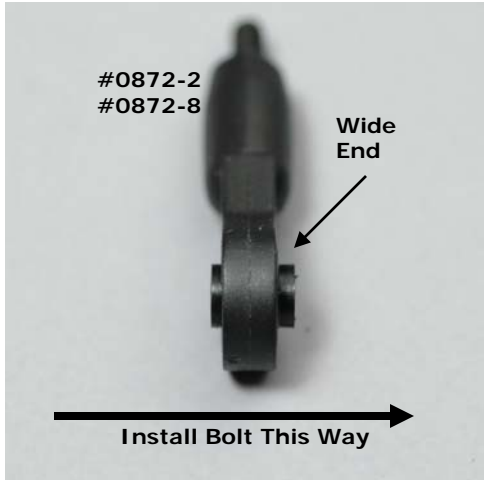

11C.2.b

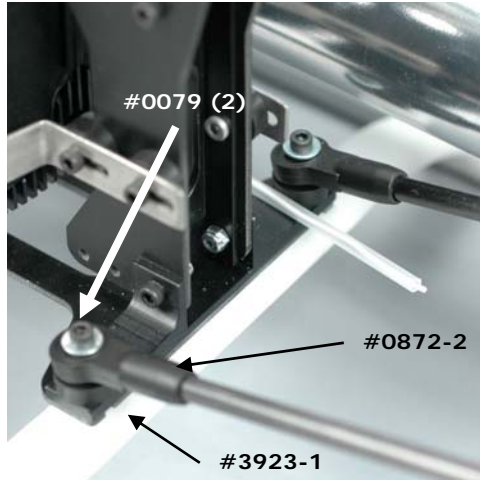

11C.2.b

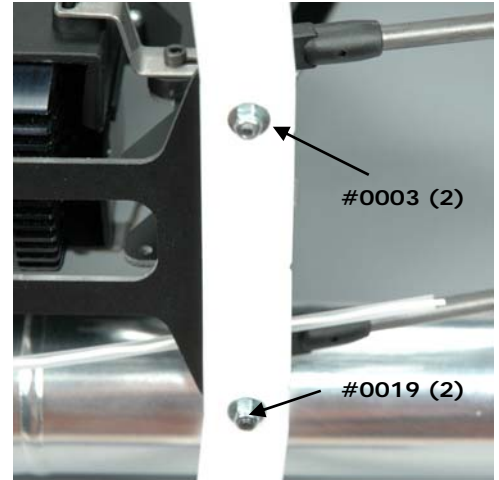

11C.2.d



11C.2.e



11C.3 – Install Rotor Blades

11C.3.a

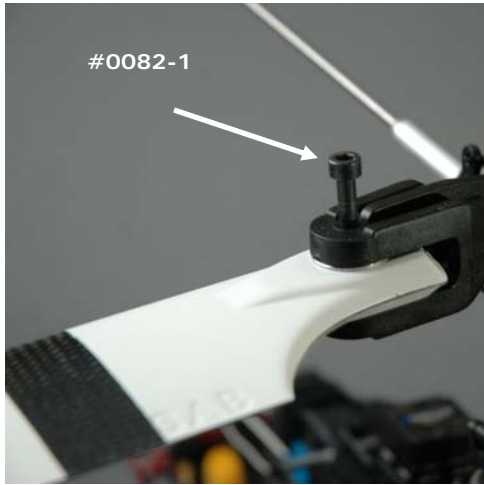

11C.3.b

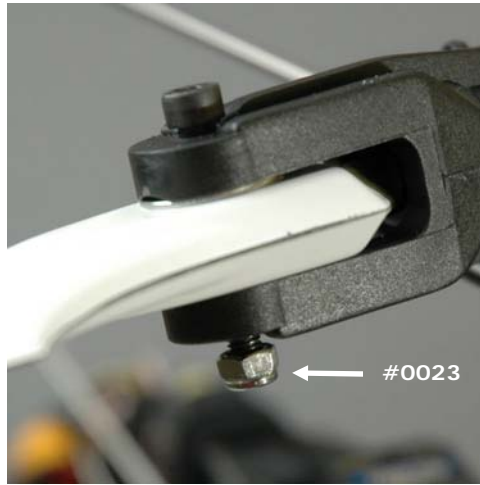

Building Notes – Tighten each blade equally. The blade should be tight enough to be hard to move in the blade holder.

11C.4 – Install Canopy

11C.4.a

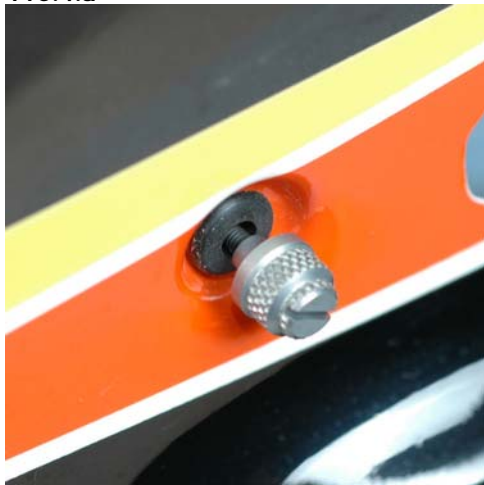

11C.4.b

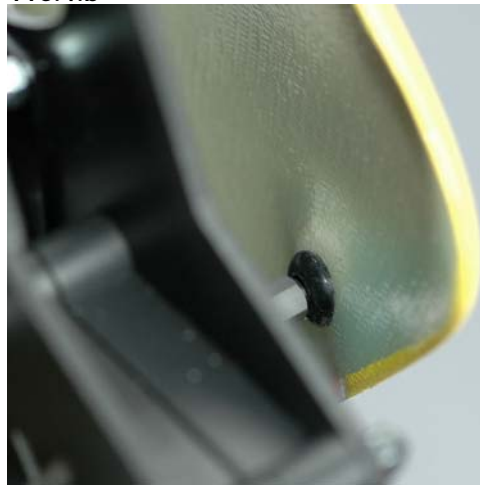

11C.4.c





