

# FOCUS 4

## 4 CHANNEL F.M. SYSTEM AIRCRAFT

### OPERATION MANUAL

ENGLISH

영어

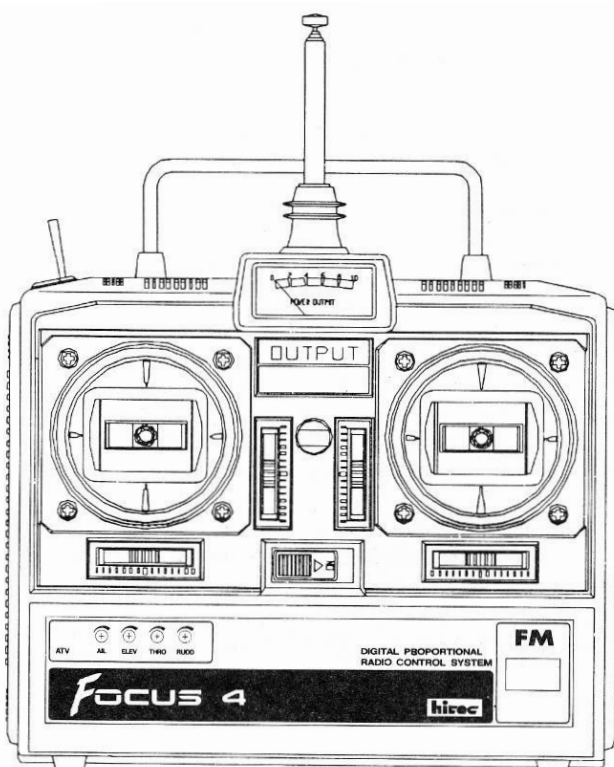

hitec

The Hitec Focus digital proportional radio control system is a highly sophisticated system that features modern solid state circuit design and components of unsurpassed reliability. The time you spend learning about your Focus from this manual will ensure you that you will enjoy many years of dependable control.

# 1. Contents

1. Contents .....	1.
2. Features & specifications .....	2.
A. Transmitter	
B. Receiver	
C. Servo	
3. Transmitter function .....	3.
A. Front	
B. Back	
4. Receiver & servo connection .....	4.
5. Operation & adjustment .....	5.
A. Control stick tension & length & trim lever adjustment	
B. Servo reverse	
C. Aileron and elevator & rudder & throttle A.T.V.	
D. Innovative MASTER-STUDENT trainer system	
6. Installation .....	7.

## 2. Features & specifications

### A. Transmitter

- 4 channel P.P.M/F.M transmitter
  - AMA listed 1991 F.M system and RCMA gold stickered transmitters.
  - High quality precision gimbal stick with adjustable length & tension.
  - All channel servo reversing
  - ATV for aileron, elevator, rudder, throttle
  - Trainer system
  - Innovative "MASTER-STUDENT" trainer cable system
- |                      |                              |
|----------------------|------------------------------|
| Operating system     | : 2 stick system             |
| Module change system | : Internal module system     |
| Power supply         | : 9.6V (8 Ni-CAD batteries)  |
| Current drain        | : 150mA (13.5) -130mA (10.8) |

### B. Receiver (Ultra series)

- X-TAL interchangeable
  - Ultra narrow band width for maximum adjacent channel rejection.
  - Minimized 2nd & 3rd order intermodulation
  - Metallic noise proof
- |                        |                                    |
|------------------------|------------------------------------|
| Intermediate frequency | : 455 KHz, 10.7 MHz                |
| Power supply           | : 4.8V (4 NiCd battery) AA size    |
| Current drain          | : 22mA                             |
| Dimensions             | : 37 x 61x22 mm (1.5" x2.4" x0.9") |
| Weight                 | : 45.50g(1.66oz)                   |
| Receiving range        | : 1,000 ft or greater in the air   |
| Working voltage        | : 3.7-7.0V                         |

### C. Servo

- Top oilite bearing prevents wearing out of the top plastic case
  - Indirect drive for gear train protection
  - Hitec custom designed 1.C with narrow dead band & high trackability
  - SMT(surface Mount Technology) circuitry adopted.
  - Precise & sturdy heavy duty gears improve high neutral position and minimal backlash.
- |                 |   |
|-----------------|---|
| Control system  | : + pulse width control (1550 uS/N)                 |
| Operating angle | : One side 45deg or more (including trim)           |
| Power supply    | : 4.8V (4 NiCd) or 6V (4 alkaline battery) AA size. |
| Current drain   | : 8mA at 6.0V (stopped)                             |
| Output torque   | : 3.0kg/cm (41 oz in)                               |
| Operating speed | : 0.21 sec/60deg                                    |
| Dimensions      | : 41x20x36mm (1.6x0.8"x 1.4")                       |
| Weight          | : 1.51oz(43g)                                       |

### 3. Transmitter function

#### A. Front

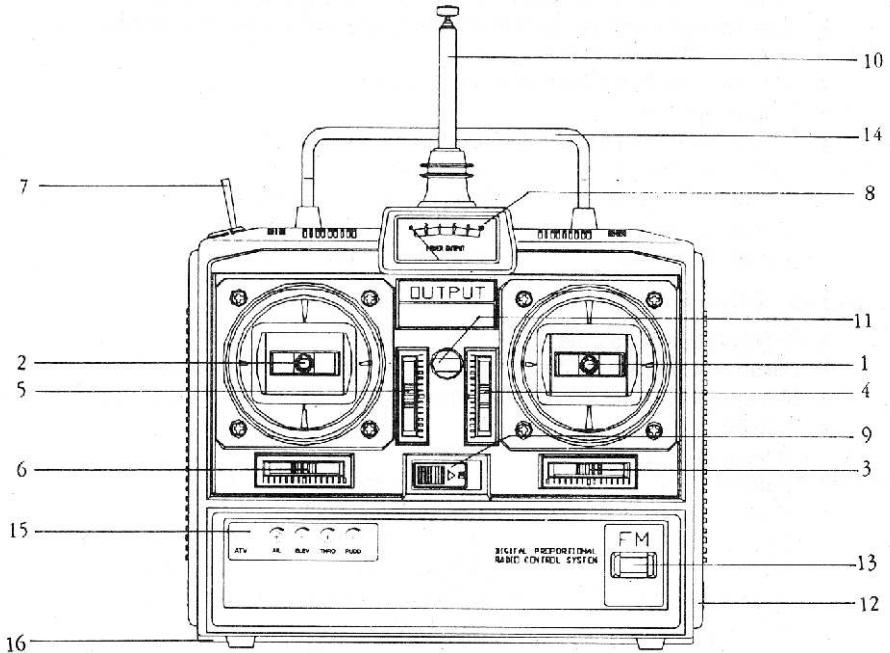

Fig 1

- 1 Aileron/Elevator stick in MODE II
- 2 Throttle/Rudder stick in MODE II
- 3 Aileron trim
- 4 Elevator trim
- 5 Throttle trim
- 6 Rudder trim
- 7 Trainer ON-OFF switch
- 8 ISJ Level meter
- 9 Power switch
- 10 Rod antenna
- 11 Neck-strap connector
- 12 Recharge Jack

- 13 Crystal
- 14 Handle
- 15 Aileron & elevator and rudder and throttle adjustable travel volume(A.T.V)
- 16 Servo reversing switches
- 17 Nicad-battery
- 18 Trainer Jack

Unlike conventional trainer system, our trainer cable designates the "MASTER" end & "STUDENT" end. When connected properly, the student transmitter will not activate even if the student accidentally turns his radio "ON".

"Power switch should be off when charging"

B. Back

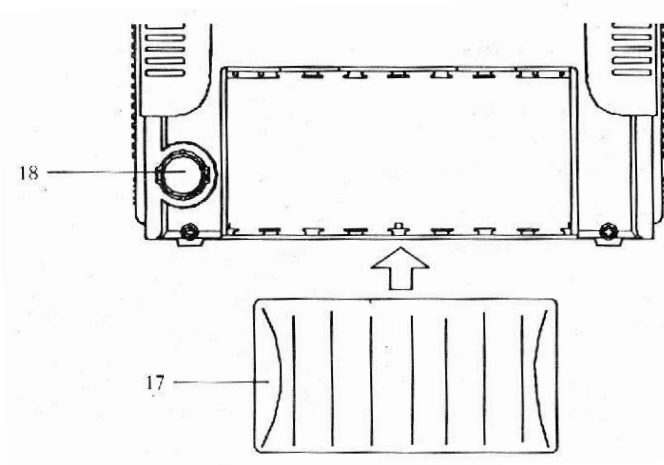

Fig 2

4. Receiver & servo connection

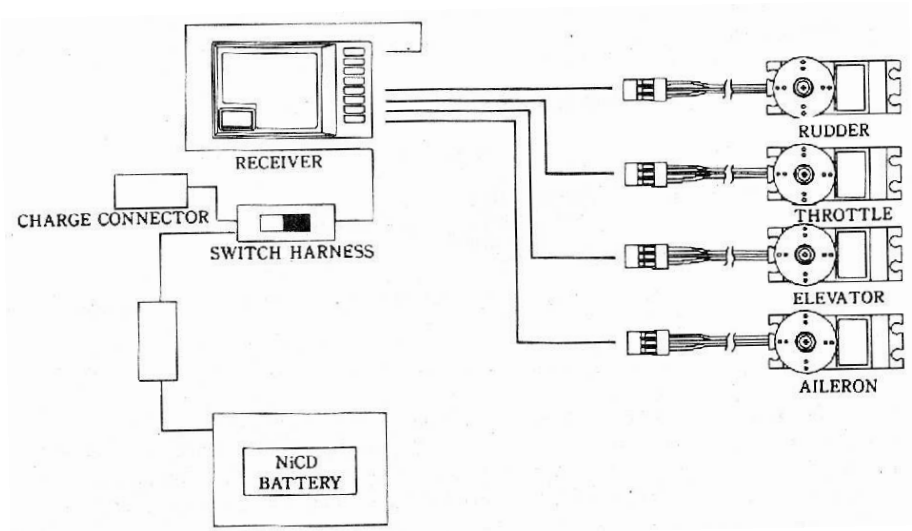

Fig 3

## 5. Operation & adjustment

### A. Control stick length & tension & trim lever adjustments

The unique open-stick assembly provides fully adjustable stick tension "feel". Turning the tension adjustment screw clockwise will soften ( decrease the tension ) the feel of the control stick, (fig 4).

CP-variable resistors improve the neutral characteristics and resolution of the servo positioning.

All of the molded parts are fabricated from high-grade polycarbonate that is unaffected by temperature and humidity.

Turn with a Phillips screwdriver  
The spring becomes stronger when the screw is turned counterclockwise

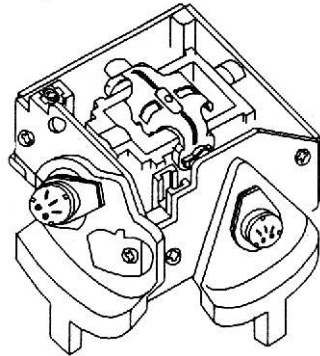

Fig 4

The length of the nonslip control sticks can be adjusted to suit the requirements of the operator. (fig-5)

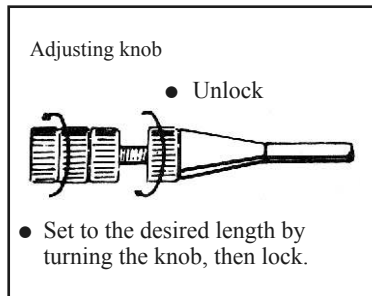

Fig 5

The trim lever on each control stick is used to correct ( trim out ) flight characteristics. After the initial test flight note the positions of the control surfaces that required trim. Next center trim levers, turn off the receiver radio. Now adjust the control devices of the surfaces that required trim so that the surfaces are in the same position before the trim levers were re-centered. Turn on the receiver radio and recheck the control surface to ensure that all the corrections were applied in the correct direction.

## B. Servo reverse

The Focus 4 F.M transmitter is equipped with servo reversing on all 4channels.

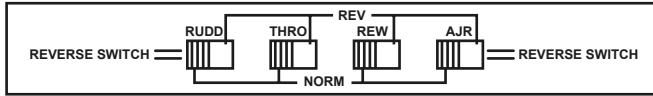

Fig 6

( Note : Leaving the reverse switch in the middle will cause the radio to work erratically so please make sure that the switches are all pushed to the furthest end. )

## C. Aileron and elevator & rudder & throttle adjustable travel volume (A.T.V.)

This function adjusts the servo left and right throws on aileron and elevator and rudder and throttle. The rate setting range is 30% to 110%.

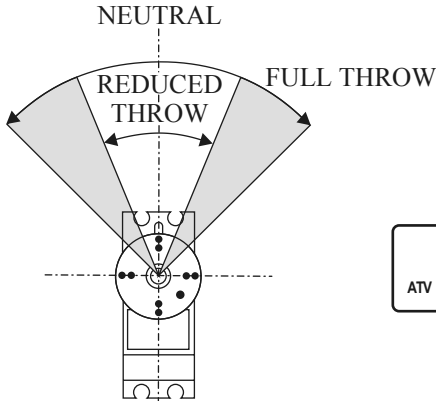

Fig 7



Fig 8

## E. Innovative MASTER-STUDENT trainer system

Pulling down the trainer switch will switch over the control to the student transmitter. Releasing the switch will enable master transmitter to resume control. When attaching the trainer cable (optional item sold separately. Spare part # 8310 : one way trainer cord) the cable must be connected to the correct side as the master side should be connected with the master transmitter. The purpose is obvious. Connected properly, the student transmitter cannot be activated even if it is accidentally turned on, a unique feature not present in other systems.

## 6. Installation

- Connect the servos, batteries and switch harness in accordance with fig 3. Carefully check to ensure that all connectors are properly seated.
- Turn the power switches "ON" and operate the transmitter. Observe the direction of travel of the control surfaces to see if they correspond to the control stick movement. Improper servo direction is corrected with the servo reverse dip switches, (fig 3)
- Operate each servo over its entire range and check for binding of the push rods. Correct as necessary. Hold each control stick at its extreme position and listen for servo hum. The hum indicates that the control linkage is too tight for the amount of servo travel. This is corrected with the end point adjustment or by lengthening the push rods.
- Applying unreasonable force to a servo output arm will adversely affect the servo and quickly drain the flight batteries. Therefore, all control linkages should operate as smoothly and as frictionless as possible. Use Hitec "Jam Check'r" to assure smooth, safe control setups.
- When installing the switch, cut a rectangular hole somewhat larger than the full stroke of the switch, then install the switch so it moves smoothly from ON to OFF.
- The length of the receiver antenna is critical to the reception of signals transmitted, therefore DO NOT cut or bundle the antenna wire, make every effort to keep the antenna wire fully extended.
- Protect the receiver from excessive vibration by wrapping it in sponge rubber (note: Use Hitec "Flight Preserver : #8480"). Next place the receiver in a plastic bag. Secure the plastic bag with rubber bands to keep out moisture and dust.
- Collapse the transmitter antenna fully and operate the system from a distance of 60 to 90 feet. The system should function flawlessly. If it does not, check to see that the receiver and transmitter batteries are at maximum capacity.

### Charging Instructions

- Before first use of Focus system, connect appropriate charge connectors from charger to transmitter and receiver switch harness with battery connected.
- With transmitter and receiver switched OFF, plug charger into 110-120V AC and be sure the RED & GREEN charge lights are ON. If either charger light is OFF, re-check connections to charger and be sure switches on transmitter and receiver are OFF.
- Charge for 24 hours first before further use of system. This conditions the batteries for full-charge capacity.
- Re-charge 16-20 hours immediately before each flying day.

