

# AIR WOLF

## INSTALLATION MANUAL

ENGINE SIZE:50

NOTICE: USE EPOXY UNLESS STATED.  
SAND INSIDE FUSELAGE WITH #180 SANDING  
PAPER BEFORE PARTS GLUING IN PLACE.

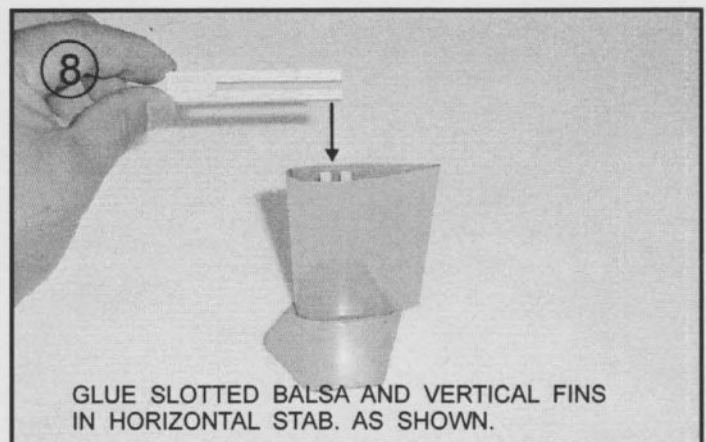
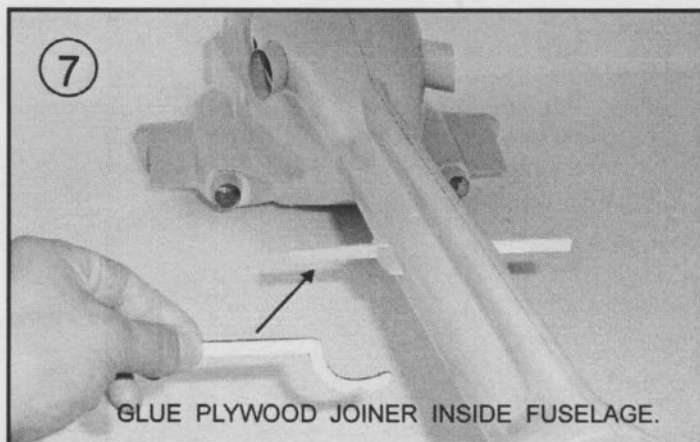
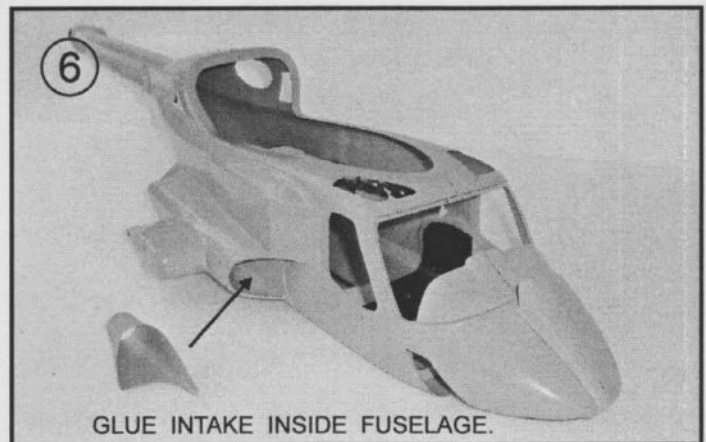
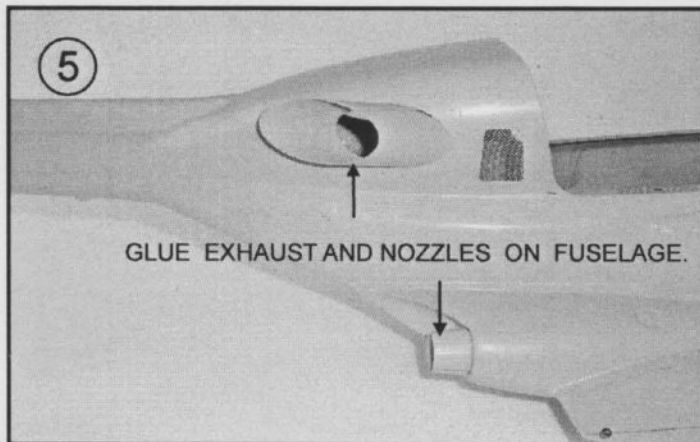
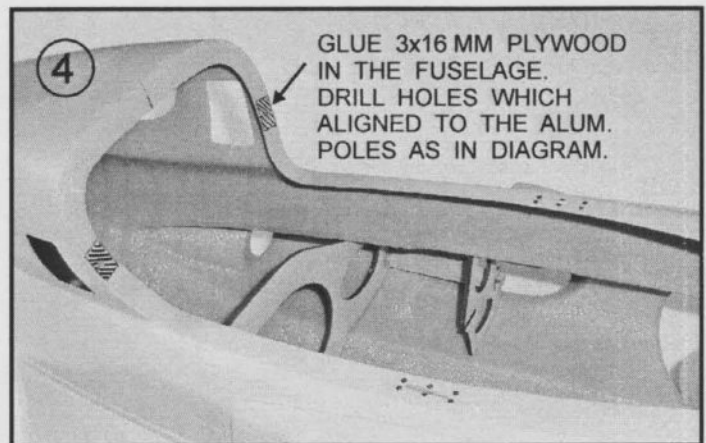
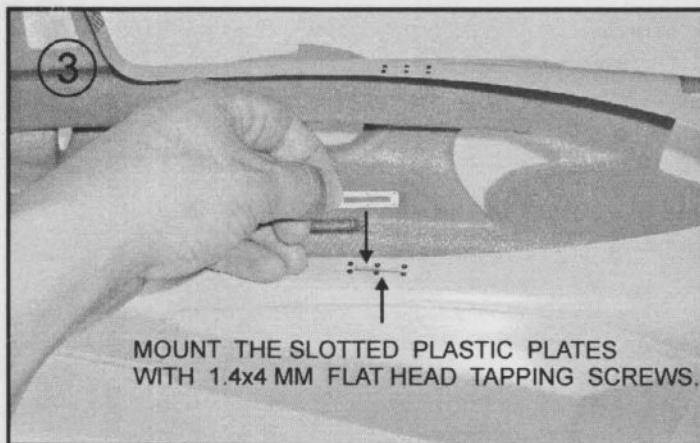
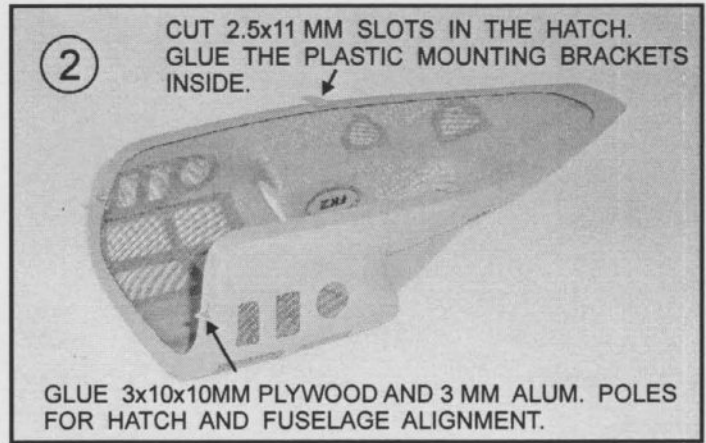
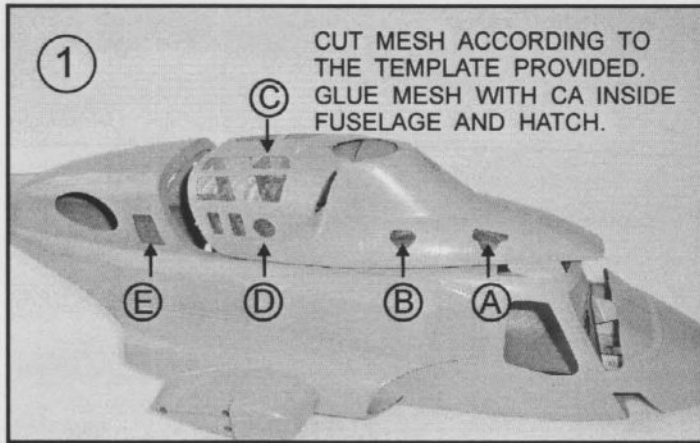

# AIR WOLF

## INSTALLATION MANUAL

ENGINE SIZE:50

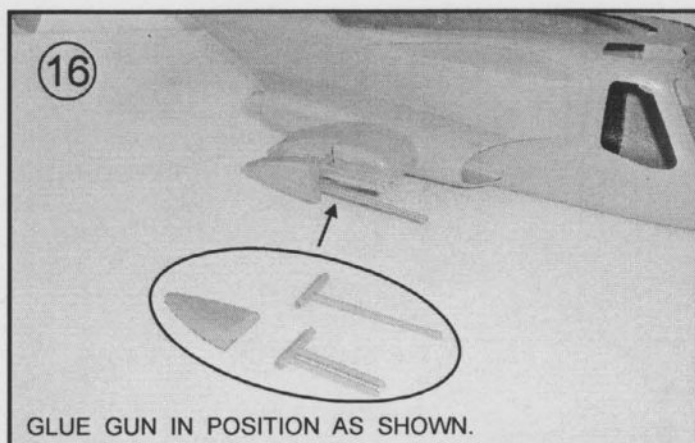
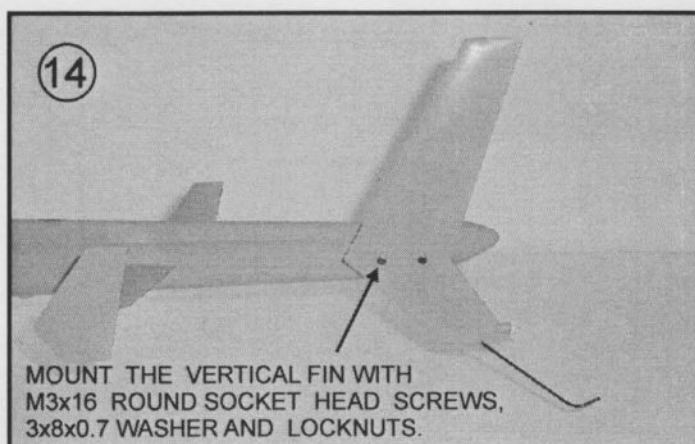
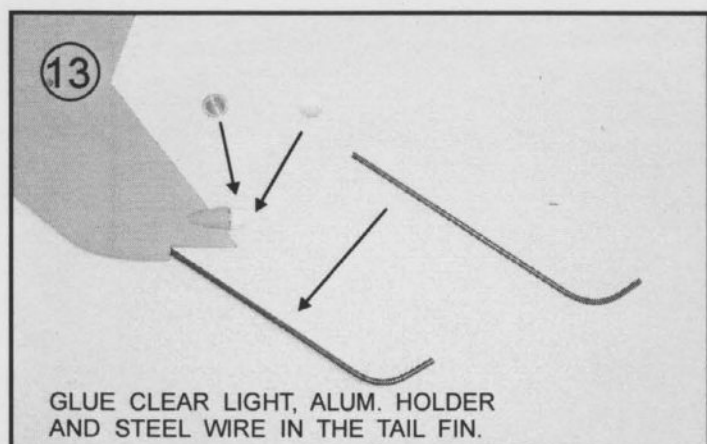
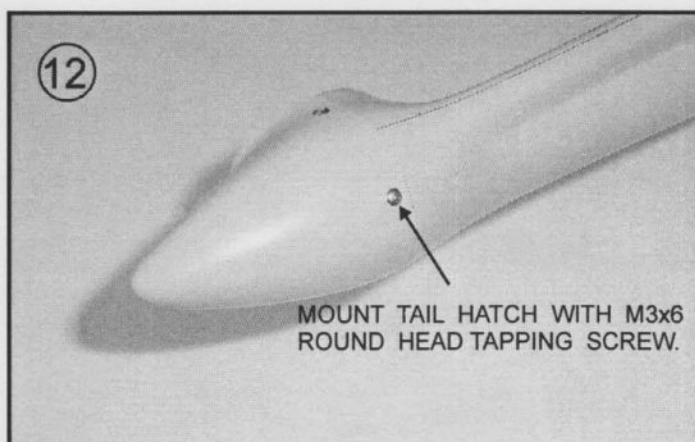
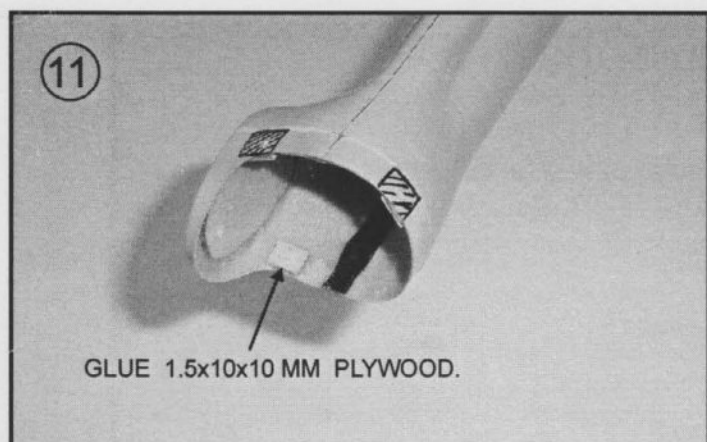
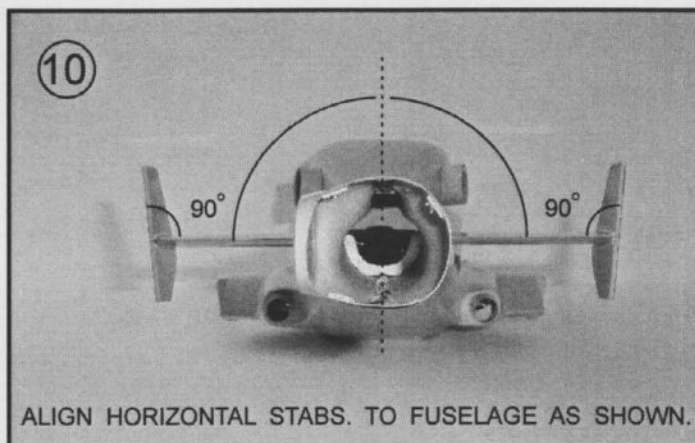
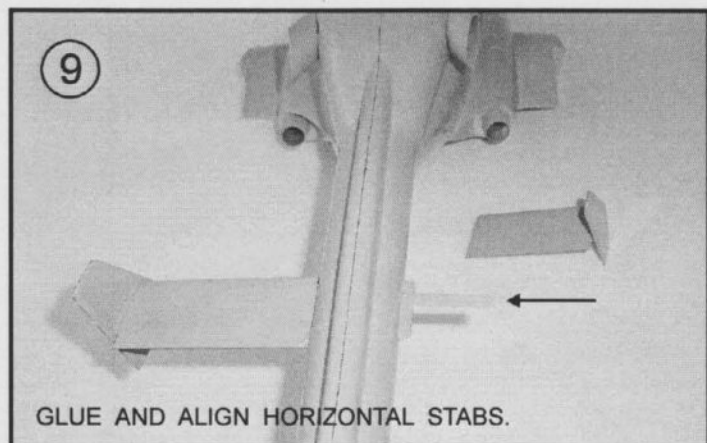

# AIR WOLF

ENGINE SIZE:50

## INSTALLATION OF RETRACTABLE LANDING GEAR

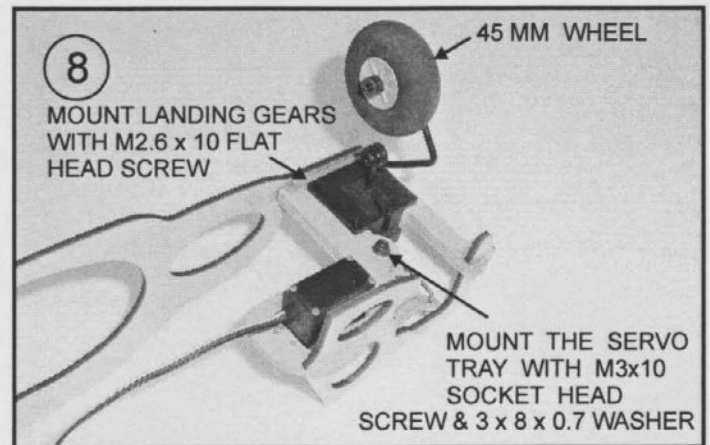
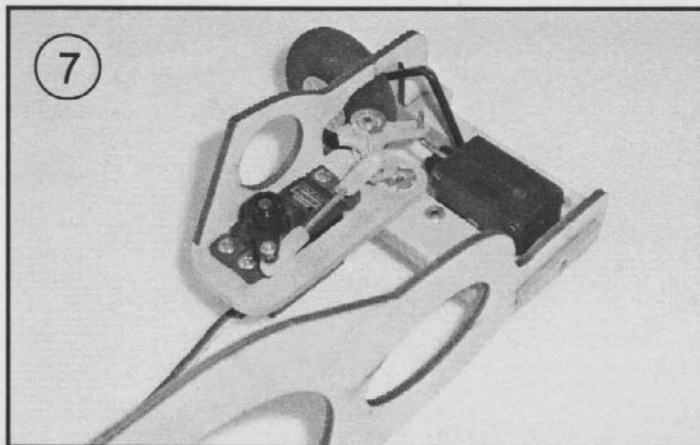
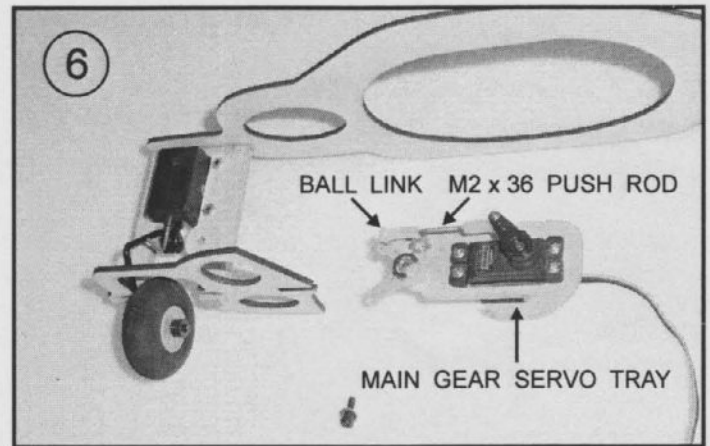
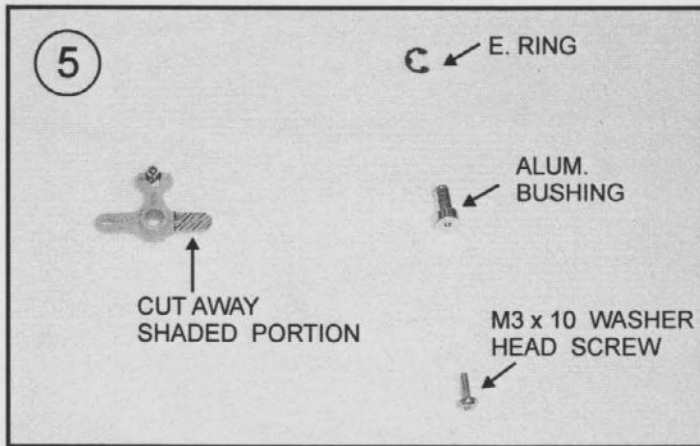
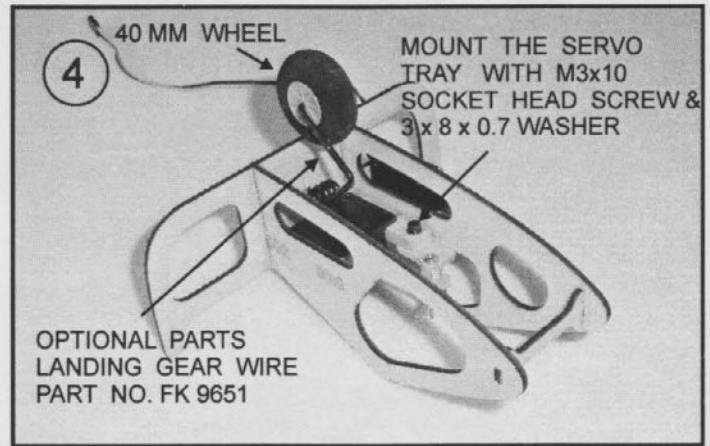
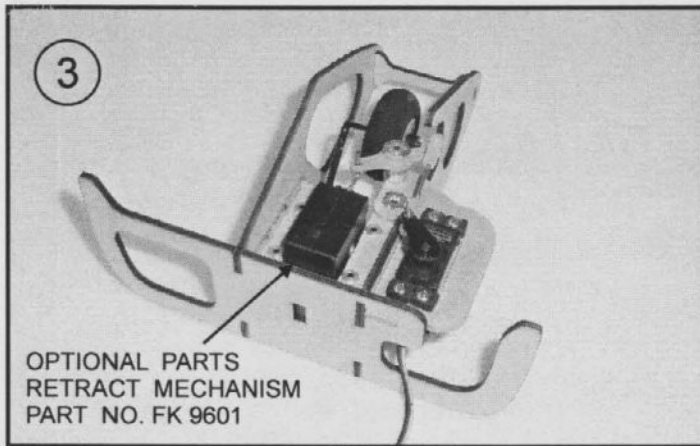
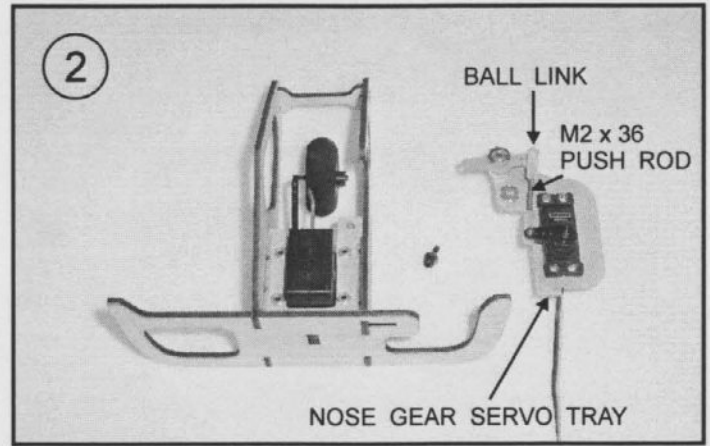
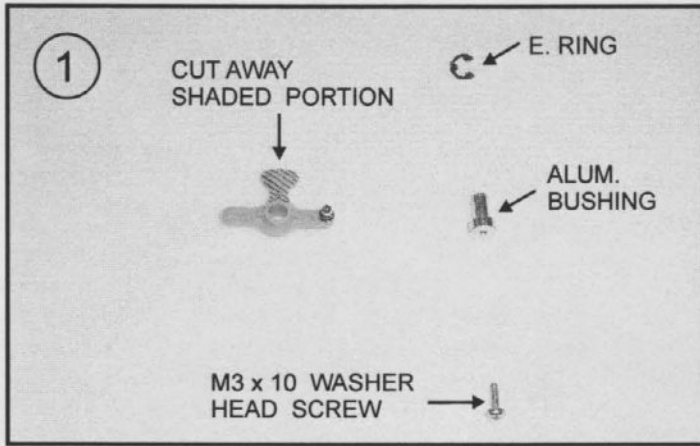



# AIR WOLF

ENGINE SIZE:50

## INSTALLATION OF CENTURY SCALE SE MECHANISM

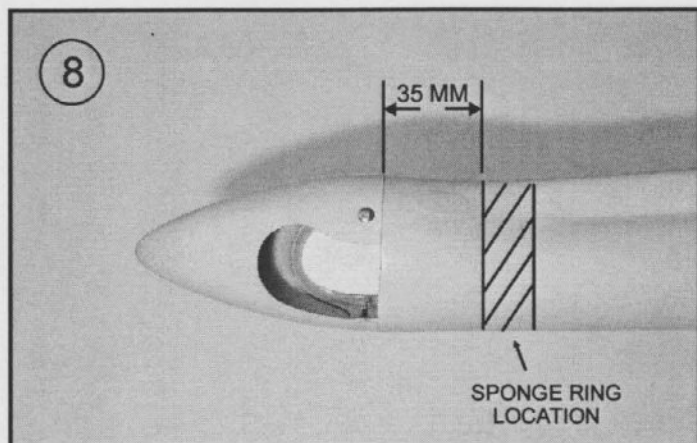
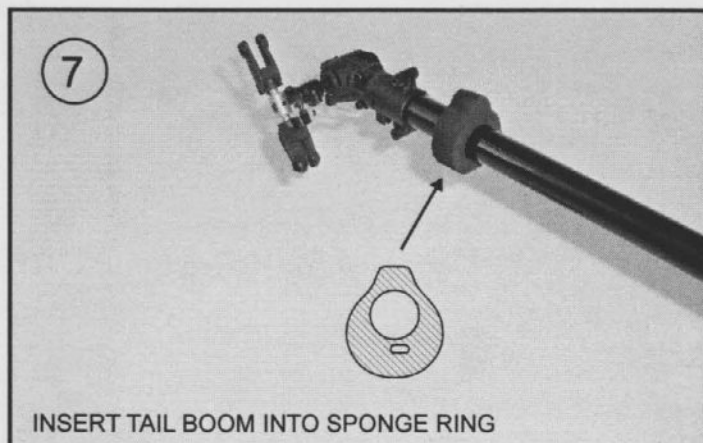
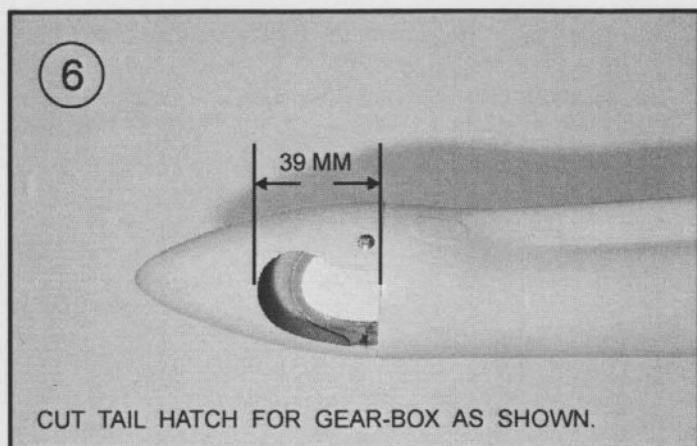
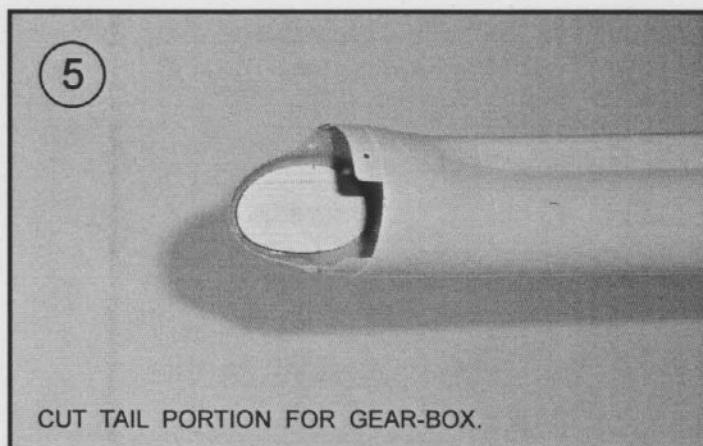
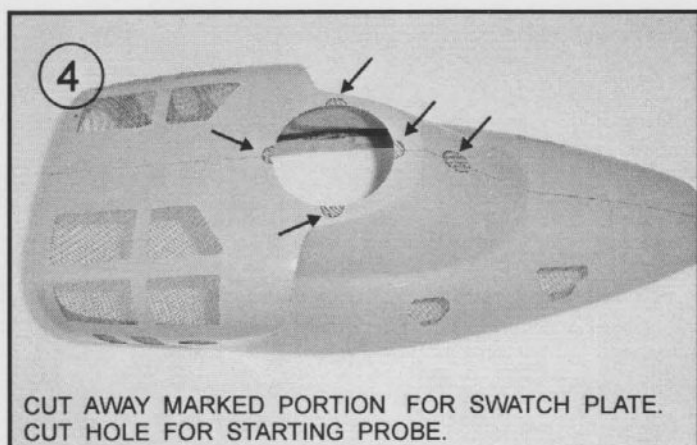
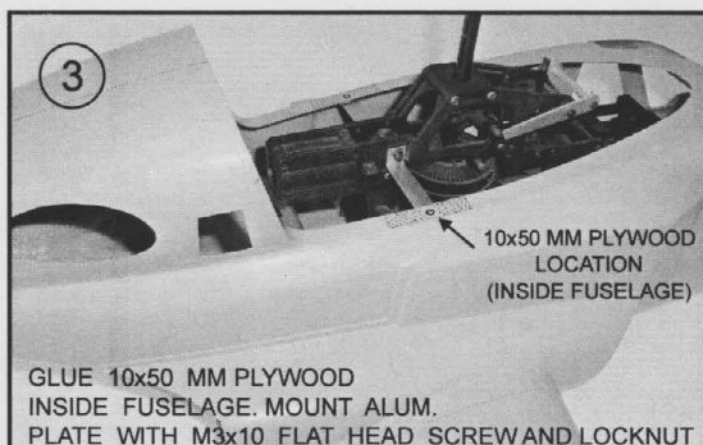
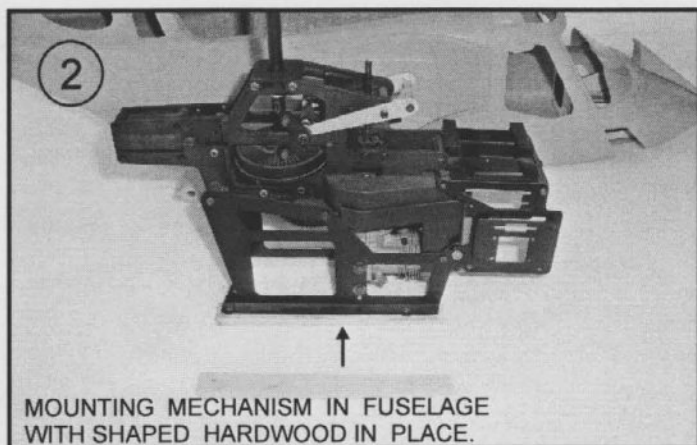
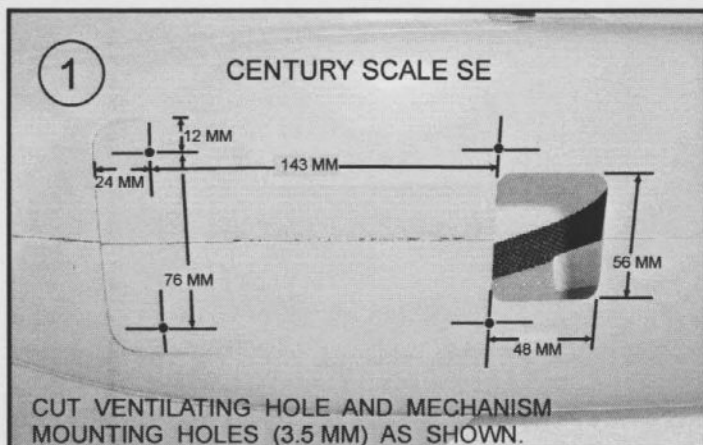

# MESH TEMPLATE (SCALE 1:1) FOR BELL 222 (50) / AIR WOLF (50)

