

AuroraTM

Ultimate 90



Aurora

AMT

AVANT Aurora Ultimate 90

Assembly Manual V1.08

LIABILITY DISCLAIMER

This kit is for a radio controlled (RC) helicopter. RC Helicopters are not toys. Moving parts can present a hazard to operators, bystanders and anyone or anything that could be reached by the RC helicopter. Improper operation, maintenance or assembly can potentially cause a helicopter to pose a danger to persons or objects including but not limited to the possibility of causing serious physical injury and even death. This product is intended to be used by experienced adult radio control helicopter pilots under controlled safety conditions and on locations properly authorized and setup for safe flying and away from other people. Under no circumstance should a minor be allowed to operate this or any radio controlled helicopter without the approval, supervision and direction of his parent or legal guardian who takes full responsibility for the minor's actions. Do not operate an RC helicopter within the vicinity of homes, trees, electrical lines during inclement weather or rain or near crowds of people. After leaving its facilities the manufacturer has no way of maintaining control or supervision over the assembly and/or operation of the helicopter.

The manufacturer and/or its agents assume no responsibility or liability whatsoever for any damages including but not limited to ones generated by incidental or consequential damages.

The operator of the helicopter assumes all responsibility and liability that could be result from the correct or incorrect operation of the helicopter.

Symbols:

 Important,  Correct,  Incorrect,  Danger,  Allow it to set for some time before continuing

Note: Unless indicated otherwise all screws, balls and threads are installed with Blue Loctite



Before you start assembling:

Get the latest manual: It's highly recommended that you get the latest version of the manual. Please [download a copy by clicking here](#) and use that copy instead of this one.

Important: Using a piece of #400 sanding paper sand the edges of the carbon fiber pieces that will be close to any electronic wires or fuel tubing. Sharp edges can cut into the electric wires and since carbon fiber is conductive it can possibly create an electrical shortcut. Sharp edges can also cut fuel tubing creating leaks that could make the engine operation fail. Whenever you're ready to install a carbon fiber piece that will be close to servo wiring make sure to sand its edges to prevent wire chafing and a possible electrical short circuit.

Bag #1: Left Frame assembly, Motor Mount Center and Gyro Mount.

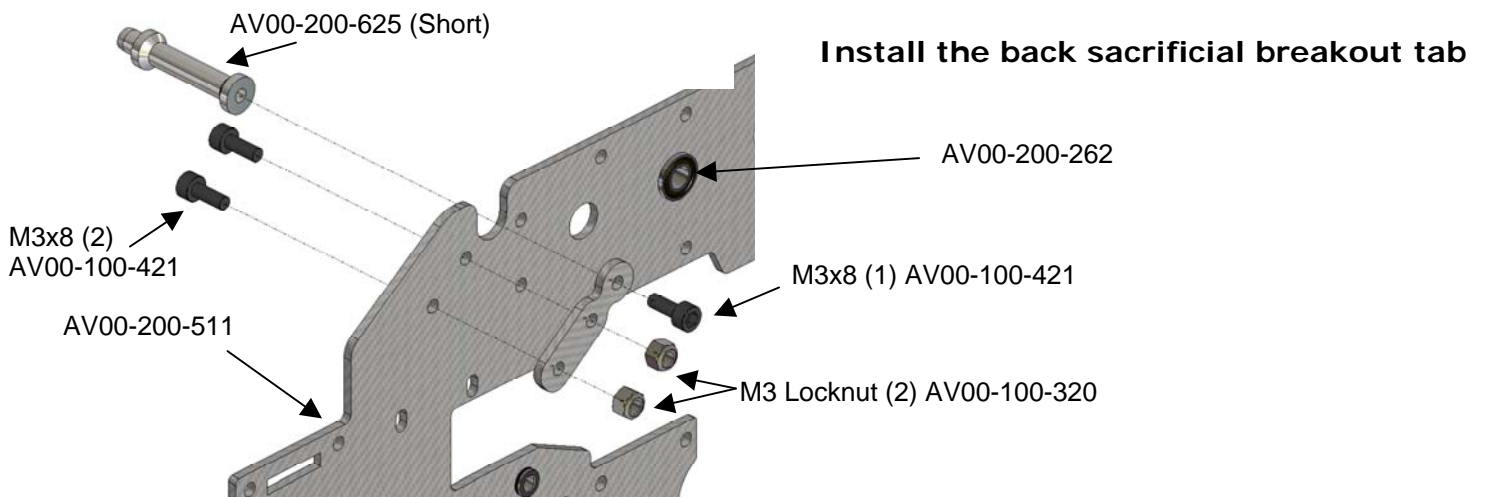

Install the front canopy mount

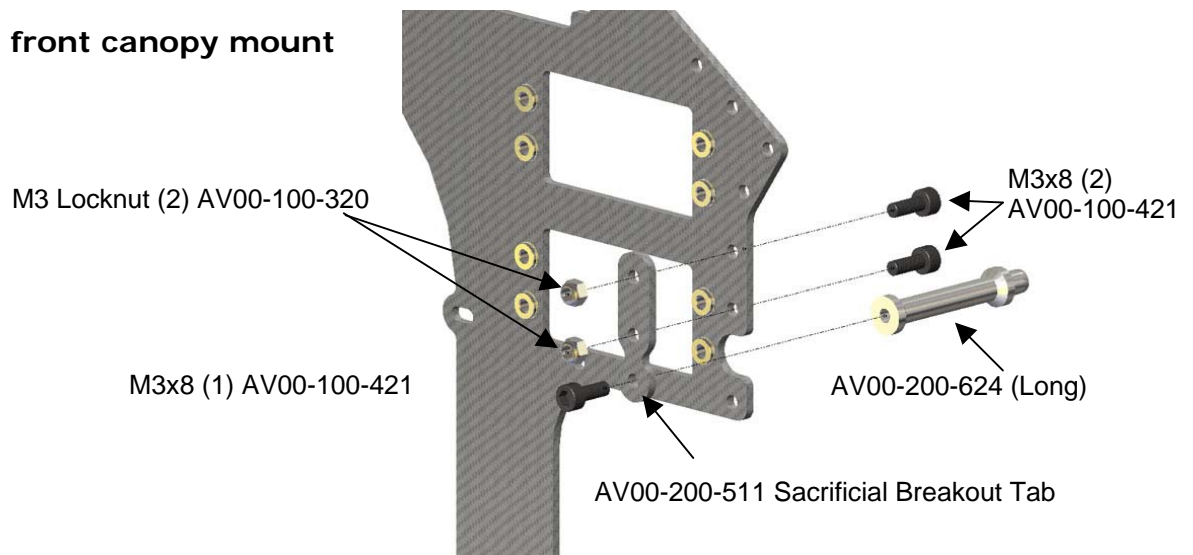

Note: Unless indicated otherwise all screws, balls and threads are installed with Blue Loctite

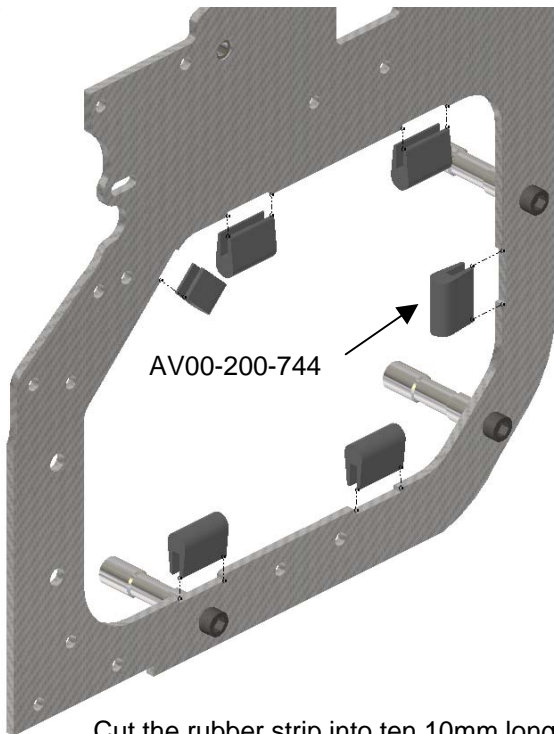
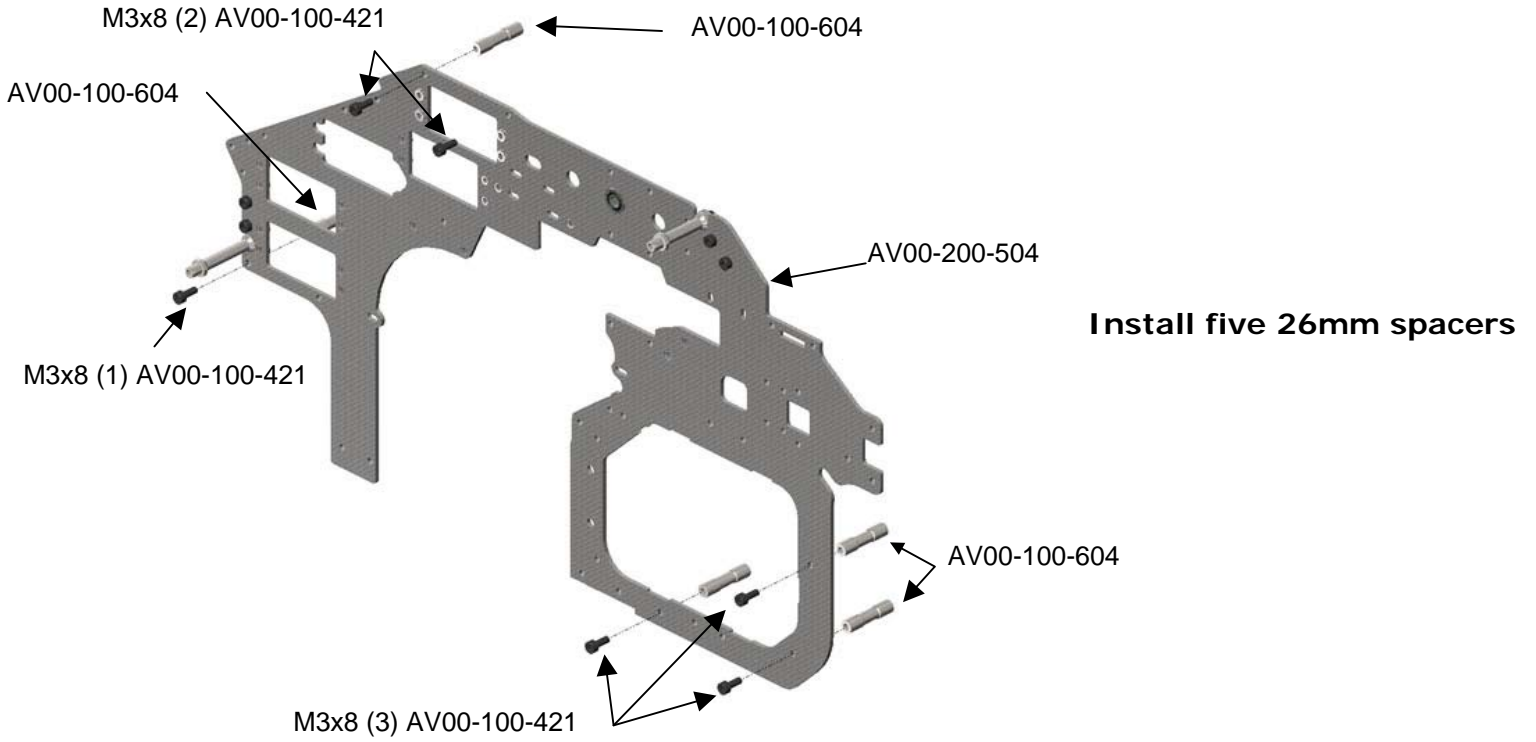

Cut the rubber strip into ten 10mm long. You will use half of them on the left frame and the other half on the right frame. Using CA glue install the tank rubber mounts

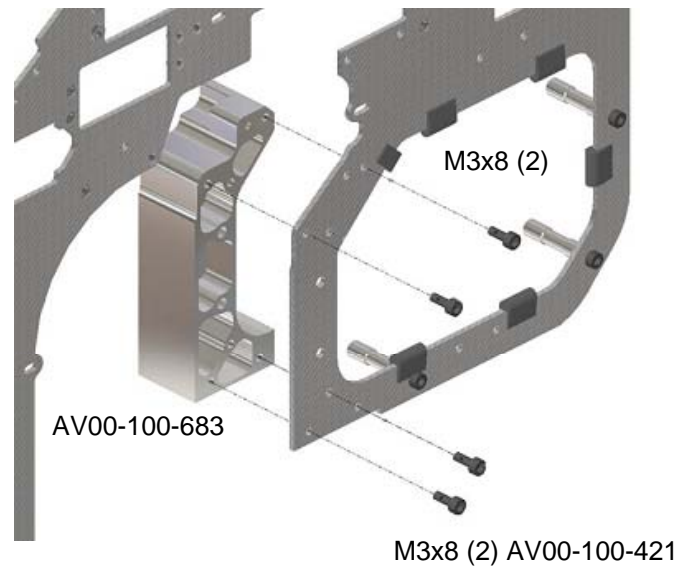

Note: Unless indicated otherwise all screws, balls and threads are installed with Blue Loctite

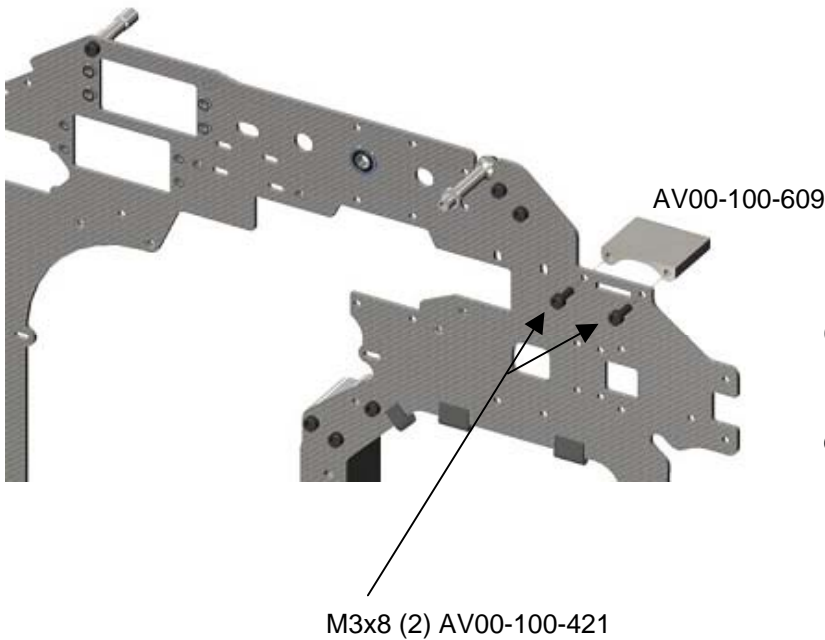

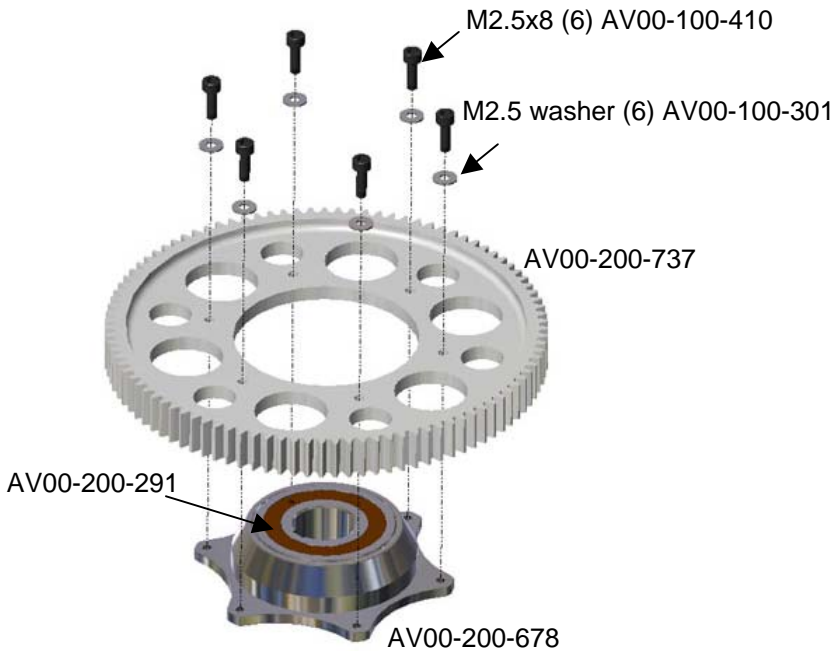

Using two M3x8 screws install the Gyro mount plate. Do not use blue Loctite yet because they will be loosened later during the installation of the boom clamp.

Bag #2: Main Gear assembly, Main shaft installation and Left side frame stiffener

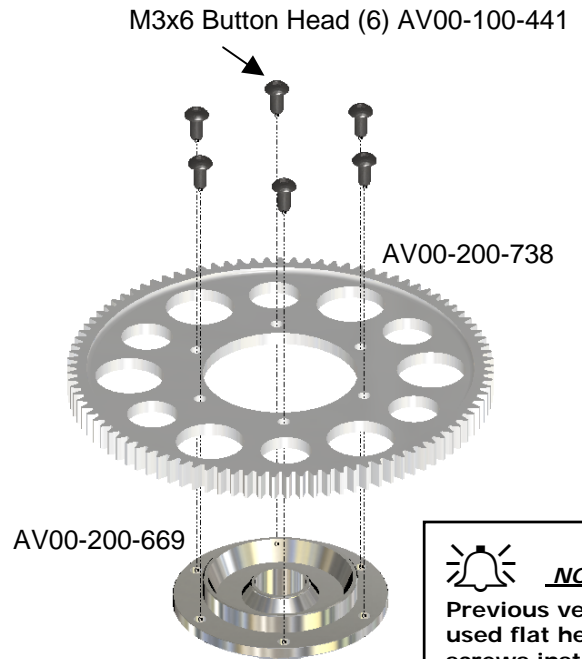

Using six M2.5x8 screws install the Main gear onto the pre-assembled main gear hub



 **NOTE:**
Previous version used flat head screws instead of button head.

Using six M3x6 button head screws install the constant drive gear onto the constant drive hub.

Note: Unless indicated otherwise all screws, balls and threads are installed with Blue Loctite

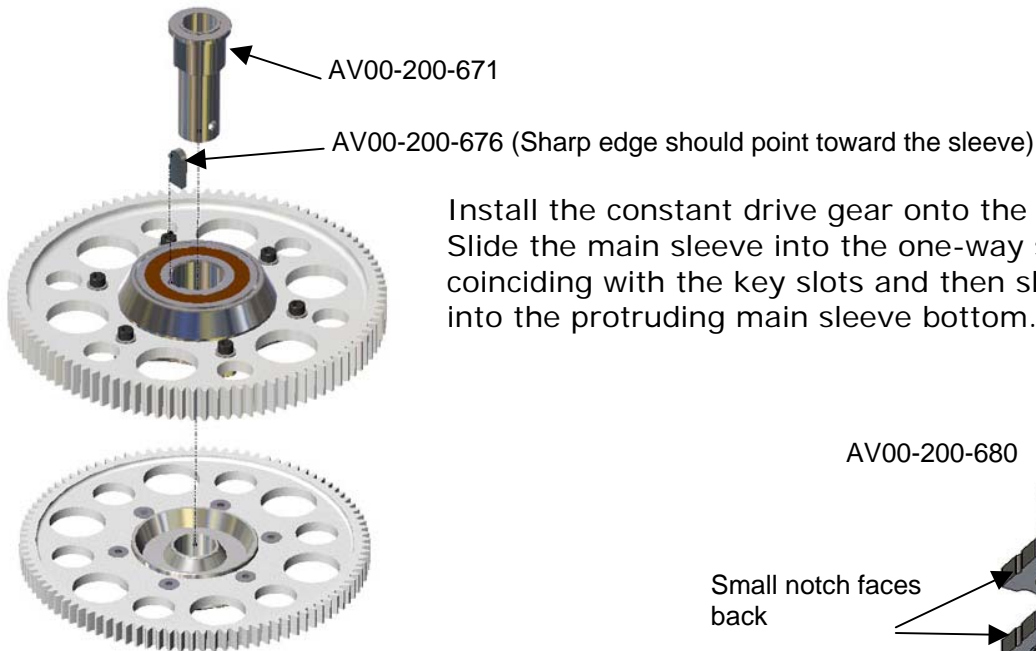

Install the constant drive gear onto the constant drive gear hub. Slide the main sleeve into the one-way sprag clutch with the key coinciding with the key slots and then slide the constant gear hub into the protruding main sleeve bottom.

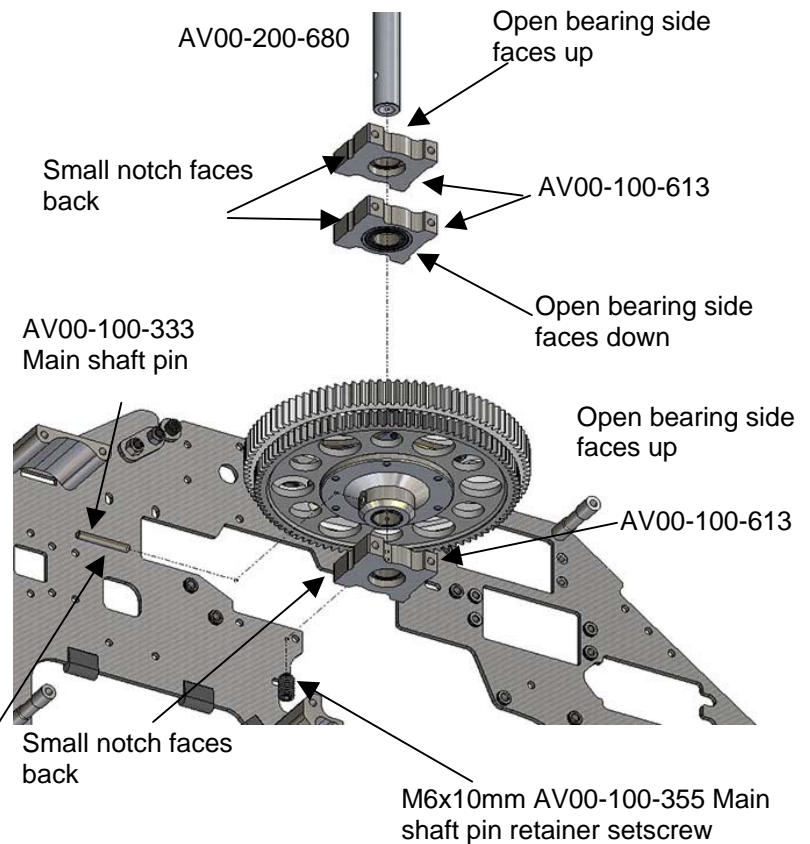

Slide the Main Shaft into the main gear assembly and install the hardened pin that locks the constant drive hub into the main shaft and screw the M6x10 setscrew into the bottom of the main shaft to secure the pin in place, There is no need to over tighten this setscrew. Slide the top bearing blocks and the bottom bearing block oriented as indicated by the small notched facing the back. Notice that the small notches for the entire bearing block should be facing the rear side of the heli.



IMPORTANT NOTE: Use Blue Loctite on the mainshaft pin itself. This will prevent it from sliding out even if the setscrew becomes loose.



IMPORTANT NOTE: Pay attention to the orientation of the bearing blocks. The top block open bearing side should face up, the mid one should face down and the bottom one should face up.

For the next step hold pressure on the main shaft's middle and bottom bearing blocks against each other while tightening the bearing block's bolts shown on the next illustration. No play should be allowed in between the blocks and the main sleeve. This is the main means of holding the main shaft in place so no play should be allowed.

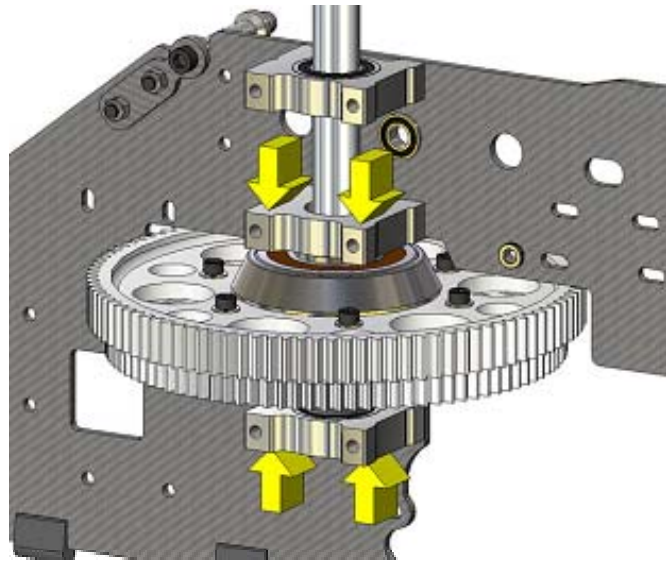

M3x8 (1) Button (Round) Head AV00-100-442

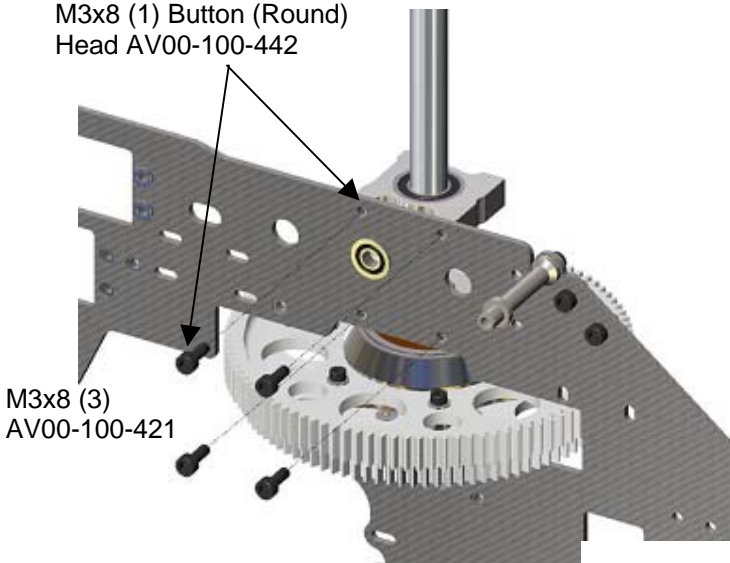

M3x8 (3) AV00-100-421

While holding the pressure described above install the M3x8 screws that hold the top and mid bearing blocks in place.

 Notice that one of the M3x8 screws is a button (round) head screw.

Proceed now to install the side stiffener plate by using the spacers and screws provided.

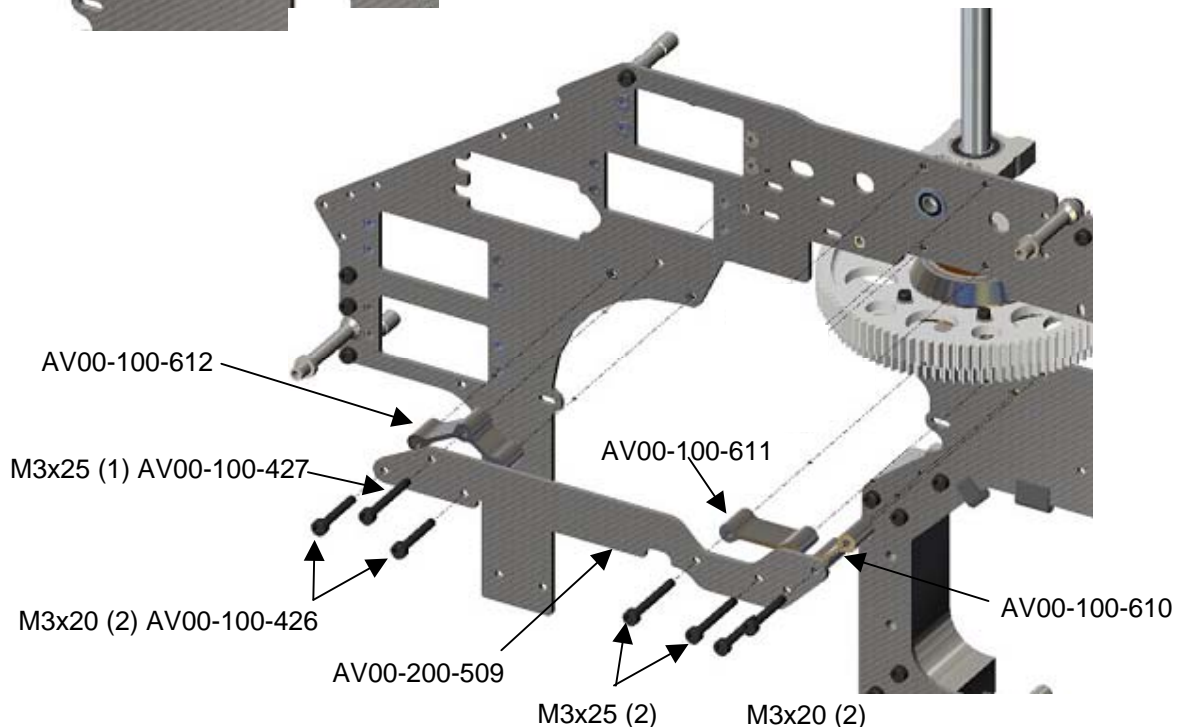

Note: Unless indicated otherwise all screws, balls and threads are installed with Blue Loctite

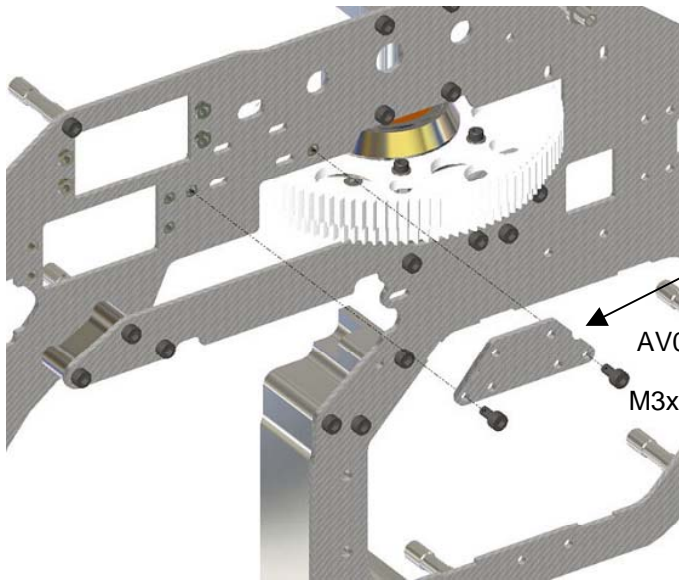

Bag #3: Clutch Stack, Clutch Bell assembly.



Install the gear ratio plate making sure that the notch points toward the back of the helicopter.

AV00-200-506 Ratio plate

M3x6 (2) AV00-100-420

Glue the Clutch liner to the Clutch Bell using 30-minute epoxy making sure to trim the length of the liner strip to match the bell precisely. You can use masking tape around the clutch and use it as a plug to push the liner against the bell wall while it's curing. Assemble the clutch bell stack as shown on the left.

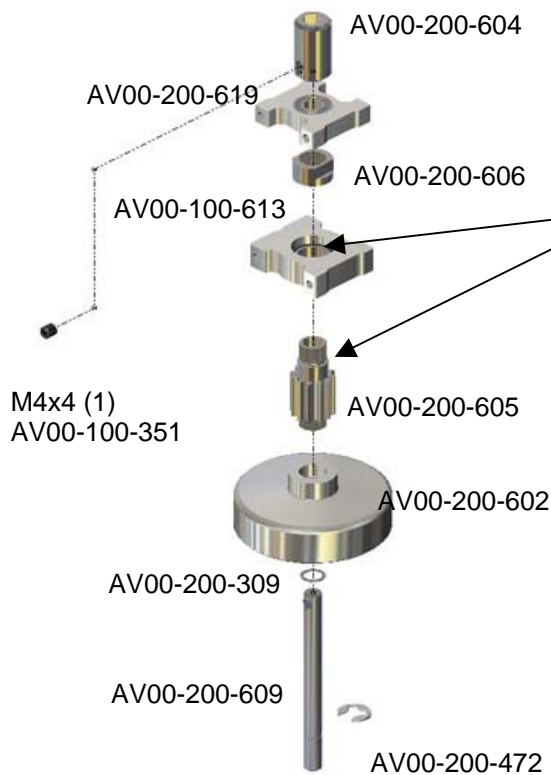

Use red Loctite to lock the pinion into the inner race of the pinion's bearing block. Use Blue Loctite to secure the pinion nut into the pinion.

M3x10 (4) AV00-100-422

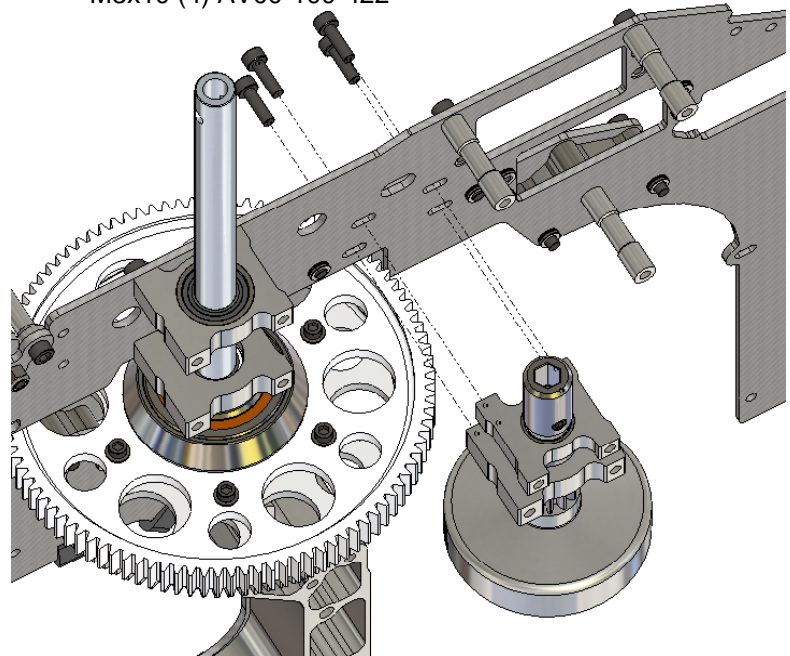

Install the assembly on the left frame using the supplied M3x10 screws to bolt the two bearing blocks. Don't tighten them now wait until the engine is installed to let the starter shaft fit in the clutch first.

Note: Unless indicated otherwise all screws, balls and threads are installed with Blue Loctite

Bag #4: Tail Pickup gear mechanism and gear meshing method.



Assemble the vertical pickup shaft as shown on the left. The roll pin (black one) is the one above and the dowel pin (silver one) is the one at the bottom side.

Assemble the torque input shaft assembly as shown. The spacing between the blocks is set by the holes in the frames.

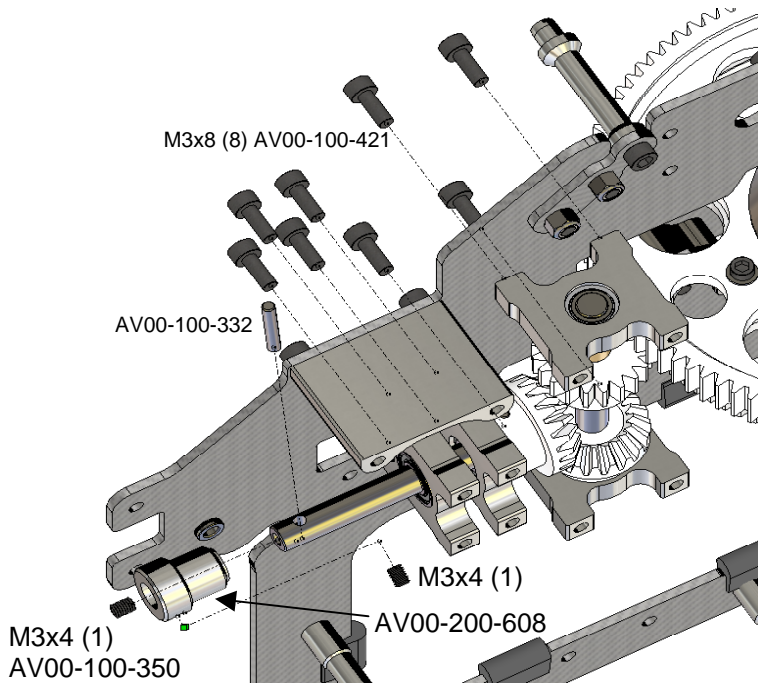
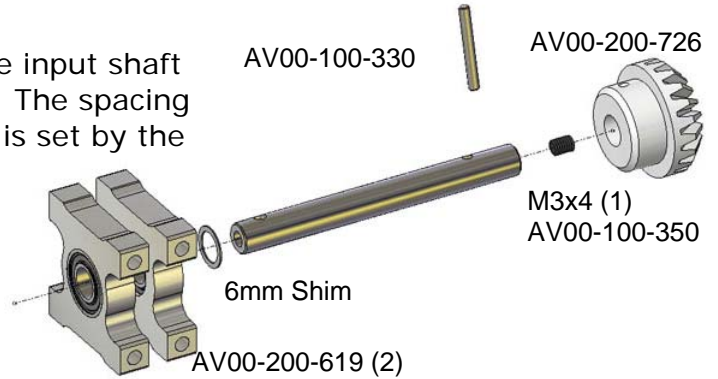

Install the two assemblies into the frame as shown. Don't tighten the collar or the 2.5mm dog-bone pin and setscrew until they are placed in the frames and the mesh is checked for no play at all and flush alignment of the inner face of the teeth on both gears.

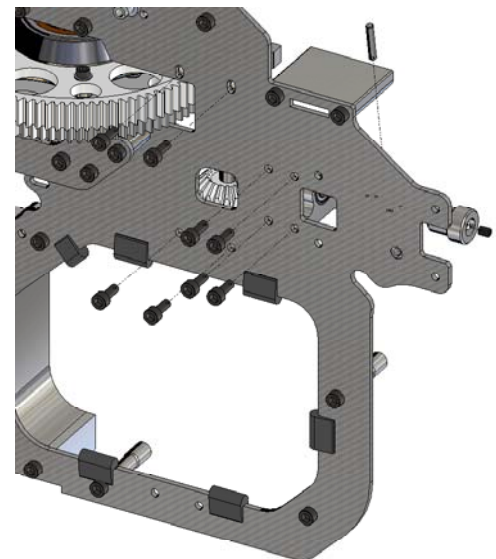

You need to replace the 6mm id bearing spacers until there is no play between the bevel gears. Follow the instructions shown in the next pages for the gear mesh.

- AV00-200-307 - 6mm ID x 0.1mm Shim
- AV00-200-308 - 6mm ID x 0.2mm Shim
- AV00-200-309 - 6mm ID x 0.3mm Shim

Note: Unless indicated otherwise all screws, balls and threads are installed with Blue Loctite



VERY IMPORTANT!!!
READ AND FOLLOW THE TAIL GEAR MESH METHOD
Failure to do so can cause the tail gears to fail in flight

This is the method used to do a correct mesh on the Aurora tail gears. This applies to both the front set (the set inside the frames) and the back set (the set inside the tailcase). The Aurora has a large window to inspect the gears inside the frames as well as the ones inside the tailcase.

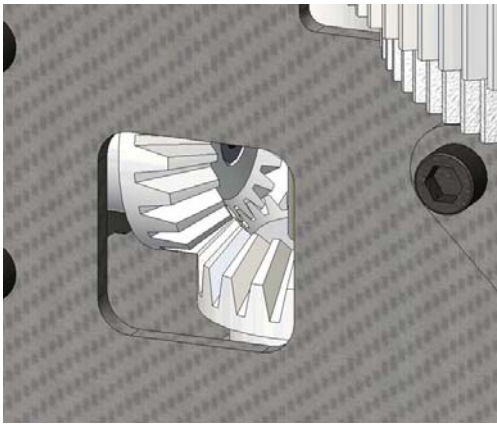

Frame inspection window.

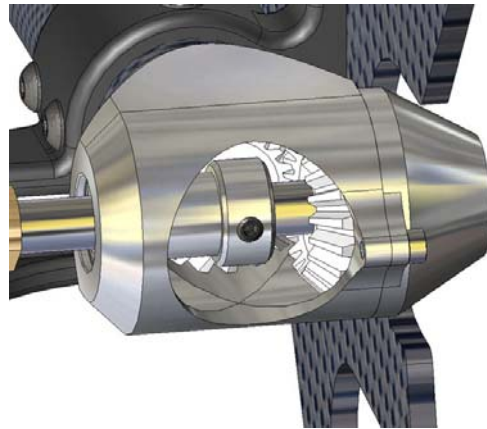

Tailcase inspection window.

There are three things that need to be assured for a correct mesh in the Aurora: Flush alignment, No Play and Lubrication.

- 1) **Flush alignment:** Make sure that the gears are aligned so that the inner side of the teeth are in the same plane flush to each other at the point of contact.
- 2) **No Play:** Make sure there is no play between the gears.
- 3) **Lubrication:** Make sure to lubricate the gears with a few drops of fuel before each flying day letting the alcohol evaporate leaving the fuel's oil as lubricant.

1) Flush Alignment:

In order to illustrate how to achieve it here's a couple of pictures of gears aligned incorrectly followed by a couple of pictures of correctly aligned ones.

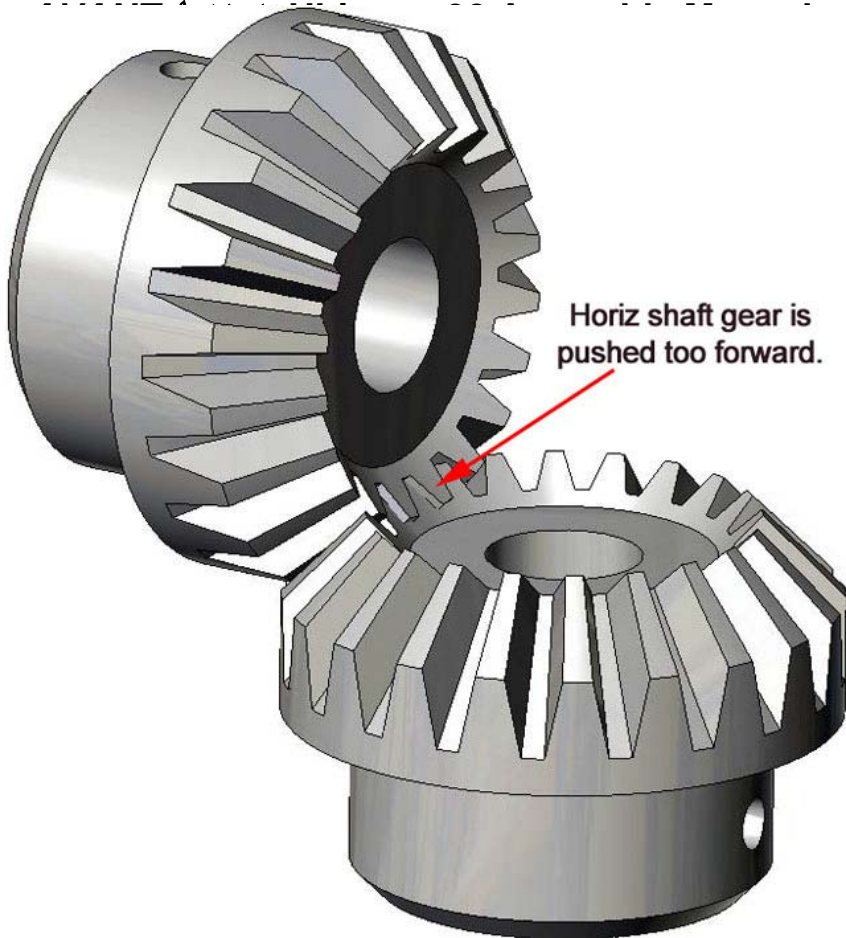

Wrong alignment case #2:
Bottom gear too forward

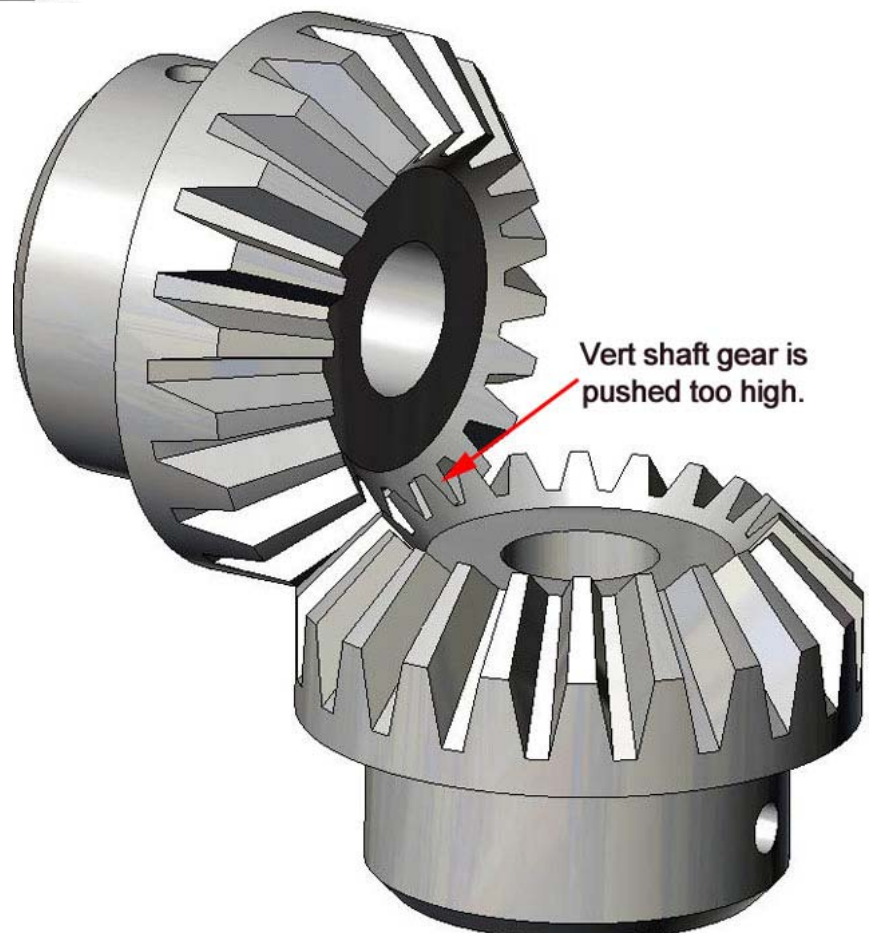

Note: Unless indicated otherwise all screws, balls and threads are installed with Blue Loctite



Flush alignment is easily achieved because the kit brings four sets of three bearings spacing washers of 0.1, 0.2 and 0.3mm thickness. Combining them you can get from 0.1mm to 0.6mm spacing (0.1), (0.2), (0.1+0.2), (0.3), (0.3+0.1), (0.3+0.2), (0.3+0.2+0.1). In order to align them flush you simply select thinner washer shims for the one that's too forward or thicker for the one that's not forward enough.

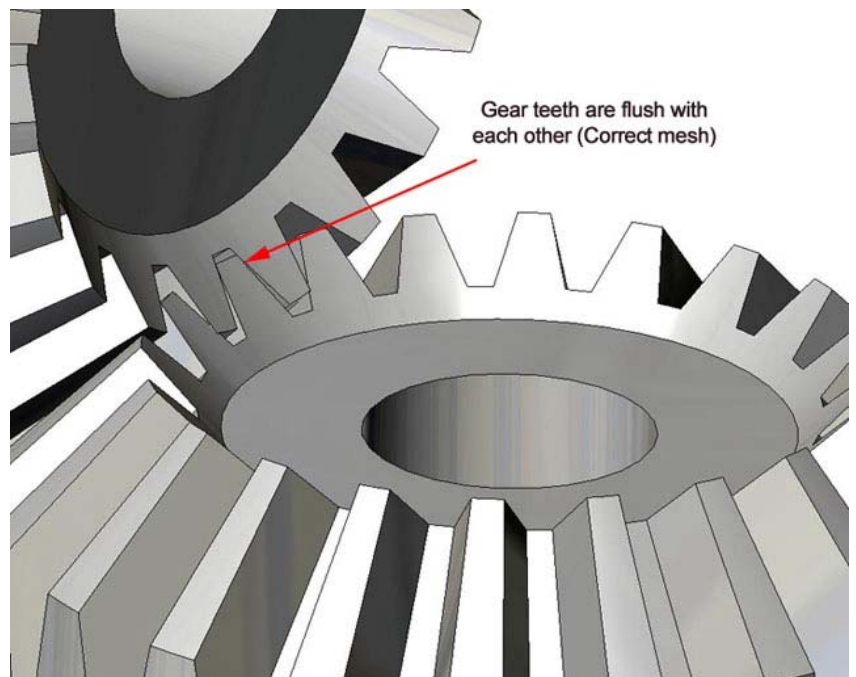

2) No Play:

The second and very important thing to make sure you have is that there is absolutely no play between the gears.

In order to make sure that there is no play between the gears hold one of the shaft firmly while trying to rotate the other one back and forth. There should be no movement on the gear. If there is movement simply increase the thickness on BOTH shafts the SAME amount so that the flush alignment from step 1 is not lost and try again.

Once set as described it'll take a few flights for the gears to set and break in.

3) Lubrication:

The same oil that will be left as residue from your flight session is used as lubricant. At the beginning of the flight day drop a few drops of fuel rotate the main rotor a few turns and let the alcohol evaporate for a couple of minutes leaving the oil residue for lubrication.

Remember the three steps:

- 1) **Flush alignment**
- 2) **No Play**
- 3) **Lubrication**

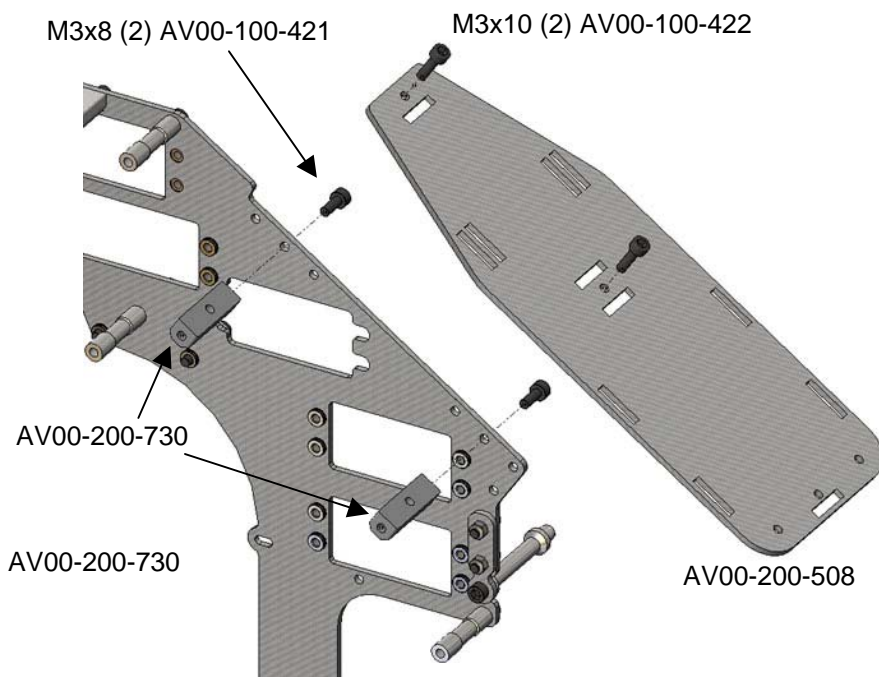
Bag #5: Battery / Radio Plate

Install battery blocks on the frames and then the battery/radio plate on them.

Note: Unless indicated otherwise all screws, balls and threads are installed with Blue Loctite

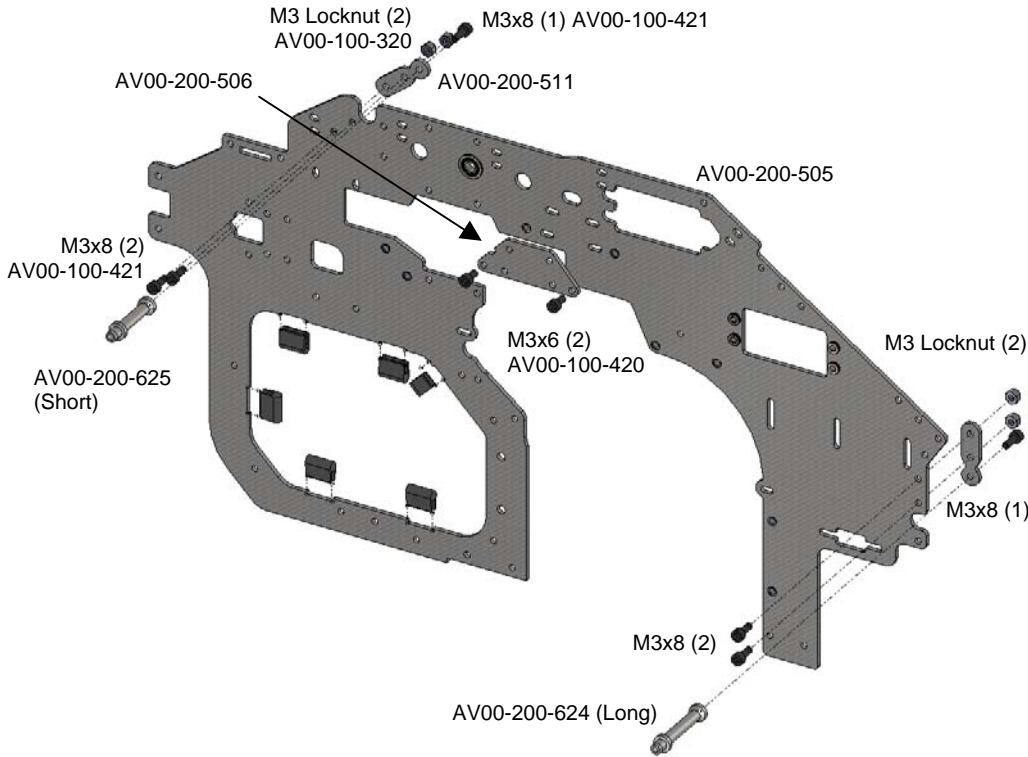

Bag #6: Right Frame, frame bellcrank and Tail boom clamp.

Install the sacrificial tabs and canopy mount posts as previously done in the left frame as well as the gear ratio plate as shown in the picture. Make sure the plate's notch is facing back toward the rear of the helicopter. Install the tank rubber mounts the same way as explained before on step 01.

Install the right frame onto the left side assembly as shown below.

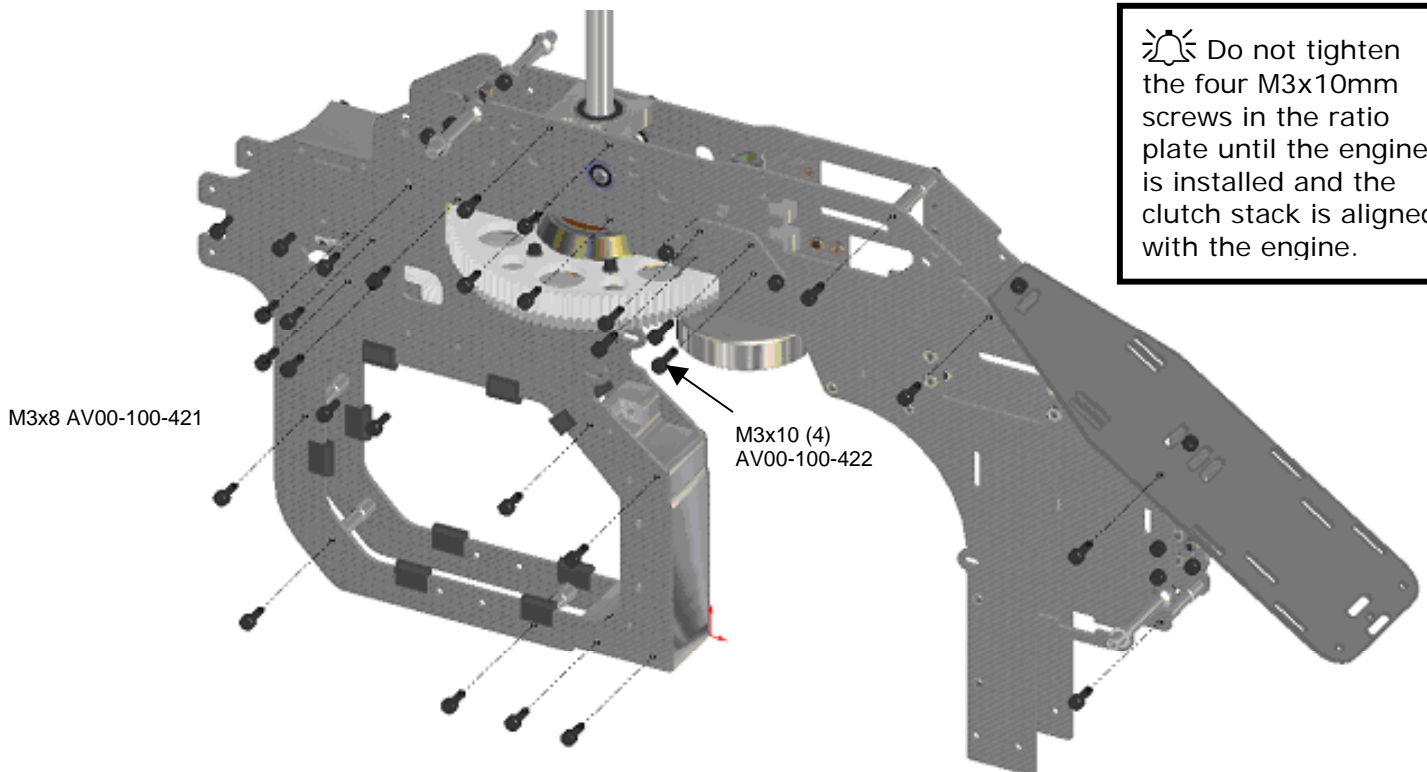

 Do not tighten the four M3x10mm screws in the ratio plate until the engine is installed and the clutch stack is aligned with the engine.

Note: Unless indicated otherwise all screws, balls and threads are installed with Blue Loctite

Install the boom clamps with the through bolts as shown. Do not tighten them until the boom is installed.

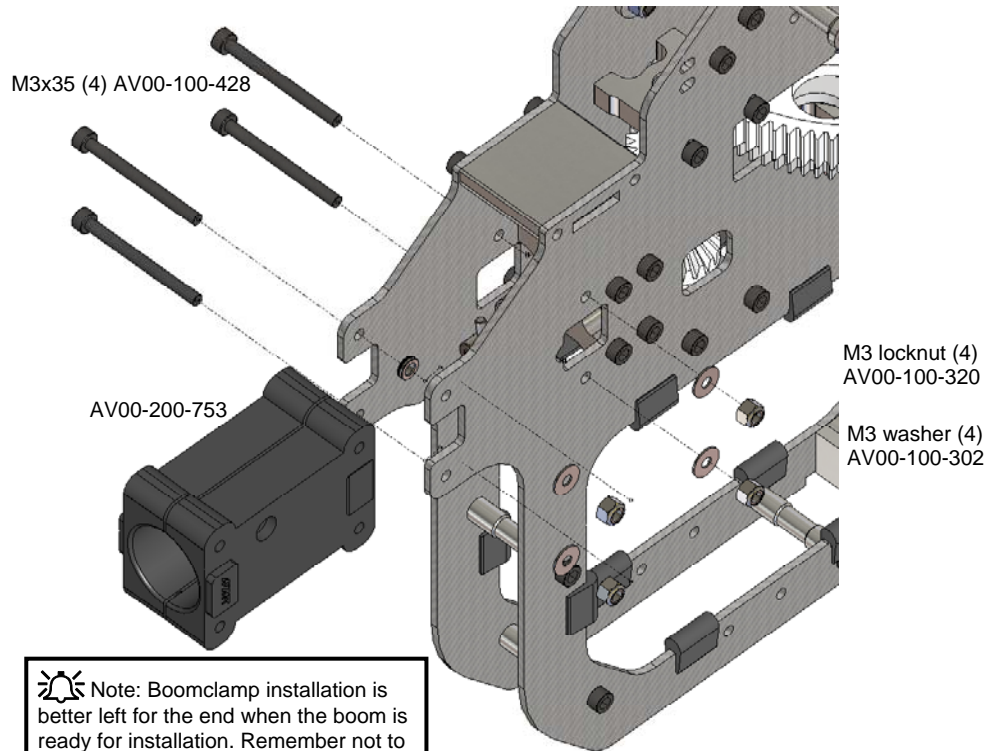

Assemble the tail frame bellcrank as shown.



 Note: Boomclamp installation is better left for the end when the boom is ready for installation. Remember not to tighten the clamps excessively or you could crack the carbon boom.

 Start the thread by using an M2 screw from the bag that contains the tailcase. Use Blue Loctite in the screw. Apply the same method for all M2 threads that go into plastic

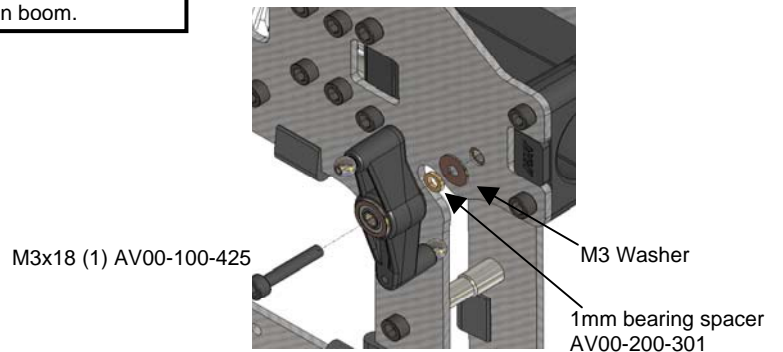

Bag #7: CCPM System and Swashplate

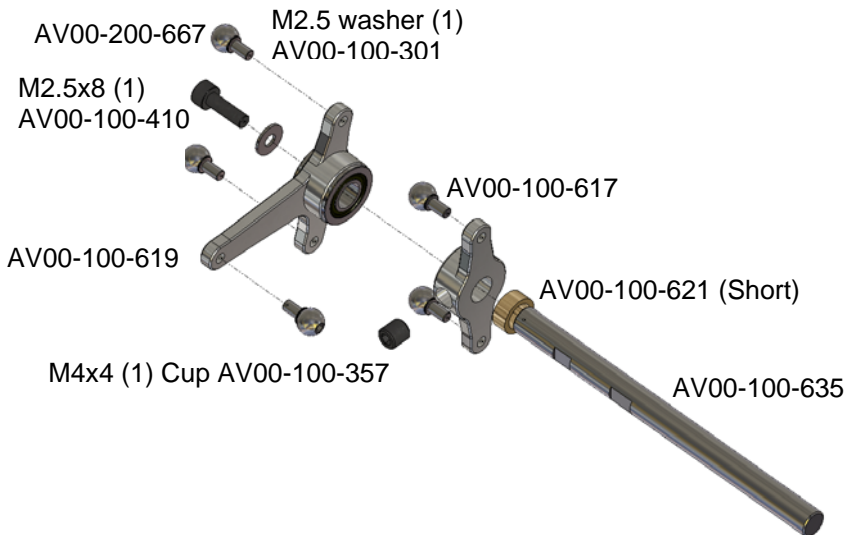

Note: Unless indicated otherwise all screws, balls and threads are installed with Blue Loctite

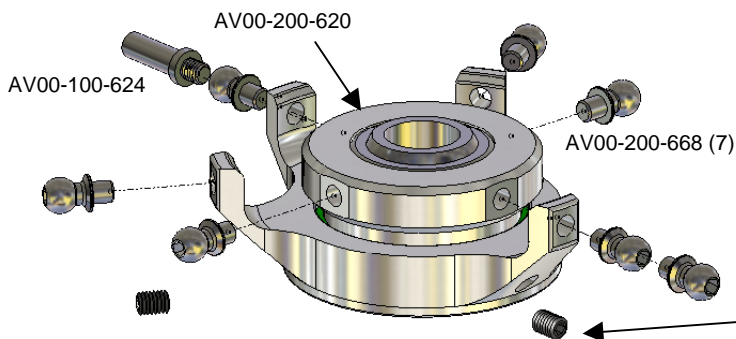
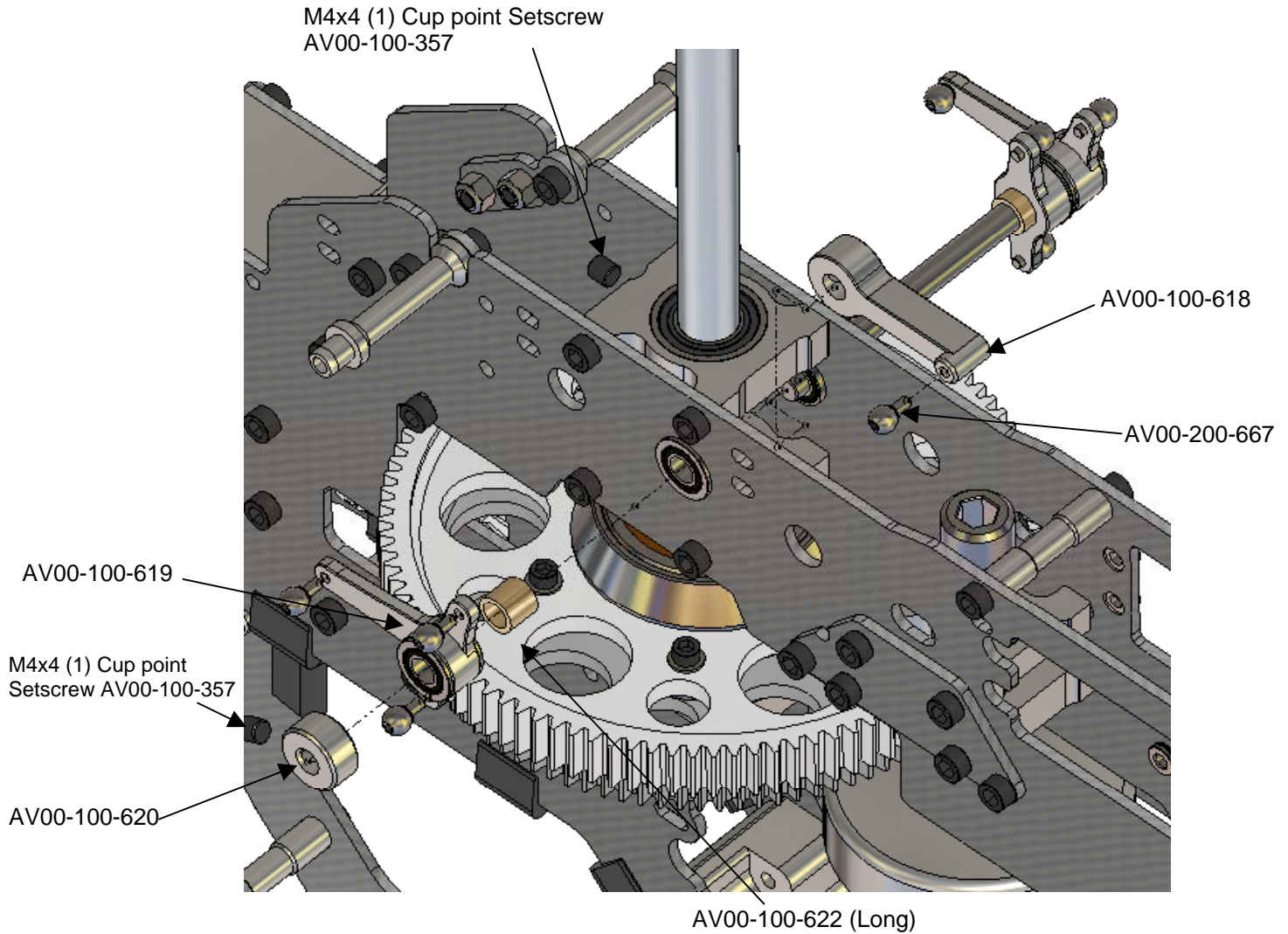

Install the seven balls and the guide pin on the pre-assembled swashplate as shown.

 M3x4 (3) AV00-100-350 Setscrew
Install three into the swashplate and don't over tighten them. Tighten them as needed to eliminate play as the bearing wears with use.

Note: Unless indicated otherwise all screws, balls and threads are installed with Blue Loctite

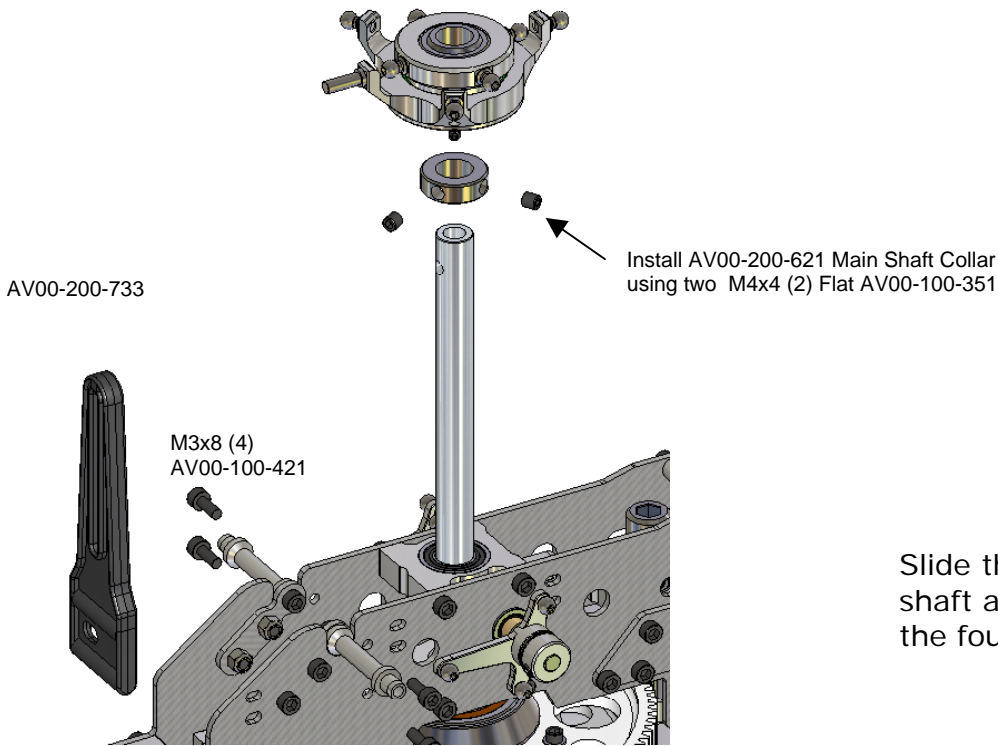

Slide the Swashplate onto the main shaft and install the CCPM guide with the four screws as shown.

Bag #8: Fan hub, Fan, Clutch and motor mount sides

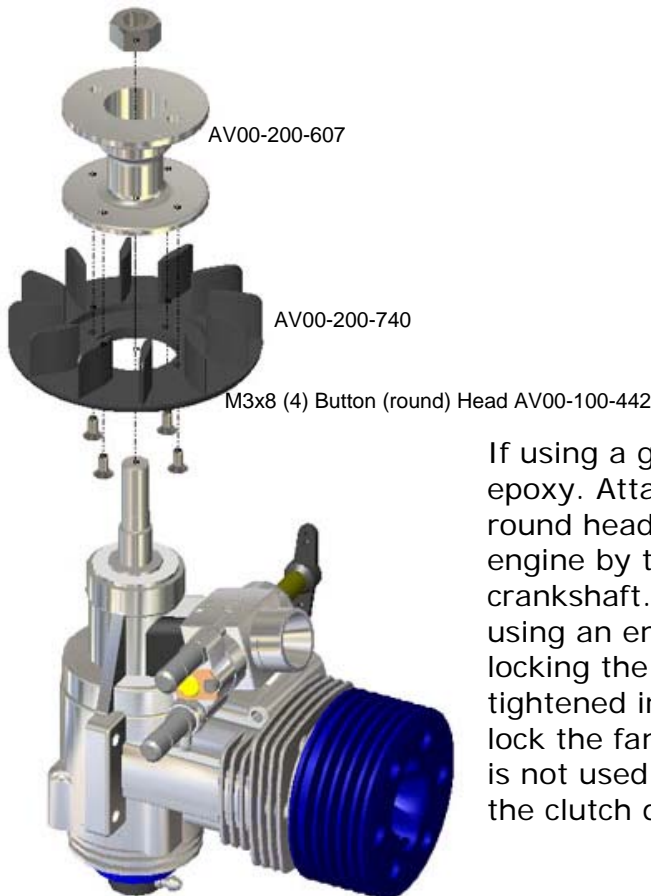

If using a governor install the magnet into the fan with epoxy. Attach the fan to the fan hub with the four round head screws then install the fan hub into the engine by tightening the fan into the threaded crankshaft. Lock the engine crankshaft in place by using an engine lock from the back of the engine and locking the piston rod in place. Once the fan is tightened in place use the engine's washer and nut to lock the fan in place. In most cases the engine washer is not used. If you use the engine washer make sure the clutch doesn't bind against the clutch bell.

Note: Unless indicated otherwise all screws, balls and threads are installed with Blue Loctite

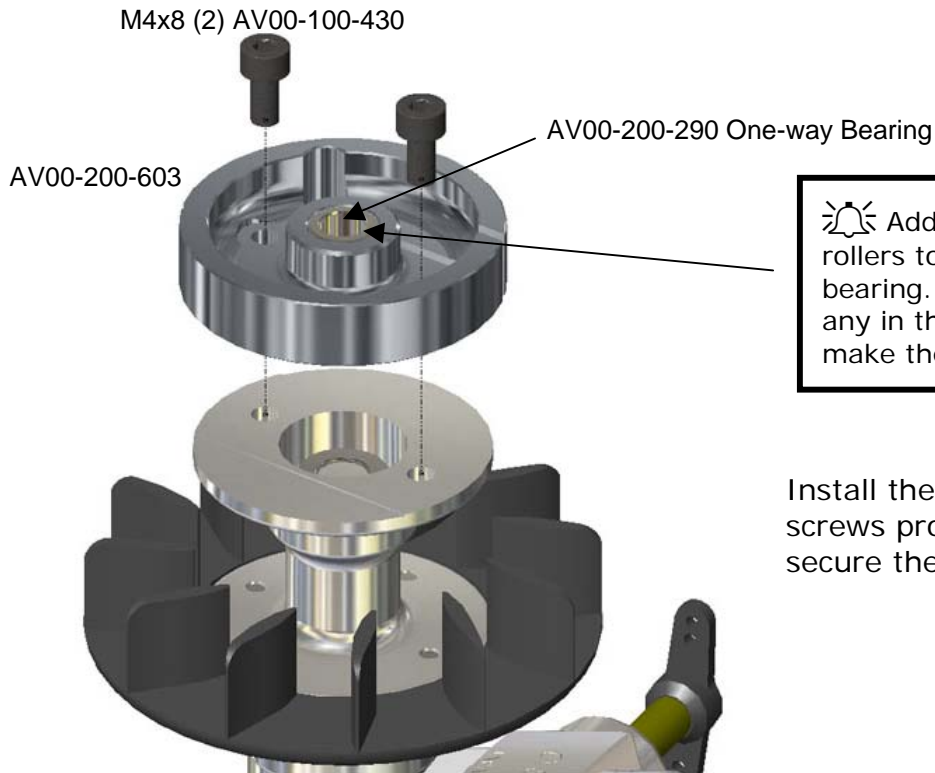

Install the clutch using the two M4 screws provided. Use blue Loctite to secure them.

Insert the engine in place by making the starter shaft fit into the clutch one-way bearing. Use blue Loctite to install the four M4 screws provided that hold the motor mount sides in place. Use blue Loctite to install the four M4 screws provided that hold the engine in place. If using a governor also install the sensor plate. Use the location of the sensor plate to mark the location in the fan shroud so an opening can be made in the fan shroud to allow for the sensor to clear.

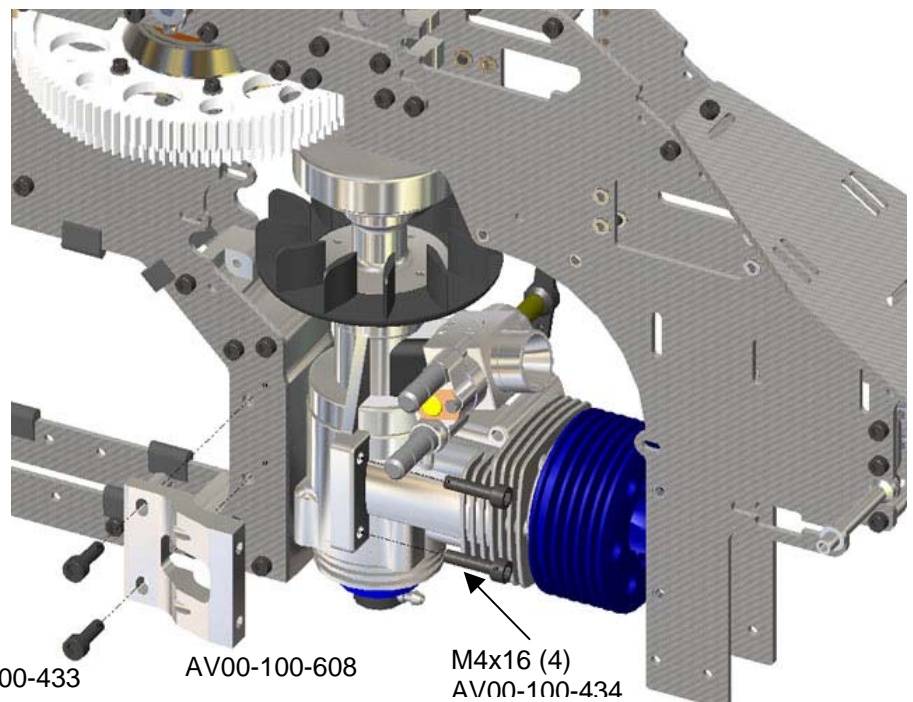

Note: Unless indicated otherwise all screws, balls and threads are installed with Blue Loctite

Bag #9: Fan shroud installation

 Now that the engine is in place rotate the starter shaft and make sure it's aligned with the one-way bearing. Tighten the eight bearing block screws accordingly. And the engine and motor mount sides bolts.

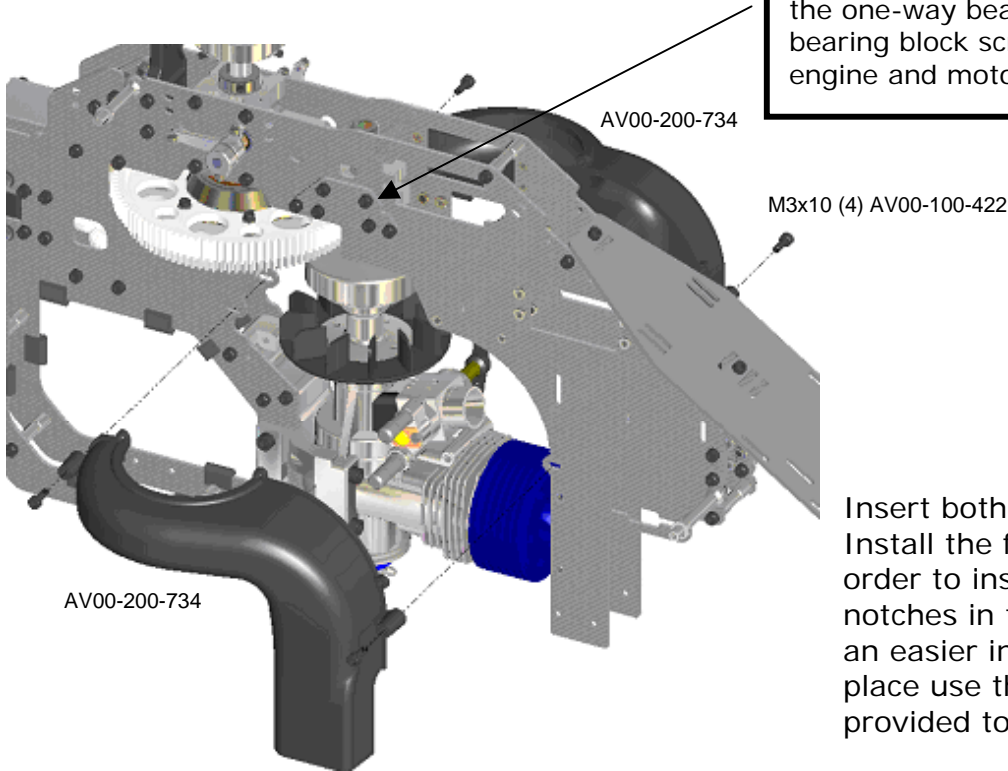

Insert both fan shroud sides in place. Install the fan shrouds in place. In order to insert them in place there are notches in the back side that allow for an easier insertion. Once located in place use the four M3x10 screws provided to secure them in place.

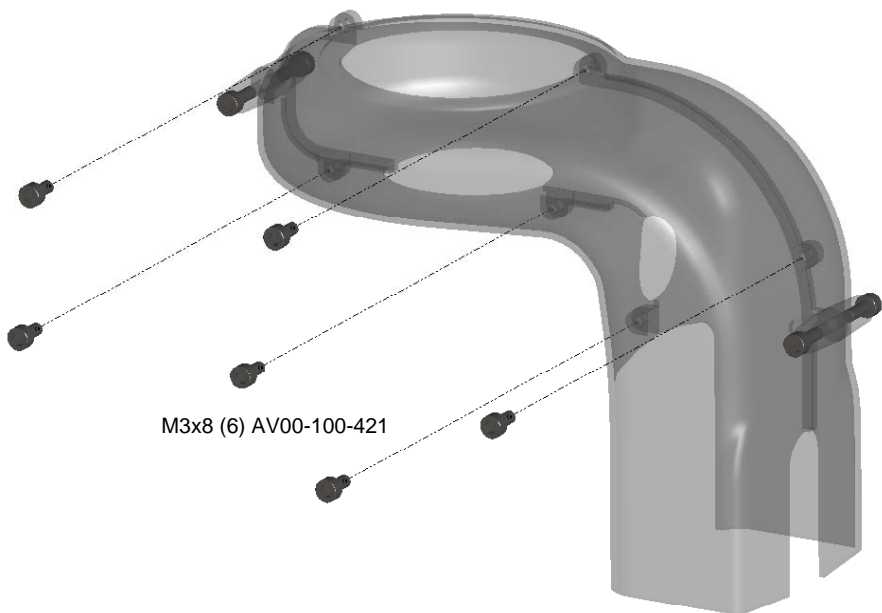

Join the two fan shroud halves using the six M3x8 screws provided.

Bag #10: Landing gear installation

Insert the landing gear skids into the landing gear struts as shown. Use the frames as a reference to space them approximately where they go. Insert the four M3x5 setscrews but don't tighten them completely until the assembly is installed on the helicopter.

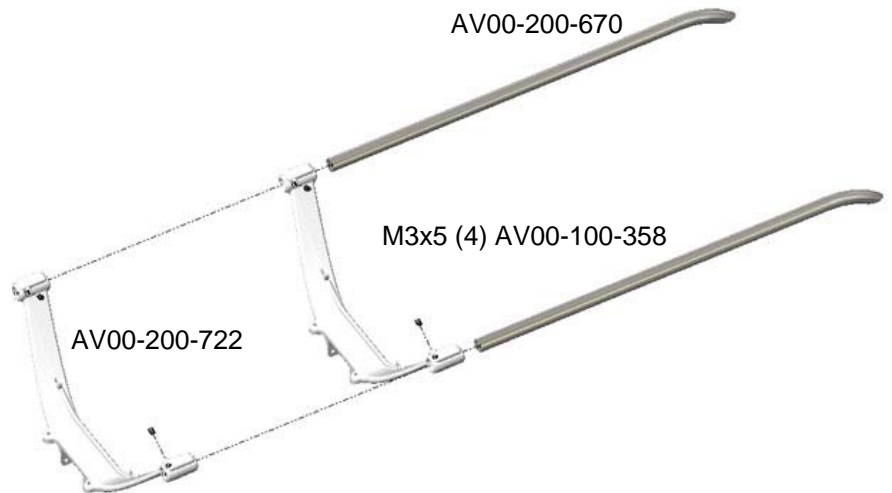

M3 washer (4)
AV00-100-302

M3x10 (4)
AV00-100-422

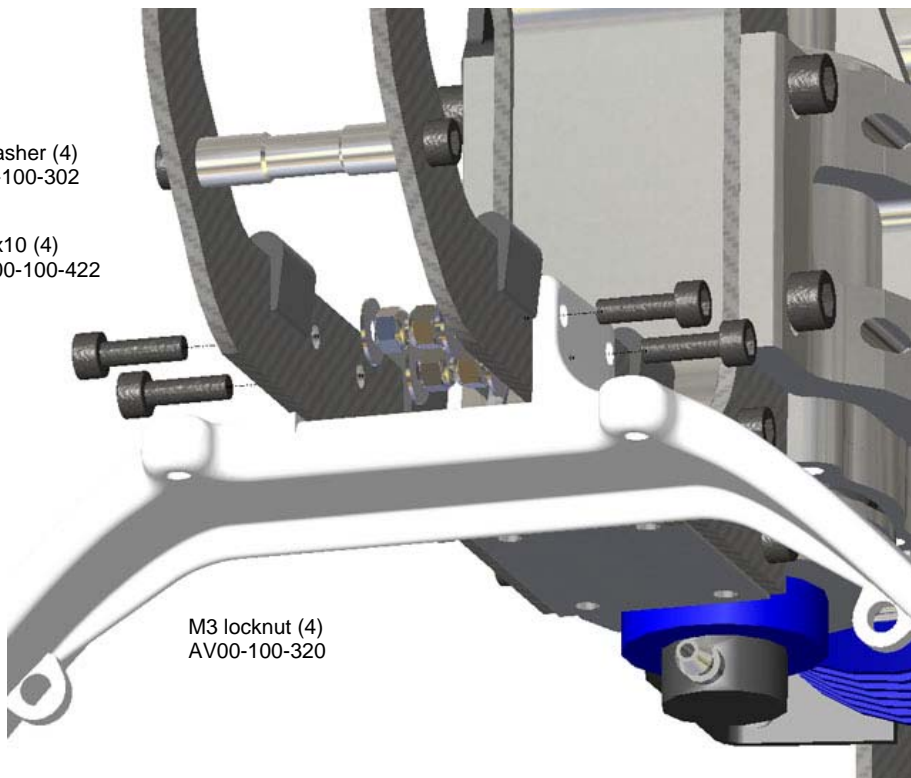

Using the provided hardware install the back landing gear struts on the frames as shown. You might need to squeeze the frames inward to make the struts fit.

Note: Unless indicated otherwise all screws, balls and threads are installed with Blue Loctite

Adjust the separation of the landing gear struts to make them match the holes on the frames. Using the provided hardware install the front landing gear strut on the frames as shown.

M3x10 (4) AV00-100-422

M3 washer (4) AV00-100-302

M3 locknut (4) AV00-100-320

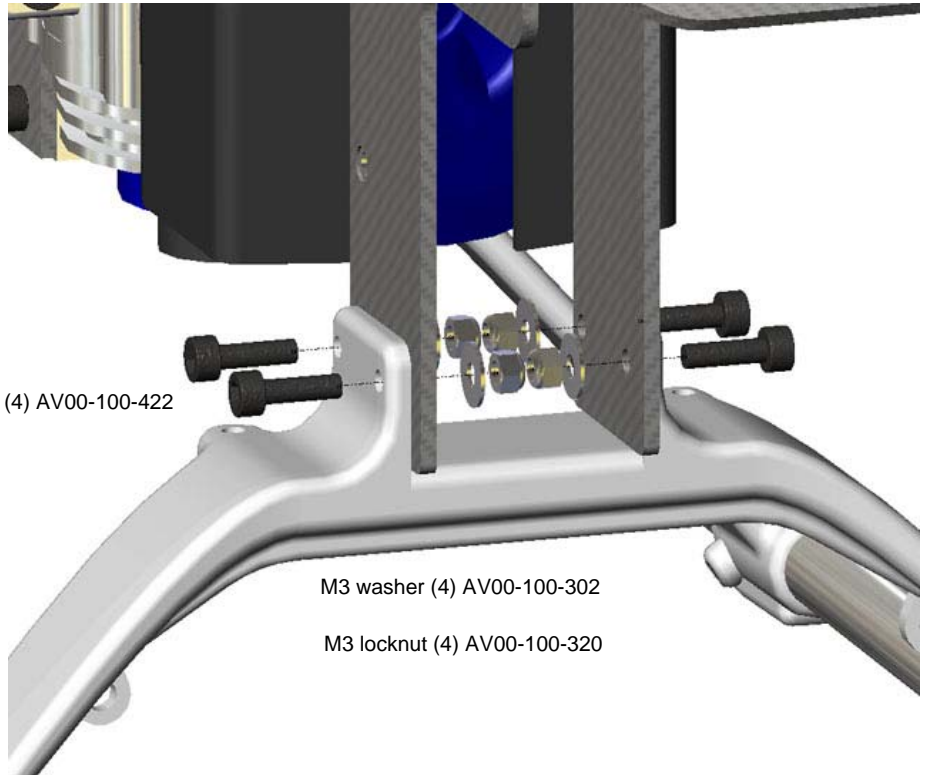

Tank Stopper assembly:

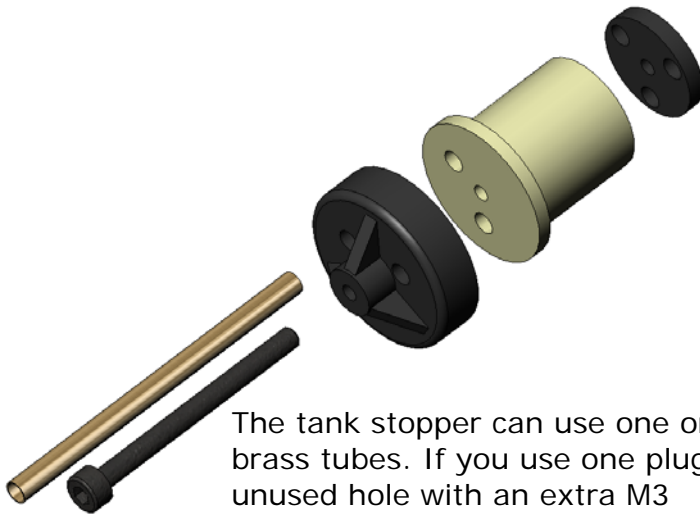

The tank stopper can use one or two brass tubes. If you use one plug the unused hole with an extra M3 setscrew and make a 1/8-inch hole on the tank top and screw in the fitting provided together with the small o-ring.

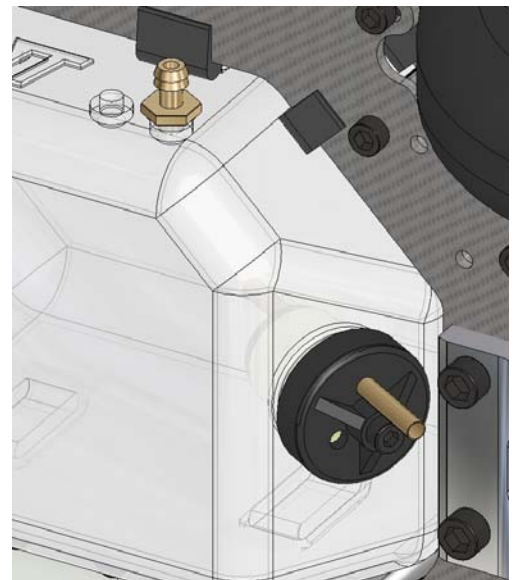

Note: Unless indicated otherwise all screws, balls and threads are installed with Blue Loctite

Bag #11: Bottom plate and right side stiffener.

Install the bottom plate with the four screws as shown. Once the back screws are installed install the front side with the hardware provided. Once installed it should look like the picture below.

Correct installation

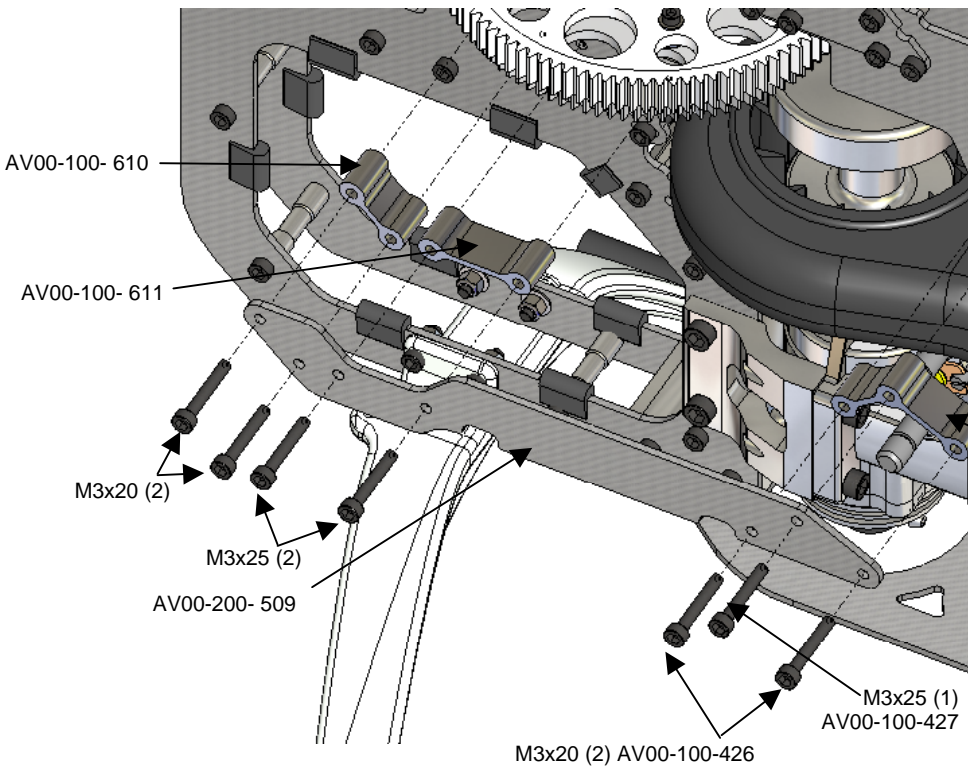
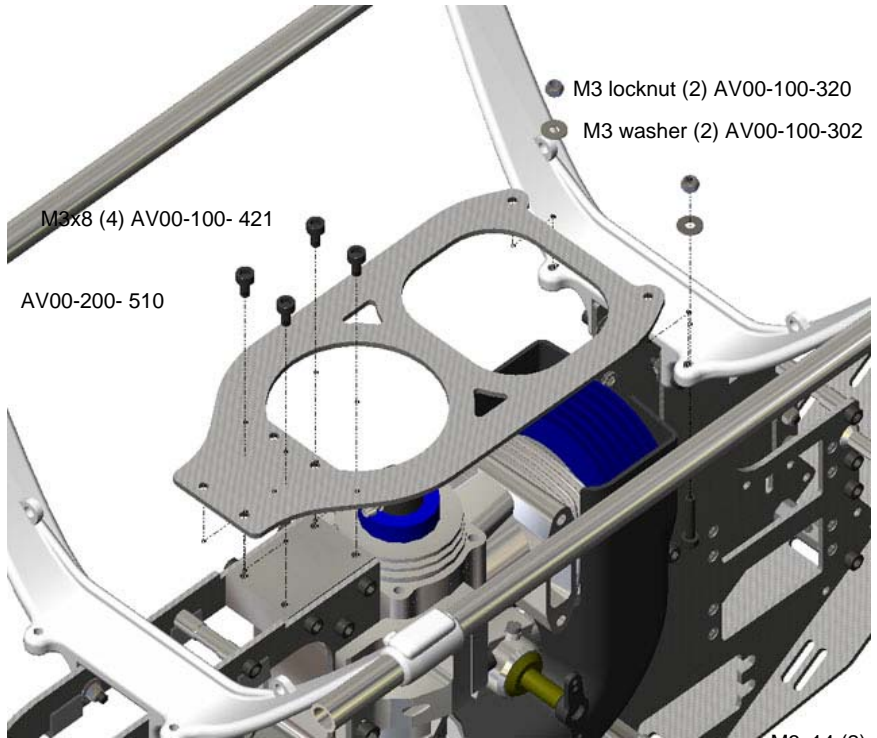
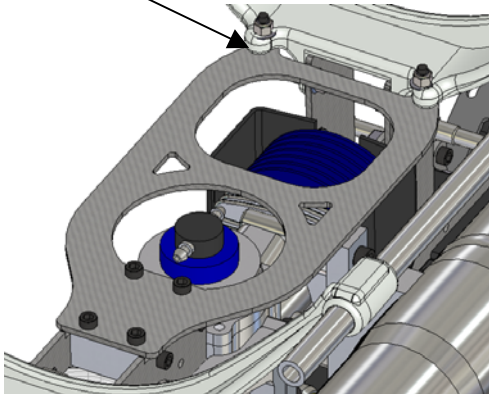

Proceed now to install the side stiffener plate by using the three spacers and the seven screws provided.

AV00-100-612

Note: Unless indicated otherwise all screws, balls and threads are installed with Blue Loctite

Bag #12: Fuel Tank hardware preparation

Install the previously assembled fuel tank by pushing the top and bottom effectively squeezing the tank to make it fit in between the frame's rubber edges.

 Remember than in order to access the main shaft setscrew that holds the main shaft pin you need to remove the tank and access the setscrew from the bottom side.

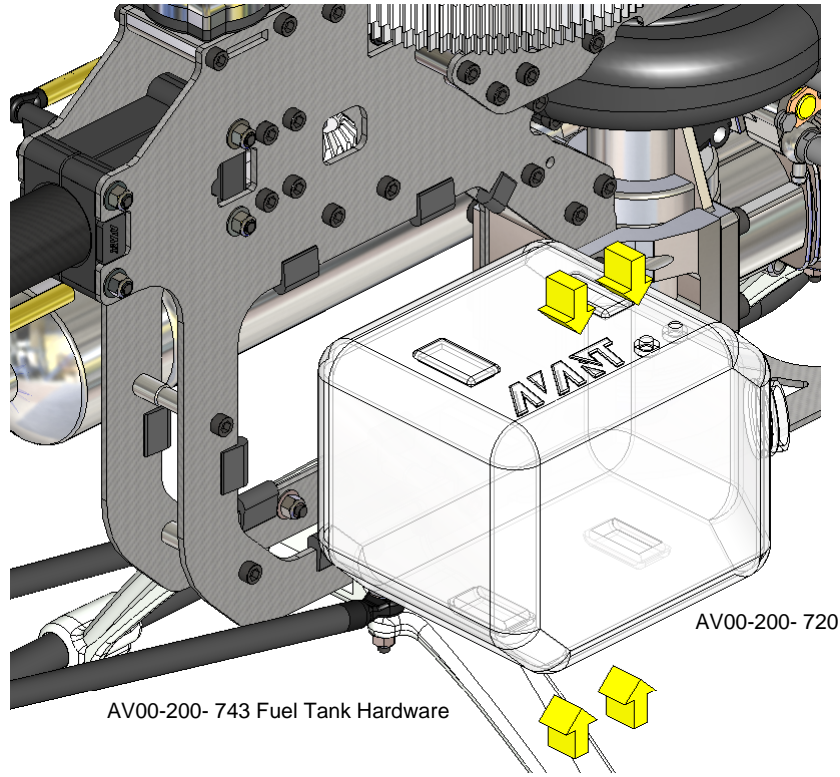

Bag #13: Torque Tube Assembly

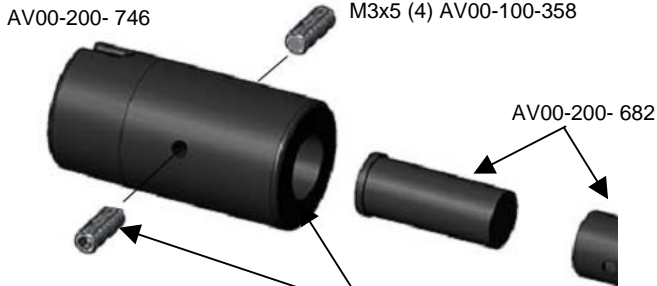

 The Black anodized aluminum tube is made out of a soft alloy that's more resistant to fatigue breaks. Being that the case it's also easier to bend unintentionally. Be careful when handling the torque tube and use oil or grease when inserting it into the boom.

 Insert the m3x5mm setscrews and tighten them only until the head is flush with the connector's surface. Apply thin CA between the tube and the connector after the setscrews are tightened.

Insert the bearing into the shell and then apply CA glue to the edge and quickly slide into the shell.

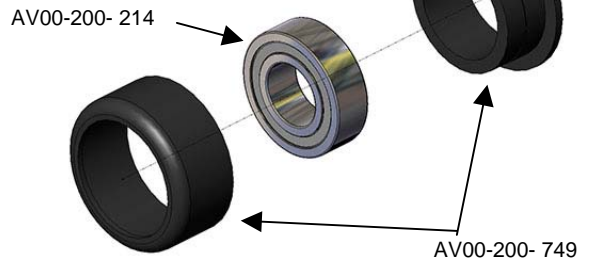

Install an AV00-200- 747 Soft O-Ring for Torque Tube in the groove.

To secure the TT bearings apply a very small amount of thick CA glue to the TT at the indicated distance and slide onto the CA glue slowly while rotating the tube to check for misalignment. Do not use too much glue or it could get into the bearing while sliding it into place ruining it. Do not change the distance trying to make it equally spaced the distances are correct as they are.



Note: Unless indicated otherwise all screws, balls and threads are installed with Blue Loctite

Bag #14: Tail assembly.

 When tightening the 6mm shaft collar pull the shaft slightly outward while pushing the collar inward to eliminate any play.



Torque Tube Input Shaft, case and gear

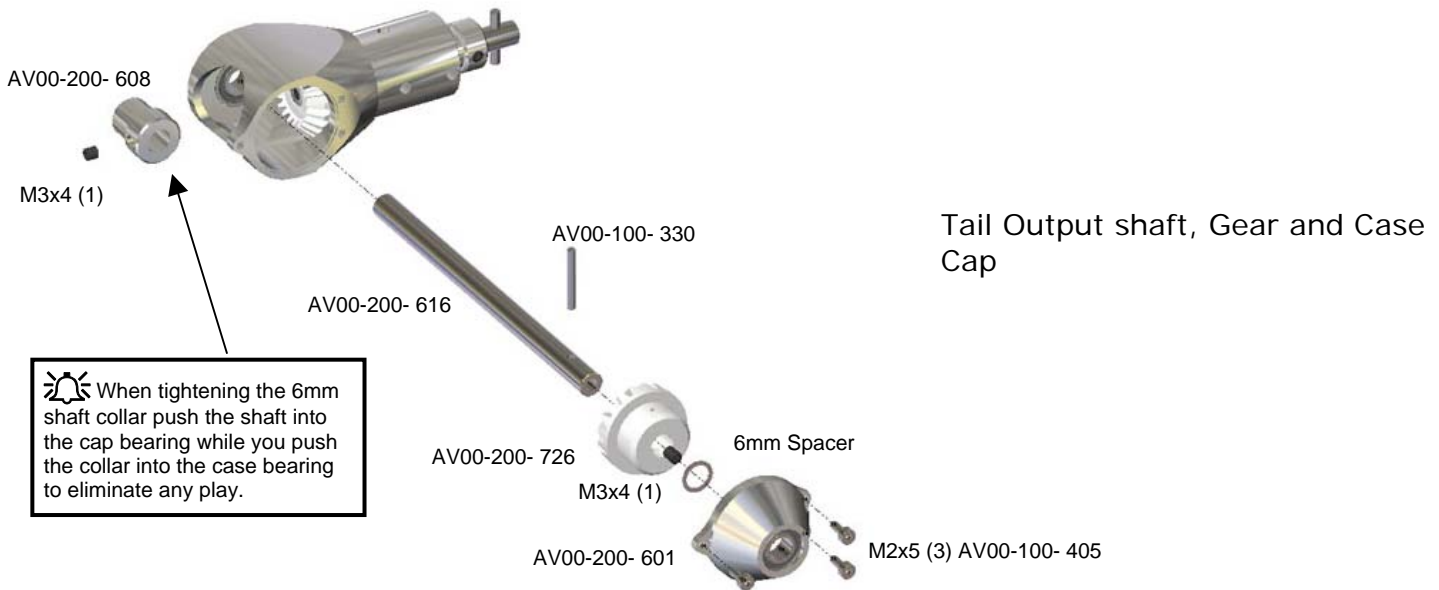

 When tightening the 6mm shaft collar push the shaft into the cap bearing while you push the collar into the case bearing to eliminate any play.

Tail Output shaft, Gear and Case Cap

Note: Unless indicated otherwise all screws, balls and threads are installed with Blue Loctite

 When installing the tail yoke into the brass sleeve start by pushing it into the sleeve. Once the smaller ID area is reached then continue by screwing it in. If you start by screwing it in you might prevent it from aligning correctly with the sleeve.

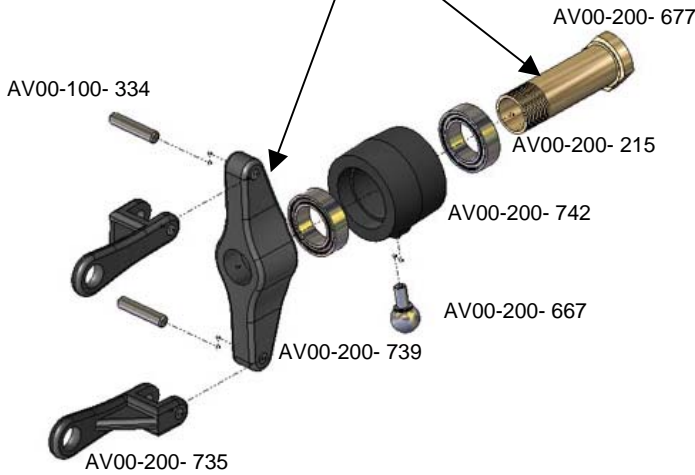

Tail Slider Assembly.

Tail Hub and Grips.

 The Tailgrips are designed with an amount of pre-loading for the bearings. This eliminates any play between the bearing and the bladegrip. When tightening the 2.5mm button head screws make sure you keep the grip halves pressed against each other. At the end of the tightening make sure you don't strip the plastic threads by tightening the screws too hard.

 The thrust bearings have two different inner diameter race holes. Use the larger one inside and the smaller one outside on the screw side.

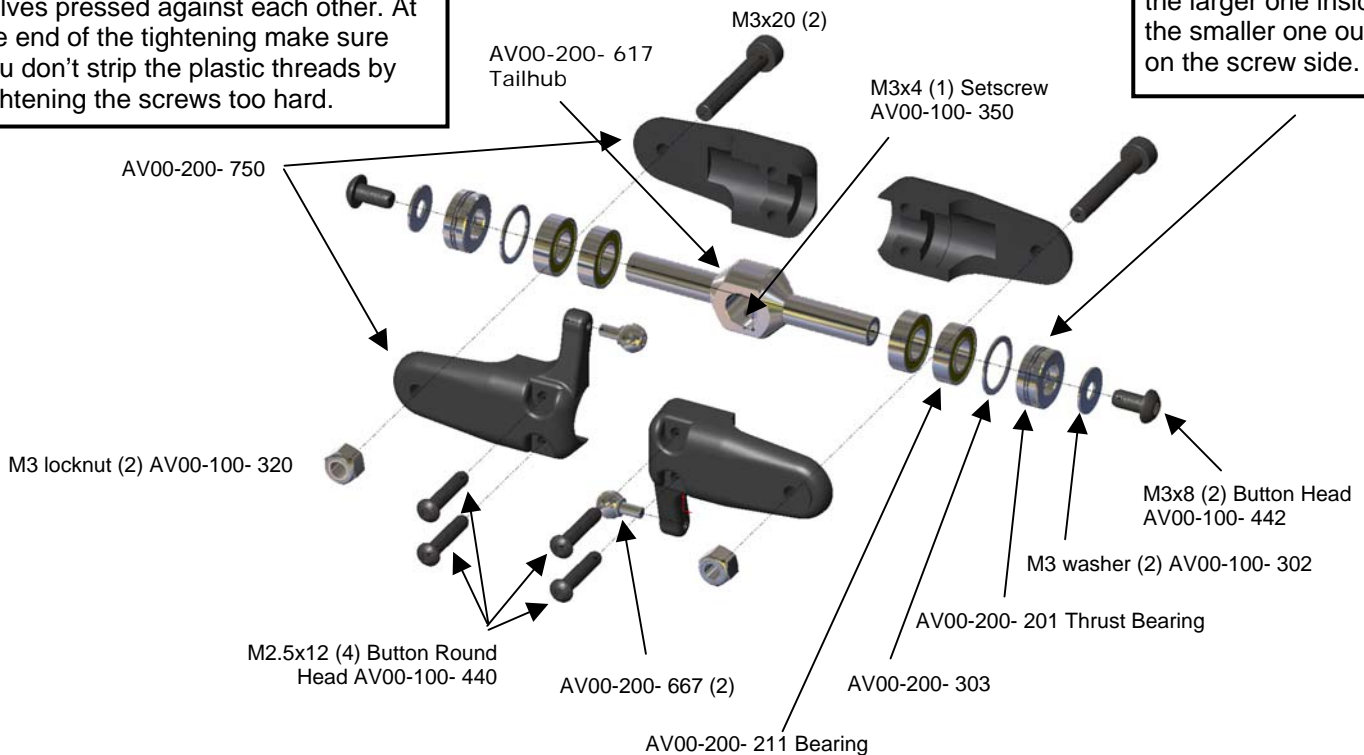

Note: Unless indicated otherwise all screws, balls and threads are installed with Blue Loctite

Tail L Bellcrank.

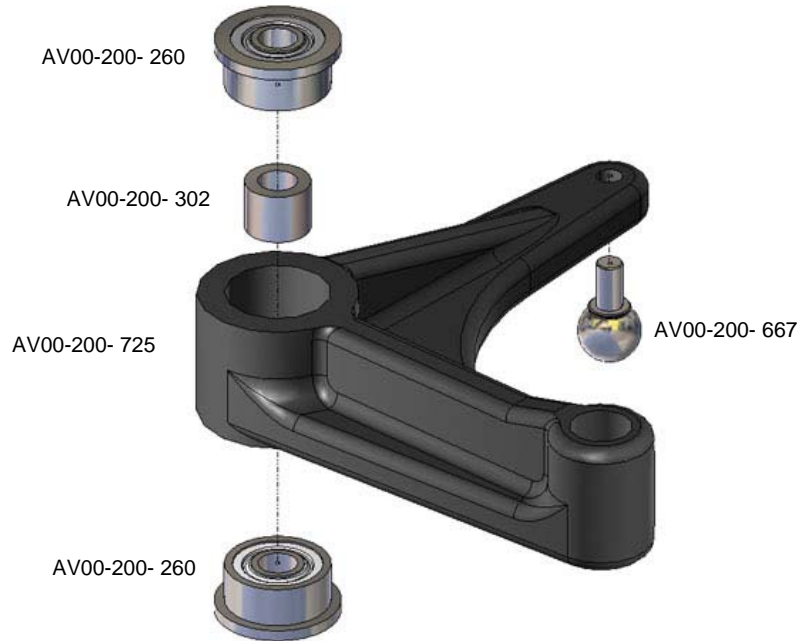

Fin and Tail Clamp Assembly.

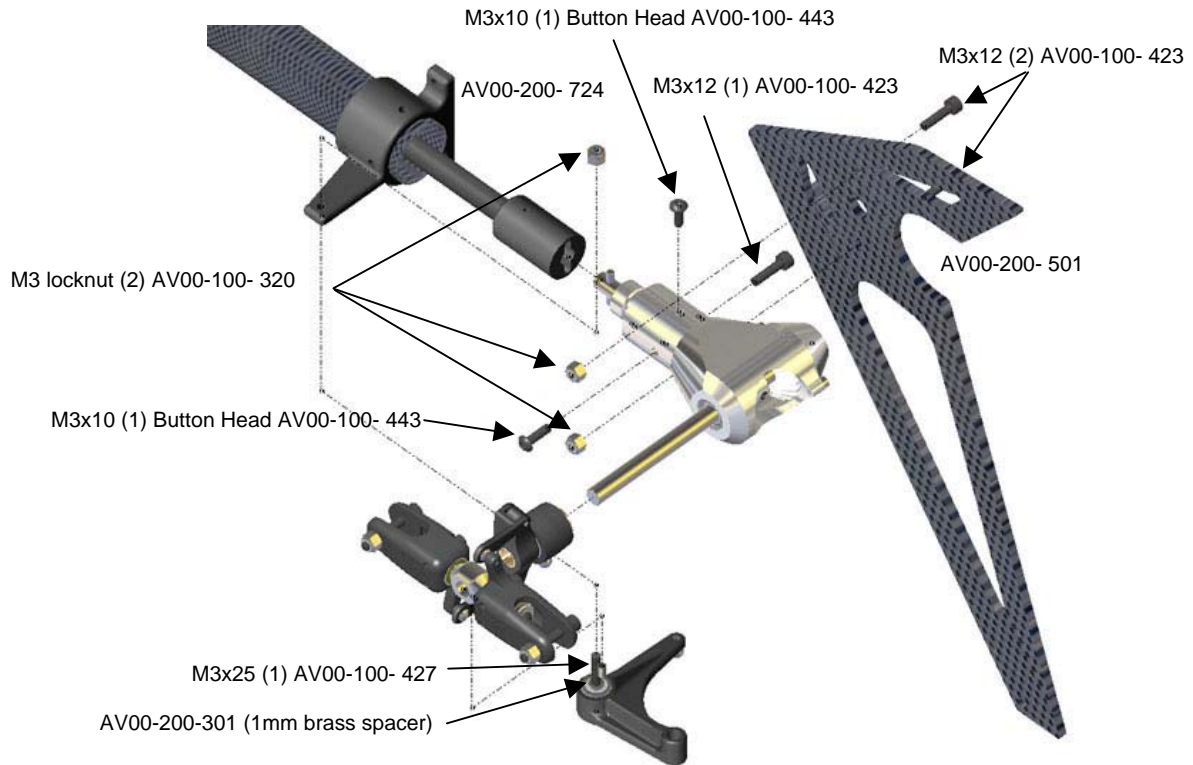

Note: Unless indicated otherwise all screws, balls and threads are installed with Blue Loctite

Bag # 15: Boom Supports and Horizontal Fin.

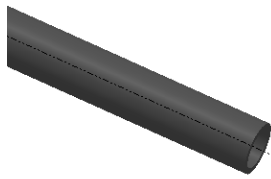

Clean the inside thoroughly with alcohol or acetone and use epoxy of at least 30-minute duration and let it cure before use. Make sure both ends are aligned with the flat faces parallel to each other

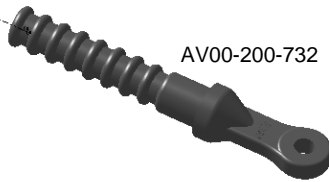

AV00-200-732

Boom Support Ends

Front support ends installation

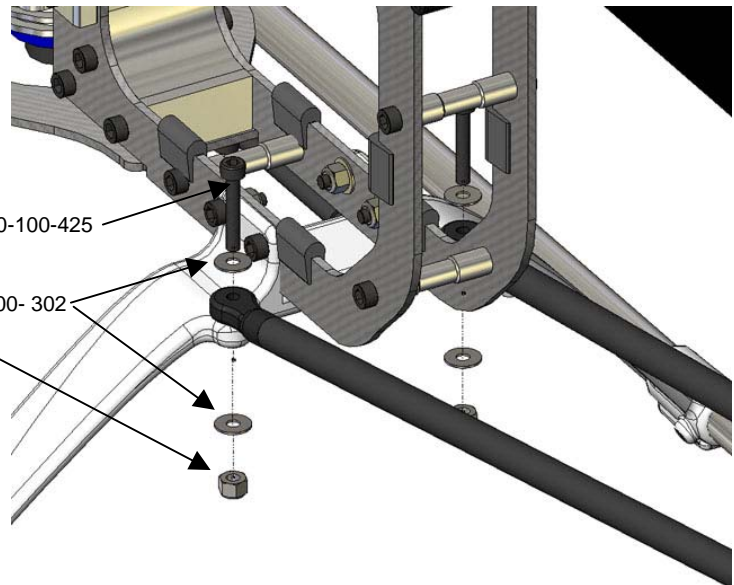

M3x18 (2) AV00-100-425

M3 washer (4) AV00-100-302

M3 locknut (2) AV00-100-320

M3 locknut (2) AV00-100-320

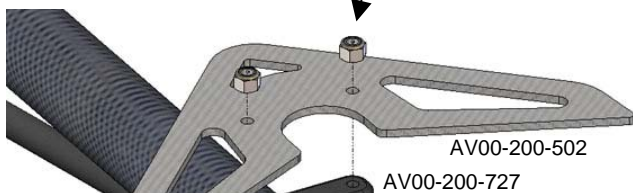

AV00-200-502

AV00-200-727

M3 washer (4) AV00-100-302

M3x40 (2) AV00-100-429

Back support ends installation.



Make sure not to crack the boom from over tightening the horizontal fin clamp. It needs to be nice and tight or you might get vibrations.

Note: Unless indicated otherwise all screws, balls and threads are installed with Blue Loctite

Bag #16: Head assembly

Head Step 1)

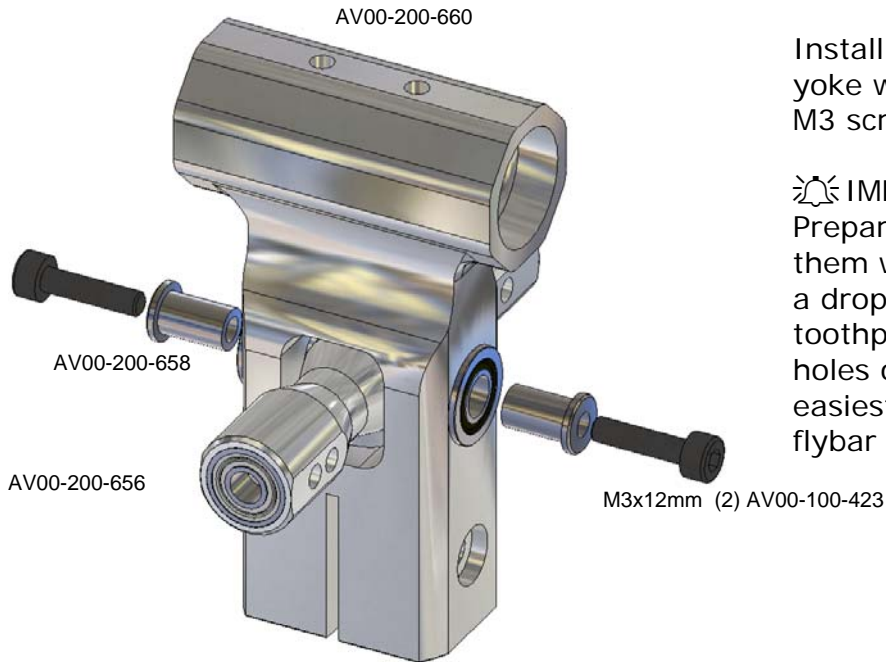

Install the flybar carrier inside the yoke with the spacers and 12mm M3 screws, read below first.

⚠ IMPORTANT Note:
Prepare both M3 bolts by cleaning them with rubbing alcohol. Apply a drop of red Loctite to a toothpick and insert in center holes of flybar carrier. This will be easiest to do before inserting flybar carrier into the yoke.

Head Step 2)

Install the flybar double balls using RED LOCTITE.

Center hole position is a good overall setting. Rotated flybar and using the hole closer to the yoke makes it faster (Less flybar ratio). Outer hole location makes it more stable (Higher flybar ratio as shown here).

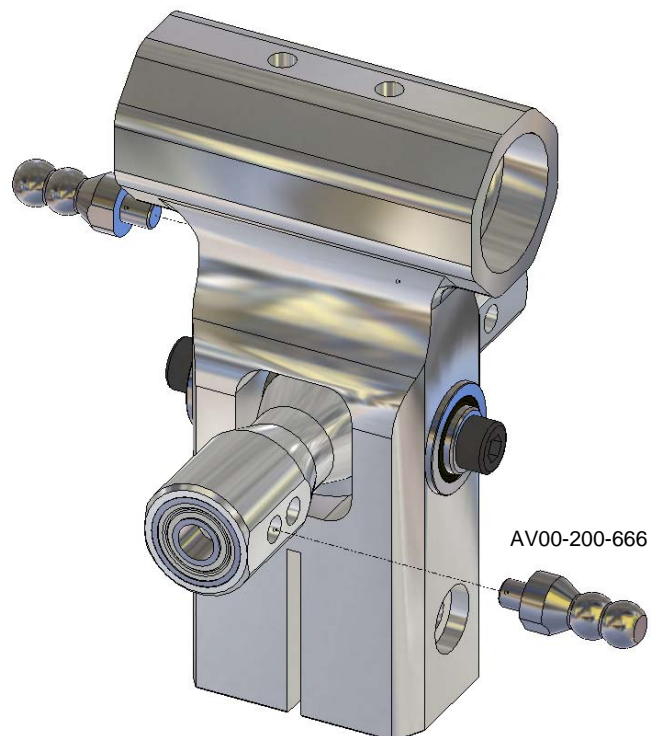

Note: Unless indicated otherwise all screws, balls and threads are installed with Blue Loctite

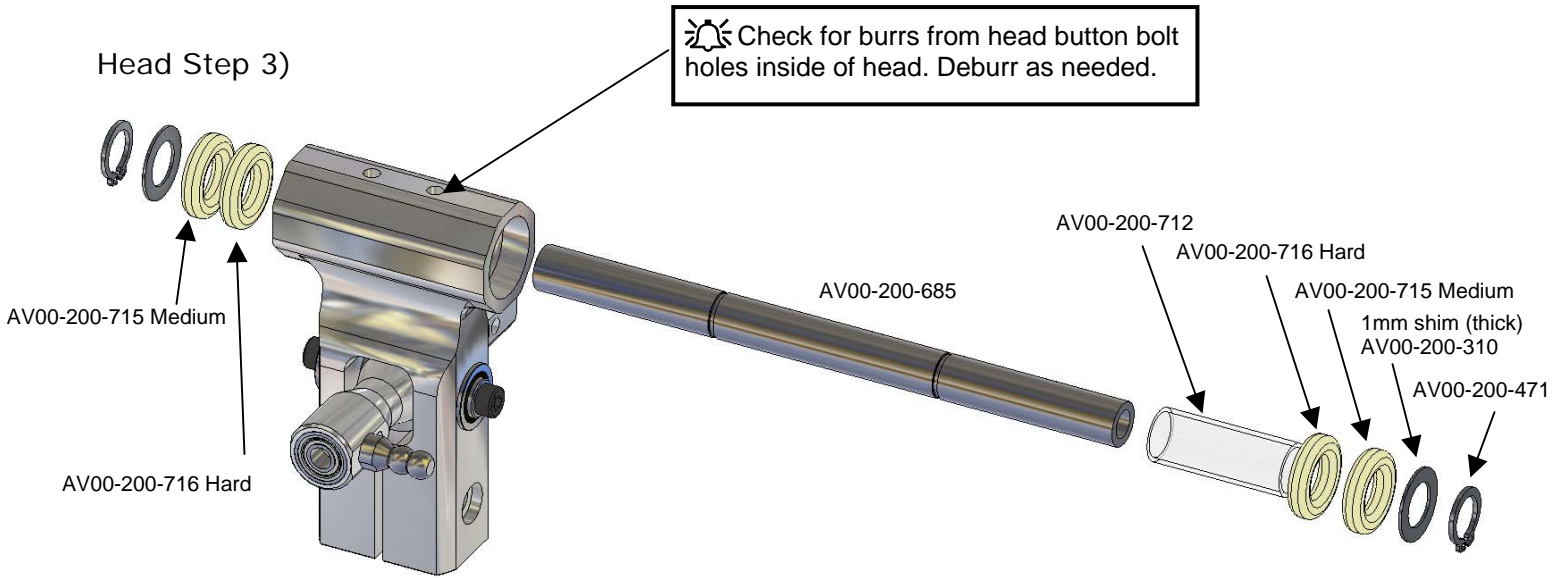

Slide the tubing up to the middle of the spindle, hemostats or [long needle nose pliers](#) work well for this. Applying a very thin coat of liquid soap to the head spindle will also make it slide on easier. Use the provided O-Rings and one 1mm shims held in place with a C-Clip, you will need to do this with external C-Clip ring pliers. Complete one side of the o-ring installation with shims and c-clip, then insert head spindle through one end of head yoke. Use soapy water by dissolving some hand soap into some water and wet the center dampener tube and the inside of the yoke and then insert the spindle with the dampening tube already installed in the center of it. Insert the remaining two o-rings from other side along with the one 1mm shim.

Slide the clip into the groove with your c-clip pliers. Use the provided brass tube tool together with the M5 washer and M5 screw to push the c-clip in place. Make sure you stop the moment the c-clip falls into place into the grove.

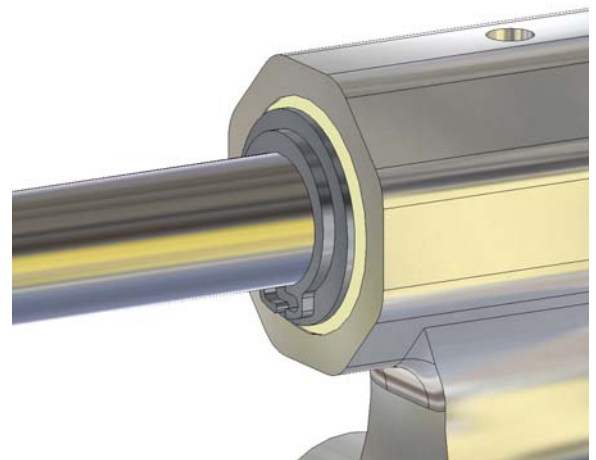

Note: Unless indicated otherwise all screws, balls and threads are installed with Blue Loctite

Head Step 4)

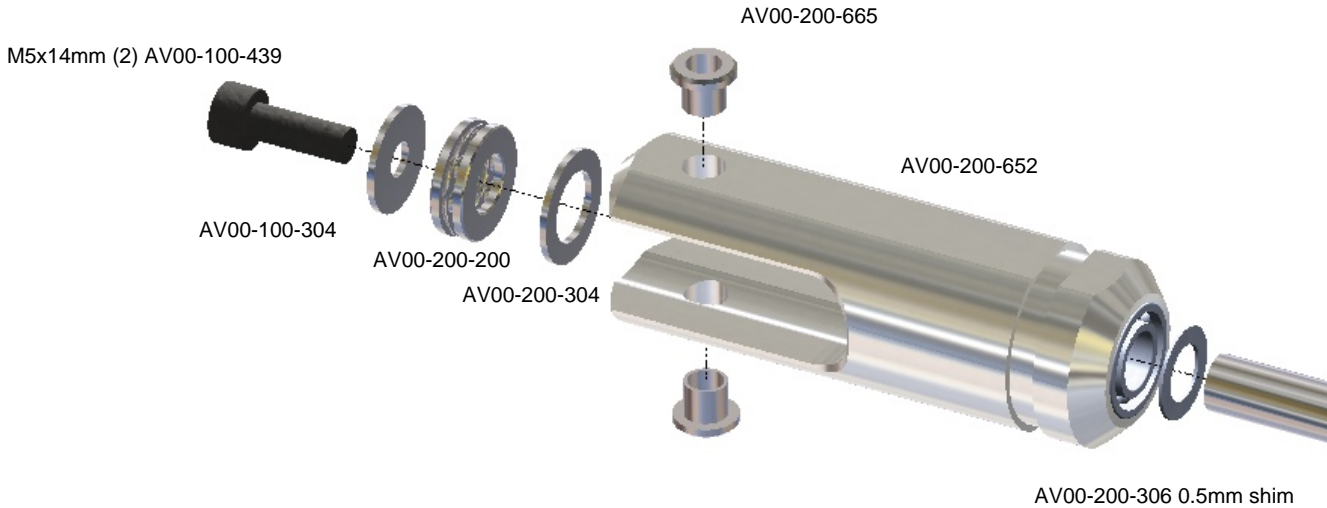

Use one of the 0.5mm shims on the inner side of the bladegrip.

Important note:

Grease both thrust bearing races and center before installation.

Install the provided 16x1x10 bearing "spacer" first.

Examine the supplied thrust bearing, one of the outer races will have a loose fit on the spindle and that will need to be installed first with the ball race facing out. Next you will need to insert the center part with cup side facing in. Finally you will insert the outer race which is a tighter fit on spindle with ball race facing in.

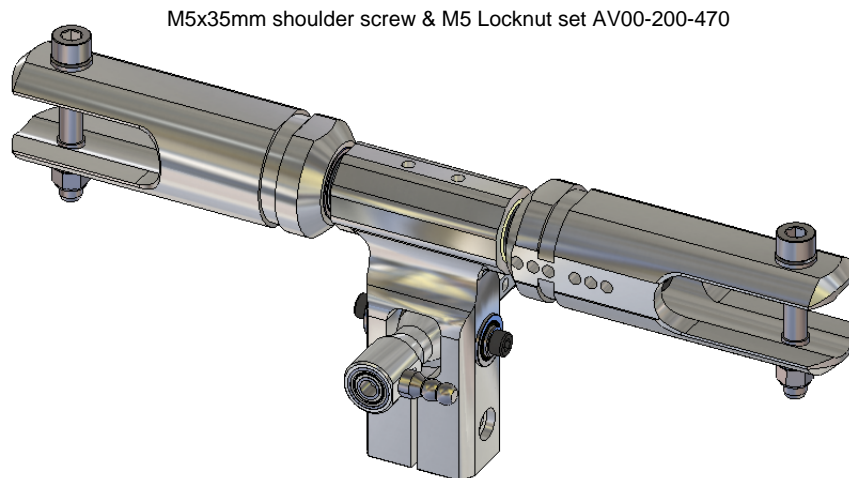

Repeat for the other side

Note: Unless indicated otherwise all screws, balls and threads are installed with Blue Loctite

Head Step 5)

Hole location names for the mixing arms

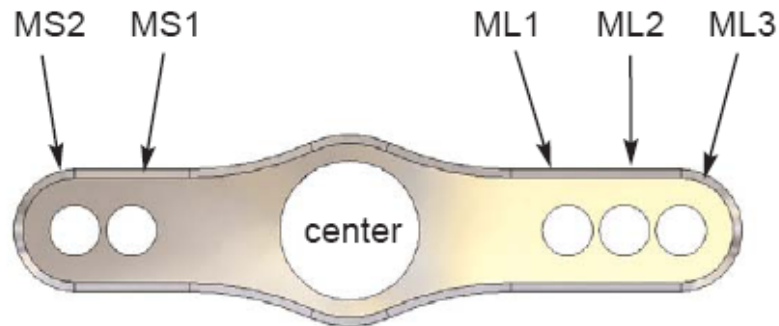

For the rod coming from the swashplate (left) using holes closer to the center make the head more active and away from center make the head more stable. For the rod from the flybar (right) using holes closer to the center make the head less active or more stable and away from center more active or less stable.

Note: When using the longer side on the swashplate rod rotate the mixing arm so that the longer side is on the left.

Hole location names for the flybar carrier

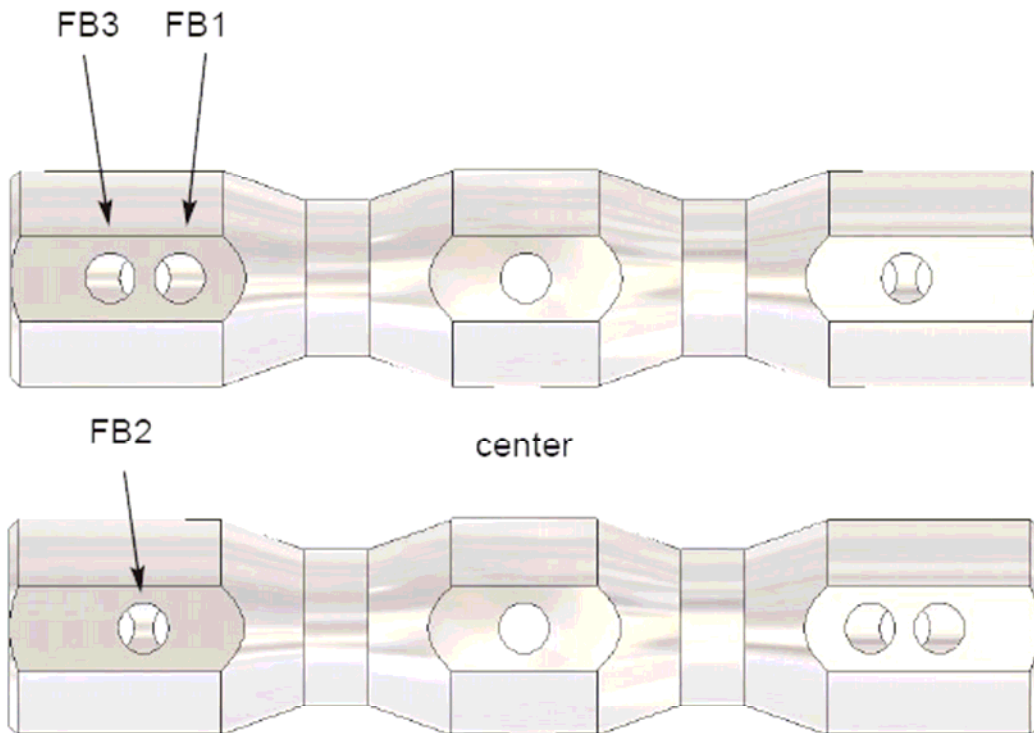

On the flybar carrier holes closer to the center pivot are more active and away from the center are more stable.

Note: Unless indicated otherwise all screws, balls and threads are installed with Blue Loctite

Hole location names for the blade grip

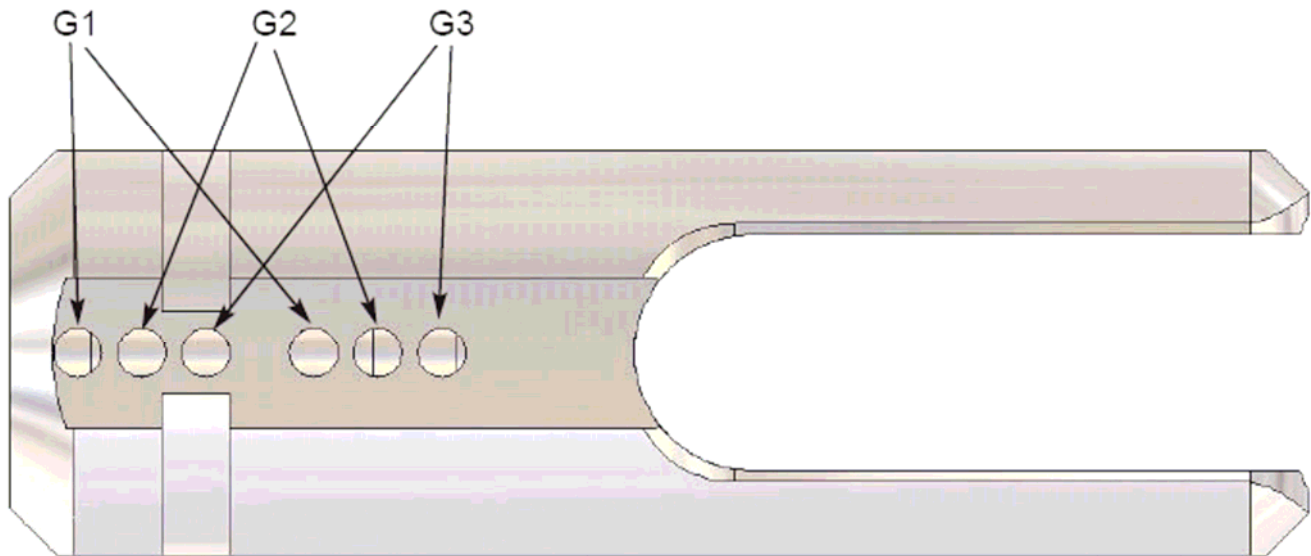

Holes on the blade grip and pitch arm affect the delta. Lower delta numbers are more active. Higher delta numbers are more stable. For all the delta settings please see diagram for delta settings in the manual.

Hole location names for the pitch arms

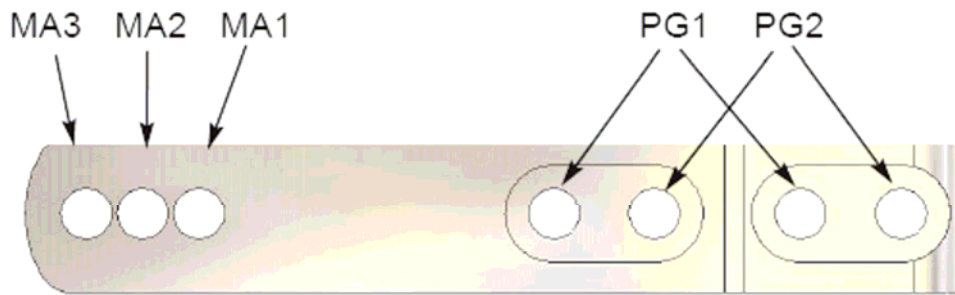

Holes on the blade grip and pitch arm affect the delta. Lower delta numbers are more active. Higher delta numbers are more stable. For all the delta settings please see diagram for delta settings in the manual.

Note: Unless indicated otherwise all screws, balls and threads are installed with Blue Loctite

Default basic head settings

Setting	Mixing arm Swash rod	Mixing arm Flybar rod	Flybar	Bladegrip	Pitch Arm Grip side	Pitch Arm MX arm hole	Resulting Delta
Ultra stable	ML3	MS1	FB3	G2	PG1	MA1	16
Stable	ML3	MS2	FB3	G3	PG1	MA3	14
Normal	MS2	ML2	FB2	G3	PG2	MA2	11
Active	MS2	ML2	FB2 or FB1	G3	PG2	MA3	7
Super Active	MS1	ML3	FB1	G2	PG2	MA3	3

Important note:

When using Active and Super Active settings the forces applied to the CCPM servos are larger than normal so plastic servo gears can suffer or break. Metal geared high torque servos are strongly recommended for those settings.

For pilots that want more precise adjustment of the delta settings here’s a guide on how to use the hole locations to vary the setting in small increments. A good starting point for the delta setting is position 7. (4 is Zero delta). # 7 position is achieved using holes number G3 on the bladegrip and holes number PG2 and MA3 (letter A on the drawing below) on the bladegrip pitch arm. Lower numbers make the cyclics more responsive. Higher numbers make them less responsive. (The pink dot indicates the location of the bolts)

Note: Most Team pilots are using: MS2, ML2, FB2, G2, PG2 and MA3

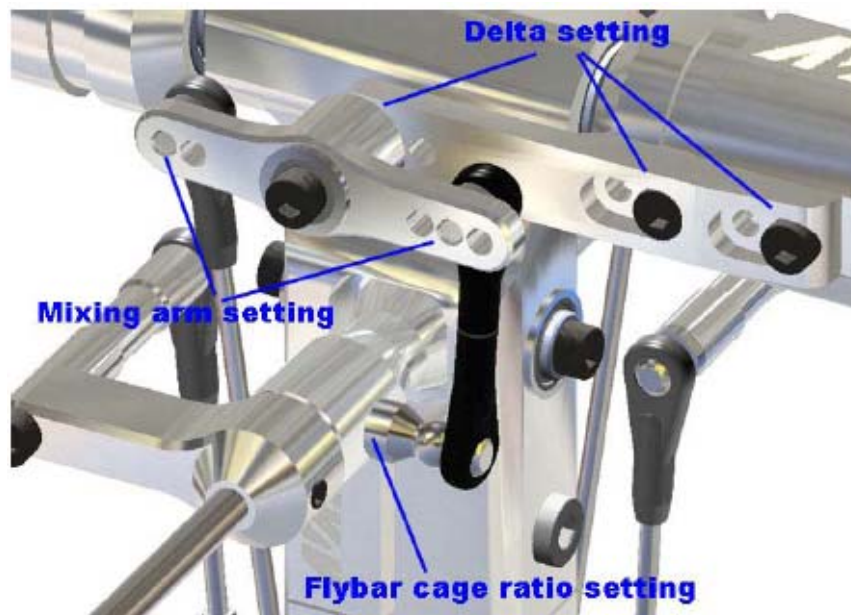

Note: Unless indicated otherwise all screws, balls and threads are installed with Blue Loctite

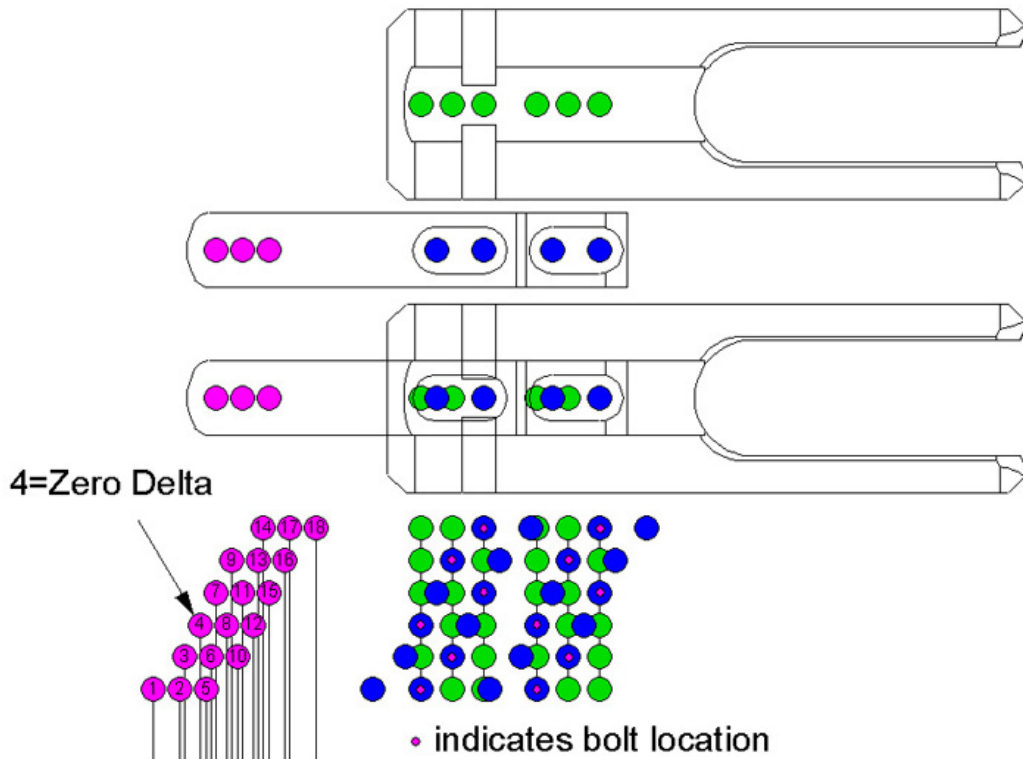

You can use up to 18 different delta settings in this head. Setting pictured in the assembly pictures above corresponds to setting number 7, which is a good point for 3D. Lower delta position numbers = more response (3D). Higher Delta position numbers = more stability. Keep in mind that not all delta setting positions are compatible with all mixing arm ball locations without rod binding against eh flybar cage so those might need to be adjusted.

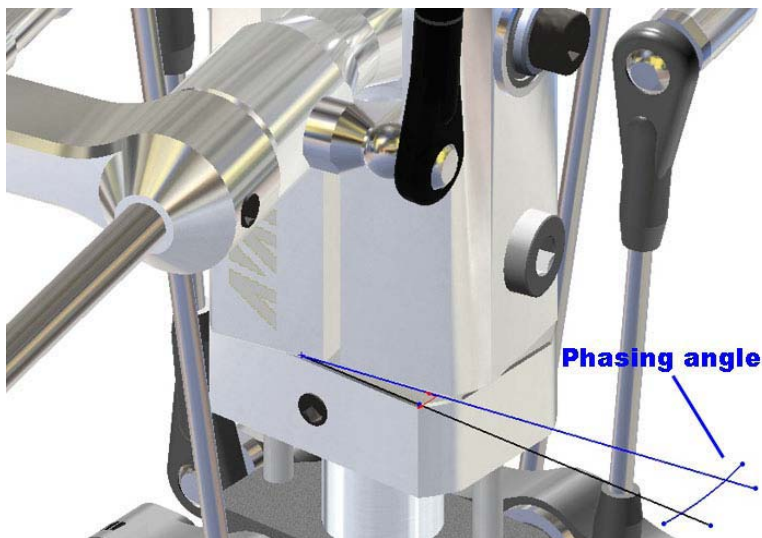

If you want you can also adjust the phasing to match your blades lead-lag angle and eliminate any tail corkscrewing during rolls if your blades have some. If you need to correct you can start with about 1 degree and build up from there.

Note: Unless indicated otherwise all screws, balls and threads are installed with Blue Loctite

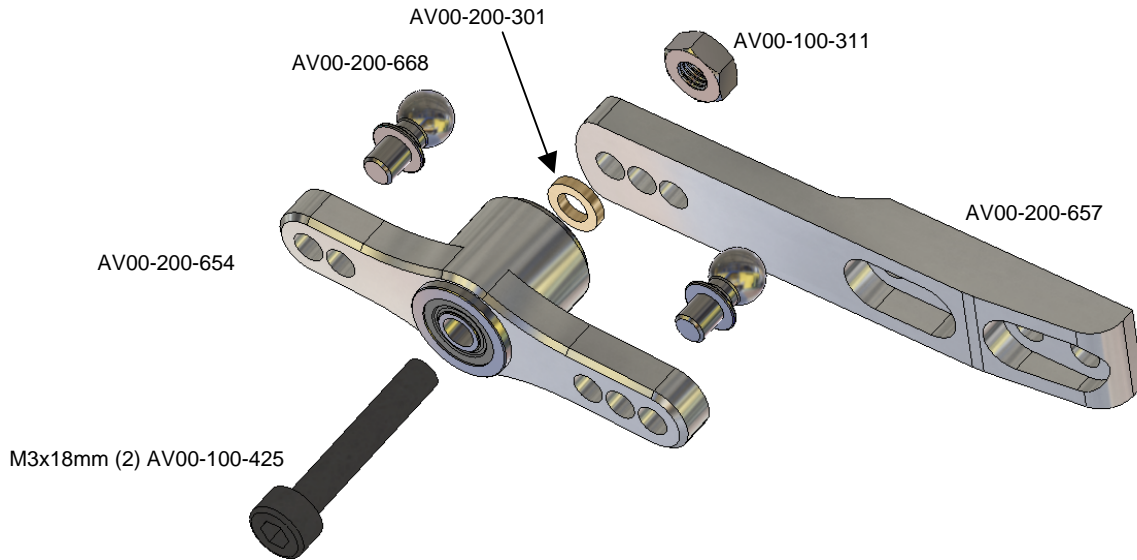

Use two swashplate balls per mixing arm. Use red Loctite here. Left ball closer to the center makes it faster (more swashplate to blades input). Right ball closer to the right makes it also faster (less flybar stabilization). Closer to the center makes it slower (more flybar stabilization).

Head Step 6)

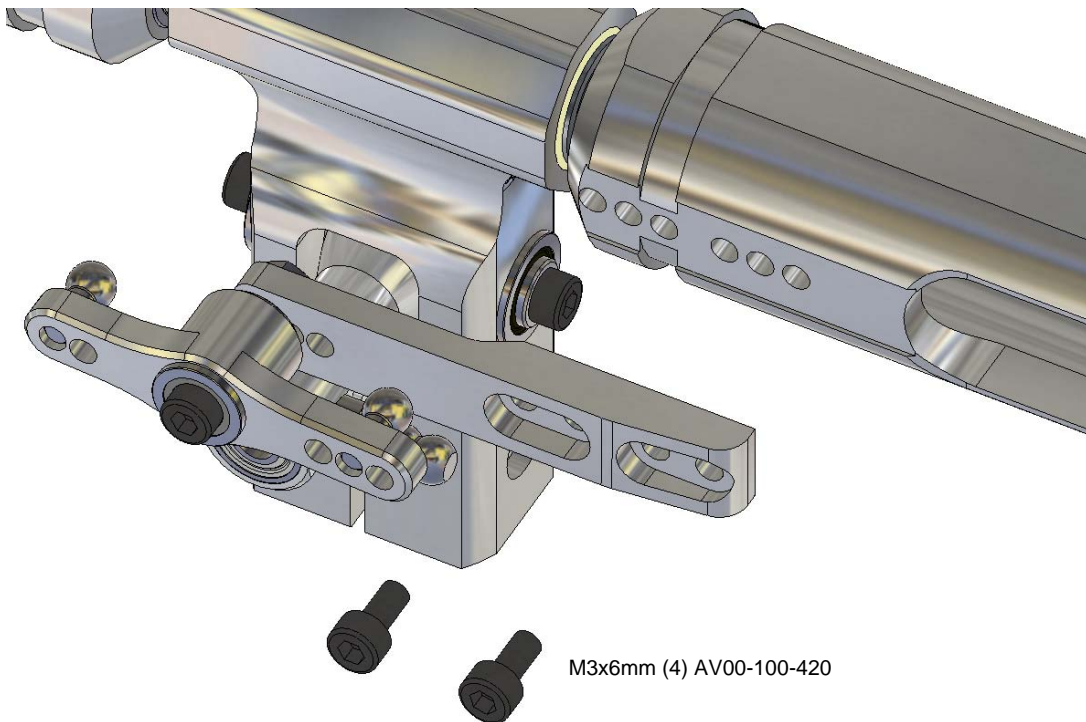

Use two M3x6mm screws to install the arm. Use red Loctite here.

Note: Unless indicated otherwise all screws, balls and threads are installed with Blue Loctite

Head Step 7)

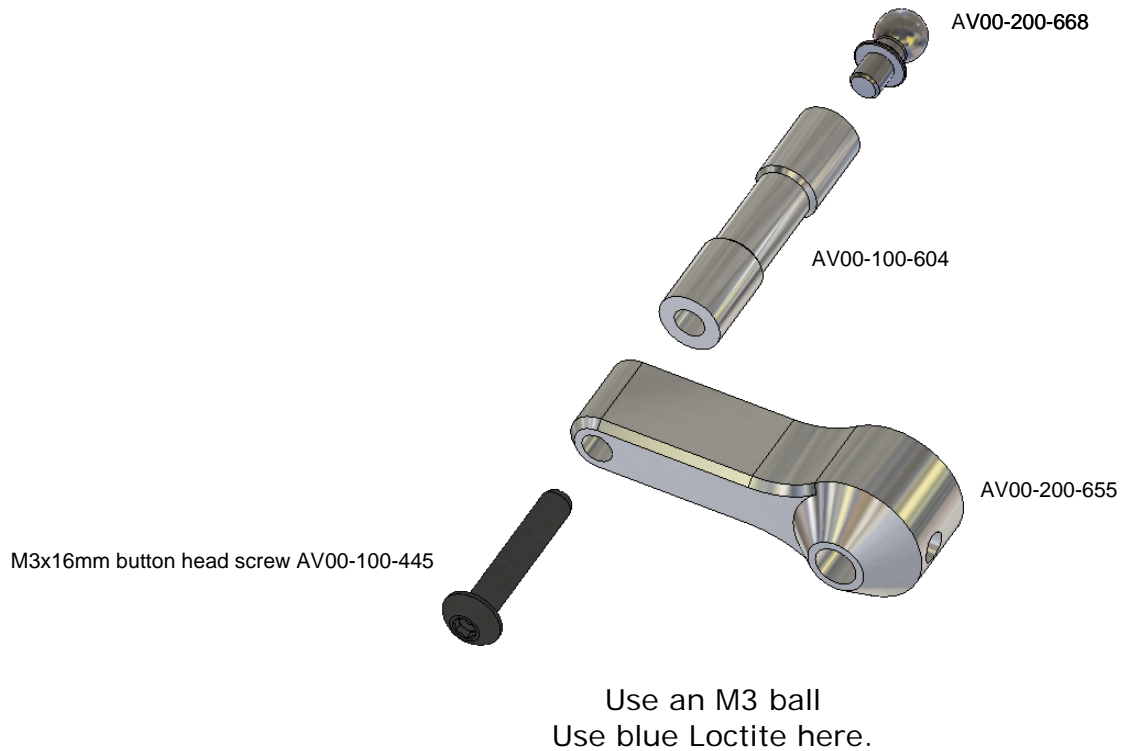

Head Step 8)

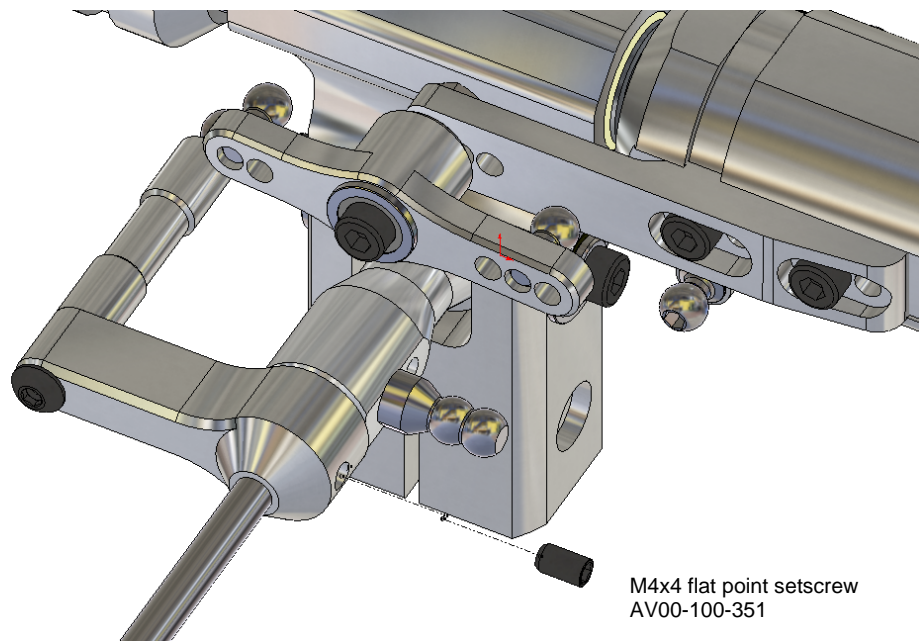

Install the AV00-200-651 555mm flybar and secure with two M4 flat point setscrews. Use blue Loctite here.

Note: Unless indicated otherwise all screws, balls and threads are installed with Blue Loctite

Head Step 9)

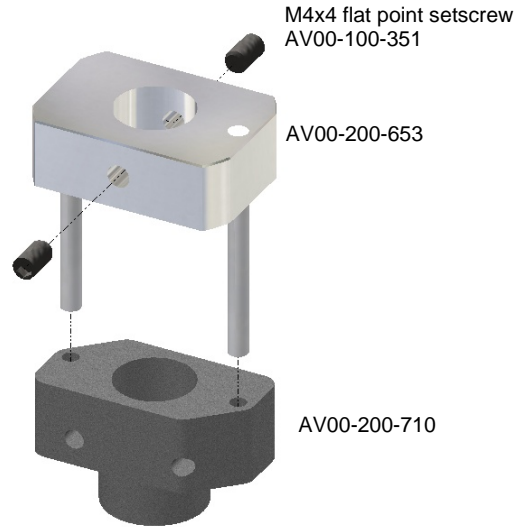

Use two M4 flat point setscrews

Head Step 10)

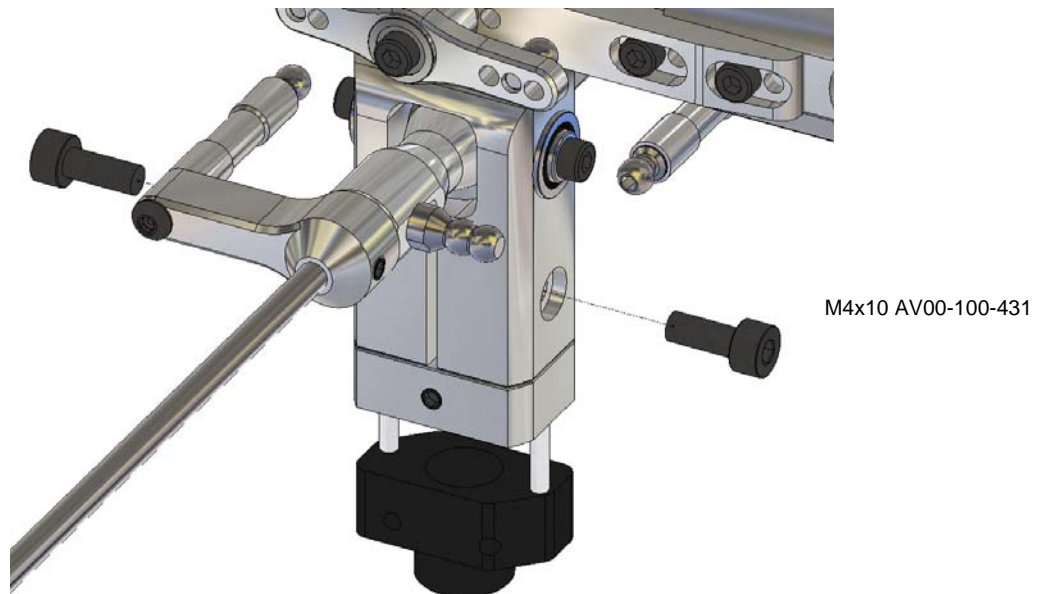

Install two M4 screws onto the Main shaft.
Use Red Loctite here and make them very tight.

Note: Unless indicated otherwise all screws, balls and threads are installed with Blue Loctite

Head Step 11)

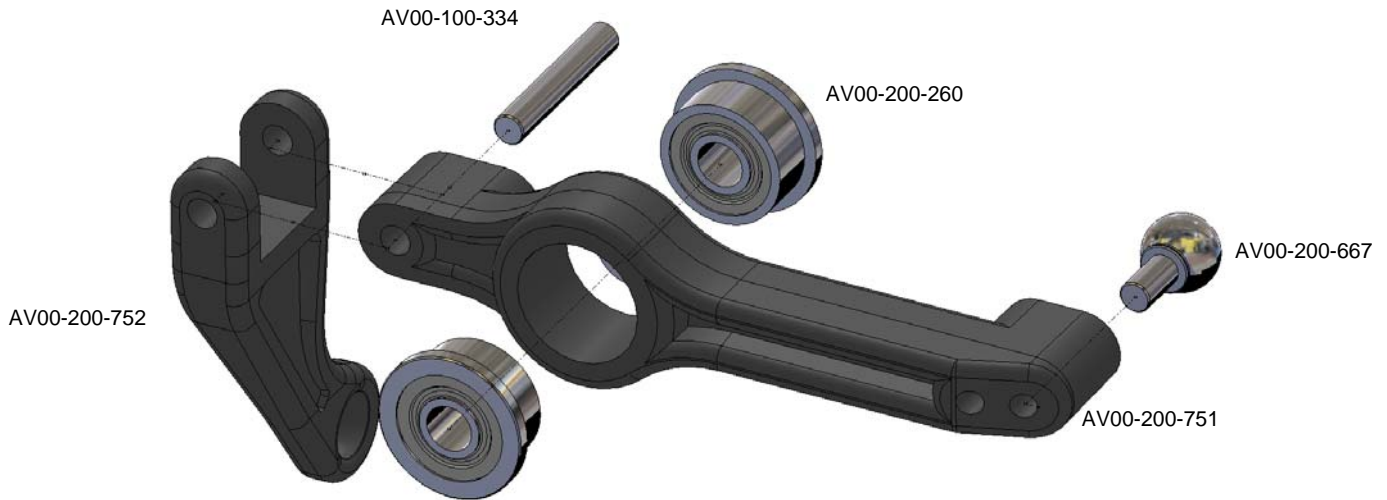

Assemble the washout arm as shown here. Clean any flash with an X-Acto knife and make sure the Y-Link rotates easily around the pin.

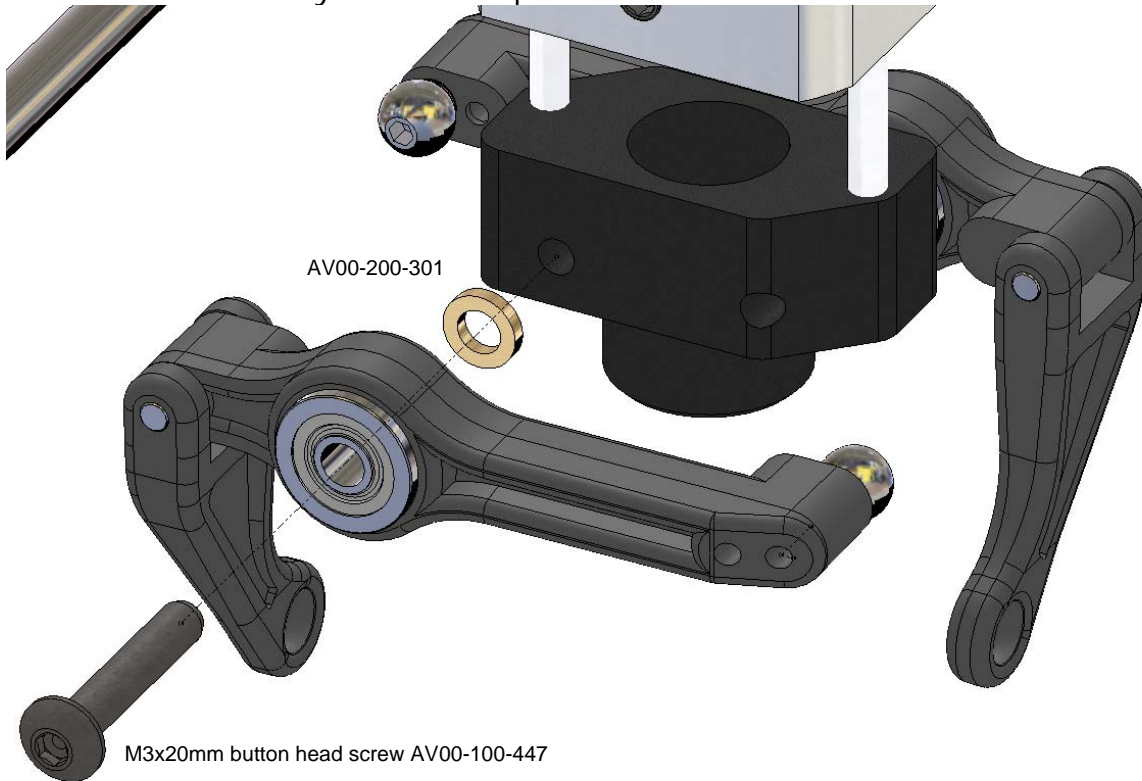

Use the 1mm spacer to install the washout arms. Use blue Loctite here. **Do not tighten the washout arm screws too much otherwise the washout base will bind against the shaft.** It's designed that way so you can tighten it as the washout base wears out with use.

Note: Unless indicated otherwise all screws, balls and threads are installed with Blue Loctite

Head Step 12)

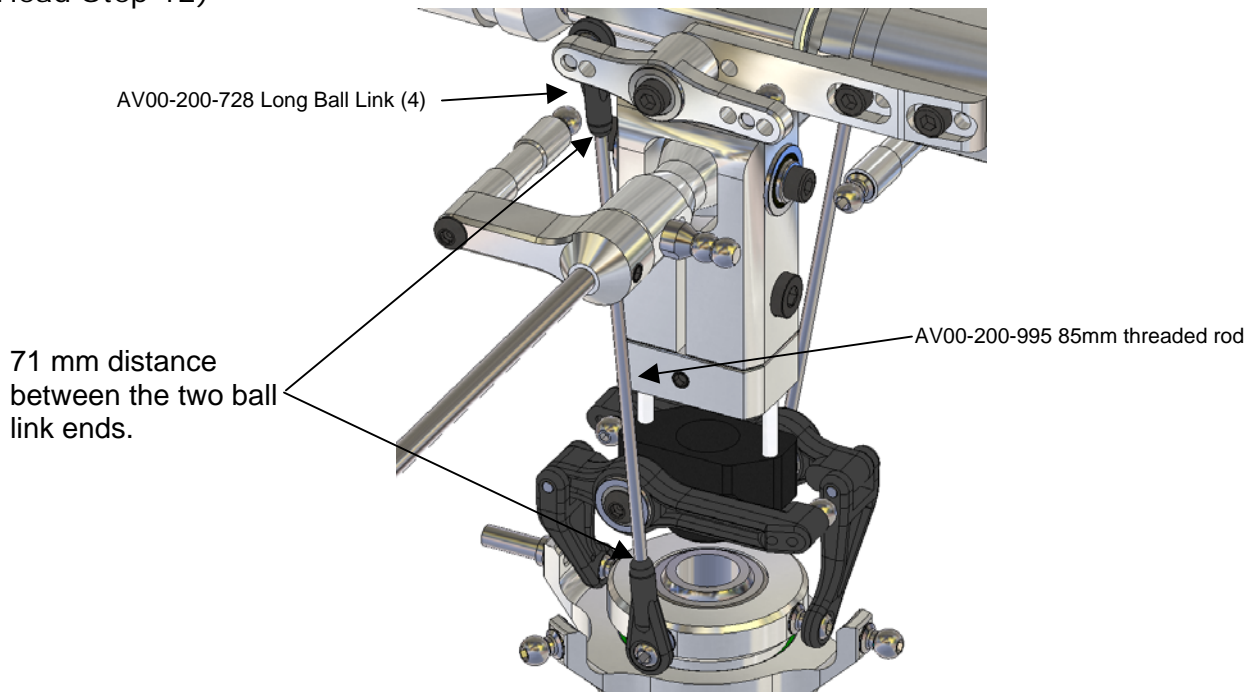

Install the supplied 85mm threaded rod and leave

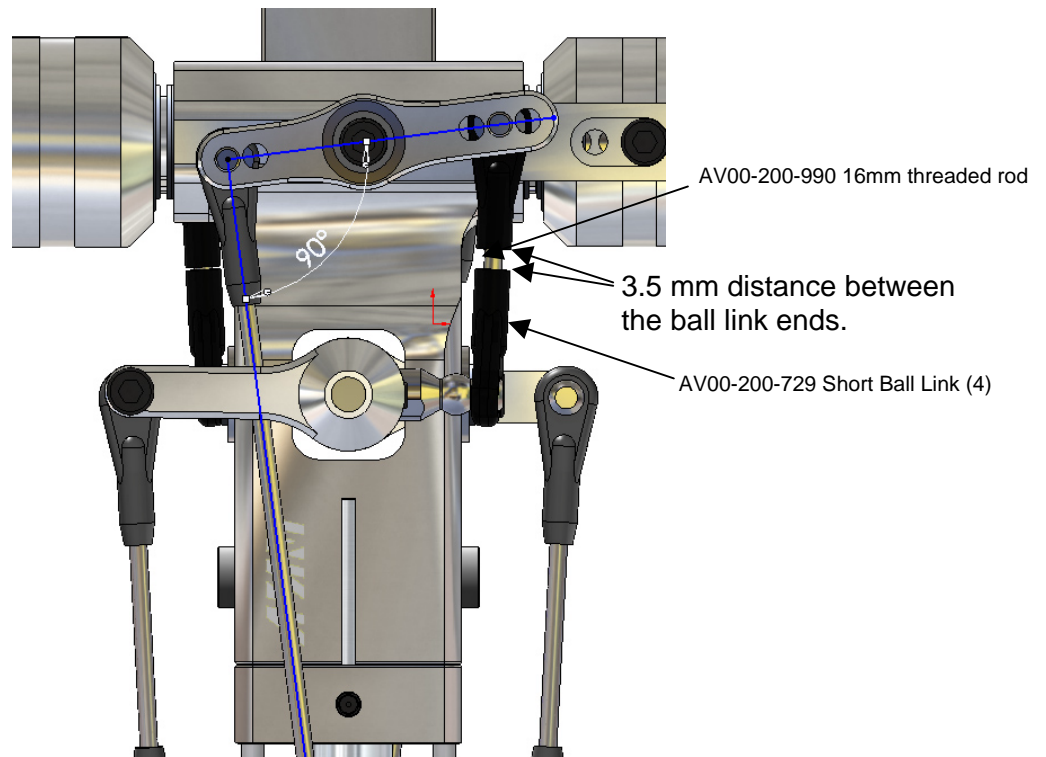

Install the 16mm threaded rod and **short ball links**. Make sure to align the rod and the mixing arm at 90 degrees when the swashplate is level and blades are at zero degrees or you will end up having more negative pitch than positive pitch. It will also cause the rod to appear too short.

Note: Unless indicated otherwise all screws, balls and threads are installed with Blue Loctite

Head Step 13)

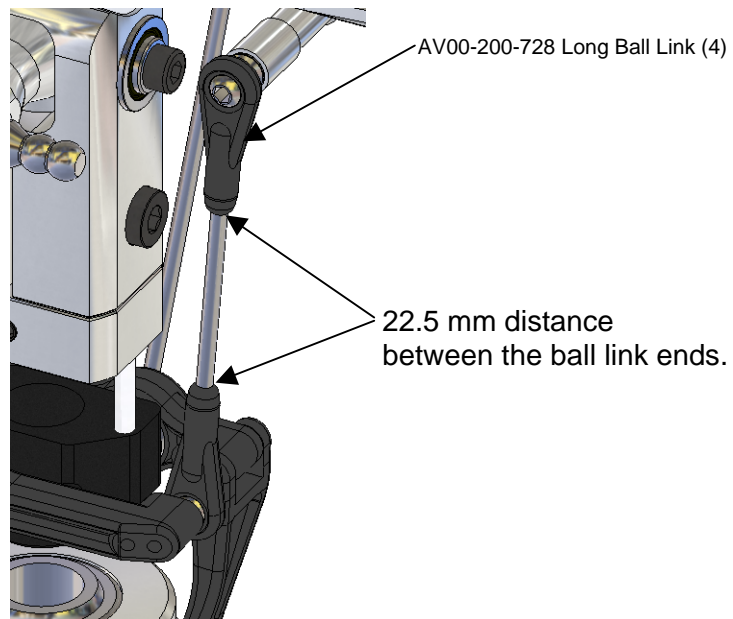

Install the 35mm flybar control arm threaded rod and links

Head Step 14)

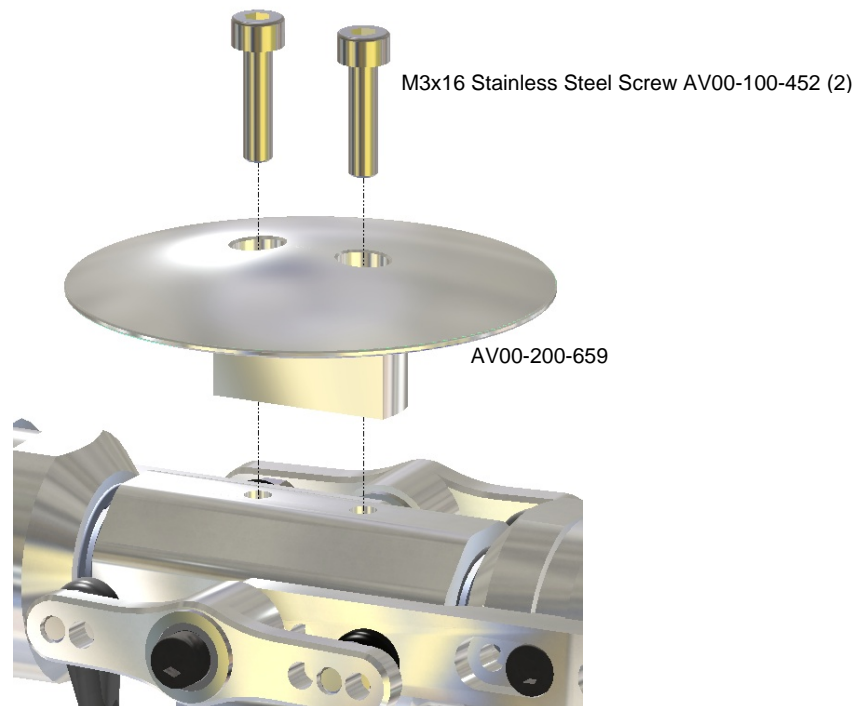

Install the head button with the Stainless steel screws.
Use blue Loctite here.

Note: Unless indicated otherwise all screws, balls and threads are installed with Blue Loctite

Bag #17: Radio installation

For the cases where the servo goes inside the frames here's the method to get it into the frames. Remember to take the rubber grommets of when installing larger servos like the 8717

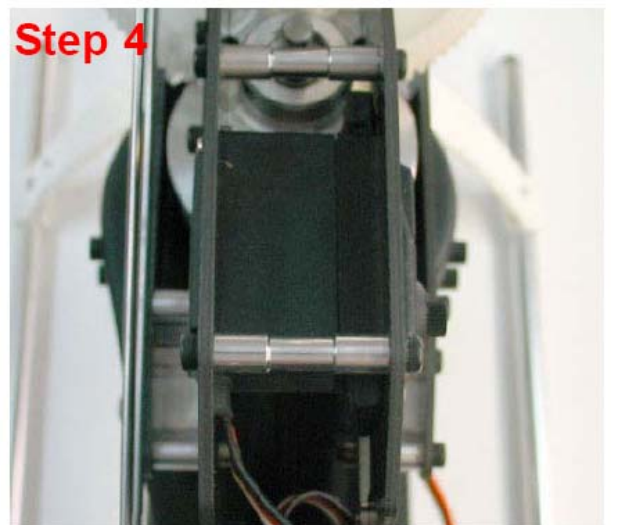
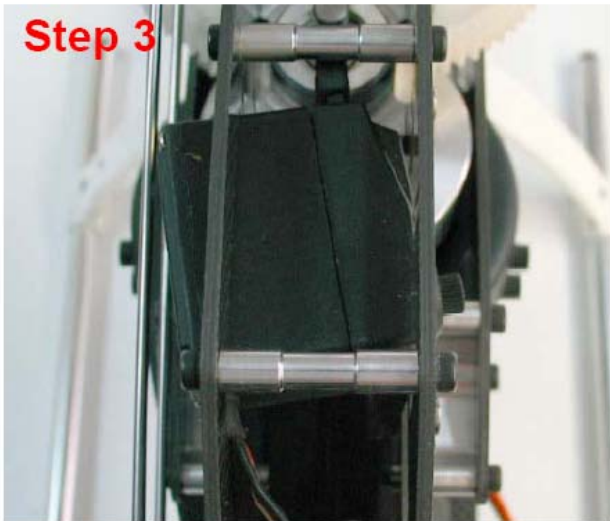
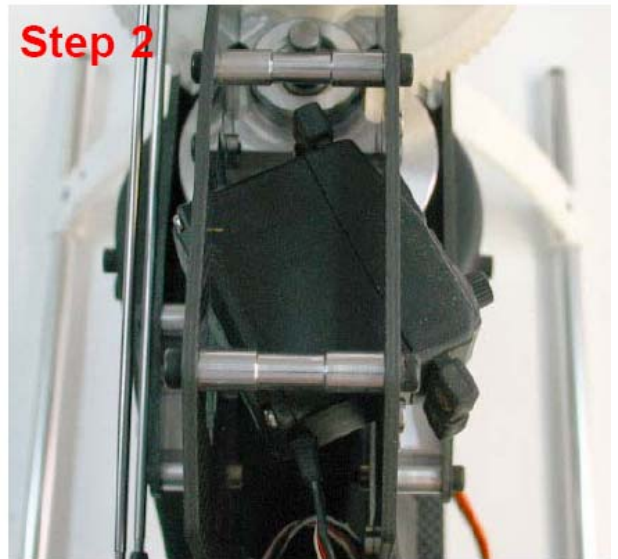
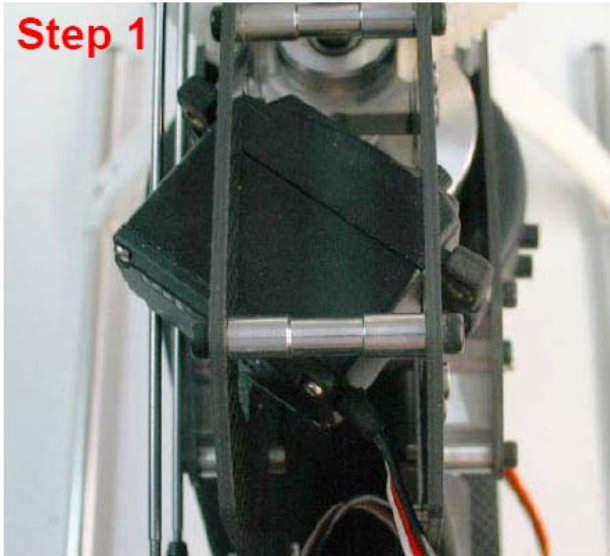

When installing the servo wires add a couple of layers of heat shrink to the servo wire at the rubber grommet to prevent the frames from chaffing into the wire and creating a short circuit.

Note: Unless indicated otherwise all screws, balls and threads are installed with Blue Loctite

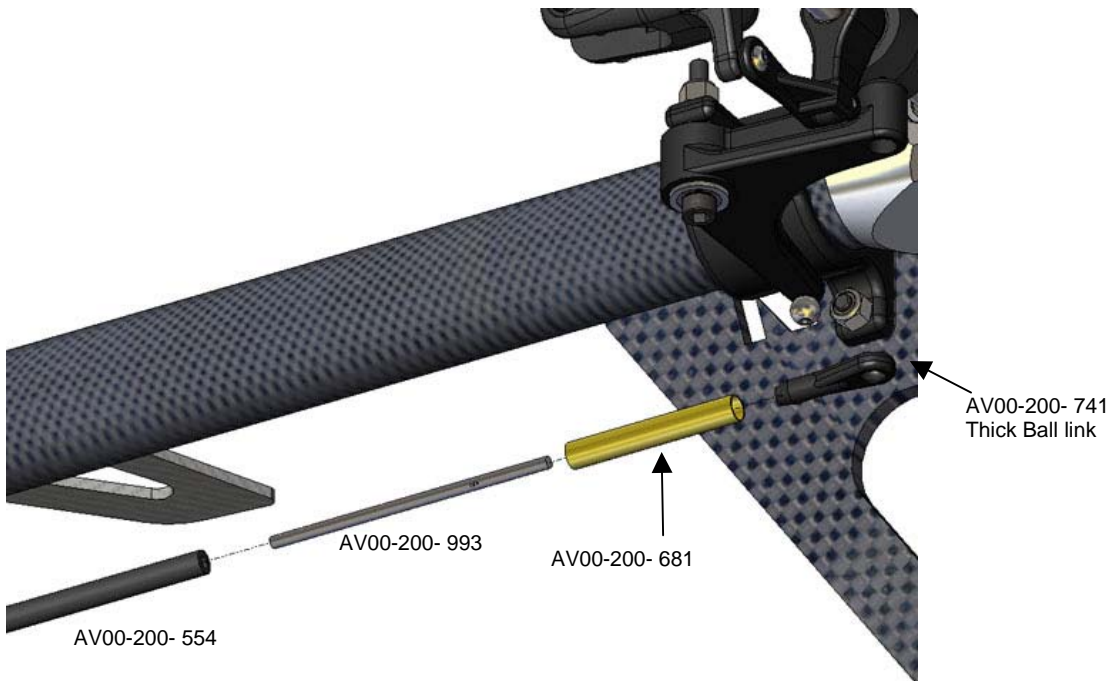

Thread the thick ball link into the 50mm threaded rod and use it to glue the threaded rod into the carbon rod with 30-minute. Epoxy or JB Weld. Once cured unthread it and then slide into the brass sleeve using pliers holding the ball link by the flat areas. Once slid into the brass thread is again into the pushrod. This method allows for a tight fit that prevents vibration without the need to glue the brass sleeve.

Note: Unless indicated otherwise all screws, balls and threads are installed with Blue Loctite

Front Tail Control Rod assembly.

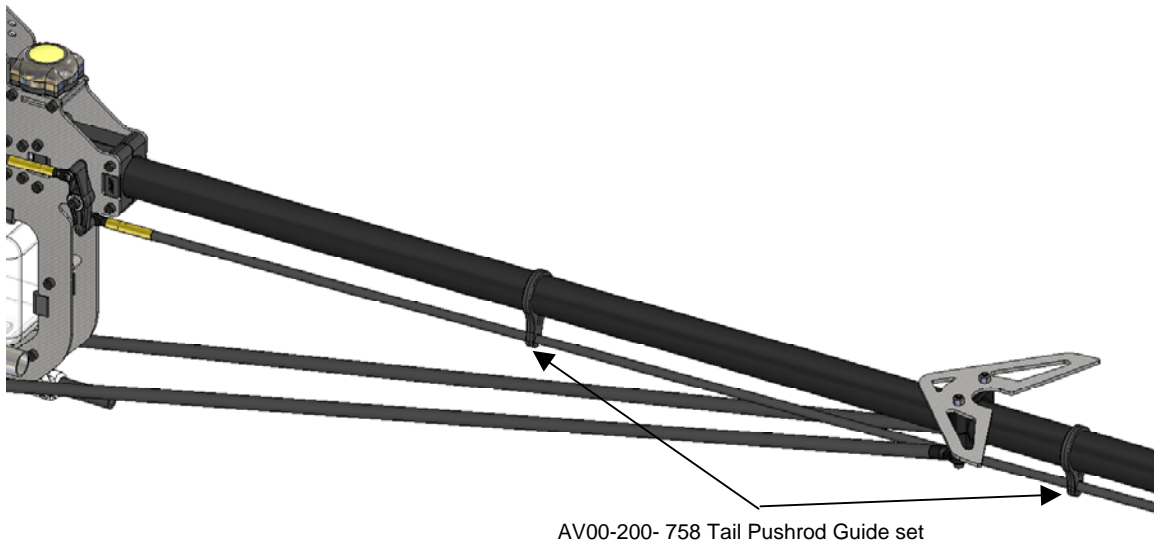
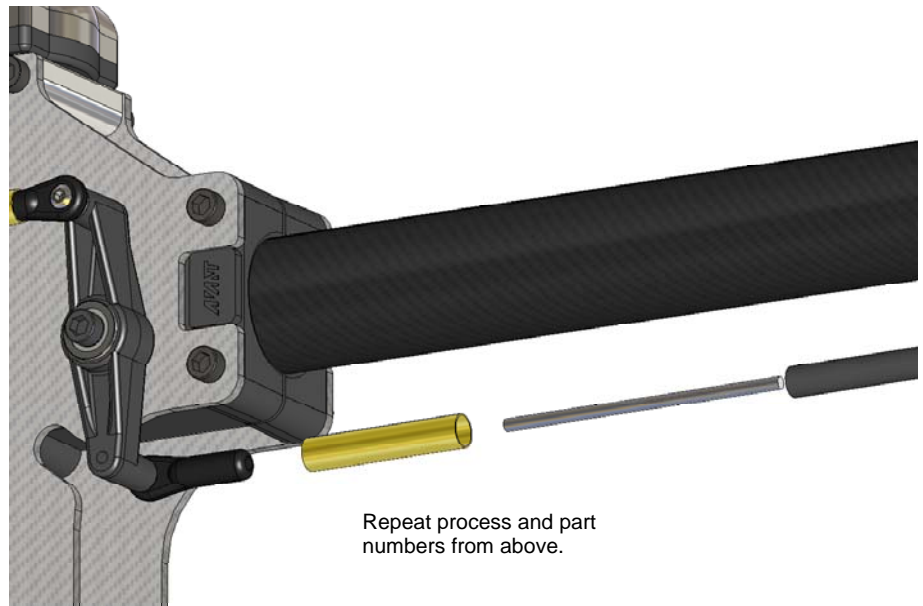

Install the long pushrod guide toward the front and the short toward the back. If needed after alignment is done use a drop of CA to fix the pushrod guide in place. Install the heat-shrink tubing and once you know where the pushrod guides will be and shrink them using a heat gun. Move the guides forward and back and rotate them accordingly until you reach a point where the pushrod goes from the tail to the frame bellcrank passing through the middle of the pushrod guide holes without touching them.

Note: Unless indicated otherwise all screws, balls and threads are installed with Blue Loctite

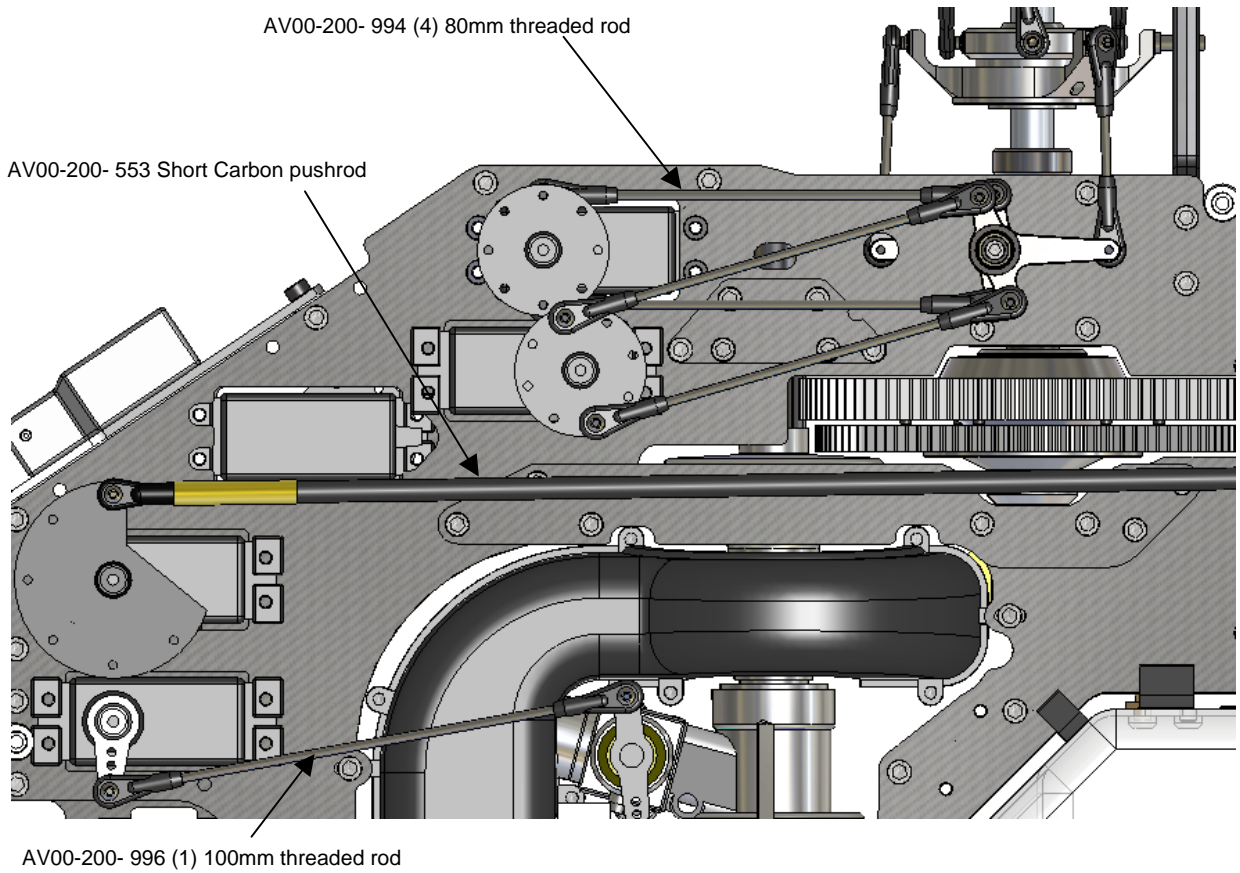
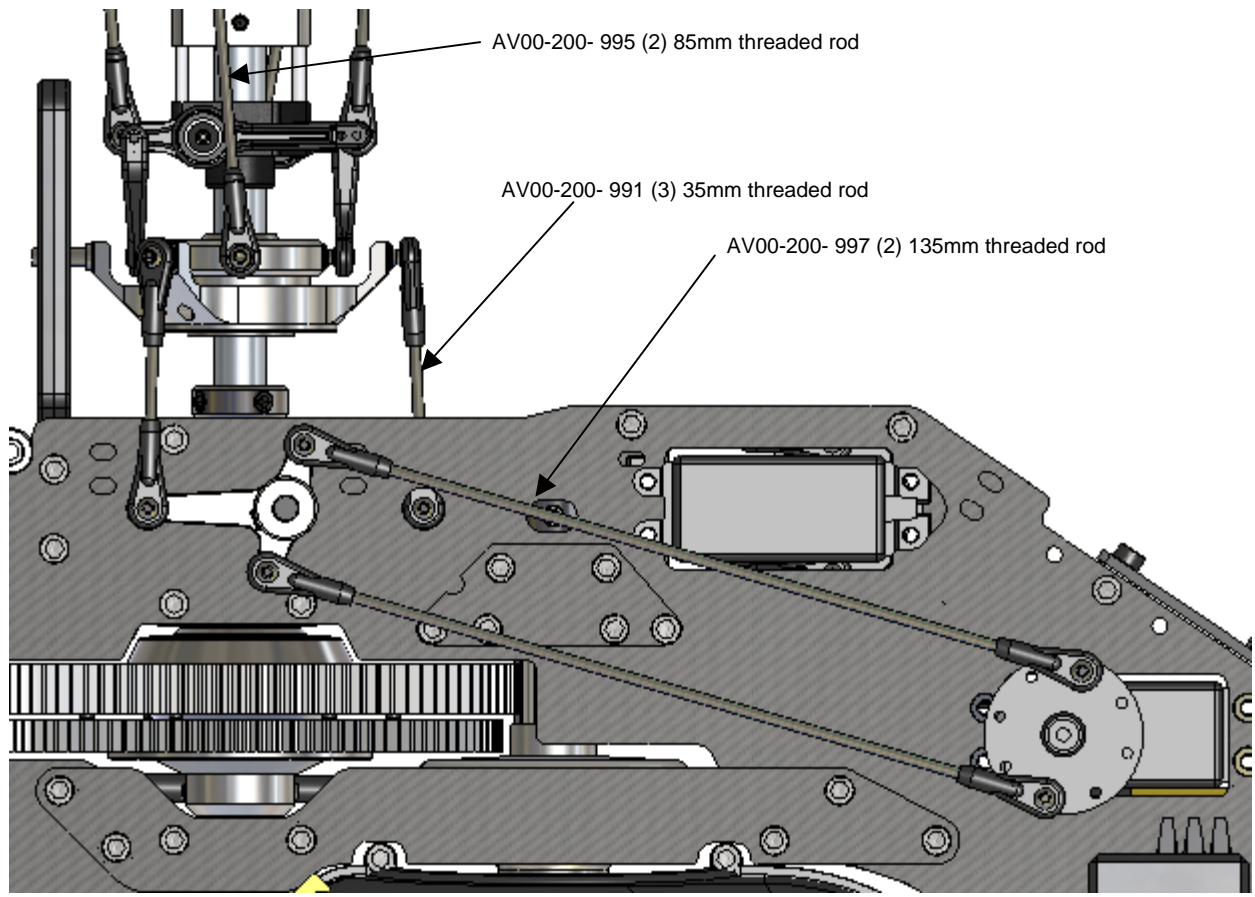

Note: Unless indicated otherwise all screws, balls and threads are installed with Blue Loctite

Recommended threaded rod distances.



All distances indicated below refer to distances from end to end of ball links.
Different servo brands will cause distances to differ from the ones listed below.

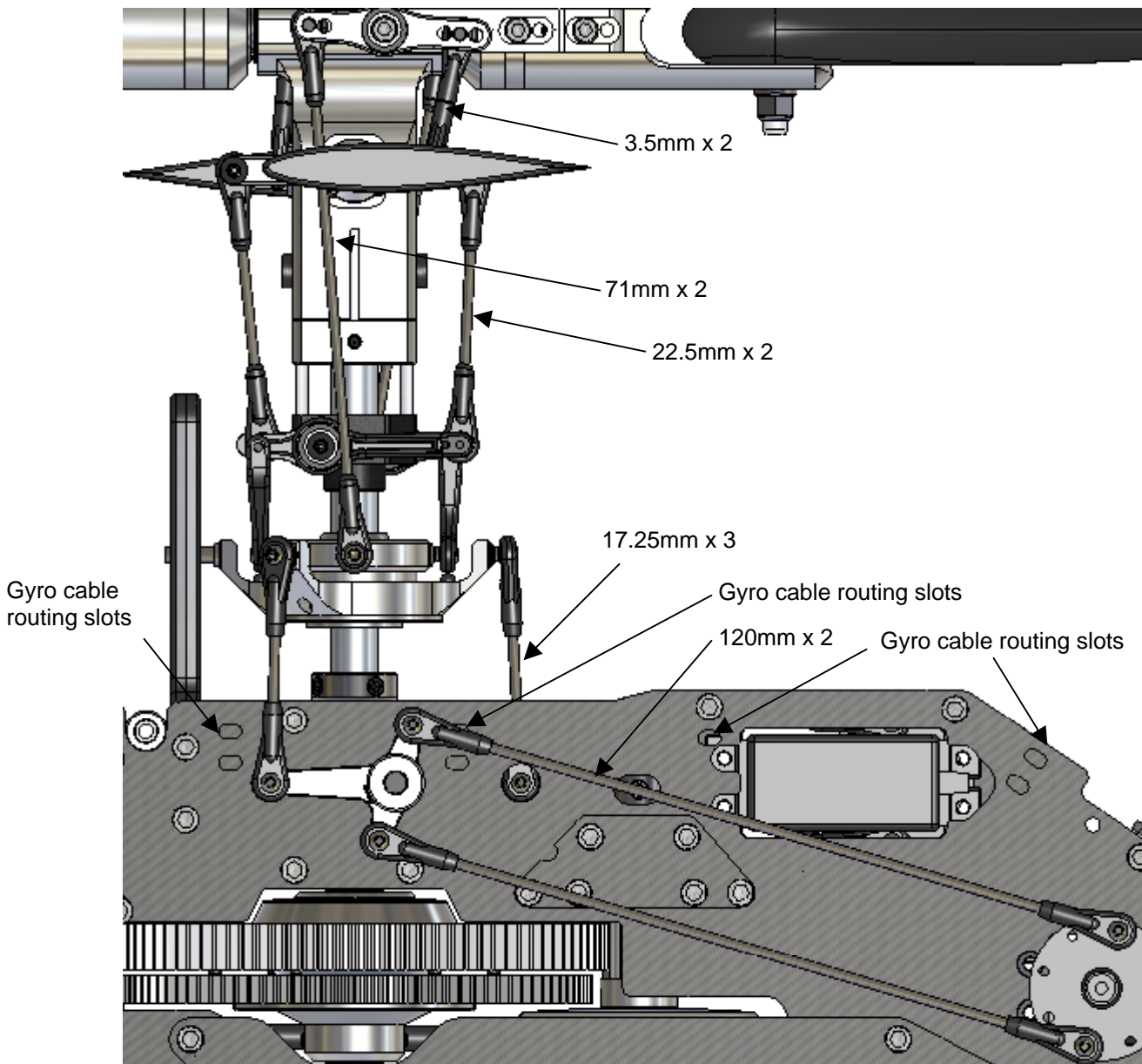

Note: Unless indicated otherwise all screws, balls and threads are installed with Blue Loctite

 **IMPORTANT Note:**
All the servo arms used on the cyclic servos should have a center-to-hole distance of 12.5mm to 13mm.

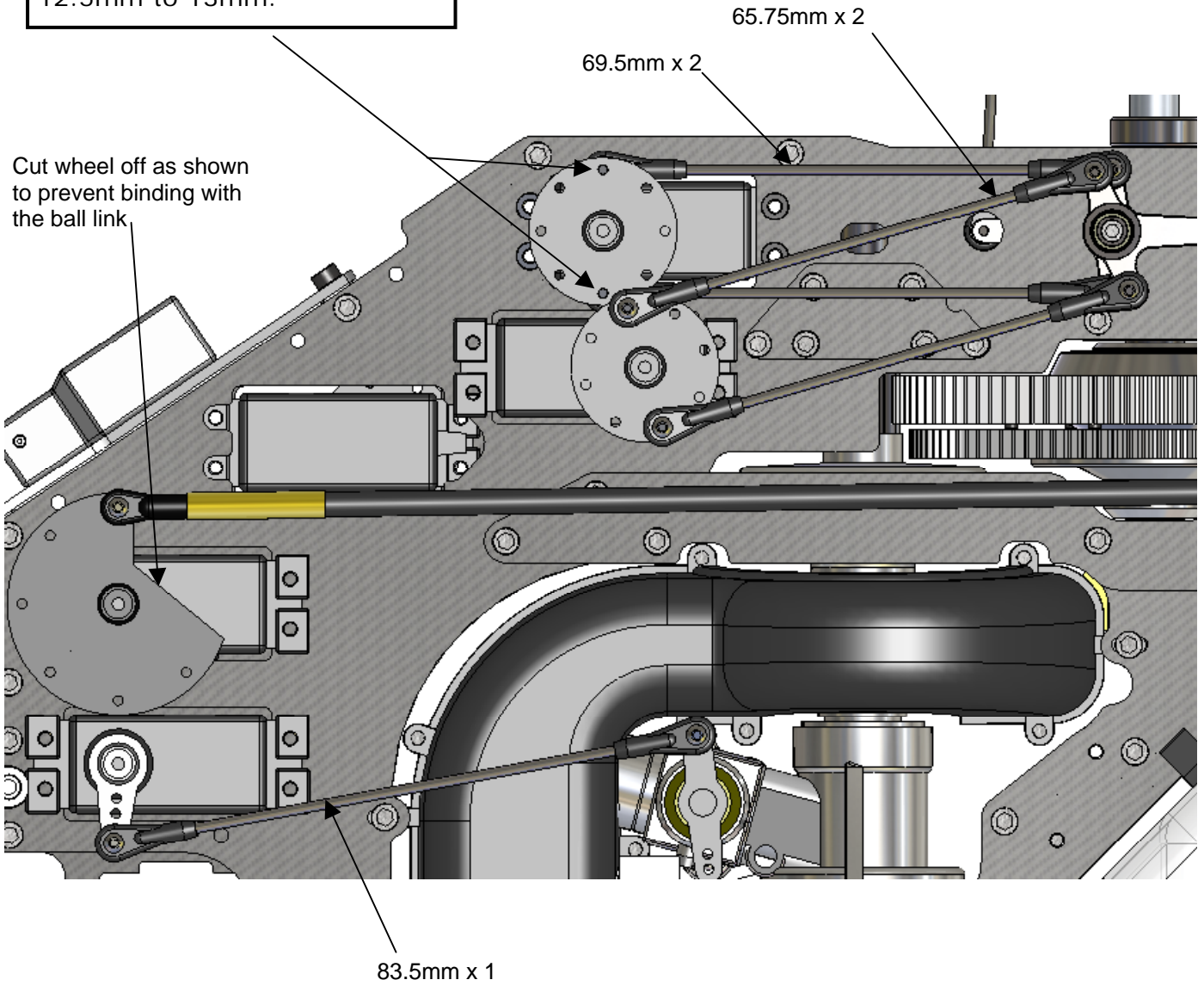

Note: Unless indicated otherwise all screws, balls and threads are installed with Blue Loctite

Ball links fit and sizing.

If needed for a final fit you can squeeze the ball link ring slightly with some pliers to make it a bit looser.

Keep in mind that the important thing is to make sure your ball links are secure so check and make sure the balls don't come out easily.

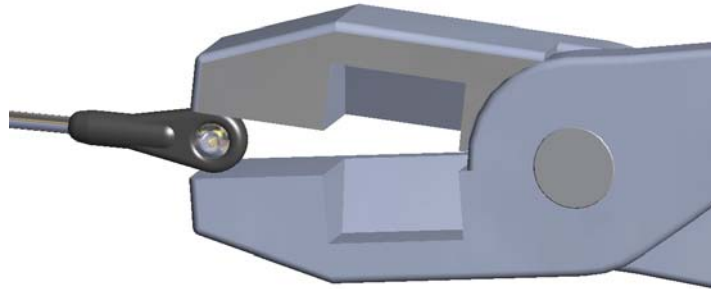

Canopy and Decals.

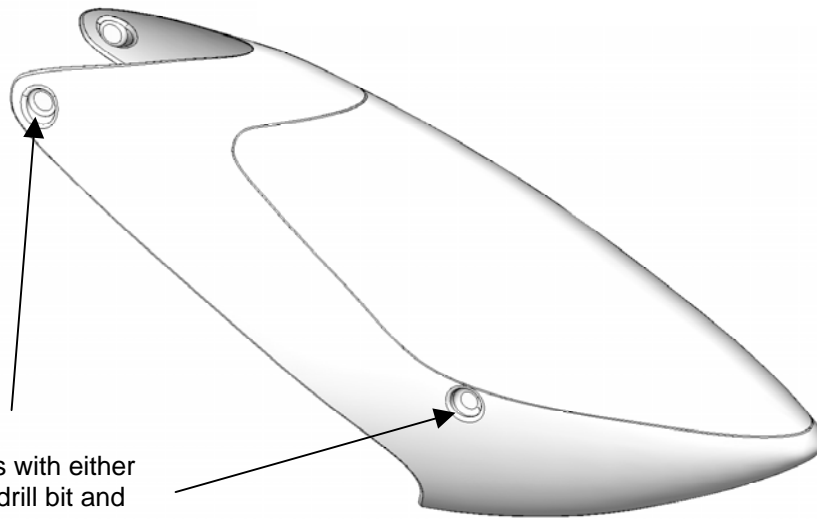

Open four 3/8" (9.5mm) holes with either a hole punch (preferred) or a drill bit and install the four rubber grommets.



Note: Unless indicated otherwise all screws, balls and threads are installed with Blue Loctite