

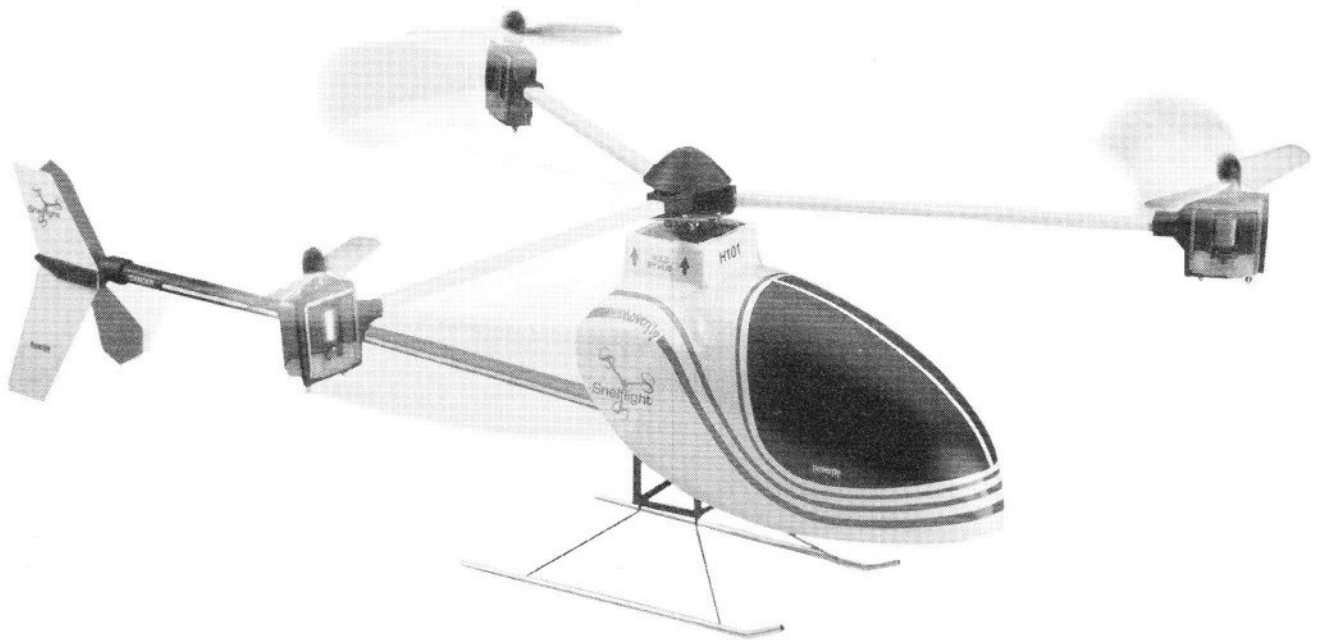

Hoverfly



Instructions and Maintenance Manual

INTRODUCTION

Congratulations on purchasing your Hoverfly, and welcome to the enchanting world of indoor electric flight! The Hoverfly is truly a helicopter in miniature. It can hover mesmerically in front of you, then dart off in any direction before hanging motionless in the air once more. It can dive swiftly downwards and swoop back up, or dance in graceful figures-of-eight whilst performing pirouettes.

The Hoverfly's unique and patented Electro-cyclic control system gives it an unmatched combination of rugged mechanical simplicity and authenticity in its representation of larger models. Since the Hoverfly is mains-powered, it can fly continuously and, best of all, it comes ready to fly, right out of the box.

The only setting up needed is to configure the Hoverfly's control system to your particular transmitter. We strongly suggest that you take the time to follow carefully the set-up procedure given in this manual, since this not only offers the best chance of a successful first flight, but also allows you to gain valuable insight into the Hoverfly's unique features, behaviour and capabilities. In the majority of cases some sections of the Manual can be skipped, and set-up will be completed in just a few minutes. The Hoverfly is different to all previous model helicopters, and a little time spent getting well acquainted with it now will be amply rewarded.

Have fun!

IMPORTANT NOTICE

Hoverfly is not a toy. It is an engineered model which although light in weight is capable of causing damage or injury if operated irresponsibly, primarily due to contact with the three thrust propellers. Avoid flying close to people or pets.

It may start up violently if the instructions contained in this manual are not followed, or if a fault occurs. To be sure of avoiding damage or injury always hold the centre of the rotor (keeping clear of the propellers) when switching on the mains power.

The motors become hot in use; to avoid injury do not touch until cool.

Unplug from the mains supply when not in use. Do not use in the wet.

Please note: Hoverfly is designed for trouble free flying, but for continued top performance, a little routine maintenance is recommended. See Section 14 for details.

CONTENTS OF THE MANUAL

Section	Section	Section
1. Introduction	7. Non-Standard Transmitters.	13. Overview of the Hoverfly.
2. Packing List	8. Setting Control Trims.	14. Maintenance.
3. Additional Items Required.	9. Commissioning.	15. Fitting the Window and Decals.
4. Handling the Hoverfly.	10. Pre-Flight Checks.	16. Tips and Troubleshooting.
5. Connections and Transmitter Settings.	11. Your First Flight.	17. Specifications.
6. Channel Assignment.	12. Helicopter Principles.	18. Spares.

2. PACKING LIST

This Manual:	Please read it carefully before attempting to fly the model.
The Helicopter:	It comes with its thin command line already attached.
Power Supply (with detachable mains lead):	This is the unit with a black lead attached. It converts power from the mains into 34V d.c. to power the model.
Electrocyclic Control Processor (ECP):	This is the black box with three electrical connectors. It hooks up to the trainer socket of a radio control transmitter, and converts its signal into a form suitable for the Hoverfly.
Signal Leads (2):	These are used to connect the ECP to a suitable R/C transmitter. One lead is fitted with a DIN plug, and is suitable for Futaba and Hitec transmitters. The other lead has a 3.5mm jack, and is suitable for JR and some Sanwa transmitters.
Spare Propeller:	This is specially selected as a match for the three propellers fitted to the Hoverfly. Its packaging carries a single digit thrust number.
Trainer Undercarriage:	Two lightweight tubes to attach to the skids whilst learning to fly.
Belt Insertion Tool:	Hook for threading the tail drive belt during maintenance.
Command Line Reel:	For convenient, safe storage of the Hoverfly's command line.
Decals, Stripes and Moulded Window:	For you to customise your Hoverfly.

3. ADDITIONAL ITEMS REQUIRED

The only additional item required is a control unit of the type normally used for radio control of models. If you are intending to move on to larger helicopters when you have qualified using the Hoverfly you may decide to invest in a transmitter with more features than the minimum listed below.

Minimum transmitter specification.

- Four control channels with two twin-axis (gimballed) joysticks.
- Fitted with a trainer (buddy box) socket, using PPM (pulse position modulation) signalling.
- Reversing switches on at least the first four channels.
- The transmitter should preferably use either the Futaba, JR, Hitec or Sanwa systems. Hoverfly will work with many others but the set-up procedure is more complicated.

4. HANDLING THE HOVERFLY

The Hoverfly should be held by the centre of the rotor, grasping it from above by the green printed circuit disc immediately below the rotor hub (Photo 1). Do not lift by the black dome, which pulls off easily. Alternatively, it can be held by the black plastic chassis, immediately above the undercarriage (Photo 2). On no account should it be held by the body or tail boom.

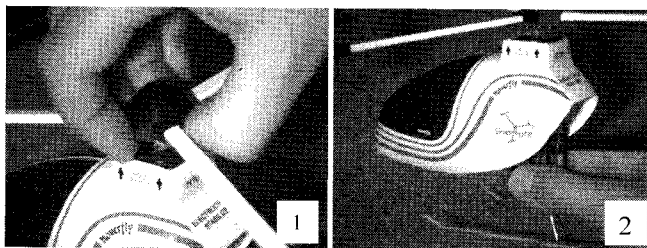

Photos 1 and 2: How to hold the Hoverfly.

Carefully lift the helicopter out of the box and place it on the floor. Uncoil the command line, taking care to avoid kinking it, guiding it away from the model rearward to ensure it will not foul the undercarriage or tail. **Do not allow the line to become kinked. Sharp bends will weaken it and must be avoided. (See also Section 14K).**

We suggest that newcomers to model helicopters should read Section 12 entitled Helicopter Principles before carrying on.

5. CONNECTIONS & TRANSMITTER SETTINGS

In order that the Hoverfly controls will work correctly with the particular type of transmitter being used, both the Electrocylic Control Processor (ECP) and the transmitter itself have to be set up correctly. For simplicity of setting-up, we recommend using one of the following Standard types of transmitter:

FUTABA HITEC JR SANWA

This is because these popular types can be set up according to the simple tables in this manual. Other types can be used, but it will be necessary to use a special procedure to determine the correct set-ups, since there are a great many different systems, which could not all be included here.

Connecting the transmitter to the Hoverfly system.

The transmitter communicates with the Hoverfly by way of an interface unit, the Electrocylic Control Processor (ECP), which is the small black box with electrical sockets at each end. This unit interprets the signal from the transmitter and uses it to control the amount of power sent to each of the motors on the Hoverfly. By varying the power levels in the right combinations, all the flight control functions of a conventional helicopter are created.

The transmitter connects to the ECP by means of a signal lead, of which two types are supplied with the Hoverfly. These leads allow connection of Futaba, Hitec, JR and some Sanwa transmitters. The lead is used to connect the transmitter trainer socket to the Signal socket on the ECP. For Futaba and Hitec transmitters, use the lead with the six-way DIN plug; for JR and Sanwa transmitters, use the lead with the 3.5mm jack plug.

NOTE ON SANWA TRANSMITTERS: Sanwa have fitted a variety of different training sockets to their transmitters. Early Vanguard models use a 3.5mm jack socket: these will work with the lead supplied, and all set-ups are the same as for JR. More recent Vanguards have a six-way DIN socket. These will NOT work using the Futaba/Hitec lead, because Sanwa use different pins in the DIN plug. The rest of the set-up procedure for these transmitters is, however, the same as for JR. More recently still, the RD6000 transmitter has been introduced, and this uses a five-way DIN socket. It is compatible with Airtronics products sold in the United States, and has to be set up differently. The details are included here. Snelflight can supply special leads for these various transmitters.

NOTE ON NON-STANDARD TRANSMITTERS: The great majority of transmitters can be used with the Hoverfly. However, we recommend caution in the use of the Futaba/Hitec lead for connecting up other makes, even if your unit appears to have exactly the right type of socket. This is because some of the pins are connected together inside the DIN plug, and the transmitter may be damaged if these pins happen to carry electrical signals which conflict. If your transmitter has a 3.5mm jack socket, it will generally be safe to try the JR/Sanwa lead, but if you are in any doubt, we recommend that you contact Snelflight for advice. We can arrange to supply a suitable lead in most cases. We are constantly seeking to expand our database on trainer leads and set-ups: we therefore welcome information on unusual ones.

Once you have the right lead, the equipment should be connected up as in Fig. 5-1, with the exception of the Hoverfly itself, which should not be connected yet.

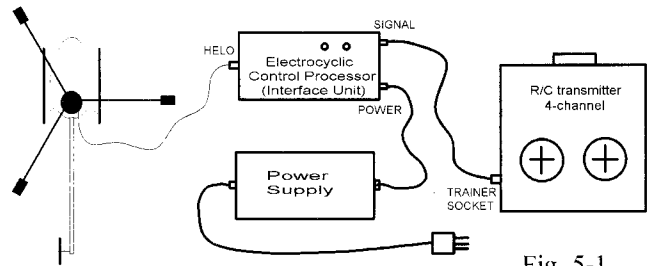

Fig. 5-1

Because the transmitter connects directly to the ECP, no radio communication is necessary. The transmitter's batteries are still needed to generate the signal at the trainer socket, but their lifetime is greatly increased, and there are no frequency conflicts or interference problems to worry about. It is therefore important to make sure that the transmitter's radiofrequency section is shut off when operating the Hoverfly. With some transmitters, the act of plugging in the trainer cord automatically switches on the power, whilst simultaneously turning off the radiofrequency circuitry. If this happens, the main power switch should be left in the off position. With other units, the power switch must be turned on, but the radiofrequency section should be disabled by removing the crystal.

The following settings and checks should now be made.

a) Signal Mode Selection: If your transmitter offers PCM as well as PPM signalling, switch it to PPM. **THIS IS VERY IMPORTANT.** PCM-only transmitters **cannot** be used with the Hoverfly, but these are fortunately very rare. Attempting to operate in PCM mode will cause the Hoverfly to start violently as soon as the power is switched on.

b) Servo Travel: If your transmitter has adjustable servo travels (endpoint adjustments), set the first four channels to 100% in both directions of throw. Exponential joystick response can be selected if you wish.

c) Channel Centres: If your transmitter has channel centre adjustments, these should be set to zero (centred) on the first four channels. The external trim tabs should also be centred.

d) Mixing Functions: If your transmitter has mixing functions, such as Throttle to Rudder mixing, these should be switched off, or set to zero.

e) Throttle Curve: If your transmitter has a throttle curve feature, it should be set up to give a full range, linear throttle response. Make sure that the Throttle Hold switch is turned off, too. Some transmitters have an Aeroplane mode, in which these functions are de-activated. It is usually easier to use this mode with the Hoverfly.

f) Some transmitters have mechanical stops on the throttle stick, which limit movement to less than 100%. This reduces the available Collective range on the Hoverfly, making climbout sluggish. It is easy to see if a transmitter has these stops, by comparing the physical positions of the left and right sticks when pushed fully forwards (or backwards). The stops typically reduce throttle throw by about 20%. We offer the following solutions:

- i) On computer transmitters, the throttle channel endpoint adjustments can be set to 120% (in both directions) to compensate for the reduced stick movement.
- ii) On more basic transmitters, the throttle trim can be pushed forwards to compensate for the reduced upper joystick range. Unfortunately, this compounds the problem at the bottom end, and often means that the Hoverfly doesn't shut off completely unless the trim is returned to the centre.
- iii) As a last resort, the mechanical stops can usually be removed. They often take the form of wedge shaped pieces of plastic, which are screwed to part of the gimbal mechanism. By carefully comparing the left and right stick mechanisms, the culprits can generally be spotted. Because this involves opening the transmitter, it may affect the manufacturer's warranty, but it is normally only necessary on inexpensive transmitters without endpoint adjustments. The stops can usually be put back later, if needed.

g) Now switch on the mains supply: The red Power light should illuminate on the ECP.

h) Switch on the transmitter (if not automatic): The green Signal light should illuminate on the ECP after approximately 2 seconds delay.

Now switch everything off. (Remember that some transmitters remain on until the trainer plug is removed).

For successful set-up, the steps in Sections 6 to 8 must now be completed. Please follow them carefully.

6. CHANNEL ASSIGNMENT

WARNING: NEVER SWITCH ON THE POWER WHILST THE HOVERFLY IS CONNECTED UNLESS YOU ARE SURE THAT THE CHANNELS ARE PROPERLY CONNECTED AT THE PATCH SOCKET. ESPECIALLY, DO NOT SWITCH ON OR ATTEMPT TO FLY WITH SOME CHANNELS UNCONNECTED. UNCONNECTED CONTROL FUNCTIONS WILL HAVE UNDEFINED VALUES, AND WILL BEHAVE UNPREDICTABLY. THE HOVERFLY MAY START UNEXPECTEDLY. BE CAREFUL!

The Hoverfly has four flight control functions; Collective, Aileron, Elevator and Rudder. Each of these is associated with one of the four axes of joystick movement provided on the transmitter. Information about the positions of the joysticks at any moment is sent to the ECP by means of four transmitter channels, one for each flight control function. On any transmitter, these will always be the first four channels, regardless of the total number of channels the transmitter has.

It is of course important to ensure that each flight control function is operated by the correct joystick. On a conventional model, this is done by connecting each control servo to the appropriate channel on the radio receiver. Because the Hoverfly has no receiver or servos, a **Channel Patch Socket** is provided within the ECP for this purpose. This has two rows of four electrical terminals. Channels 1, 2, 3 and 4 from the transmitter

arrive at the terminals on the left, whilst those on the right lead to the flight control functions C, A, E and R (Collective, Aileron, Elevator and Rudder). The Patch Socket allows the flight control functions to be connected to the four channels in any combination, so that a wide variety of transmitter types can be used with the Hoverfly.

To gain access to the Channel Patch Socket, it is necessary to open the ECP (see Section 14L for instructions). Fig. 6-1 shows the location of the Patch Socket. Patching is done using four black link wires, which plug into the socket terminals. Text on the circuit board identifies each terminal. The links may be crossed over each other, but each link must connect *across* the socket, linking a channel to a control function, and when the set-up is complete all four links **must** be in place.

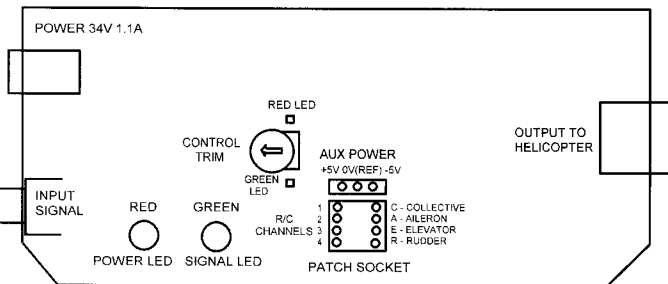

Fig. 6-1 Location of Channel Patch Socket

Mode 1 and Mode 2 Operation.

The terms Mode 1 and Mode 2 refer to the two joystick arrangements commonly used by model helicopter pilots. Mode 2 is more popular and is described first. Information on Mode 1 operation is included at the end of this section. Fig. 6-2 shows how the controls are laid out in Mode 2.

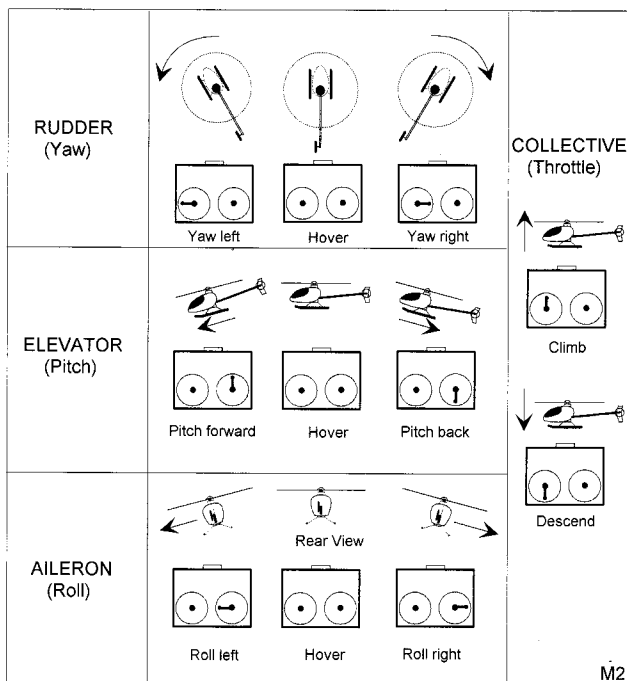
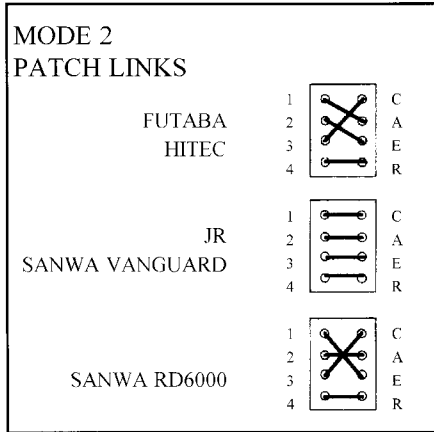

Fig. 6-2 Mode 2 Control Layout.

The ECP comes factory preset for Mode 2 operation with Futaba and Hitec transmitters. To set up Mode 2 for one of the other Standard transmitter types, simply pull out the four link wires, and plug them back in according to the diagrams below. **Always switch off the power before removing or inserting the link wires. The electronics can be damaged if anything metal touches the circuitry whilst the power is on.**



Mode 2 Patch Links

NOTE: These set-ups assume that the transmitter channel sequence is as per the manufacturer's standard. Some computer transmitters allow the channel sequence to be changed by the user, and this will cause incorrect operation of the Hoverfly. It is vital that the transmitter itself is set up in the standard way. Many models have a procedure for restoring the factory settings. More basic transmitters are actually easier to use with the Hoverfly!

Setting the Servo Reverse Switches.

After setting up the Patch Socket, it is necessary to set the correct direction of movement for each channel. This is done by means of the transmitter servo reverse switches. These must be set according to Table 6-1 below.

Channel	1	2	3	4
Futaba	Normal	Normal	Normal	Normal
Hitec	Normal	Reversed	Reversed	Normal
JR	Reversed	Reversed	Reversed	Reversed
Sanwa(inc RD6000)	Reversed	Reversed	Reversed	Reversed

Table 6-1 Reverse Switch Settings

Mode 1 Operation.

The majority of pilots wishing to fly in Mode 1 (throttle on the right) format either use a transmitter which has been specifically supplied as a Mode 1 unit, or one which has a Mode 1 option built-in. In such cases, the Hoverfly set-ups will be **the same as for Mode 2**. On occasions however, the owner may convert a Mode 2 transmitter to Mode 1 mechanically, by transferring the return spring from one joystick to the other. As a result, the Throttle signal occupies the channel originally assigned to the Elevator, and vice versa. To fly the Hoverfly with such a transmitter, the Patch Socket should be set up as below. Fig. 6-3 shows how the controls are laid out in Mode 1.

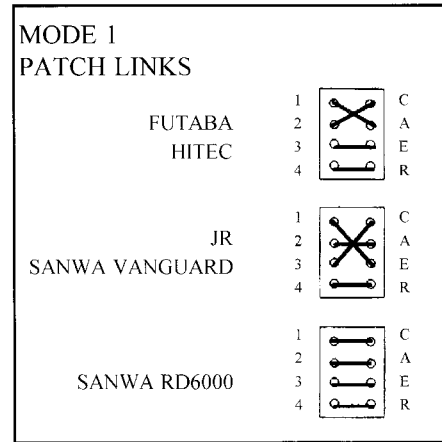

Mode 1 Patch Links

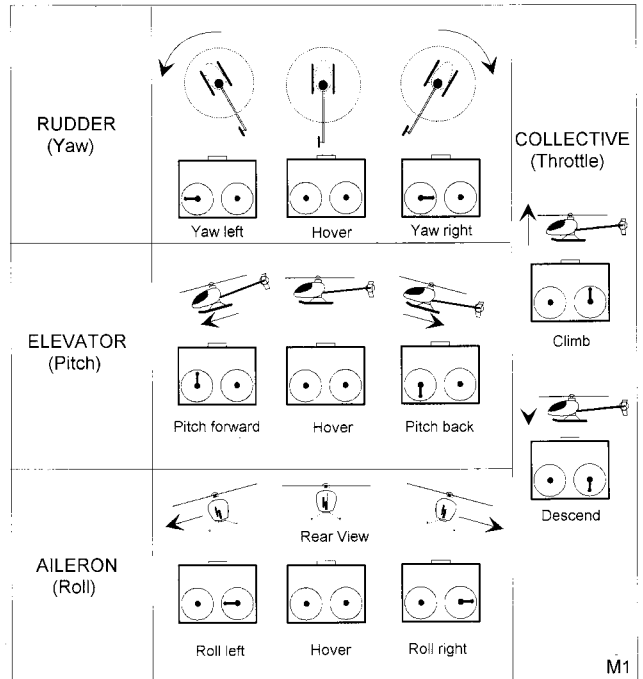

Fig. 6-3 Mode 1 Control Layout

Setting the Servo Reverse switches.

After setting up the Patch Socket, it is necessary to set the correct direction of movement for each channel. This is done by means of the transmitter servo reverse switches. The settings are the same as for Mode 2, and are given in Table 6-1.

7. NON-STANDARD TRANSMITTERS

Assigning Channels and Setting the Transmitter Servo Reverse Switches.

If you are using a Standard transmitter, please skip this section and move on to Section 8.

If your transmitter is not one of the Standard types with set-ups given in Section 6, it will be necessary to carry out a special procedure to determine the correct settings for both the ECP Patch Socket, and the transmitter servo reverse switches. The ECP has facilities which allow the correct set-ups to be determined before the Hoverfly is ever connected, making the process relatively straightforward.

Two small LEDs, located on either side of the Control Trim Adjuster (Fig. 6-1), are connected by circuitry in the ECP to the Patch Socket Rudder (R) terminal. They indicate when the Rudder is pushed to the left (red LED), or to the right (green LED), or centred (neither LED). They will be used later to trim the ECP.

These LEDs have another important function. They allow the operation of any of the four channels to be monitored, simply by connecting the channel in question to the Rudder terminal in the Patch Socket, using one of the black link wires. **The Rudder terminal is the only one which works the LEDs, giving it this special test function. Transmitter channels can be checked, ONE AT A TIME, by linking them to the Rudder terminal.**

ALWAYS SWITCH OFF THE POWER WHILST CHANGING THE PATCH SOCKET CONNECTIONS. TAKE GREAT CARE WHEN THE POWER IS ON, BECAUSE DAMAGE TO THE ELECTRONICS CAN EASILY OCCUR IF ANYTHING METAL TOUCHES THE CIRCUIT BOARD OR COMPONENTS.

These LEDs can be used to determine the correct Patch Socket set-up. The procedure we suggest is given below. You will need a pen and paper.

i) Begin by connecting everything up as in Fig. 5-1, **with the exception of the Hoverfly itself, which should not be connected yet.** Switch everything on, and check that the green Signal light illuminates on the ECP. Now switch off the power to the ECP, but leave the transmitter on.

ii) Remove all four link wires from the Patch Socket.

iii) Connect Channel 1 to the Rudder (R) terminal, using one of the link wires.

iv) Switch the power to the ECP on, and wiggle the transmitter joysticks to find out which of the four axes of movement operates the LEDs. Make a note of this. For example, Elevator joystick movement might work the LEDs, in which case note down that Channel 1 is Elevator. If the LEDs do not respond at all, check that the transmitter is set to PPM signalling.

v) Using the table below, check whether the joystick works in the right direction for the Hoverfly. For instance, the Elevator stick should light the red LED when pushed forwards, and the green LED when pulled back. If the direction is incorrect,

change the setting of the transmitter servo reverse switch (for Channel 1 in this example), and try again. Make a note of the correct switch setting.

Stick	Direction	Function	LED
Collective	Forward Backward	Increase Decrease	Red Green
Aileron	Left Right	Left Right	Red Green
Elevator	Forward Back	Nose down Nose up	Red Green
Rudder	Left Right	Left Right	Red Green

vi) Switch off, pull out the Patch Socket link wire and use it to connect Channel 2 to the Rudder terminal. Repeat steps iv) and v) for this channel, then likewise for Channels 3 and 4.

vii) Complete the Patch Socket set-up, using the connections noted above. Insert the four link wires in the required positions, and make a note of the set-up on the diagram below, for future reference.

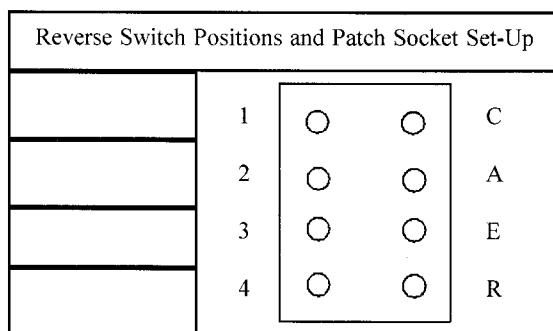

8. SETTING CONTROL TRIMS (NEUTRAL POSITIONS)

The final adjustment required is to set the control trim, so that each function is at neutral when the joysticks are centred. There is a single adjustment inside the ECP for this purpose, which sets the trim for all four channels at the same time. This control is located close to the Patch Socket (Fig. 6-1). On either side of it are two small indicator LEDs, already discussed in Section 7. One of these may be lit. The trim is set as follows:

i) Connect everything up as in Fig. 5-1, **with the exception of the Hoverfly itself, which should not be connected yet.**

ii) Switch on the transmitter and the ECP. The red Power light should come on, followed by the green Signal light.

iii) Centre all the trim tabs on the transmitter. If the transmitter has electronic sub trims, these MUST be set to zero as well, on all four channels.

iv) Use a small screwdriver to adjust the ECP trim control, turning it towards the indicator LED that is lit. At some point the LED will go out, and turning the control further will cause the other LED to light up. Set the control to the centre of the

'dark' zone. Take care not to touch any other components with the screwdriver. If the LEDs do not respond, check the transmitter settings again. PPM SIGNALLING MUST BE USED.

v) Confirm that the ECP is operating correctly by moving the Rudder stick from side to side. Pushing it to the left should turn on the red LED, pushing it right should turn on the green one. If this test fails, then all the connections should be checked carefully, and the set-up procedure done again.

vi) If all is well, switch off the power to the ECP and the transmitter. Since all settings are now complete, the ECP cover should be carefully replaced (Section 14L).

NOTE: Now that the ECP has been trimmed, the transmitter trim tabs can be used as required for fine adjustment of aircraft trim.

NOTE ON OLD OR UNUSUAL TRANSMITTERS:

Although the ECP trim control adjusts the trim on all four channels simultaneously, the LEDs only indicate the setting of the Rudder channel. The trim control affects all channels equally, and hence when the Rudder channel is set correctly, they all are. This scheme does rely on the transmitter channels being well matched; ie. all four transmitter channels should be electrically equal when the transmitter trims are all centred. This is true of all modern transmitters in our Standard list, even the basic models, and is one reason why we recommend them. However, we have noticed that some of the less popular brands can be poor in this regard, resulting in unpredictable control trims prior to take-off. Of course, the trim tabs can be offset from centre to compensate for the errors. However, this is difficult to do until the Hoverfly is in the air, and take-off is difficult if the trims are not set fairly accurately beforehand. If you have an old or unusual transmitter, we strongly suggest the purchase of a basic type from our Standard list. Many dealers will supply one separately, and they are inexpensive. It's well worth it!

You are now ready to try out your Hoverfly for the first time. To do so safely, please follow the commissioning procedure in Section 9.

9. COMMISSIONING

Before attempting to fly the Hoverfly for the first time, it is very important to check that it is operating properly. Incorrect set-ups can cause the Hoverfly to start violently and unexpectedly, so steps i) to iv) of the following procedure are designed to prevent mishap if this should occur. PLEASE FOLLOW THEM CAREFULLY. Steps v) to x) allow you to try out the Hoverfly's controls, and to familiarise yourself with its main features and behaviour, some of which are unique. New pilots should examine Fig. 6-2 (Page 5) carefully, to familiarise themselves with the control layout.

i) Connect up the equipment as in Fig 5-1. Turn on the transmitter, and set all the trim tabs to their central positions. Set the collective stick to the zero position, which will normally be fully towards you. Plug in the power supply, but DO NOT turn on the mains yet.

ii) Pick up the Hoverfly, holding it by the green rotor hub disc, just below the central dome (Photo 1, Page 3). Your grip should feel firm but comfortable. Ensure that nothing lies in the path of the propellers, and be prepared for them to start up suddenly.

iii) Switch on the mains. The gyro will now automatically calibrate itself. The process takes about 3 seconds, and during this period the Hoverfly should not be moved. In normal use this is easy, since it will generally be standing on the floor, but right now it is held in the hand. Therefore, try to keep still just after switching on the power! The gyro can always be reset by switching off the power momentarily.

iv) At power-up, the red light should illuminate on the ECP, followed by the green light after about 2 seconds. The Hoverfly may give a momentary twitch, but if it does more than this, then something is wrong. For example, the collective channel reverse switch could be set the wrong way, in which case the Hoverfly would start at full power! This is the reason for caution the first time it is turned on. If the motors do start up, switch off the power again and check your set-ups carefully.

NOTE: When switching off the Hoverfly, ALWAYS turn off the ECP power before the transmitter. Some transmitters, especially older types, generate a random signal during turn-off. This signal can make the Hoverfly start up momentarily if its power supply is still connected, possibly causing damage.

v) If all seems to be well, it is time to try out the controls a little. While still holding the Hoverfly, slowly advance the collective stick. The main propellers should start to spin, and the tail rotor may also turn. Adjust the rudder trim tab (below the left joystick) to stop the tail rotor for the moment. DO NOT ALLOW THE TAIL ROTOR TO TURN FAST FOR MORE THAN A FEW SECONDS OR MOTOR DAMAGE MAY RESULT. Now keep advancing the collective stick, and notice how the propellers speed up. As they get faster, you will begin to feel their thrust. Advance the collective all the way, listening to the sound created at different settings. You should not, however, let the motors run at full power for longer than about 15 seconds.

vi) Back off the collective until the motors are running slowly. Hold the Hoverfly horizontally, so that the fuselage is free to steer below the rotor. Take care not to grip the black dome, as this is not part of the rotor, and will move with the fuselage. Now move the rudder trim tab to the left a couple of clicks, so that the tail rotor turns slowly. It should be turning counter-clockwise when viewed from the left of the aircraft, and will now be roughly trimmed for flight.

vii) Now try out the rudder control. Move the rudder stick slowly to the left. The tail rotor will speed up, and the Hoverfly will start to steer to the left. If you push the stick further to the left, the rate of steer will increase, all the way to a rapid pirouette. Now centre the stick again. Pushing the stick to the right will have a similar effect, except that the tail rotor will reverse direction, steering the Hoverfly to the right.

viii) Try out the gyro now to see how it works. With the main motors running slowly, gently push the tail boom with one finger, so as the steer the Hoverfly to the right. The gyro will respond, speeding up the tail rotor in an attempt to prevent the aircraft from turning. Pushing the tail the other way will have a similar effect. Push it a little harder, and you will notice quite a firm effort against you. This is how the gyro prevents random

tail movements during flight. The aircraft will tend to remain pointing in one direction, except when steered by a pilot joystick command.

NOTE: *Because the gyro is sensitive, it will detect airframe shake while the Hoverfly is revved-up on the ground. The resulting signals may cause the tail rotor to jitter and stop intermittently before take-off. This is normal.*

ix) Bring the collective back to zero. All the propellers should stop, and the gyro will stop responding. Stand the Hoverfly on the floor in front of you. Advance the collective stick just a little, until the propellers start to rotate. Move it forwards a couple more clicks, and the rotor should start to revolve. Do not advance the collective any further at the moment. The rotor should turn easily, and freewheel a little after you shut off the motors. Now try moving the rudder stick while the Hoverfly is standing on the ground, main motors running slowly. Be careful not to change the collective setting as you move the stick from side to side. You will notice that a very small amount of stick movement causes the tail rotor to run at full speed. This is because the stick movement acts as a *demand signal*, a request to the gyro to make the aircraft steer at the selected rate. The gyro then attempts to obey, by driving the tail rotor progressively harder until it senses that the requested rate of steer has been reached. Because the aircraft is standing on the ground, it cannot move, and hence the gyro tries its best without success!

x) Bring the collective back to zero again. Now pick up the Hoverfly from behind, gripping it by the sides of the black plastic mainframe, immediately above the undercarriage, but below the tail (Photo 2, Page 3). DO NOT try to hold it by the undercarriage itself. Check that the rotor is free to revolve, and that nothing lies in the path of the propellers or tail rotor, then bring up the collective to just above halfway. This is roughly the hover position. When the rotor gets up to speed, which takes about five seconds, you can try out the cyclic (aileron and elevator) controls. These are operated by the right hand joystick (Mode 2). Try pushing this stick in different directions. You should notice the Hoverfly trying to tilt as the cyclic joystick is moved off-centre. At the same time, you will hear an undulating sound from the motors, as the propellers change speed. It is by changing the propeller speeds at different positions around the rotor disc that the Hoverfly creates pitch and roll forces. Once you have familiarised yourself with this control, reduce the collective to zero again, and switch everything off.

NOTE: *To compensate for the effect of gyroscopic precession during flight, the cyclic controls act 90 degrees counter-clockwise in relation to control stick movements. While the helicopter is resting on the ground or held in the hand, it will try to roll to the left when the control stick is pushed forwards, or pitch forwards when the stick is pushed to the right, etc. This is deceiving when trying to test the controls after set-up, since it appears that the elevator and aileron channels are mixed up. THIS IS NOT A MISTAKE, and the controls will operate correctly as soon as the helicopter leaves the ground.*

You are now almost ready to attempt your first flight. However, in accordance with good flying practice, it is important to carry out a few pre-flight checks (Section 10). These should be done before every flight.

Trainer Undercarriage

To aid the stability at take-off and landing two black tubes are supplied for forming a wide undercarriage.

Pass one tube through the hole in the other to form a cross. Attach this to the standard skids using narrow strips of adhesive tape. Excess from the decal stripes is ideal for this. The easiest way to attach the training undercarriage is to stand the Hoverfly on it, and then tape the skids down. The tape doesn't have to wrap all the way round. This is easier than trying to do it with the Hoverfly upside down. It will not affect flight if the training undercarriage isn't perfectly positioned.

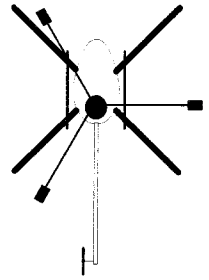

10. PRE-FLIGHT CHECKS

Before any flight, you should do the following:

- a) Check that canopy, undercarriage and tailboom are all seated securely in place, and that the tailfin is vertical. The boom can be gently twisted to correct the latter.
- b) Check that the Hoverfly stands up straight on the ground. If not, gently adjust the undercarriage. If the aircraft stands crooked, it will tend to topple over during take-off. Check that the elevator and aileron trim tabs are centred.
- c) Check that the collective stick is set to zero, then turn on the transmitter, then the power. Allow 3 seconds for the gyro to auto-calibrate. DO NOT MOVE THE HOVERFLY DURING THIS TIME. Now bring up the collective slightly, check that all the motors run, and that the rotor revolves freely. The tail rotor should turn gently, in an anticlockwise direction when viewed from the left of the aircraft. If it is turning too fast, or the wrong way, adjust the rudder trim tab on the transmitter to correct it. The trim tab may have to be a little off-centre. Now move the rudder stick to ensure that the tail rotor responds correctly.

In addition, after maintenance, a crash or a heavy landing, do the following:

- d) Inspect the main motors to ensure they are properly seated in their plastic brackets.
- e) Check that the rotor is seated on the main shaft properly. If it has lifted, take care not to damage the brushes when re-fitting it. See Section 14B for help with this.
- f) Check that the command line (inside the body) is securely plugged in.
- g) Check that the tail rotor retainer boss (the small plastic plug that holds the tail rotor onto the drive pulley) is pushed fully home. This occasionally comes loose in a crash, preventing the tail rotor from being driven properly.

h) Hold the Hoverfly by the rotor hub, and advance the collective a little. Move the rudder stick, and check that the aircraft steers in the correct direction. ***Incorrect steering direction can be caused by incorrect belt fitting, or by plugging in the tail motor electrical connector the wrong way round. A rapid pirouette will result, because the gyro response will reinforce rather than counteract tail movements. It is important to find out about this before attempting to fly!***

Tip: Beginners frequently crash. To facilitate frequent pre-flight checks you may prefer to fly without the canopy fitted. This is satisfactory if the tailboom is pushed 25mm forward in its grommets to correct the balance of the Hoverfly. (Remove the tailboom completely from the chassis before attempting to move the grommets.)

11. YOUR FIRST FLIGHT

If you are a beginner, we strongly recommend that you read the whole of this section before actually flying. If you are an experienced pilot, please read through the next three paragraphs, which outline take-off technique for the Hoverfly.

For your first flights, choose a room with as much unobstructed space as possible. Do not attempt to fly outdoors. Place the Hoverfly on the floor in the centre of the available flying area, and facing away from you. Carry out the **pre-flight checks** (Section 10) if you have not already done so. Position yourself just behind the ECP and make yourself comfortable. After a final check to ensure the command line will not snag on the undercarriage or foul the tail, advance the collective about one quarter. Wait while the rotor gets up speed, then continue to advance the collective slowly, until you notice the Hoverfly becoming light on its skids, and beginning to shake slightly. It is now ready for take-off. Notice the collective setting, which will probably be about halfway up. Note too the distinctive sound of the motors at this point. Always remember to allow time for the rotor to speed up when preparing for take-off. **THIS IS VITAL.** The Hoverfly will blast off instantly if you advance the collective far enough, but it will be unstable and impossible to control until the rotor is up to speed.

If the Hoverfly topples over during the revving-up process, it is a sign that something is not quite adjusted perfectly for take-off. Shut off the collective immediately, and look for the problem. The ECP may be incorrectly trimmed; see Section 8, Setting Control Trims for help with this. Also check that the cyclic trim tabs on the transmitter are centred. Toppling will also be caused if the Hoverfly is standing slightly crooked on its skids. It is important to correct this, by adjusting the seating of the undercarriage in the mainframe. Compressing the undercarriage by pushing the helicopter against the floor will often correct slight crookedness. Any tendency to topple will prevent a vertical take-off, probably causing a new pilot to crash. **DO NOT ATTEMPT TO TAKE OFF UNTIL THE HOVERFLY IS REVVED UP TO SPEED ON THE GROUND.** The training undercarriage greatly reduces toppling before take-off, and we strongly advise beginners to use it (see Section 9 for fitting instructions).

When revved-up and ready, advance the collective smartly to achieve a decisive lift-off. With most transmitters, the Hoverfly will leave the ground when the collective is just above the central position. It will be tempting to linger at this point, trying to hover an inch off the floor so as to prevent damage if you

crash. Even experienced helicopter pilots do this! Unfortunately, because the Hoverfly is so small, it is *much* harder to control when this low, because of ground effect. It will tend to skitter across the floor at high speed, until it bumps into something. Be bolder, and give the collective a burst at take-off to get the aircraft into the air quickly, to a height of at least 12 inches. Control will then be a lot easier. Provided that the Hoverfly was up to speed without toppling over just prior to take-off, it will leave the ground roughly vertically without the use of any controls other than the collective. We strongly recommend using this method to get into the air initially, especially if you are a new pilot. Be ready to reduce the collective almost immediately to prevent the Hoverfly hitting the ceiling! Learning how to take off, reach a safe height and then maintain it requires practice. Fortunately, the Hoverfly is robust, and will withstand a lot of bumping about.

Once in the air, it will immediately become apparent that the Hoverfly will not stay there by itself. In addition to controlling the height, you must learn how to use the rudder control to keep it pointing in the direction you want, which will generally be away from you. At the same time, you also have to learn to use the all-important cyclic controls, which allow you to guide the aircraft in the air or to keep it hovering in one place. Moving the cyclic joystick will cause the Hoverfly to tilt in the direction of stick movement, which in turn will cause it to accelerate in that direction. To keep it hovering, you must learn to use this joystick to compensate for the aircraft's random movements. It is a little like balancing a broom handle on your hand, though somewhat harder to learn. The most common problem is one of too much control, applied too late. This is followed by over-compensation, and so on, which results in a furious oscillation ending in a crash. It is important to learn to apply *small* corrective control inputs in response to changes in aircraft *attitude*. If you wait until the Hoverfly is actually moving before applying correction, it will be too late.

If the Hoverfly is about to crash, it will often minimise damage if you quickly shut off the collective and let the aircraft fall to the floor. However, this reaction does tend to become ingrained, and can be a difficult habit to break later on, causing crashes in situations you would have been able to recover from. When you do crash, check the Hoverfly over carefully (Section 10), **then place it back in the middle of your flying area** before trying again.

The cyclic controls operate in relation to the aircraft itself. This means that the aircraft will tilt towards *its* left when the cyclic joystick is pushed to the left, etc. This gets very confusing when the Hoverfly is facing you, or nose-in. This is why it is important to learn to keep the aircraft pointing away from you as early as possible. Pilots usually learn to fly in this orientation first, before attempting nose-in flight.

Learning to fly will be much easier at the start if you can have an experienced pilot help you. In particular, your helper will be able to trim the Hoverfly accurately, so that the controls are all truly at neutral when the joysticks are centred. The set-up procedure trims the aircraft well enough to fly, but it is only approximate. A well-trimmed aircraft is easier to learn on.

Now practice, practice, and practice. Have fun, and Good Luck!

Note: Balance the rotor for smoother flight - see Section 14E. Care of the command line - Section 14K, and tail maintenance - Section 14F.

12. HELICOPTER PRINCIPLES

Conventional helicopters generate lift by means of the rapidly moving rotor blades. A helicopter can have any number of blades from two upwards, which collectively form the **rotor**. The blades are shaped as aerofoils, and give the machine its name; 'helico', meaning rotary, and 'pter', meaning wing. The blades are set at an angle to the horizontal, so that they create upward thrust as they turn, like a giant propeller. The angle of inclination of the blades is referred to as their **pitch**, and can be changed by the pilot using the helicopter's flight controls. Overall lift is controlled by changing the pitch of all the blades simultaneously. This is referred to as **collective control**, and allows the pilot to cause the aircraft to climb or descend. To maintain a steady altitude, the pilot must set the blades so that the lift they provide exactly matches the helicopter's weight.

Directional control is achieved by varying the pitch of each blade as it travels around its circular path, so that more lift is provided on one half of the rotor disc than on the other. This is referred to as **cyclic control**, and allows the pilot to tilt the aircraft in any desired direction. For example, in order to make the helicopter's nose drop (as if to dive), the pitch of each blade is reduced as it enters the front semicircle, and increased as it enters the rear semicircle. Less lift is then generated at the front than at the rear, causing an imbalance which tilts the whole aircraft. This in turn causes the helicopter to move forwards, because the inclined rotor now provides some thrust in this direction, rather than pulling straight upwards as it did when it was spinning horizontally. This is how a helicopter achieves forward flight. The controls of a helicopter allow the pilot to tilt the aircraft from side to side (**roll**) as well as from front to back (**pitch**, not to be confused with blade pitch!), and any combination of the two, giving total freedom of movement. Constant adjustment of these controls allows the pilot to keep the machine exactly horizontal, and thus to hover. The mechanism that achieves these control functions is complex, and involves numerous mechanical linkages and push-rods, as well as a special tiltable bearing called the **swash-plate**. In the case of models, servos are needed in addition, to provide physical actuation of the control mechanisms.

It is important to realise that a helicopter does not hover or fly by itself, but requires continuous fine adjustment of the controls to maintain stability in the air. The skill required to do this has to be learned, and is fundamental to helicopter flying. However, a helicopter derives a good deal of stability from the rotating blades, which act as a large gyroscope. This slows down its rate of response to a speed at which a human pilot can control it, with practice!

The rotor of a helicopter is generally driven by an engine mounted in the fuselage, by means of a large central drive-shaft. In order to make the rotor turn, the engine has to push against its mountings. This means that the engine is actually trying to turn the helicopter fuselage just as hard as it is turning the rotor itself. This unwanted turning force is referred to as a **torque reaction**. In order to prevent the fuselage from spinning, a helicopter is fitted with a **tail rotor**, which is simply a propeller mounted sideways on the tip of the tail, which pulls against the turning force from the engine. The tail rotor's thrust can be changed, by altering the pitch of its blades. This allows the pilot to steer the aircraft in the horizontal plane, an action referred to as **yaw**. The control has the same effect as a ship's rudder, except that it works even while the aircraft is stationary in the air.

Learning to use this control to keep the helicopter pointing in a desired direction is a further challenge for a new pilot. It has to be done whilst at the same time keeping control over the other axes of movement, which requires great concentration for a beginner. Because the pilot of a model is not actually inside the aircraft, confusion tends to result when the machine is pointing towards him/her. The aircraft's left hand side becomes the pilot's right hand side, and vice versa. The pilot has to be constantly aware of this in order to remain in control.

13. OVERVIEW OF THE HOVERFLY

The Hoverfly uses a radically new approach to generate lift and control, to achieve a flight performance which closely resembles real helicopters and conventional radio controlled models. It is very lightweight, and employs an extremely slow rotor speed, making it comparatively safe, and ideal for indoor operation.

Unlike a conventional helicopter, the Hoverfly uses small rotor-tip propellers to generate its lift. Each propeller is driven by a separate motor, and the main rotor turns only for the sake of stability, driven by the propellers. This approach has a number of advantages over conventional designs:

- 1) The propeller speeds can respond very rapidly to changes in the electrical supply. This allows cyclic control to be provided by changing the propeller speeds at the appropriate moments during each revolution of the main rotor. This is a purely electrical function, not requiring any mechanics; the need for a swash plate and servos is entirely eliminated. The result is an extremely small, lightweight and mechanically simple aircraft.
- 2) A large proportion of the aircraft mass is in the 3 motors, mounted at the rotor tips. This large rotating mass makes the aircraft very stable, even at low rotor speeds. The stability mimics much larger models effectively, while the low rotor speed makes the model safe to operate indoors, and gives a realistic 'scale' appearance in flight.
- 3) The drive that turns the main rotor is provided by the tip mounted propellers, rather than from within the fuselage. There is consequently no torque reaction created, which allows the tail rotor to be very simple and low-powered. The tail rotor provided on the Hoverfly is a fixed-pitch propeller and is needed only for yaw control (steering). It turns in either direction, to allow for both directions of yaw.

14. MAINTENANCE

Numbers in square brackets refer to parts in Fig. 18-1.

A. DISASSEMBLY

1. Pull off the plastic dome [13] from the rotor shaft.

2. Slide the rotor retaining spring [14] off the rotor shaft. This may be quite tight, but it can be levered up from the rotor hub by straddling the shaft just below it with the blades of a small pair of scissors (Photo 3). Twisting the spring against the direction of the coils will also loosen it during withdrawal. Be careful not to lose it!

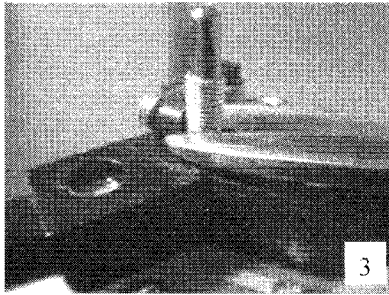

3. Carefully lift off the rotor.

4. The bottom lip of the canopy [12] is pulled in at the front by a plastic strap (Photo 4). This prevents the canopy from lifting off at the front. To remove the canopy, pull it gently off its foam mounting at the top of the mainframe. Lift it over the shaft, and slide it forwards to clear the yaw motor.

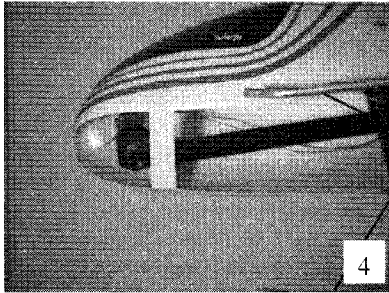

5. Remove the undercarriage [23] by pulling it downwards out of the mainframe [11]. The command line passes through the undercarriage, so it has to be fed along to the end in order to free it.

6. Unplug the lead to the yaw motor [20] (it plugs in at the top of the mainframe, Photo 5).

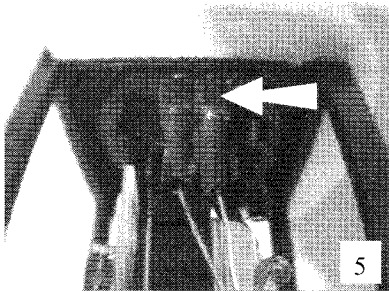

7. Push the boom [25] downwards until the two mounting grommets [24] are released from the mainframe clips (Photo 6). Withdraw the boom carefully, guiding the yaw motor through the mainframe.

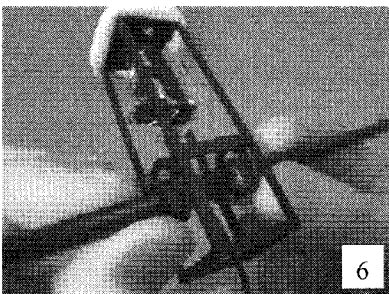

8. Unplug the command line from the mainframe. To do this, carefully pry the three-limbed electrical connector [16] off the pins under the main shaft (Photo 7). Pry up the limbs progressively, so as not to bend the pins. DO NOT pull on the wire or plug stem [17].

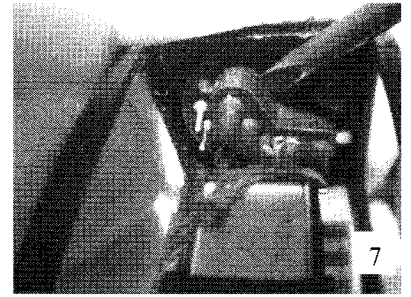

B. REASSEMBLY

This is basically steps 1 to 8 above, in reverse order. Pay attention to the following:-

Step 8. One limb of the command line plug [16] has a flat end. This carries a white spot (Photo 8), which aligns to the white spot on the alignment lug at the edge of the socket.

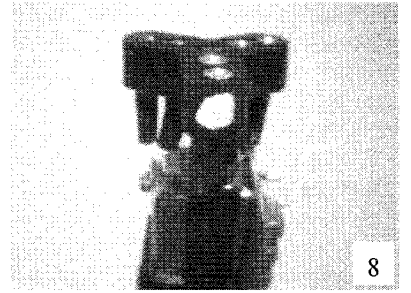

Step 7. Before fitting the boom assembly, ensure the grommets [24] are correctly positioned. They should lie just outside the white rings on the boom. The command line should pass on the right hand side of the boom. Ensure the fin [2] and yaw motor [20] are upright (motor on top of the boom, tail propeller [6] on the left).

Step 6. The yaw motor connector plug carries a white spot, which aligns to the white spot on the socket.

Step 5. When fitting the undercarriage [23], pass the command line through the loop between the crosswires and the right hand skid.

Step 4. When fitting the canopy [12], engage the front first, then ease the top over the shaft and onto the mainframe foam mounting.

Step 3. Fitting the rotor requires some care to ensure that the carbon brushes do not get damaged. Slide the rotor onto the shaft, manoeuvring it so that the three brushes lie against the shaft symmetrically (Photo 9). Ensure that the upper brush is on the correct side of the shaft as the rotor is lowered.

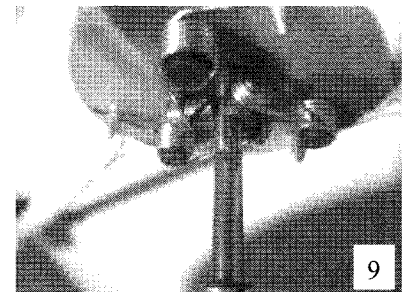

Do not try to force the rotor down until the three brushes have been lifted onto the cylindrical surface of the commutator. Use a small hook (the head of a pin will do) to manoeuvre each brush in to place. Take care not to over-bend the brush wires. When all the brushes are resting on the commutator (Photo 10), allow the rotor to seat fully.

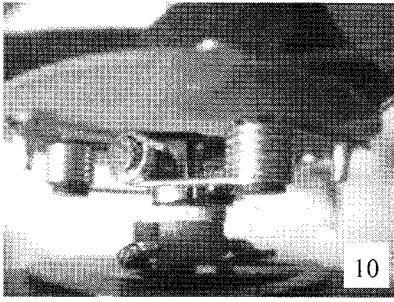

Step 2. Lift the upper brush onto the retaining spring [14] as it is fitted (Photo 11). Do not push the retaining spring too hard onto the top of the rotor. The rotor must turn freely. We recommend about 0.25mm clearance.

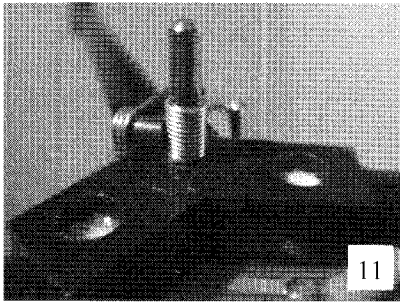

C. MAIN MOTOR REPLACEMENT

Do not attempt to do this unless you are confident of your soldering ability.

1. Unsolder the two wires from the motor terminals using an iron with a small tip.
2. Pull off the push-fit propeller. (See D below)
3. Lift the top of the plastic bracket off the upper motor boss, and ease it over the shaft. Gently prise the base of the motor free from the bracket, and withdraw it upwards.
4. Fitting the motor is the reverse of the above. The outer plastic retaining band can be bent out of the way during motor fitting, then replaced squarely round the side of the motor afterwards. Ensure that the electrical terminal marked MABUCHI is located towards the centre of the rotor. The blue wire connects to this terminal. Carefully re-solder both wires and dress them against the motor bracket. Take care to ensure that the gold wire cannot chafe against the innermost motor terminal, since this will eventually cause an electrical short circuit.

D. PROPELLER REMOVAL AND RE-FITTING

The propellers are a tight push-fit onto the motor shafts. To remove, the motor should be grasped at the sides between thumb and forefingers, so as to clamp the armature, preventing the motor from turning (Photo 12). The propeller can then be twisted back and forth whilst pulling it in order to remove it. Re-fitting is done in much the same way, taking care to offer the propeller up to the motor shaft as

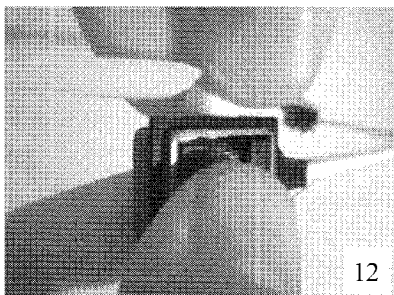

squarely as possible. Take extra care when fitting a new propeller, to hold the motor armature very firmly, otherwise the downward force of fitting can dislodge the lower motor bearing, damaging the motor's plastic back-plate.

Propellers are supplied as matched sets of three, because it is important that they give equal thrust. The packaging carries a single digit thrust number, and all three propellers fitted to the Hoverfly should bear the same number, to prevent flight wobble.

WARNING: THE MOTORS MAY BE HOT AFTER RUNNING FOR SOME TIME.

E. ROTOR BALANCING

Although the Hoverfly comes ready to fly, flight performance can sometimes be improved by fine balancing of the rotor. This will reduce the amount of aircraft 'wobble' experienced during flight, especially at hover. A truly well balanced Hoverfly will fly silky smooth, and is a delight to watch. Wobble caused by crash damage can also be greatly reduced by balancing the rotor. The procedure is straightforward, involving simple trial and error. One of the great features of the Hoverfly is its ability to fly when badly out of balance and trim; this allows for safe experimentation.

The rotor will be balanced by adding small pieces of 'Blu Tac' to the ends of the arms, on a trial and error basis. The correct solution is usually one of two possibilities:

- i) If one of the arms is a bit light, adding weight to it will fix the wobble.
- ii) If one of the arms is a bit heavy, adding weight to the other two arms will fix the wobble.

Some points to note:

- a) You will never need to add weight to all three arms.
- b) When two weights are needed, they can usually be roughly equal.
- c) The level of precision required is not very great. It really isn't hard to make a big difference!
- d) Wobble is actually caused by several interrelated factors, which create a composite effect which is addressed by adding weights. Dynamic imbalance is one of them. However, wobble will also be caused by slight inaccuracies in motor alignment (especially radial slant), distorted rotor geometry (don't let the rotor get wet), and chipped propellers. A wobble sometimes occurs after a rebuild, due to imperfect carbon brush contact. This will generally cure itself after a minute or two in the air.
- e) If you are a beginner, or if you fly wild and crash a lot, it really isn't worth being too fussy. You could buy a second rotor, for special occasions!

The balancing procedure is as follows:

1. With a pencil, number each of the motors for easy identification.
2. Fly the Hoverfly, and note the amount of wobble present.

3. Roll out a small ball of 'Blu Tac', 5-6 mm in diameter. Stick it to the outer edge of motor 1 (Photo 13).

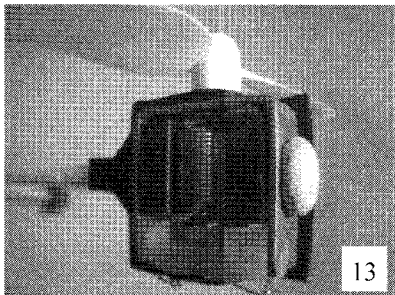

4. Fly the Hoverfly again. Note if the wobble has improved or worsened.

5. If the wobble has worsened, try moving the 'Blu Tac' to motor 2 and try again, etc.

6. If adding weight to any one motor doesn't seem to work, then try weighting pairs of motors in turn. This gives three more possible solutions.

7. Once you have found the right motor(s), you can try different amounts of weight. 5-6mm diameter is a good start, but do experiment.

8. When you are happy with the balance, you can move the 'Blu Tac' to the inside edge of the motor (this will not change the balance noticeably). The plastic bracket has a convenient recess under the rotor arm where it can be hidden.

F. TAIL MAINTENANCE

Although robust, the tail mechanism does require maintenance in order to keep it working well. In-flight tail rotor failures will often lead to a crash; therefore, we recommend the following after every five hours flying time:

1. Remove the undercarriage [23], unplug the lead to the yaw motor (Photo 5, Page 12, this can be reached with the canopy in place, just!), and unclip the tailboom [25] from the mainframe (Photo 6, Page 12). Remove it completely.

2. Using a pointed tool, un-hook the belt [9] from the motor pulley [21], and remove it from the other end.

3. Check that both rear pulleys [4, 8] turn freely. Lubricate each pulley bearing **sparingly**, using a piece of thin wire dipped in light vegetable oil to reach the running surface between each pulley and the bracket [3]. Remove the tail propeller [6] by prising out its retaining plug [7]. Apply a small drop of oil next to the top of the bearing pin [5] inside the propeller mounting turret. Take great care not to let any oil get into the pulley grooves, and carefully remove any that does. The large pulley [4] and the pin on which it runs both eventually become worn, resulting in noisy operation and reduced performance. If the pulley can be wobbled on its pin, these parts should be renewed (Section J). The yaw motor requires no maintenance, and must not be oiled.

4. The belt should be carefully checked for damage and wear. If

it is not in perfect condition, it should be renewed. Re-insert the belt (see G below).

5. Re-assemble the Hoverfly, and test the tail before flying. Especially, ensure that the direction is correct. (See Fig 14-1)

Note: Never run the tail motor without the belt and propeller fitted. Over-revving damage may result.

Tip: After a while, especially in warm conditions, the tailboom may droop. This can be corrected by twisting it through 180 degrees. Having done so, turn the end fittings back again, so that they finish the right way up. Take care to rotate the ends the same way, to avoid twisting the belt.

G. BELT INSERTION

1. Attach the tailboom lightly to a tabletop with tape (or get a helper to hold it). The motor end should be on your left, and the propeller uppermost.

2. Pass the special Belt Insertion Tool into the motor end of the boom, in front of the motor pulley, hooked-end first and uppermost (Fig 14-1). When it comes out of the other end, position the hook just beyond the small pulley, as illustrated.

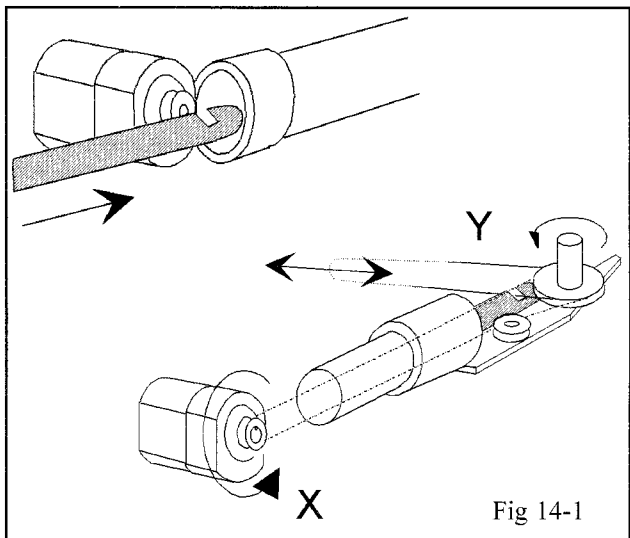

3. Now lay the belt in the groove of the large pulley, drawing it away from you, through the hook in the tool (Photo 14). Hold it loosely extended with your right hand. With your left hand, pull the belt into the boom using the tool, allowing the rubber to run around the small pulley on the way. It will then take up its correct position quite naturally. Keep slight tension on it all the time, letting go with your right hand at the final moment, to allow the belt to drop fully into the large pulley groove.

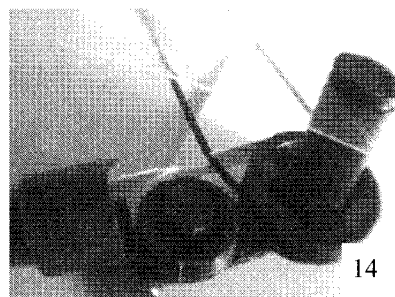

4. When the hook emerges from the left hand end, pull it just beyond the motor, so that the two strands of rubber are drawn

past the pulley side by side. Now lower the belt onto the edge of the pulley, so that the strand furthest from you drops over the rim and down into the groove. Finish wrapping the belt around the pulley in an anticlockwise direction, using the hook to manoeuvre it into place. The belt will now be aligned as in the diagram.

Take care not to twist the belt while pulling it through the tube.

Check that the direction of rotation is correct before flying. See Fig 14-1; turning the motor pulley in direction X should cause the tail pulley to rotate as Y.

H. TAIL PROPELLER REPLACEMENT

Carefully pull out the propeller retaining plug [7] to release the propeller. Press this through the new propeller, and re-insert, pushing it fully home.

I. TAILFIN REPLACEMENT

The fin may be removed by prising off its retaining bar [1].

J. TAIL PULLEY REMOVAL AND RE-FITTING

1. Each rear pulley [4, 8] is held in place by a shaft pin [5], on which it runs. This pin can be seen on the small pulley, but is hidden inside the larger pulley. The pins push-fit into the bracket [3].

2. Remove either pulley by prising it carefully away from the bracket.

3. To re-fit the small pulley, the pin should be pressed into the bracket hole until its tip is flush with the other side. This is easy if the bracket is held against a flat surface.

4. To re-fit the large pulley, the tail rotor must be removed to gain access to the pin. The pin can be pushed with a screwdriver or similar blunt tool. The pin should be pushed in sufficiently to leave no more than 0.25mm clearance between pulley and bracket. The belt insertion tool makes an ideal spacer to get the clearance correct.

K. CARE OF THE COMMAND LINE

The command line is vital to the Hoverfly. It carries no less than 9 separate electrical signals, on 14 thin strands. It is quite robust, but requires care in handling. Please note the following:

1. The two possible failures are broken strands, and short circuits between strands. Both can be caused by careless use.

2. Kinks will weaken the wire. Be very careful to remove all loops when unwinding it, **before** they get pulled tight. Run the wire between thumb and forefingers to straighten it before flying. After use, wind the line onto the spool provided, starting from the Hoverfly end, so that twists can fall out. Alternatively, make a really large spool (30cms or more), to keep twists to a minimum.

3. Be careful to avoid letting the line drag over sharp metal corners, such as electrical equipment cases. This can scrape the insulation from the wires.

4. If the strands separate, twist them together again.

5. Take care to keep the command line from catching in the propellers or rotor. If it gets wound around the rotor shaft, switch off the power **immediately**. Remove the rotor if necessary to untangle the strands from the brushgear.

6. Do not use the Hoverfly if the command line gets wet. Allow it to dry thoroughly first.

7. If a command line short circuit occurs, the ECP will usually switch itself off for protection. To reset it, unplug the power briefly.

L. OPENING AND CLOSING THE ECP CASE

1. The ECP case splits into a top and a bottom section. To separate, hold it by the lower half, and squeeze the sides firmly. The top half will then lift off.

2. To close, offer up the top half squarely, and in line with the bottom. Adjust the two LEDs slightly if necessary to ensure that they engage with the holes in the top. Snap the two halves together gently.

M. GYRO REMOVAL AND INSTALLATION

The gyro is the small electronic circuit board [10] located within the mainframe. The circuit board carries a silver-coloured oblong sensor, which engages in the rectangular plastic frame that forms part of the command line connector stem [17]. The gyro is connected to the command line by a small black plug, which engages with pins on the circuit board. The wiring is thin, and should therefore be treated gently.

Removal

1. Disconnect the Hoverfly from the ECP.

2. Remove the rotor and canopy (Section 14A, steps 1 to 4).

3. Withdraw the gyro rearwards, by easing the silver sensor out of the plastic frame which houses it. A small screwdriver can be used to **gently** prise the sensor out. Take care when removing, not to tug on the wiring.

4. Unplug the connector from the circuit board, to free the gyro.

Installation

1. With the rotor and canopy removed as above, plug the electrical connector onto the three pins on the gyro circuit board (Photo 15). The connector carries a white spot on one side, which must be oriented towards the edge of the circuit board. This faces the left of the aircraft when the gyro is installed. Incorrect connection will not do any damage, but the gyro won't work!

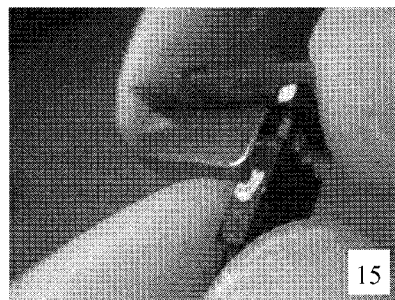

2. Press the silver sensor into the rectangular frame on the command line stem, offering it up from the rear. The electrical connector should be at the bottom (Photo 16).

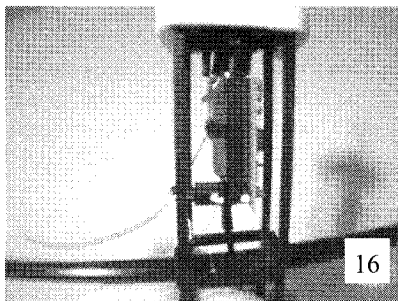

15. FITTING THE WINDOW AND DECALS

1. To fit the window, firstly cut around the moulded outline to remove the excess material.

2. Grooves on the canopy show how to align the window. Hold it in place with a piece of the white tape provided, to create a window frame effect. A neat method is to run a single piece of tape down the centre, from top to bottom, overlapping onto the canopy to hold the window on. The rear corners can be taped down with transparent tape. Excess from the decal sheet is ideal. The window does not need to be taped around the edge.

3. Stripes can be added to the canopy and tail as desired. The tape provided will stretch to turn through tight curves, without peeling off. The picture on the box suggests one possible arrangement for the stripes.

4. The decals can be cut out and applied as desired. They peel and stick, and do not come off easily.

NOTE: *The canopy is most easily decorated by removing it. To avoid the need to disassemble the Hoverfly for this purpose, you may wish to purchase a spare canopy and decorate that, especially if you are a beginner. The decorated canopy can be substituted when you have learnt to fly.*

16. TIPS AND TROUBLESHOOTING

16.1 In-flight wobble and rotor repair.

Section 14E. contains a detailed procedure for balancing the rotor to reduce wobble, which works well in the majority of cases, where the wobble is only cosmetic. If the wobble is bad enough to make flight difficult, then there is probably something else wrong, such as a faulty motor. There are a few other issues worth mentioning.

Firstly, it is important to realise that the propellers come as sets of three, which have been closely matched for thrust. Although moulded, the propellers do vary somewhat in pitch, due to random cooling distortions. To achieve smooth flight, the three propellers must provide equal thrust, and track well during speed changes. Replacement propellers carry a single digit thrust number on their packaging, which allows them to be mixed with other propellers bearing the same number. Adjacent numbered propellers will often mix OK too, but mixing high and low numbered propellers will tend to cause flight wobble. However, mixing thrust numbers can sometimes be used as

a means of *curing* a wobble caused by some other fault, such as a damaged rotor arm. It's worth experimenting.

Crashing can of course damage the rotor, causing wobbly flight afterwards. Sometimes the rotor may look OK, but in fact, one of the arms has been bent out of alignment in the crash. Vertical slant on a rotor arm, where it differs from the others, will especially cause wobble. This can be seen if the rotor is viewed side on whilst fitted to the fuselage. Each arm can be rotated into view in turn, and a careful eye can spot any difference in arm slant. A bent arm can often be straightened again, by bending it from the root where it leaves the hub moulding. The rotor arms are made from very elastic spruce, and extreme care must therefore be taken, since the wood must be forced close to breaking point in order to create a permanent bend. The process will be easier if the outer plastic covering is removed first, by slitting it lengthways with a sharp knife. It can be re-fitted afterwards.

Because of the importance of accurate rotor geometry, we generally recommend replacing a broken rotor, rather than attempting a repair. The bare frame is inexpensive, and can be built up in about half an hour. However, with care, a repair can be done. Arms tend to break close to the root, so that the weight of splints etc. added to strengthen a joint will not affect balance very much. Counterweights can always be added, anyway. It is important when repairing an arm, to get it exactly straight so that the motor is equidistant from the others, and lies in the correct plane. The forward slant of the motor should be 5 degrees (it should be tilted anticlockwise from the vertical when viewed towards the centre of the rotor). The arm should, of course, finish up the same length as the others. The plastic covering can be left off the repaired arm if necessary, without affecting flight performance significantly.

16.2 Adjusting tail performance.

The effectiveness of the tail rotor can be varied by altering the pitch of its blades. This is easily done by adjusting the folds in the plastic propeller, close to the centre. There is no need to remove the propeller to do this, but it is worth making sure that the retaining boss hasn't been loosened during the process. Increasing the blade pitch makes the tail easier to handle, because the gyro's effectiveness is increased. The tail can be made very 'tight' indeed, giving rapid rates of yaw, with very snappy, almost instant stopping. Too much pitch will cause the tail to wag, because the gyro becomes unstable.

16.3 One of the motors won't run.

If one of the main motors won't run, then a fault lies on the rotor. Check the wiring, especially the soldered connections to the motor terminals. Make sure that the gold wire is not chafing against the inner motor terminal. This can lead to a short circuit, causing the motor to stop running. The ECP will usually shut down, too (disconnect the power briefly to reset it). Also check that the rotor itself is properly seated on the main shaft. It can occasionally get forced up during a crash. The carbon brushes on the underside of the hub should rest on the cylindrical surface of the commutator (Photo 10, Page 13). Take care when re-fitting, to lift the brushes onto the commutator surface before pushing the rotor down, otherwise they will be damaged.

Make sure that the motor turns freely. A crash will sometimes dislodge the lower bearing, causing stiffness. It is also possible for a propeller to get forced on hard enough to jam. Another

problem which occasionally arises after a crash is particularly bizarre. The motor can pick up a small fragment of metal from somewhere, which sticks to one of the magnets. It may then get trapped against the armature, jamming it. Turning the motor backwards will bring the culprit into view, when it can be removed with tweezers.

If *each motor* stops as it passes a certain place during revolution, then the fault is electrical, and lies outside the rotor itself. The most likely cause is a loose command line plug, either in the Hoverfly, or at the ECP end. A broken strand in the command line can cause this too, as can a fault in the ECP. If you are unable to trace it, contact Snelflight, and we will be happy to help.

16.4 The tail rotor runs fast all the time.

This problem can have a variety of causes. The first thing to check is that the Hoverfly isn't moved during the 3 second gyro auto-calibration period immediately after power-up. During this time, the gyro zeros itself. It is important that the aircraft doesn't move during this period, otherwise the gyro will not subsequently know what speed stopped is! This causes the gyro to drive the tail rotor when the aircraft is actually stationary, because it thinks that the helicopter is moving. To cure the problem, simply disconnect the power momentarily, then let the Hoverfly stand still for 3 seconds after reconnection.

Having eliminated the gyro problem, the next thing to check is the rudder trim setting. Due to the Yaw Rate Demand system, the tail rotor is very sensitive to small movements of the rudder stick. This makes it sensitive to trim offsets too, which can be caused by slight zero errors in the transmitter or ECP, electronic component tolerances, etc. Having set the ECP trim according to the instructions in Section 8, it may be necessary to offset the transmitter trim tab somewhat in order to bring the tail rotor to the correct idle speed, which should be a gentle anticlockwise rotation, viewed from the left of the aircraft.

If the above methods fail, then the problem may be caused by incorrect transmitter set-ups, such as Throttle to Rudder mixing (Switch this off!) or incorrect channel patching, although generally more than one problem would arise from this. A broken or shorted command line strand can cause the tail rotor to run continuously at full speed, as can plugging in the 3 way gyro connector the wrong way round (see Section 14M). Very occasionally, one of the pins in the command line ECP plug can become bent or broken, causing an electrical disconnection or short circuit.

16.5 The Hoverfly blasts off at full power as soon as it is switched on.

When switching on the power for the first time, or after performing set-up changes, it is important to hold the Hoverfly, grasping it by the rotor hub. This will prevent damage if it should start up unexpectedly. A safe commissioning procedure is described in Section 9. Please do read this! The pre-flight checks in Section 10 take seconds to perform, and are well worth making routine.

The commonest causes of blasting off at power-up are:

i) Setting the transmitter to PCM mode instead of PPM. The ECP cannot interpret PCM signals (there are several different

proprietary systems anyway), but will be fooled into starting because a signal is present. When no signal at all is received, the ECP shuts down. The transmitter **MUST** be set to PPM mode.

ii) Incorrect throttle servo reverse switch setting (in the transmitter). When the stick is set to zero, the power is really on maximum. Refer to Sections 6 and 7 for the set-up procedure.

iii) Incorrect connections in the ECP Patch Socket. For example, the collective may be connected to the rudder stick, which would cause the motors to start up at about half speed, since the rudder stick rests at the centre position.

16.6 The Hoverfly topples over, or skitters off sideways when I try to take off.

To take off vertically, the Hoverfly must be trimmed properly (Section 8), and it must be standing up straight on the ground prior to lift-off (Section 11). The collective should then be brought up gradually, in order to allow the rotor to come up to speed. Just prior to leaving the ground, the Hoverfly will become obviously light on its skids, and will start to shake. It is now that it is most prone to toppling over, but if it doesn't, then it is definitely cleared for take-off! Provided that the ECP has been trimmed correctly, toppling during the revving-up process is usually due to crooked standing. Press the Hoverfly down on its skids firmly, in order to compress the undercarriage. This often corrects crookedness. If not, then it will be necessary to adjust the bends in the undercarriage wires where they exit the mainframe. The skids should be horizontal when viewed from the side, and level with each other when viewed from the front (or rear). Toppling can also be caused by an out-of-balance rotor, or by trying to rev-up too quickly. The training undercarriage is a big help.

Once revved up and ready, increasing the collective a little further will result in a clean take-off. Give enough of a power burst to get the Hoverfly up to a height of 12 inches or so, to clear ground effect. Get it up in the air quickly, so that it has no opportunity to slide along the floor. Leave the other controls alone during the actual lift-off. What happens next is up to the pilot, but the Hoverfly will *take-off* on its own. Do read Section 11, which describes take-off in more detail.

16.7 When I try out the controls, the Aileron and Elevator functions seem to be mixed up.

This is due to the effect of gyroscopic precession. In order to compensate for this in flight, the controls act 90 degrees anticlockwise relative to the direction of cyclic joystick movement. This is deceiving while the aircraft is standing on the ground or held in the hand. If the joystick is pushed forwards, the Hoverfly will roll to the left, and if the stick is pushed to the left, the Hoverfly will pitch backwards, etc. This is perfectly correct, normal operation! The effect is very pronounced on the Hoverfly because the rotor does not tilt in relation to the fuselage, as it does on many helicopters, and because a large proportion of the aircraft's mass is in the rotor (well over 50%). The controls will act normally *as soon* as the Hoverfly leaves the ground, even while in ground effect. If the cyclic controls are operated whilst the Hoverfly is held by the rotor, so that the latter is not turning, then the response from the aircraft will bear no relation to joystick movements at all.

16.8 How can I keep the command line strands from separating?

An excellent way to keep the command line in good shape is to twist it up occasionally using an electric drill. You will need a variable speed type, with a half-inch chuck. The command line ECP plug will fit into this; clamp it very gently. There is no need to disconnect the Hoverfly end. Stretch the wire out straight, and make absolutely certain that there are no kinks in it. Either have a helper hold the Hoverfly, or find a way to wedge it on its side. This will be easier if you remove the rotor. Whatever you do, make sure it really can't move. Tape it to something if necessary.

Now go to the other end and hold the drill so that the command line is *slightly* slack (say 3 inches of droop). Start it running

slowly, in the normal clockwise direction, and gradually build up a bit of speed. Put in about 100 turns of twist. This will take three or four seconds at medium speed. **DO NOT LET THE LINE GO SLACK!** If you do, a hopeless tangle will result. When you have finished, remove the plug from the chuck whilst keeping the wire tight, then allow the plug to spin in your hand so that excess twists can unwind. Only after this should you let the line go slack. If you don't let the excess twists unwind, the wire will double twist when it slackens, creating a tangle.

The command line will behave slightly differently just after twisting. It will seem slightly springier, and less inclined to kink. This effect will gradually fade as the twists loosen up, but you can control the wire's character somewhat by varying the number of twists you put in. It's one more thing to play with!

17. SPECIFICATIONS

Aircraft weight	68 grams
Rotor diameter	284mm measured to motor shafts.
Rotor speed at hover	250 rpm. *
Tip propeller speed at hover	22,000 rpm. *
Power consumption at hover	25W
ECP supply voltage	34V
Signalling system	4 channel PPM (Pulse Position Modulation), 1.52ms centre

* These ratings are approximate.

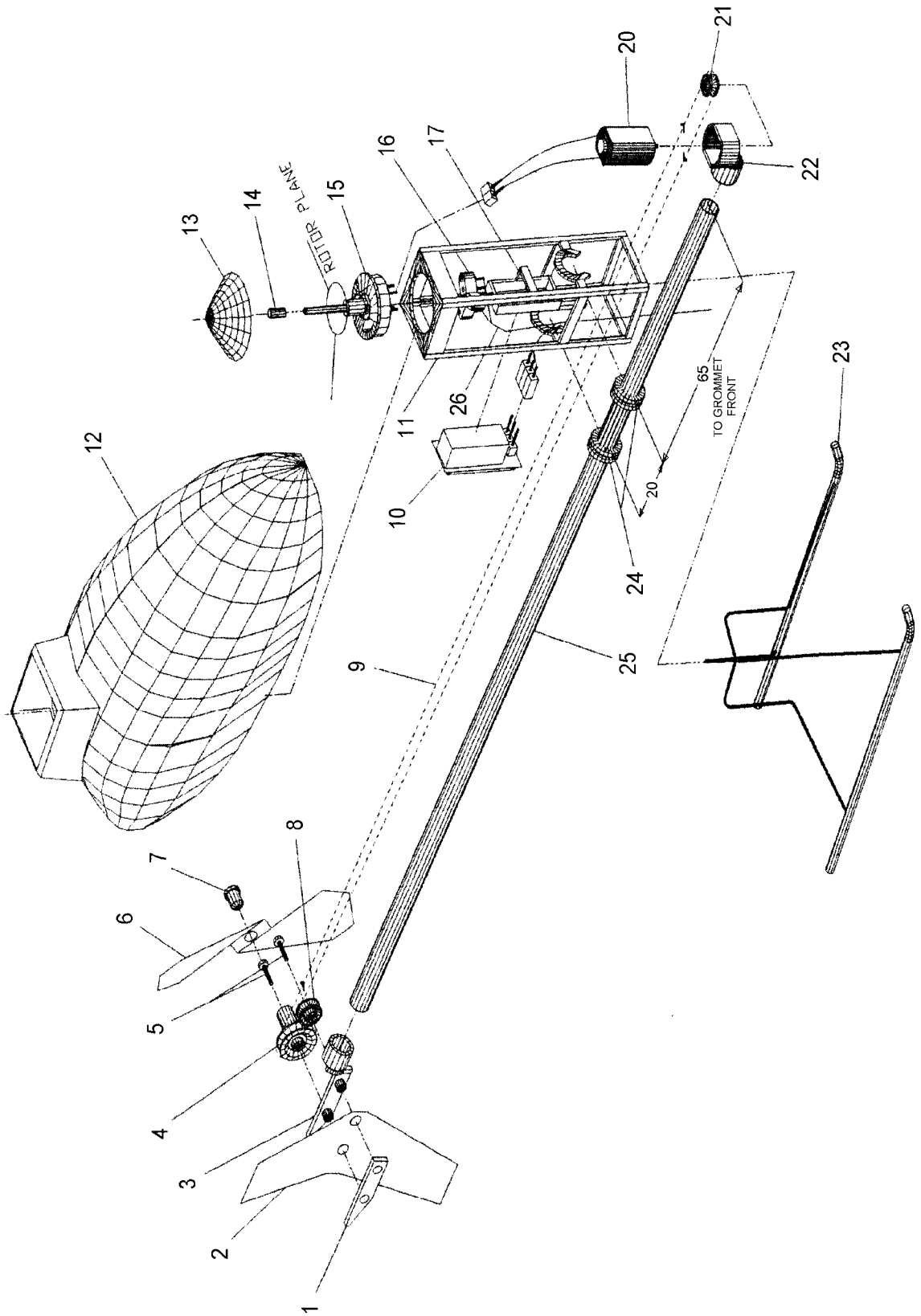

Fig 18-1

18. SPARES

Part No.	Description	Part No.	Description
Fig. 18-1		Fig. 18-1	
ROTOR		OTHER PARTS	
1001	Rotor, complete with motors and propellers	2101	23 Undercarriage
1002	Rotor frame, bare	3001	26 Helicopter command line, 3.5 mtr
1002A	Rotor, less motors / brushes	3001-6	Helicopter command line, 6mtr
4003	Hub PCB, pinned	3002	Signal lead (JR / Sanwa, 3.5mm jack)
7201(4)	Rotor brushes (set of 4)	3003	Signal lead (Futaba / Hitec, 6 way DIN)
5024(3)	Propeller (matched set of 3)	3005	Signal lead (Sanwa, 6 way DIN)
SH030	Main motor	3007	Signal lead (Sanwa RD6000, 5 way DIN)
TAIL BOOM ASSEMBLY		5003	13 Dome cap
1005	Complete assy, with yaw motor	1004	11/15 Mainframe with commutator
3004	20 Yaw motor, with plug	5125	12 Canopy (with brace)
5010	22 Motor bracket	5128	Window
5011	3 Tail bracket	6303(2)	14 Spring collar (rotor retainer) (2)
5012	1 Fin retainer	DECALKIT	Red/white stripes and decals sheet
5013	8 Idler pulley	G100	10 Gyro
5014	21 Motor pulley	PSU-UNI	Power supply
5015	4 Tail pulley	3008	Mains lead, UK
5016(2)	5 Pulley shaft pins (2)	3009	Mains lead, USA
5018	7 Tail rotor retainer	3010	Mains lead, Europe
5019(2)	24 Grommets (2)	ACCESSORIES	
5101	2 Tail fin	5104	Belt Insertion Tool
5102	6 Tail rotor	8205	Command line reel
8202	9 Drive belt	8001	Instructions and Maintenance Manual
BOOM	25 Boom tube, with location marks	CASE1	Carrying case, lined
CONTROL UNIT			
1003	Electrocyclic Control Processor		
7302(4)	Patch link (set of 4)		

For spares, contact your supplier, or in case of difficulty apply to:-

Snelflight Ltd
Churchill House
57 Jubilee Road
Waterlooville
Hants
PO7 7RF

Tel:- 023 92 258999

Fax:- 023 92 251333

E-mail:-

aftersales@snelflight.co.uk