



MANUAL



mini
Titan
E325 3D Heli

➤ **3D PERFORMANCE**

mini Titan E325

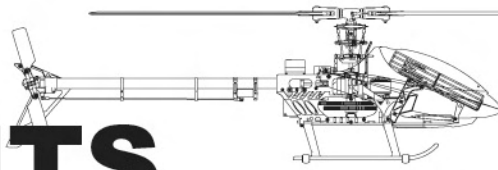

CONTENTS

Introduction	2
Additional Item Needed	4
Assembling section	5
Main Rotor System	6
Linkage Rod installation	12
Main Frame Assembly	13
Tail Unit Assembly	18
Tail Boom Bracket Set	23
Electric System	27
Canopy Assembly	31
Main Rotor Blade Assembly	32
Introduction of E-CCPM control system	33
Servo connecting	36
Concept of basic setting and adjustment	38
Setting up of linkage	42
Trouble shooting	47
Spares Parts	49
Optional parts	57
Heli Accessories	58
Specification and Features	59

INTRODUCTION

Thank you for purchasing the Thunder Tiger Mini Titan-E325 electric R/C helicopter. This new helicopter is the latest innovation by Thunder Tiger. It has the perfect combination of flying stability and the agility for 3D flying. This helicopter is an excellent choice for flying enthusiasts like you. For convenient assembly and safe operation of the helicopter, please read the instructions carefully. Retain the user manual in case you need it for any information or reference.

NOTICE

1. R/C models are not toys. This product is a high-precision flying machine. Possibilities of unexpected crashes may occur due to electronic interference, incorrect operation, or poor mechanical maintenance. Although it is a small sized helicopter, the rotor blades rotate at high speeds, which may cause serious damage, injury, or death if the model hits people or property. Therefore, extreme caution must be exercised during operation.
2. Thunder Tiger ensures parts packaged in this product is of the highest quality. However, after assembly and usage, parts damaged due to wear or misuse will not be replaced under any circumstances. If you have any questions regarding its operation and repair, Thunder Tigers service agents are able to provide free technical guidance.
3. This product is only recommended for users ages 16 and up. Because flying an R/C helicopter is difficult, beginners must receive guidance and supervision from experienced pilots to minimize unexpected danger. Practice in spacious areas, far away from obstacles such as buildings, trees, electrical towers, or crowds.
4. To decrease the cost of repair and maintenance for beginners, we suggested flying the helicopter with a practice rack. It is also recommended to learn basic flying skills with a computer R/C flying simulator. (Crashes in simulators are free to repair!)

AMA INFORMATION

Operating a model helicopter requires a high degree of responsibility and skill. If you are a newcomer to the hobby, it is best to seek help and guidance from accomplished model helicopter pilots. This will greatly speed up the learning process and have you flying successfully in a reasonable amount of time. We also would strongly urge you to join the Academy of Model Aeronautics. The AMA is a non-profit organization that provides its members with a liability insurance plan as well as monthly magazine entitled Model Aviation. All AMA charter aircraft clubs require all pilots to hold a current AMA sporting license prior to operation of their models at club fields. For further information, contact the AMA at:

Academy of Model Aeronautics
5151 East Memorial Drive
Muncie, IN 47302
(317) 287-1256



FLIGHT SAFETY CHECKLIST

1. Make sure that the transmitter battery is fully charged before flying.
2. Make sure all control surfaces function properly before flying.
3. Do a range check of the radio before the first flight. The electronic equipment must operate properly at a range of at least 15 meters (50 ft) even with the transmitter antenna collapsed.
4. Make sure there are no other pilots flying with the same radio frequency yours and that there are no other radio interference on your frequency.
5. Be sure to turn on the transmitter first with the throttle stick in the idle position. Plug the battery into the ESC last.
6. The main rotor and the tail rotor spin at very high RPM. Make sure nothing can come in contact with the rotor blades during flight.
7. Always maintain a safe distance from the helicopter during flight.
8. Never fly the helicopter in the rain or in excessive wind conditions.
9. Always operate and fly the helicopter in a safe and responsible manner.
10. Never fly the helicopter over other pilots, spectators, cars or anything that could result in injury or property damage.

POST FLIGHT INSPECTION

1. Inspect the model thoroughly to insure no parts have come loose or become damaged during the flight and landing. Replace damaged parts and tighten loose screws before flying again.
2. Clean the helicopter body.
3. Lubricate all moving parts to ensure smooth operation for the next flying.
4. Replace any worn ball links and damaged bearings.
5. Store the model in a cool, dry place. Avoid putting it under direct sunlight or near a source of heat.

Following these simple rules will allow you to enjoy the thrill of model helicopter flying for many years.

CAUTION:

When the model has crashed, inspect the flybar, rotor shaft and the blade spindle to make sure they are not bent. If any item is damaged, it must be replaced with a new part to ensure safe operation. Do not glue any broken or damaged plastic parts. Do not repair broken rotor blades. It is very important to inspect the motor, speed controller and the battery.

Always inspect the following items:

Gears, Ball links, Link rods, Bearings, Main shaft, Flybar, Spindle, Tail boom and support, Fins, Tail rotor shaft, Belt, Main blades, tail blades, the motor, the speed controller and the battery.

OTHER ITEMS REQUIRED

RADIO SET

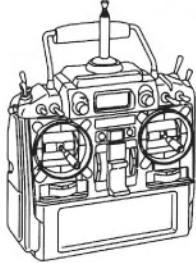

Transmitter
(helicopter type only
6 or more channels)

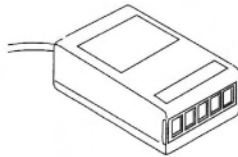

Receiver

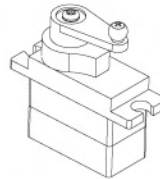

Control Surface x3
Rudder Servo x1

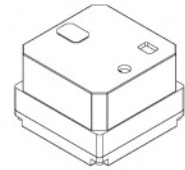

Gyro

POWER SYSTEM



Battery



ESC



Motor



Battery Charger

TOOLS REQUIRED FOR ASSEMBLY

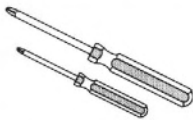

Screw Driver



Needle Nose Pliers



Ball Link Pliers



Nipper

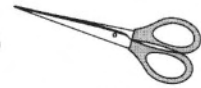

Scissors



Hobby Knife



CA Glue



Anaerobics Retainer



Threadlocking



Grease

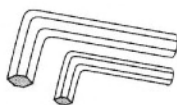

Hex Wrench



Epoxy



Rubber Band

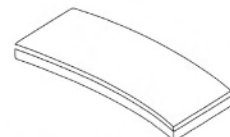

Double Side Tap

ASSEMBLING SECTION

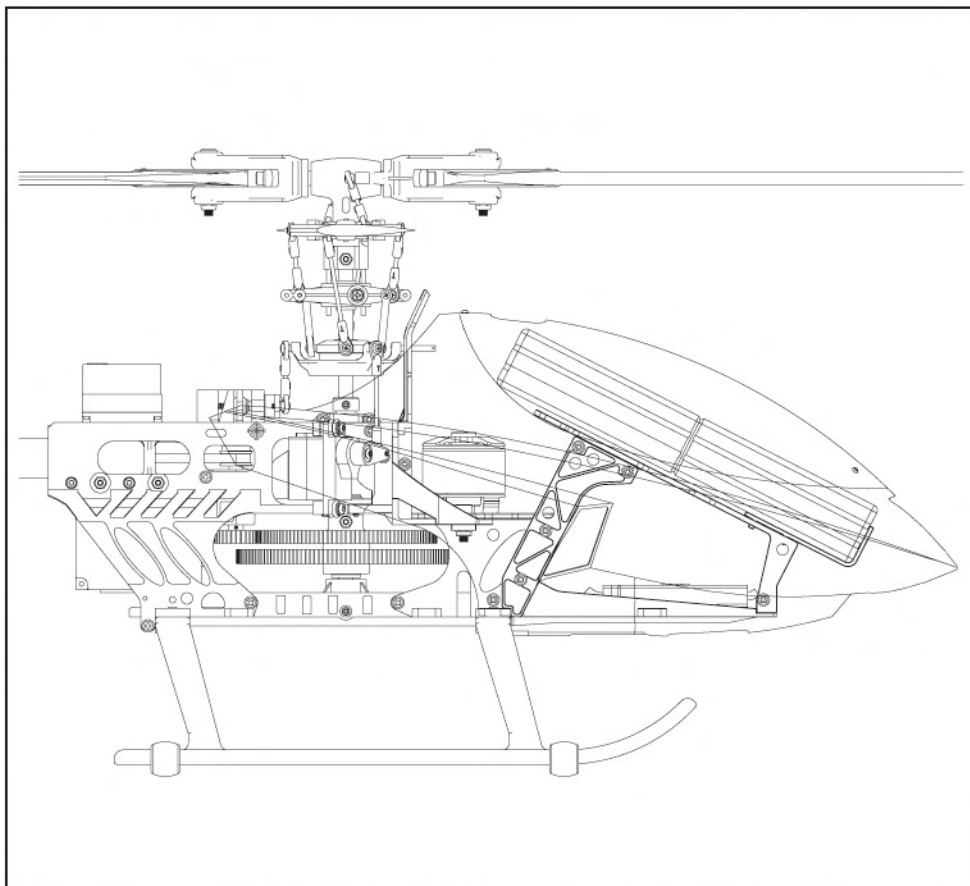

The parts in the mini Titan kit are packed according to the assembly steps. The part number and quantity contained in each are always shown in the square box on each page. Do not open all the bags at once. Open only the bag that is needed for the current assembly step.

Main Rotor-1



No.	Material No.	Description	Qty
1	BV1083	Main Rotor Hub	1
2	BK1045	Seesaw Hub	1

No.	Material No.	Description	Qty
3	HNV2-6Z	Shouldered Screw M2x6	2
4	HMV520ZZW	Bearing d2xD5x2.5	2

Step 1

1. Slide in the Seesaw Hub to the Main Rotor Hub.
2. Mind the direction of the Seesaw Hub.

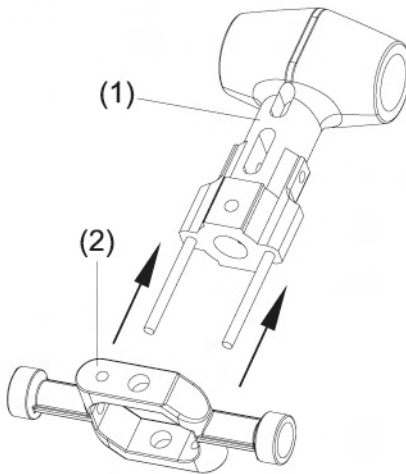

Step 2

1. Turn the Seesaw Hub 90 degrees.
2. Mind the direction of the chamfer.

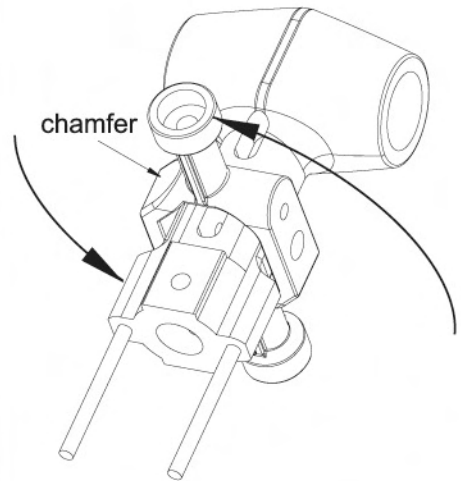

Step 3

1. Fit the screws and the bearings.
2. Do not over tighten the screws and make sure that the Seesaw Hub can be rotated freely.

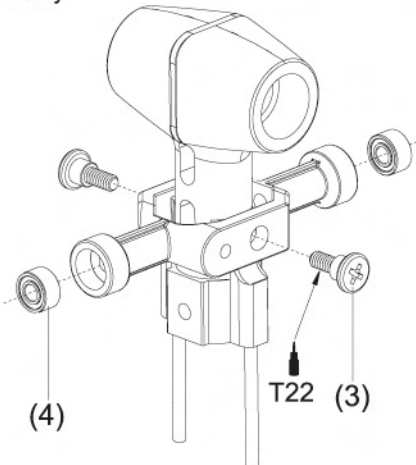

Step 4

Complete

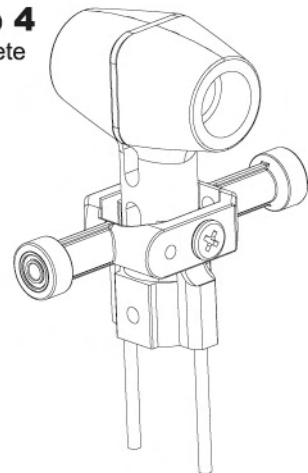

Note

- T22 → THREADLOCKING
- R48 → ANAEROBICS RETAINER

Main Rotor-2



Bag A

No.	Material No.	Description	Qty
1	BK1046	Mixing Lever	2
2	HMV520ZZW	Bearing d2xD5x2.5	4
3	HNU2-9Z	Shouldered Screw M2x9	2

No.	Material No.	Description	Qty
4	BK0920	Flat Washer d2xD3.8x0.2	2
5	BK1203	Linkage Ball (∅ 3.8)	4
6	HSP16-6N	Countersunk Screw M1.6x6	4

Step 1

Secure the Linkage Balls and fit the Bearings to the Mixing Lever.

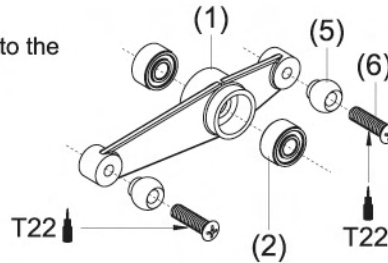

Step 2

1. Secure the Mixing Lever to the Seesaw Hub.
2. Do not over tighten the screws and make sure that the Mixing Lever can be rotated freely.

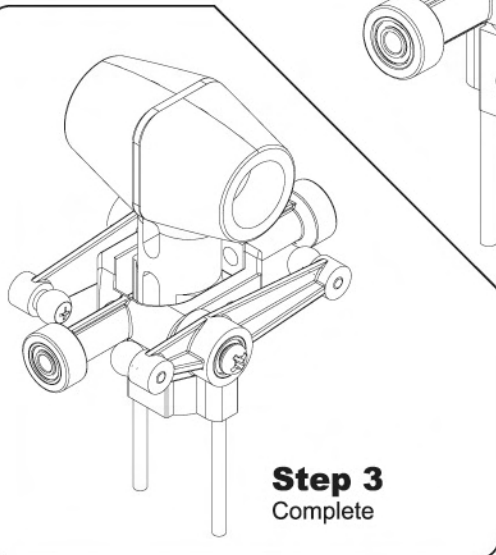
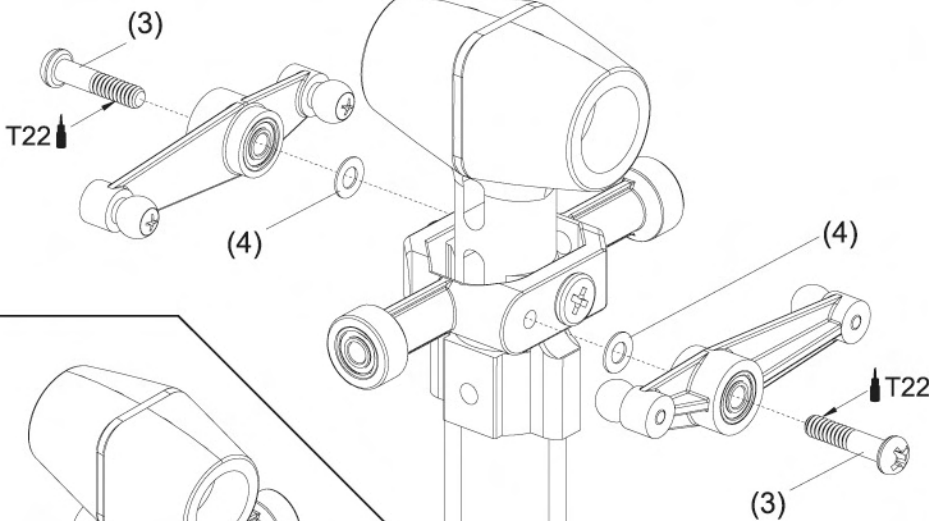

Step 3
Complete

Main Rotor-3



No.	Material No.	Description	Qty
1	BK1044	Collar	2
2	HME3-3B	Set Screw M3x3	2
3	BK1015	Flybar Control arm	1
4	BK0916	Flybar	1

No.	Material No.	Description	Qty
5	BK1203	Linkage Ball (∅3.8)	2
6	HSP16-6N	Countersunk Screw M1.6x6	2
7	BK0941	Flybar Paddle	2

Step 1

1. Secure the Linkage Balls to the Flybar Control Arm.
2. Fit the Collar to the Flybar Control Arm.

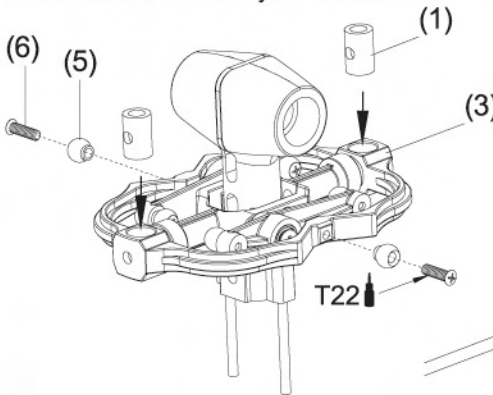

Step 2

1. Slide the Flybar through the Flybar Control Arm and the Seesaw Hub.
2. Make sure the Flybar has equal protruding from each side of the Seesaw Hub of 82.5mm.
3. Secure the Flybar by the Set Screws.

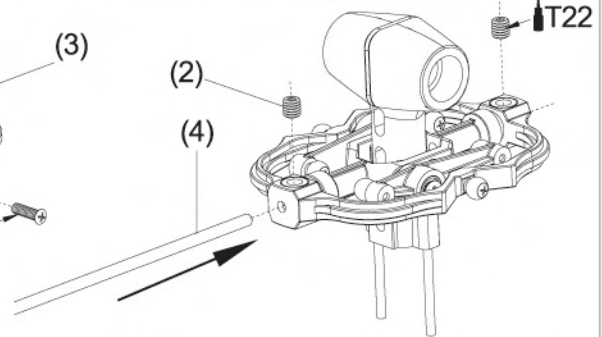

Note:

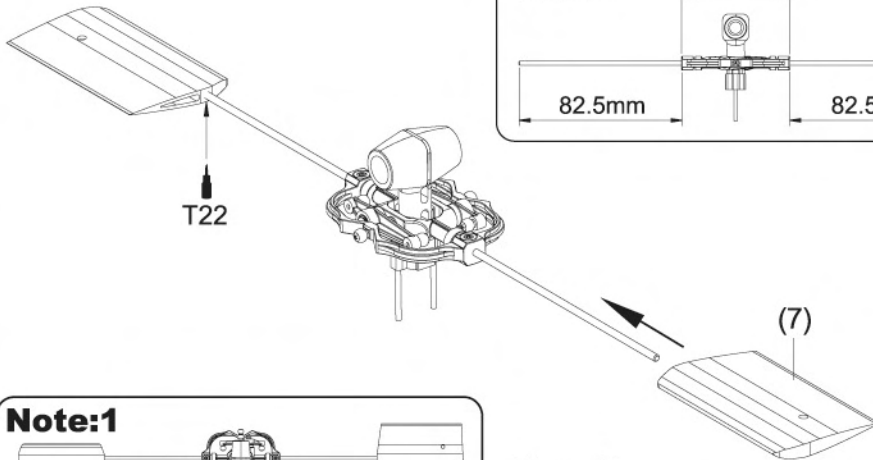
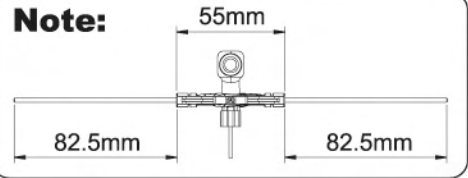

Note:1

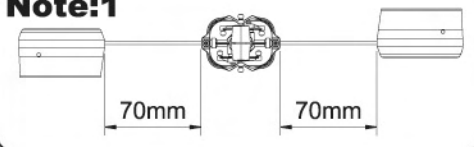

Note:2

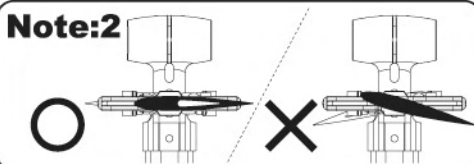

Step 3

1. Secure the Paddles to the Flybar.
2. Make sure that the distance from the Flybar Control Arm to the Paddle are the same in each side.
3. Make sure that the Paddles and the Flybar Control Arm are paralleled. Add some glue between the Paddles and the Flybar to make sure that the Paddles can't be rotated during flying.

Main Rotor-4



Bag B

No.	Material No.	Description	Qty
1	BK1050	Main Rotor Pitch Housing	2
2	BK0906	Feathering shaft	1
3	BK1054	Flap Damper	2
4	BK1079	Collar	4
5	HMX0409	Thrust Bearing d4xD9x4	2
6	HMV940ZZ	Bearing d4xD9x4	2

No.	Material No.	Description	Qty
7	HMV840ZZY	Bearing d4xD8x3	2
8	HMO26	Flat Washer d2.8xD5x0.5	2
9	HMC2610B	Socket Screw M2.6x10	2
10	BK1203	Linkage Ball (Ø3.8)	2
11	HSP16-6N	Countersunk Screw M1.6x6	2

Step 1

1. Secure the Linkage Balls to the Main Rotor Pitch Housing.
2. Insert the Flap Damper in the Main Rotor Hub.
3. Add some Silicon Oil or Vaseline to insert the Feathering Shaft through the Flap Damper.
4. Assemble the Main Rotor Housing and the Bearings one by one as the drawing.
5. Mind the direction of the Thrust Bearings.
6. Be sure to apply Loctite on the M2.6*10 Socket Screws.

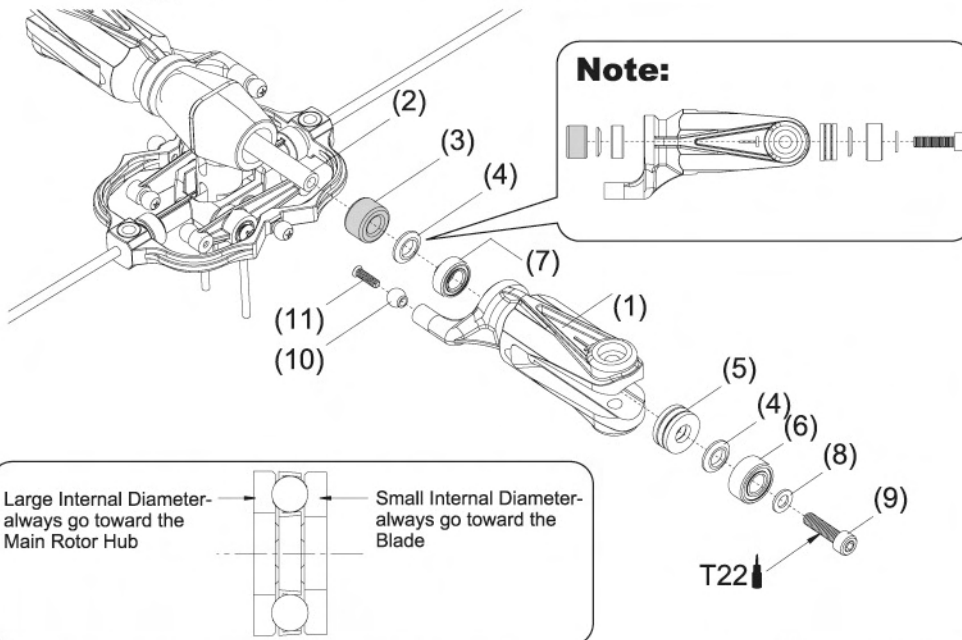
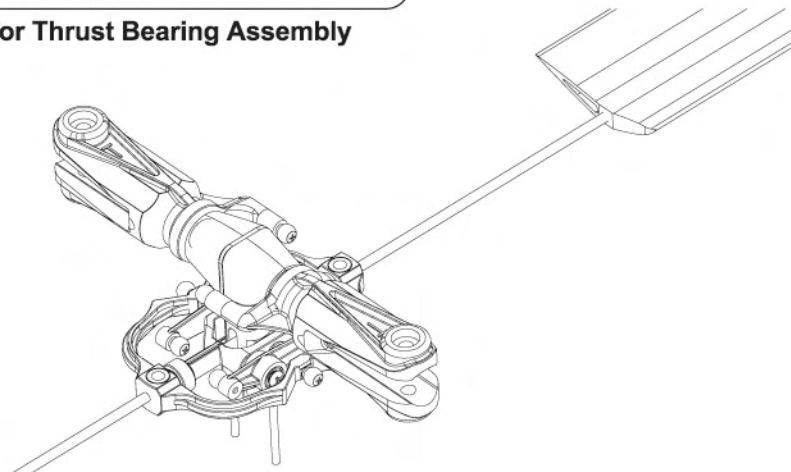

Diagram for Thrust Bearing Assembly

Step 2

Complete



Main Rotor-5



No.	Material No.	Description	Qty
1	BK1051	Main Shaft	1
2	HMC2-14B	Socket Screw M2x14	1
3	HML2	M2 Nut	2

Step 1

1. Slide the Main Rotor Hub Set on to the Main Shaft.
2. Mind the direction of the Main Shaft.
3. Fit the Screw and the Nut to fix the Main Rotor Hub and the Main Shaft.

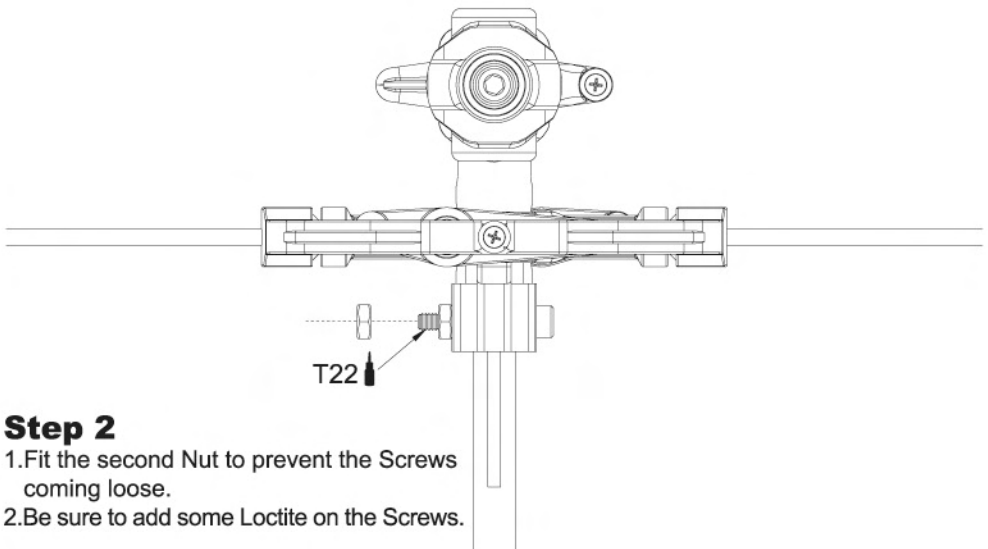
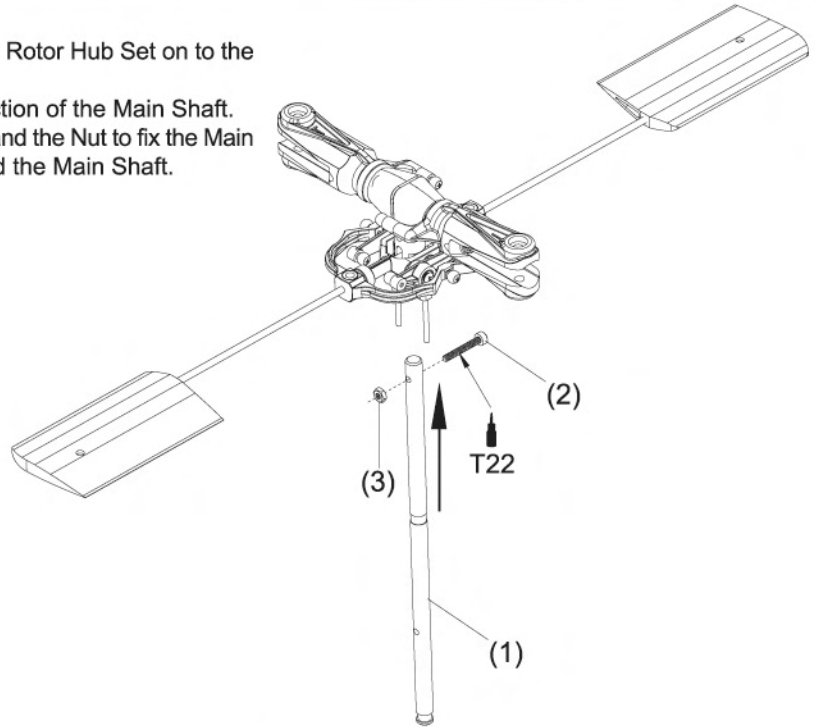

Step 2

1. Fit the second Nut to prevent the Screws coming loose.
2. Be sure to add some Loctite on the Screws.

Main Rotor-6



Bag C

No.	Material No.	Description	Qty	No.	Material No.	Description	Qty
1	BV1010A	Swashplate	1	7	HSP16-6N	Countersunk Screw M1.6x6	2
2	HNU2-9Z	Shouldered Screw M2x9	2	8	BK1020	Main Shaft Lock Ring	1
3	BK1058	Flybar Control Lever	2	9	HME3-3B	Set Screw M3x3	1
4	BK0920	Flat Washer d2xD3.8x0.2	2	10	HMV520ZZW	Bearing d2xD5x2.5	4
5	BK0914	Washout base	1	11	HSP17-7N	Countersunk Screw M1.7x7	2
6	BK1203	Linkage Ball (∅ 3.8)	2	12	BK1014	Washout Linkage	2

Step 1

1. Install the Bearings into the Flybar Control Lever.
2. Secure the Washout Linkage to the Flybar Control Lever and make sure that the Washout Linkage can be rotated freely.
3. Secure the Linkage Balls to the Flybar Control Lever.
The inner hole is for beginner, and the outer hole is for 3D flying.
4. Secure the Flybar Control Lever to the Washout Base.
5. Make sure that the Flybar Control Lever can be rotated freely.

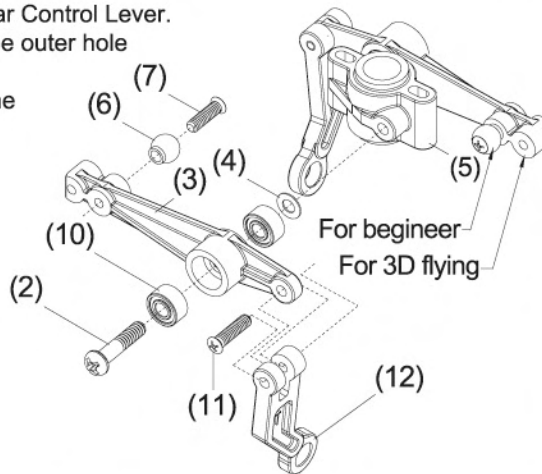

Step 2

1. Slide in the Washout Assembly and make sure the Pins of the Main Rotor Hub can go through the holes of the Washout Base.
2. Then slide in the Swashplate and attach the Washout Linkage to the inner Linkage Balls of the Swashplate.

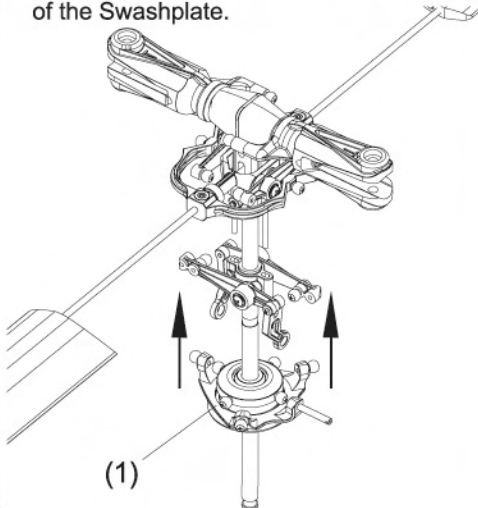

Step 3

1. Slide the Main Shaft Lock Ring and fix it with a Set Screw.
2. Mind the distance from the end of the Main Shaft to the Lock Ring is about 70mm.

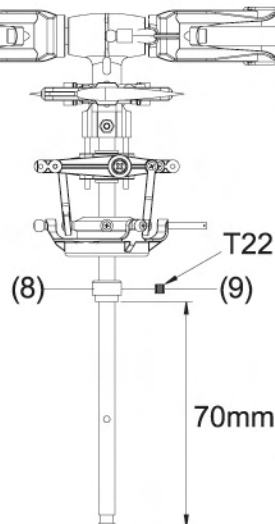

Linkage Rod installation



No.	Material No.	Description	Qty
1	BK0932	Ball Link 3.8x10mm	4
2	BK1063	Linkage Rod 1.3x7mm	3
3	BK0922	Ball Link 3.8x12mm	14

No.	Material No.	Description	Qty
4	BK1064	Linkage Rod 1.3x10mm	2
5	BK1066	Linkage Rod 1.3x24.5mm	2
6	BK1065	Linkage Rod 1.3x29mm	2

Step 1

1. Assemble the Linkage Rods and the Ball Links.
2. The length is measured from the center of the Ball Links to the other.
3. You can use the following 1:1 drawing to measure the length of the rods.

Scale 1:1

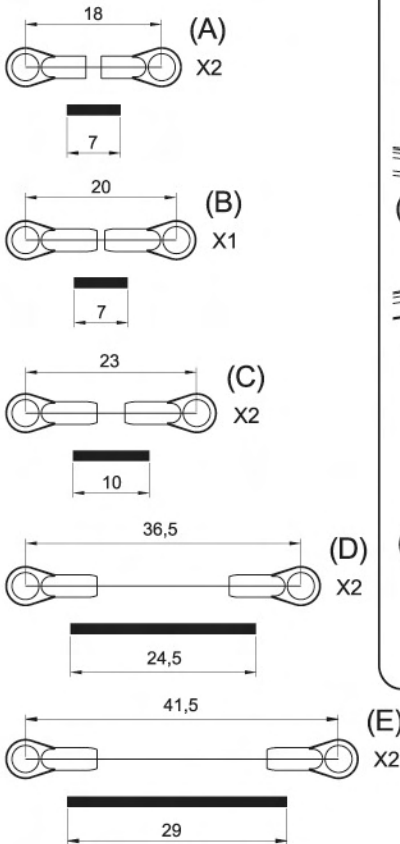

Step 2

1. Attach the rods to the main rotor system.
2. Please refer to the NOTE that the T* on the Ball Link should face out.

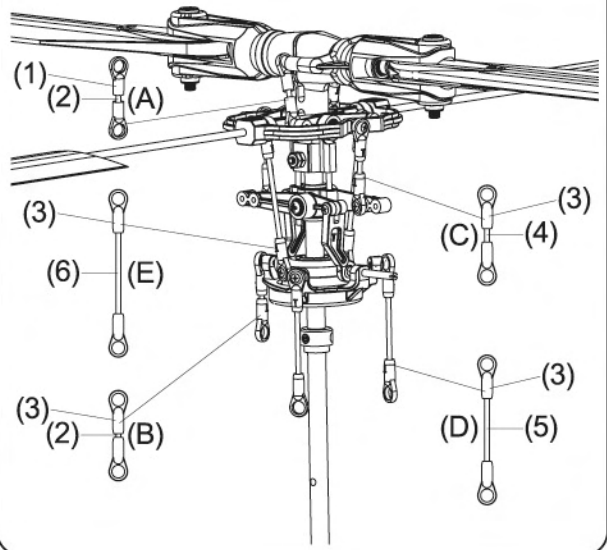

Lengths are measured from ball link center to ball link center.

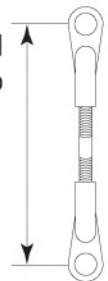

Note:

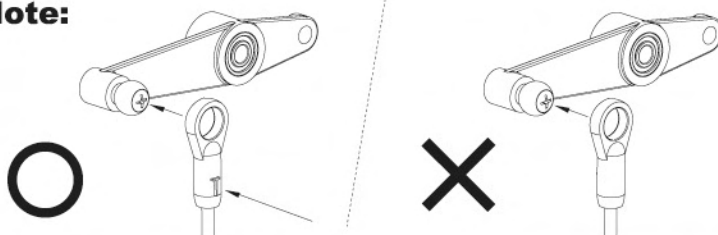

Main Frame Assembly-1



Bag E

No.	Material No.	Description	Qty
1	BK1030	Main frame	1
2	BK1018	Base Plate	1

No.	Material No.	Description	Qty
3	BK1059	Landing Skid	1
4	HNN2-6B	Tapping Screw(W/Washer) M2x6	10

Step 1

Assemble the Main Frame and the Base Plate with 6 self-tapping screws.

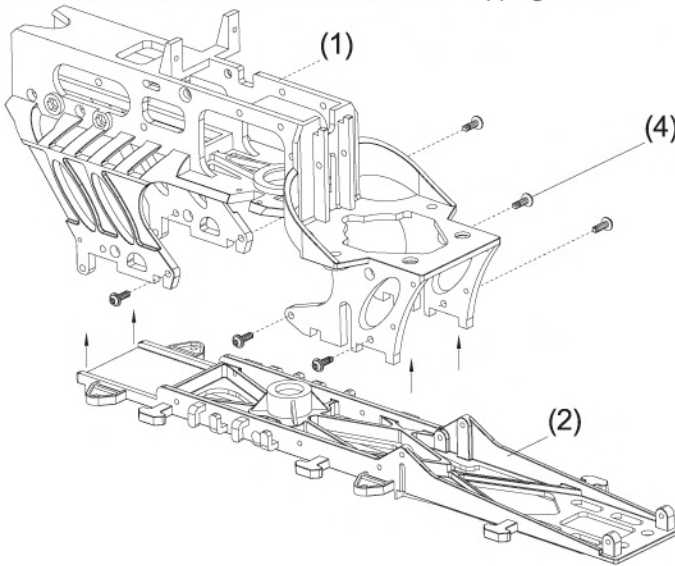

Step 2

Attach the Landing Skid to the Base Plate with 4 self-tapping screws.

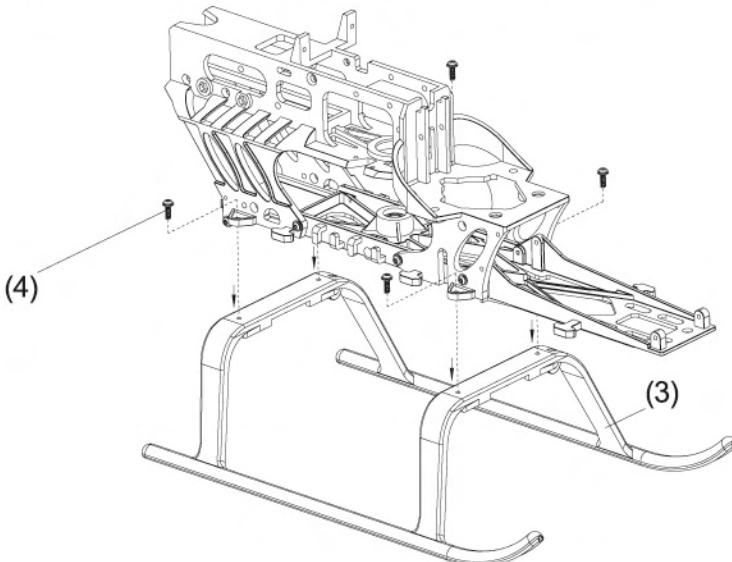

Main Frame Assembly-2



No.	Material No.	Description	Qty
1	HMV1150X	Bearing d5xD11x5t	1
2	BK1034	Upper BRG Housing(left)	1
3	BK1033	Upper BRG Housing(right)	1
4	HNN2-10B	Tapping Screw(W/Washer) M2x10	8

Step 1

Assemble the Upper BRG Housing.

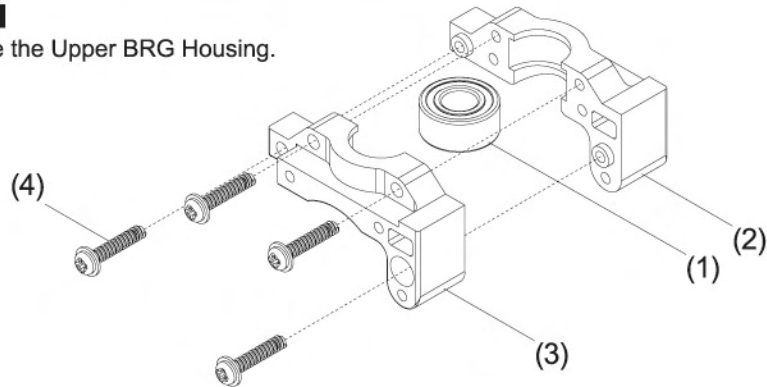

Step 2

1. Slide the Upper BRG Housing into the Main Frame.
2. Fix the Upper BRG Housing with 4 self-tapping screws.

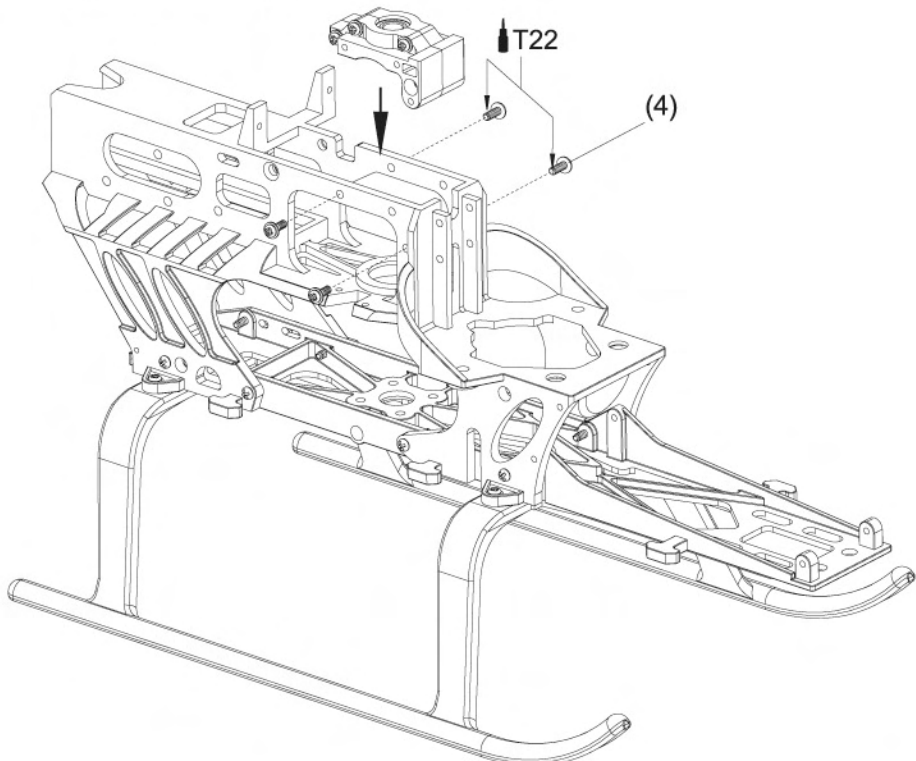

Main Frame Assembly-3



Bag F

No.	Material No.	Description	Qty	No.	Material No.	Description	Qty
1	BK1048	Servo Mount(Right)	1	6	HNN2-6B	Tapping Screw(W/Washer) M2x6	14
2	BK1049	Servo Mount(Left)	1	7	BK1021	Battery Tray	1
3	BK1056	Frame Spacer	1	8	BK1022	Battery Tray Side Plate	2
4	BK1057	Canopy Retaining Post	2	9	BK1023	Battery Holder	1
5	HNN2-10B	Tapping Screw(W/Washer) M2x10	4	10	BK1037	Phasing Control Track	1

Step 1

1. Secure the Servo Tray to the Main Frame with 6 self-tapping screws.
2. Slide the Phasing Control Track onto the Main Frame and fix it with 2 self-tapping screws.
3. Secure the Canopy Retaining Post and the Frame Spacer with super glue.

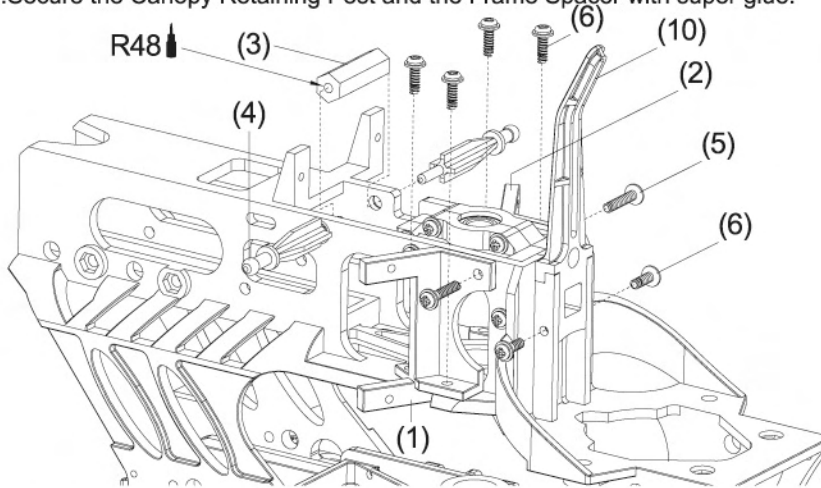

Step 2

1. Attach the Battery Tray Side Frame and secure it with 4 self-tapping screws.
2. Assemble the Battery Tray onto the Base Plate and the Battery Tray Side Frame.
3. The Battery Holder is used to hold the battery when the battery is installed. You can choose the position depending on the size of your battery.

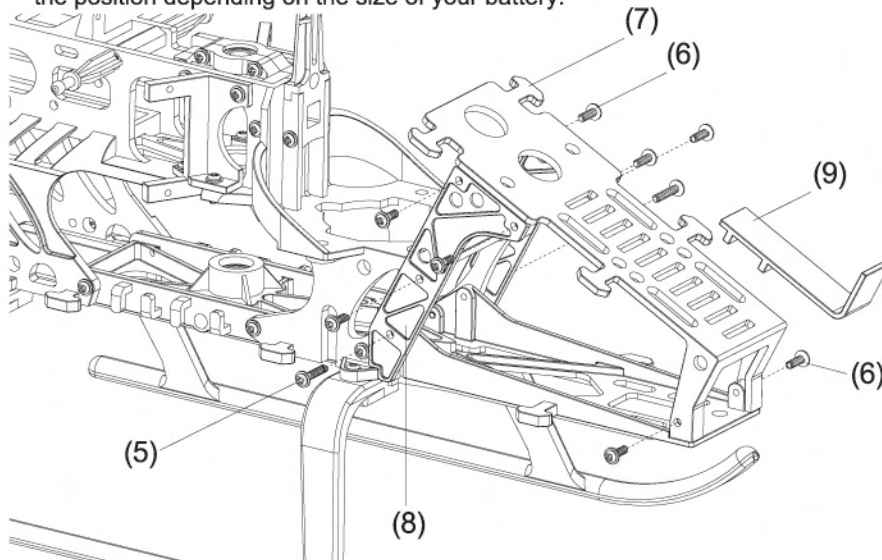

Main Frame Assembly-4



No.	Material No.	Description	Qty
1	BK0933	Autorotation Tail Drive Gear	1
2	BV0934	Main Gear (W/Bearing)	1
3	BK0931	Flat Washer d6xD10x0.3	2
4	BK0930	One Way Bearing Shaft	1

- 1.The One Way Bearing and the Spacer are pre-assembled.
- 2.Assemble the Main Gear and the Autorotation Tail Drive Gear with the One Way Bearing Shaft.

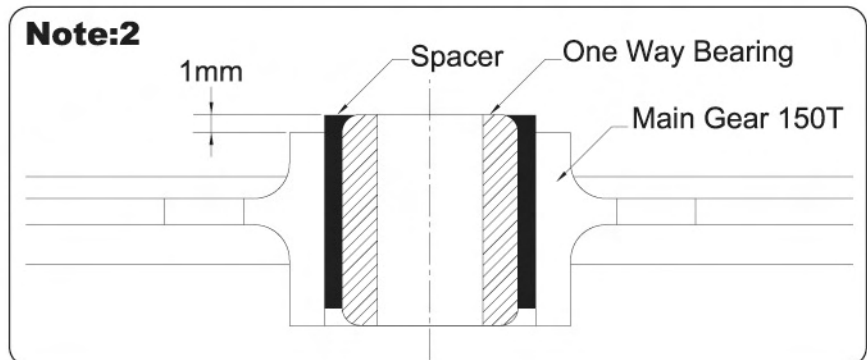
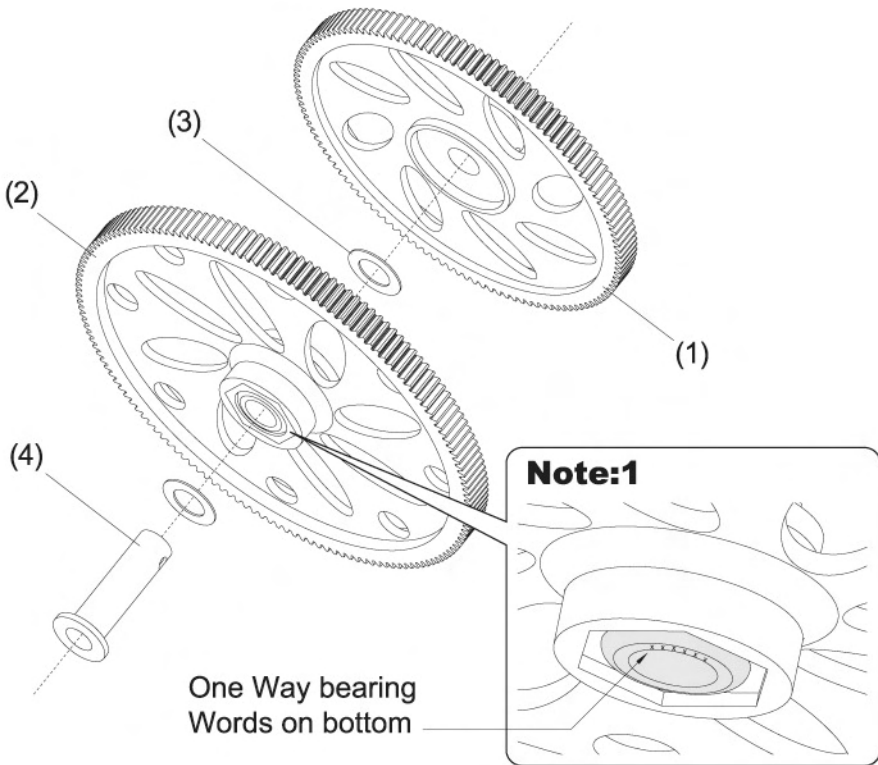

Main Frame Assembly-5

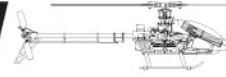

Bag G

No.	Material No.	Description	Qty
1	HMC2-14B	Socket Screw M2x14	1
2	HML2	M2 Nut	1
3	HME3-3B	Set Screw	1
4	HMV1150X	Bearing d5xD11x5	1
5	BK1020	Main Shaft Lock Ring3*3	1

1. Install the Bearing into the Base Plate.
2. Slide the Main Gear Assembly into the Main Frame.
3. Slide the Main Shaft through the Upper BRG Housing, the Main Gear Assembly and the Lower Bearing.
4. Line up the holes of the Autorotation Tail Drive Gear, the One Way bearing Shaft and the Main Shaft. Insert the Socket Screw and fix it with a M2 Nut. Do not forget to add some Loctite and do not over tighten the screw.
5. Push the Main Rotor Hub downward slightly and put on the Main Shaft Lock Ring under the Base Plate. Secure the Main Shaft Lock Ring with a Set Screw through the hole beside the Base Plate. Make sure there is no play of the Main Shaft.

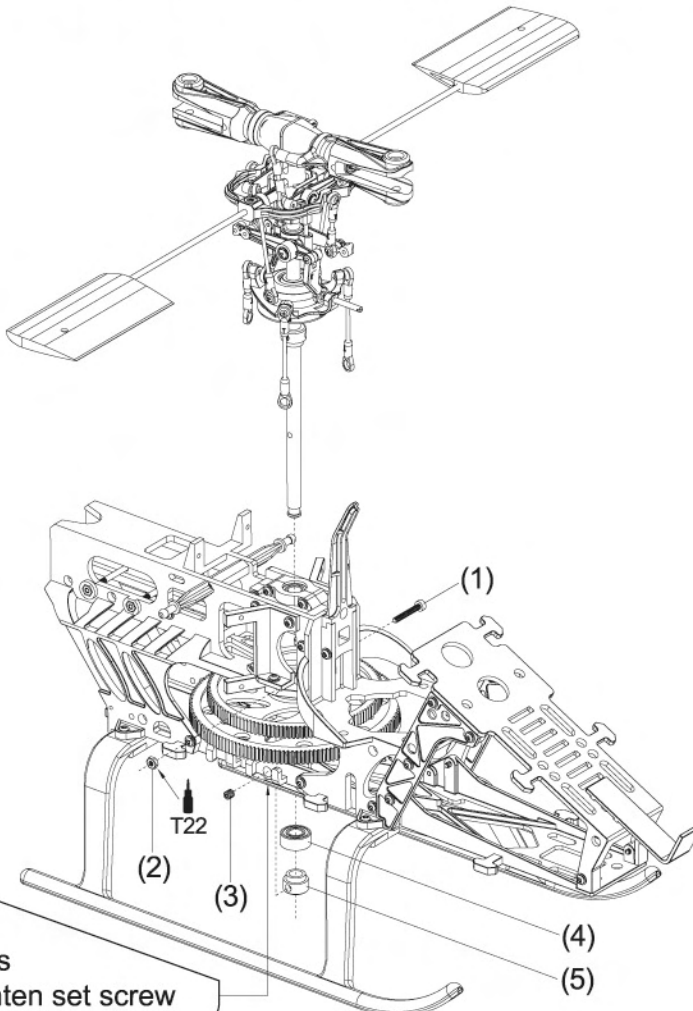

Note:

Use assess hole to tighten set screw

Tail Unit Assembly-1



No.	Material No.	Description	Qty
1	BK1004	Tail Boom 356mmxØ14	1
2	BK1073	Belt MXL-3tx413T	1
3	BK0988	Tail Unit Housing	1
4	BK0989	Tail Unit Housing Cover	1

No.	Material No.	Description	Qty
5	BV0973	Tail Rotor Shaft Set	1
6	HMV830ZZ	Bearing d3xD8x4t	2
7	HNN2-10B	Tapping Screw(W/Washer) M2x10	4

Step 1

Insert the Tail Rotor Drive Belt through the Tail Boom so that it comes out of both ends.

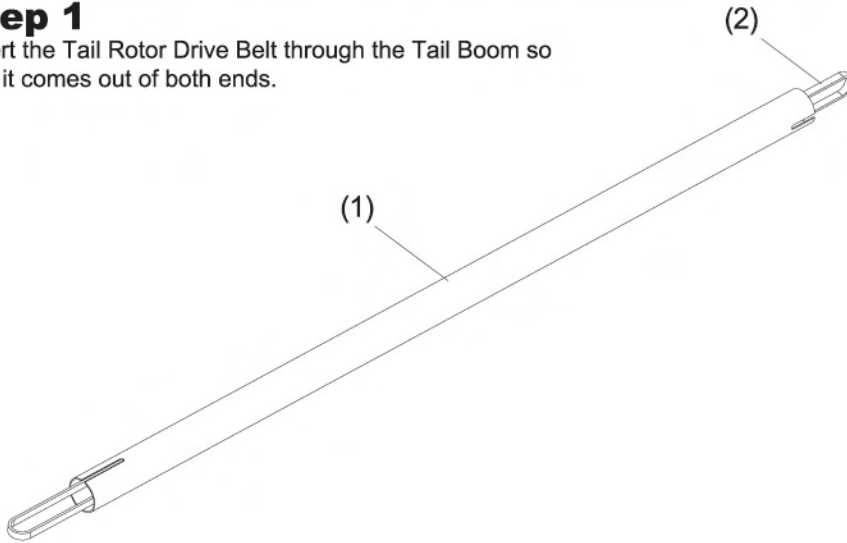

Step 2

1. Install the Bearing into the Tail Unit Housing.
2. Slide the Tail Unit Housing onto the Tail Boom and secure it with a self-tapping screw.
3. Slide the Tail Rotor Shaft Set into the Tail Unit Housing and place the Tail Rotor Drive Belt over the Pulley.
4. Install the Tail Unit Housing Cover as shown.

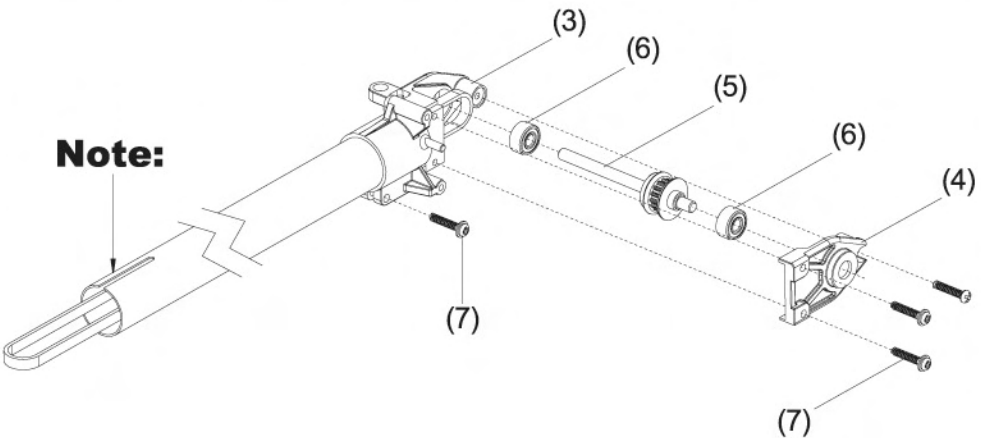

Note:

Tail Unit Assembly-2



Bag H

No.	Material No.	Description	Qty
1	BK0990	Tail Pitch Control Lever-1	1
2	BK0991	Tail Pitch Control Lever-2	1
3	BV0993A	Tail Pitch Control Set	1
4	BK0992	Double Joint Lever	1
5	HMV520ZZW	Bearing d2xD5x2.5	6

No.	Material No.	Description	Qty
6	BK0919	Flat Washer d2xD3.8x0.5t	2
7	HMC2-16B	Socket Screw M2x16	2
8	HNN2-10B	Tapping Screw(W/Washer) M2x10	1
9	BK1203	Linkage Ball(∅3.8)	1
10	HSP16-6N	Countersunk Screw M1.6x6	1

Step 1

1. Fit the Bearings into the Double Joint Lever.
2. Secure the Double Joint Lever to the Tail Unit Housing.
3. Do not over tighten the M2*6 Socket Screw so that the lever can be rotated freely.

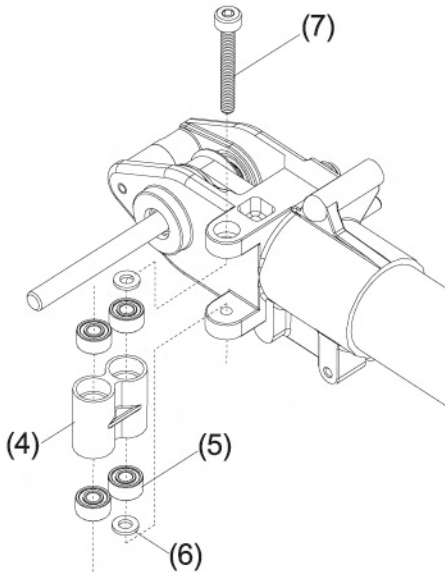

Step 2

1. Secure the Linkage Ball to the Tail Pitch Control Lever-1.
2. Assemble the Tail Pitch Control Levers and the Tail Pitch Control Set.

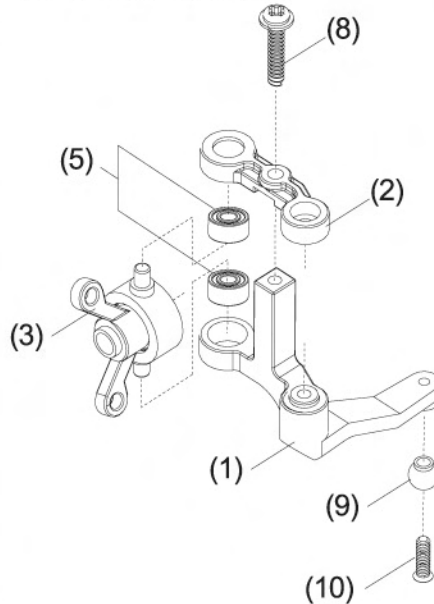

Step 3

Do not over tighten the M2x16 Socket Screw so that the lever can be rotated freely.

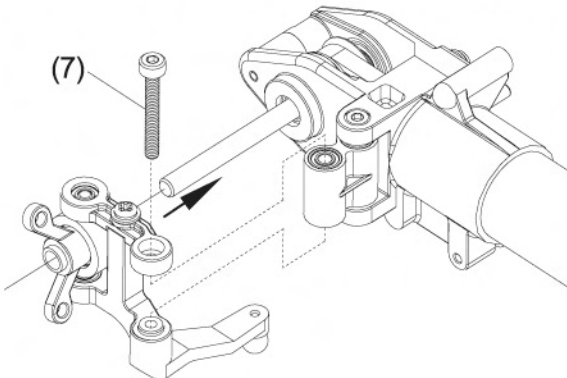

Step 4

Complete

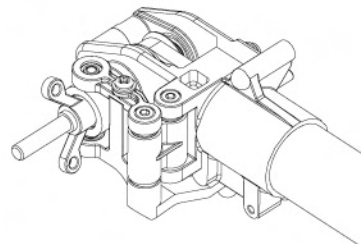

Tail Unit Assembly-3



No.	Material No.	Description	Qty
1	BK0998	Tail Pitch housing	2
2	HMV840ZZY	Bearing d4xD8x3 *4**8*3t	2
3	BK1000	Tail Pitch Control Link	2
4	BK0972	Tail Rotor Hub	1
5	HMV520ZZW	Bearing d2xD5x2.5	2
6	BK1080	Safety Washer	2

No.	Material No.	Description	Qty
7	HMC2-8B	Socket Screw M2x8	2
8	BK0920	Flat Washer d2xD3.8x0.2	4
9	HMC2-10B	Socket Screw M2x10	2
10	HMJ2-10N	Tapping Screw M2x10	2
11	BK0961	Tail Rotor blade	2

Step 1

1. Secure the Tail Pitch Control Link to the Tail Pitch Housing. Mind the direction of the chamfer of the Link. Do not over tighten the screw that the Tail Pitch Control Link can be rotated freely.
2. Assemble the Tail Pitch Housing to the Tail Rotor Hub. Be sure to apply Loctite on the Socket Screw and mind the direction of the Safety Washer.

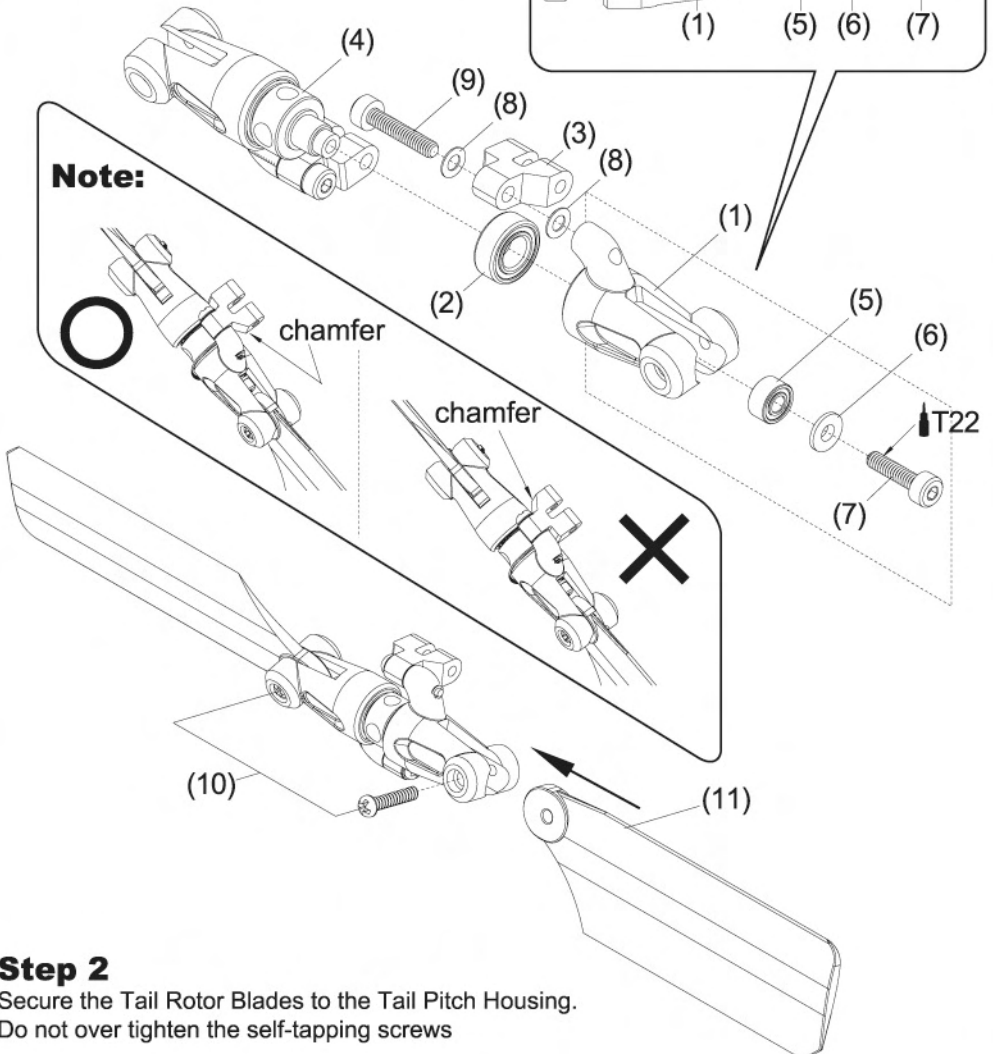
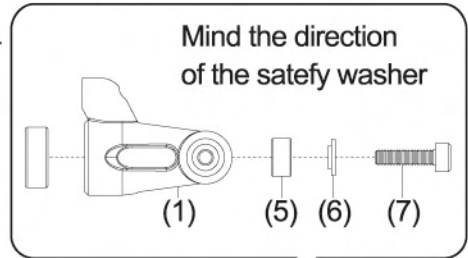

Step 2

- Secure the Tail Rotor Blades to the Tail Pitch Housing. Do not over tighten the self-tapping screws

Tail Unit Assembly-4



Bag I

No.	Material No.	Description	Qty
1	HME3-3B	Set Screw	1
2	HMC2-10B	Socket Screw M2x10	2

Step 1

Secure the Tail Rotor Hub Set onto the Tail Rotor Shaft. Make sure that the Set Screw should be right on the dot of the shaft. Do not forget apply Loctite on the Set Screw.

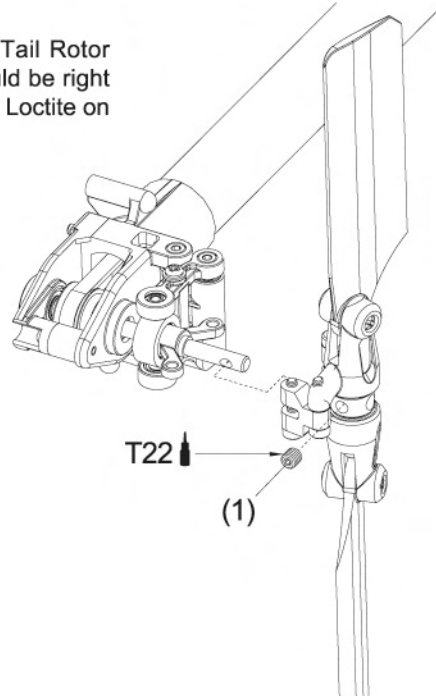

Step 2

Fit the Tail Pitch Control Link to the Tail Pitch Control Set. Do not over tighten the Socket Screw so that the tail linkage can be rotated freely.

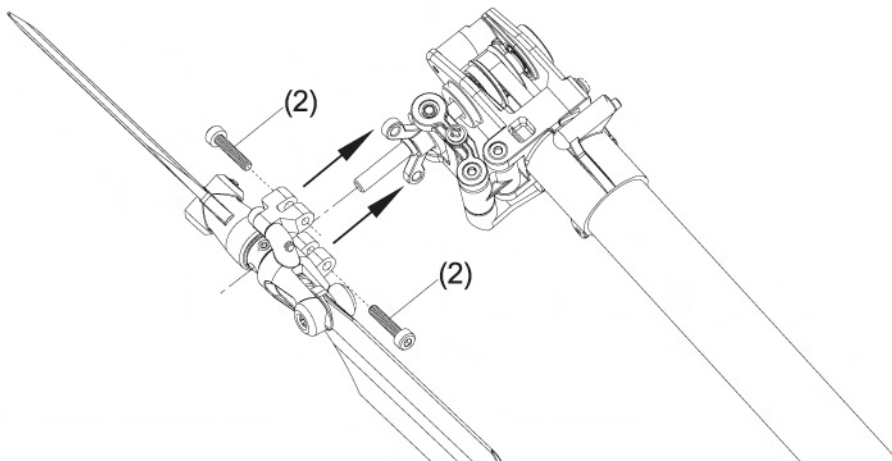

Tail Unit Assembly-5



No.	Material No.	Description	Qty
1	BK1085	Stabilizer Fin	1
2	BK1001	Vertical Fin	1
3	HNN2-6B	Tapping Screw(W/Washer) M2x6	1
4	HNN2-10B	Tapping Screw(W/Washer) M2x10	2

Step 1

1. Secure the Stabilizer Fin to the Vertical Fin.
2. Secure the Vertical Fin to the Tail Unit Housing.

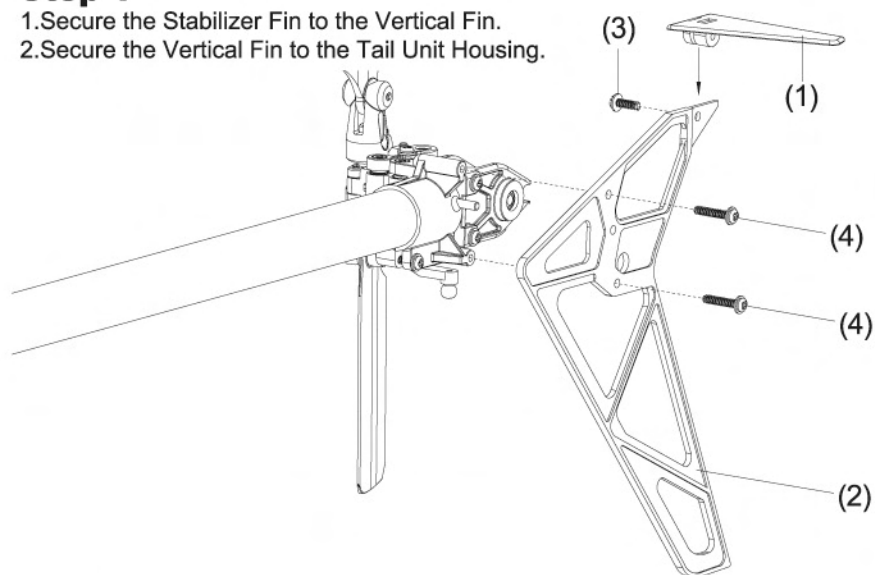

Step 2

Complete

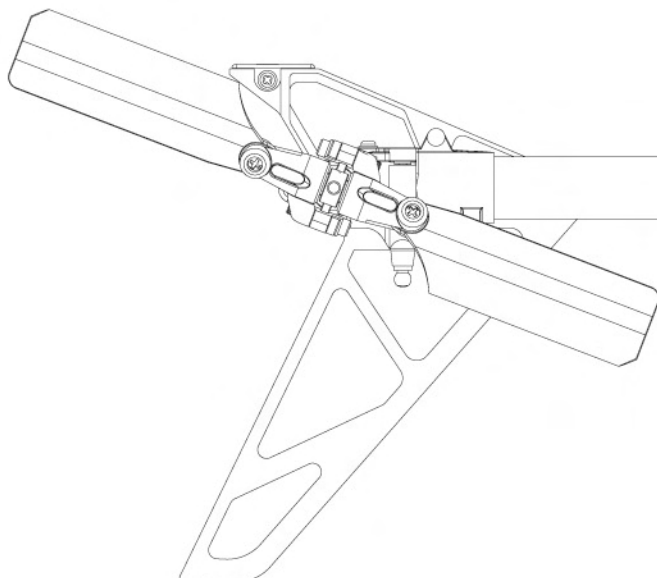

Tail Boom Bracket Set-1

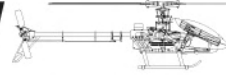

Bag J

No.	Material No.	Description	Qty
1	BK1005	Tail Boom Bracket	1
2	BV1007	Tail Drive Gear Set	1
3	BK1006	Tail Boom Bracket Cover	1
4	HMJ2-10N	Tapping Screw M2x10	2

Step 1

1. Fit the Tail Drive Gear Set to the Tail Boom Bracket.
2. Secure the Tail Boom Bracket Cover to the Tail Boom Bracket.

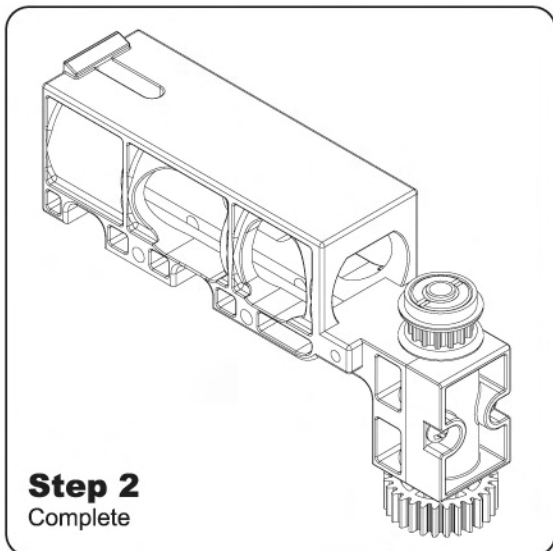
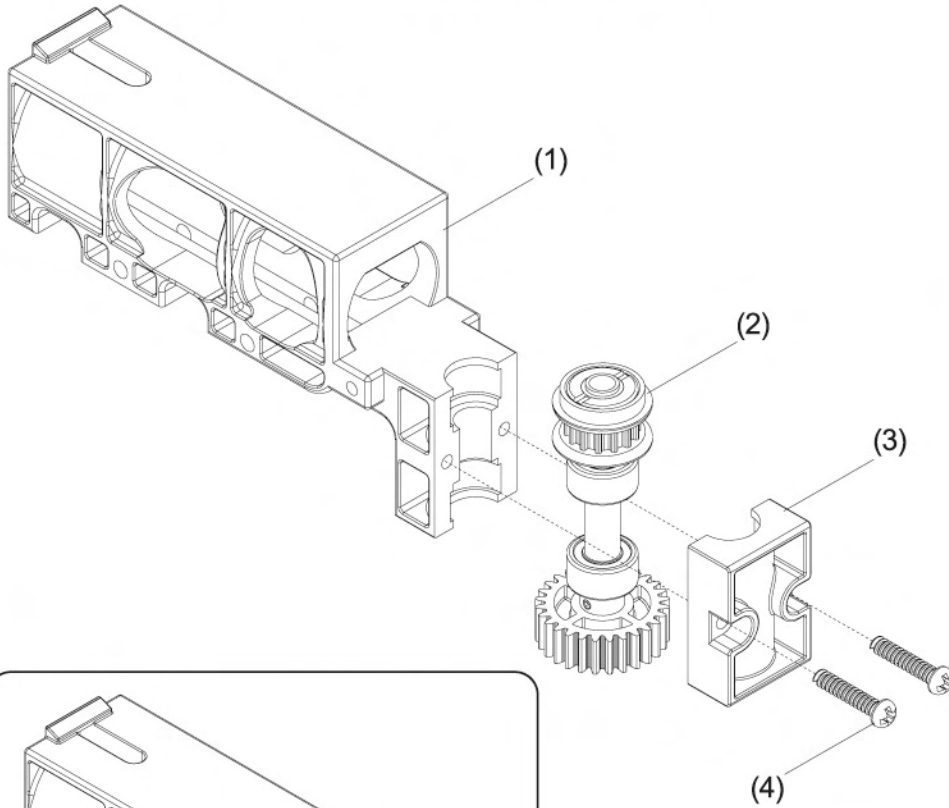

Tail Boom Bracket Set-2



No.	Material No.	Description	Qty
1	HMC2-10B	Socket Screw M2x10	2
2	HML2	M2 Nut	2

Step 1

1. Pull the belt through the Tail Boom Bracket and keep the belt correctly aligned.
2. Push the Tail Boom into the Tail Boom Bracket and the Tail Drive Belt must be rotated as shown below.

Note:

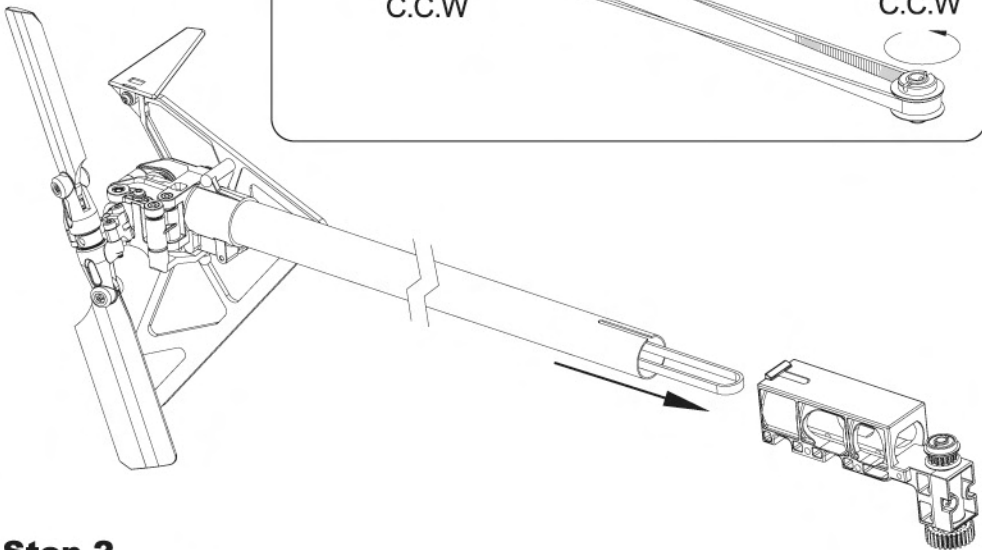
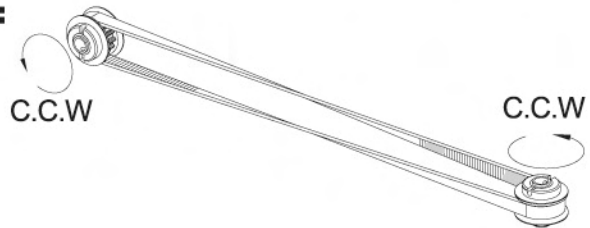

Step 2

1. Place the belt over the Pulley and gently pull back the Tail Boom until the tension of the belt allows no more than 5mm of free play.
2. Fix the Tail Boom in the bracket with the Socket Screws and M2 nuts. Do not forget to apply Loctite on the screws.
3. It is recommended to add a drop of CA glue in the crack on top of the bracket.

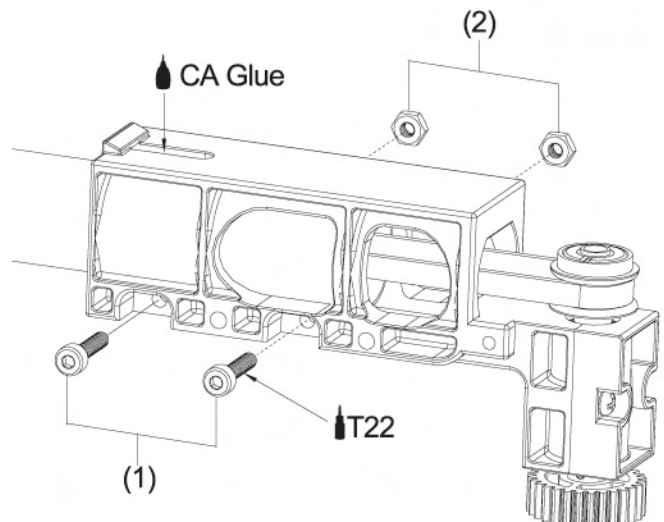

Tail Boom Bracket Set-3

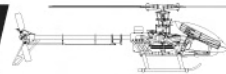

Bag J

No.	Material No.	Description	Qty
1	BK1082	Rod Guide	2
2	HMJ12-6B	Tapping Screw M1.2x6	2
3	BK0923	Tail Servo Tray	2
4	HNN2-10B	Tapping Screw(W/Washer) M2x10	2

Step 1

1. Install the Rod Guides and the Tail Servo Tray.
2. Secure the self-tapping screws but not tighten them at this moment so that you can adjust later.

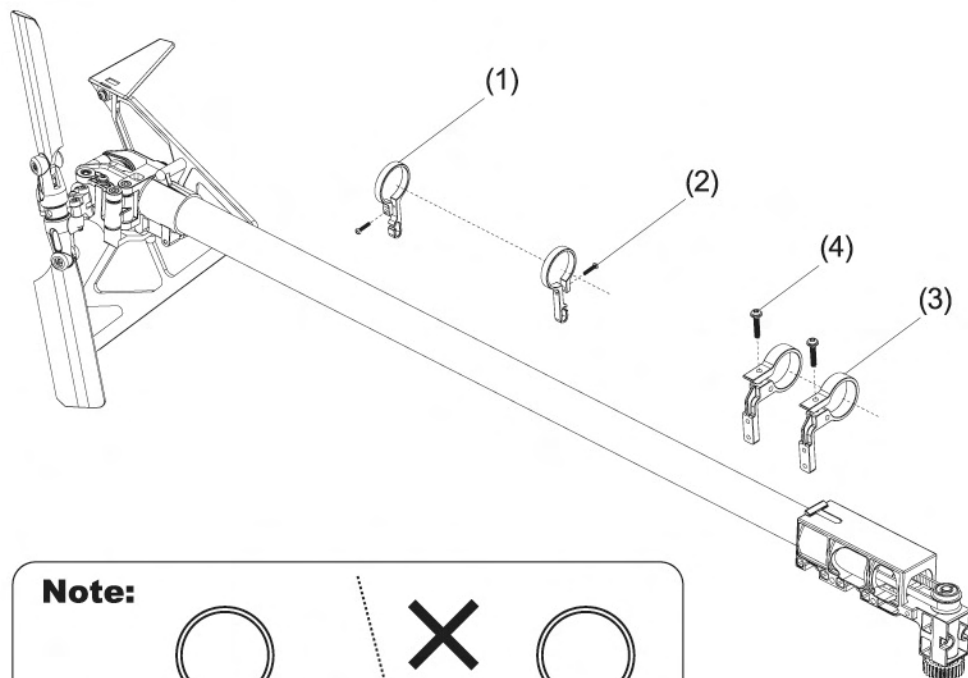

Note:

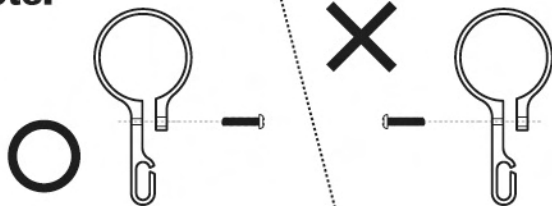

Tail Boom Bracket Set-4



No.	Material No.	Description	Qty	No.	Material No.	Description	Qty
1	HNN2-10B	Tapping Screw(W/Washer) M2x10	4	4	BV1027	Tail support Rod	2
2	HMC2-25B	Socket Screw M2x25	2	5	BK1026	Bracket	1
3	HML2	M2 Nut	3	6	HMC2-14B	Socket Screw M2x14	1

Step 1

- 1.Slide the Tail Boom Set into the Main Frame.
- 2.Push it on the bracket instead of pushing the Tail Boom.
- 3.Secure the Tail Boom Set and do not forget to add Loctite on the screws.

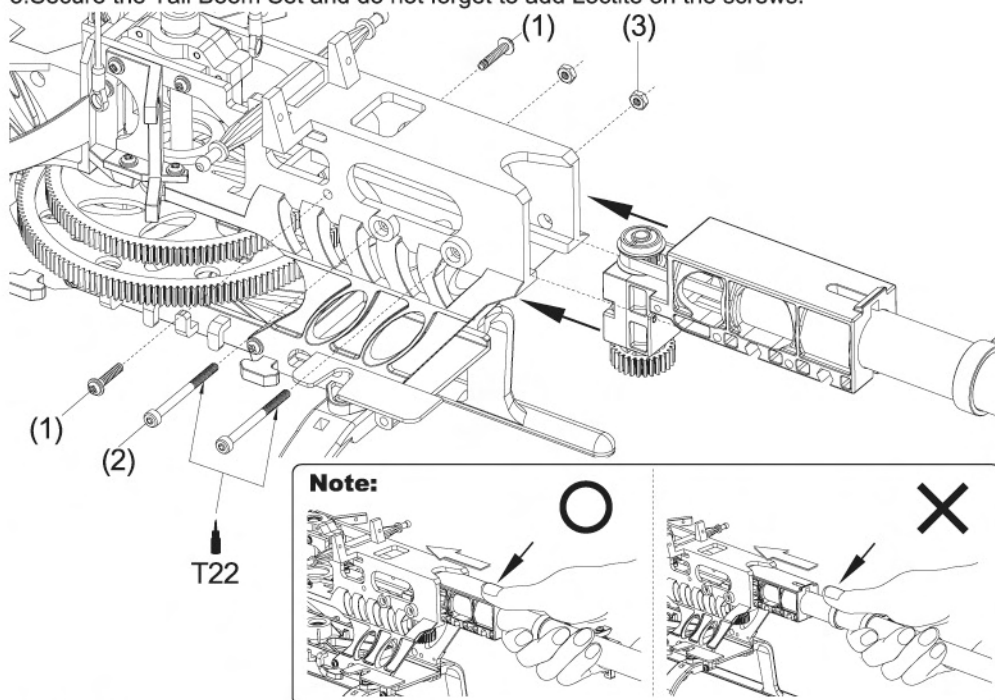

Step 2

- 1.Apply CA or Epoxy when assembling the Tail Support Rod End.
- 2.Install the Tail Support Bracket and fit the Tail Support Rod.

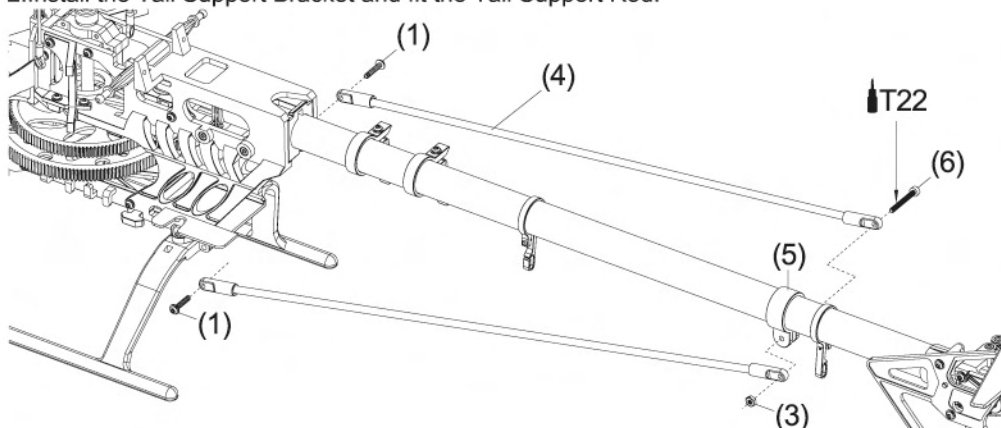

Electric System-1

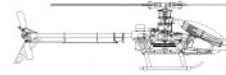

Bag K

No.	Material No.	Description	Qty
1	BK1036	Motor mount	1
2	HSA3-5B	Socket Screw M3x5	2
3	HME3-3B	Set Screw M3*3	3
4	BK1009	Drive Gear 13T	1

No.	Material No.	Description	Qty
5	BK1013	Drive Gear 10T	1
6	BK1016	Drive Gear 15T	1
7	HMC3-10B	Socket Screw M3x10	2
8	HMM3Z	M3 Nylon nut	2

Step 1

1. Mount the motor to the Motor Mount.
2. Secure the Drive Gear to the motor shaft. Note that the distance from the end of the Drive Gear to the Motor Mount should be around 16mm as shown.

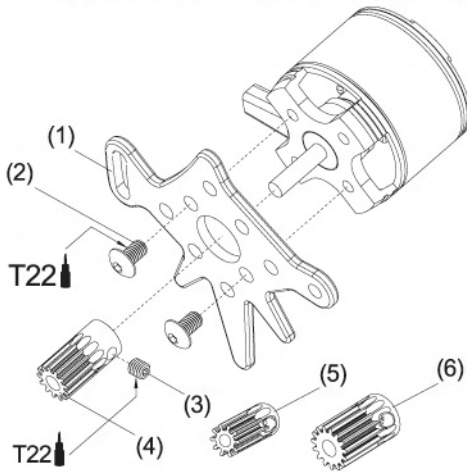

Note:1

1. The OBL 29/35-10H(No.2381) Brushless Motor and 13T pinion are recommended for mini Titan E325 with ACE POWER 3S1P Li-Po battery.
2. The OBL 29/35-10H(No.2381) Brushless Motor and 15T pinion are recommended for mini Titan E325 with ACE POWER 2S1P Li-Po battery.

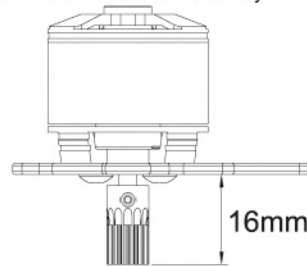

Note:2

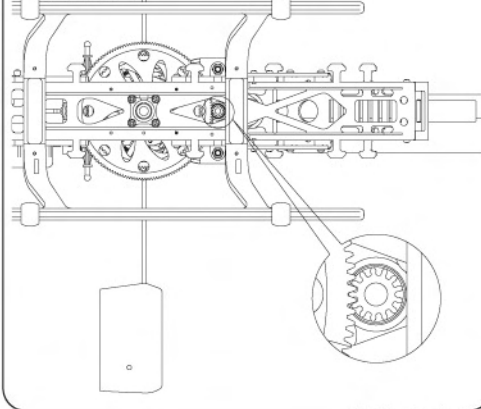

Step 2

1. Attach the motor and the Motor Mount to the Main Frame.
2. Adjust the gear mesh and secure the Motor Mount on the chassis. You can observe the gear mesh from the bottom of Base Plate.

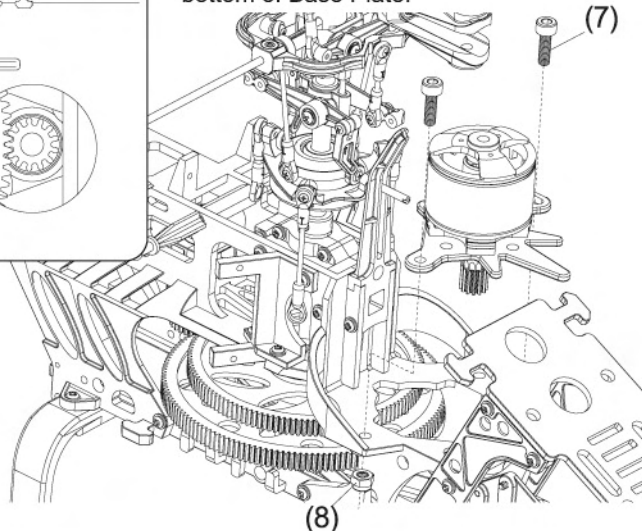

Step 1

- 1.Remove the servo wheel prior to attaching the Linkage Ball.
- 2.Mount the Linkage Ball at 12.5mm from the center of the servo arm.
- 3.Secure the servo to the right Servo Tray and attach the rod to the servo arm.

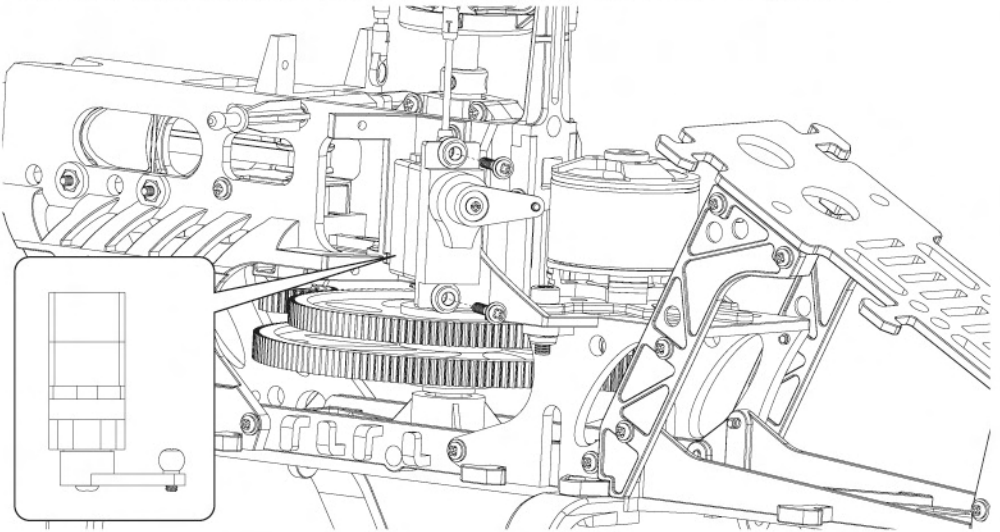

Step 2

- 1.Remove all the servo wheels prior to attaching the Linkage Balls.
- 2.Mount the Linkage Balls at 12.5mm from the center of the servo arms.
- 3.Secure the servos to the left and to the back, attach the rods to the servo arms.

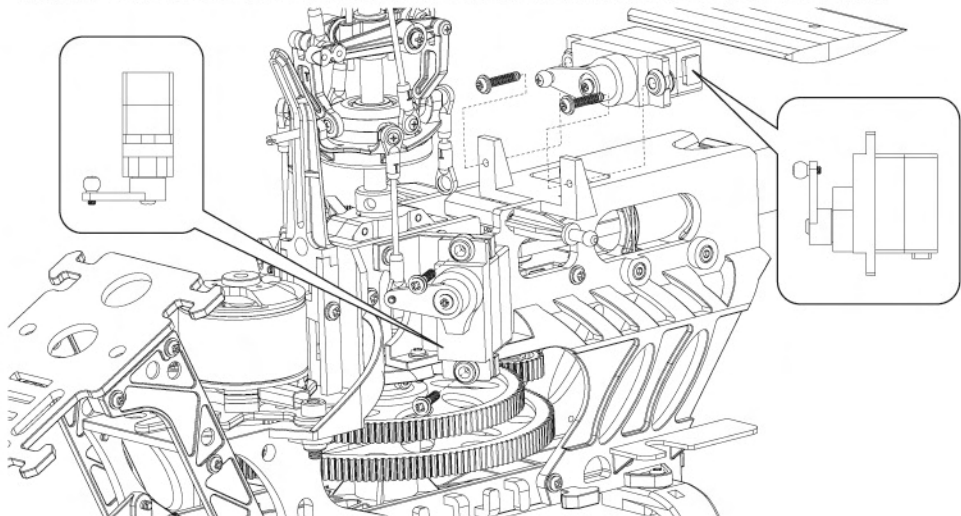

Electric System-3

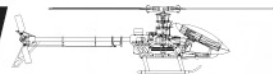

Bag L

No.	Material No.	Description	Qty
1	BK1071	Tail Linkage Rod D1.3	1
2	BK0922	Ball Link 3.8x12mm	2
3	BK1203	Linkage Ball(∅3.8)	4
4	HSP16-6N	Countersunk Screw M1.6x6	4

Step 1

- 1.Remove the tail servo wheel prior to attaching the Linkage Ball.
- 2.For the rudder servo, mount the Linkage Ball at 10.5mm from the center of the servo arm as beginning. Please refer to the manual of your gyro to choose the length of the arm.
- 3.Secure the servo to the Tail Servo Tray and attach the rod to the servo arm.

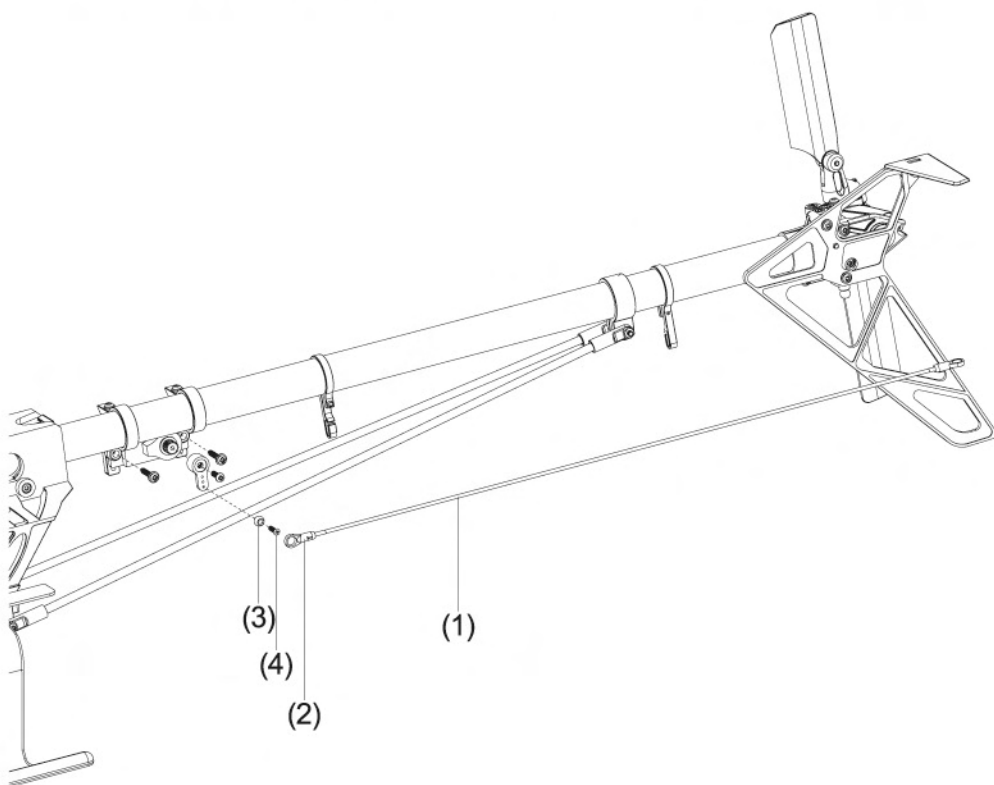

Electric System-4



No.	Material No.	Description	Qty
1	BK1028	Antenna Tube	1
2	BK1088	Rubber Tube 10mm	2

Step 1

1. Attach the receiver, gyro to the Main Frame by Double Side Tap.
2. Insert the Antenna Tube and fix it by the Rubber Tube.

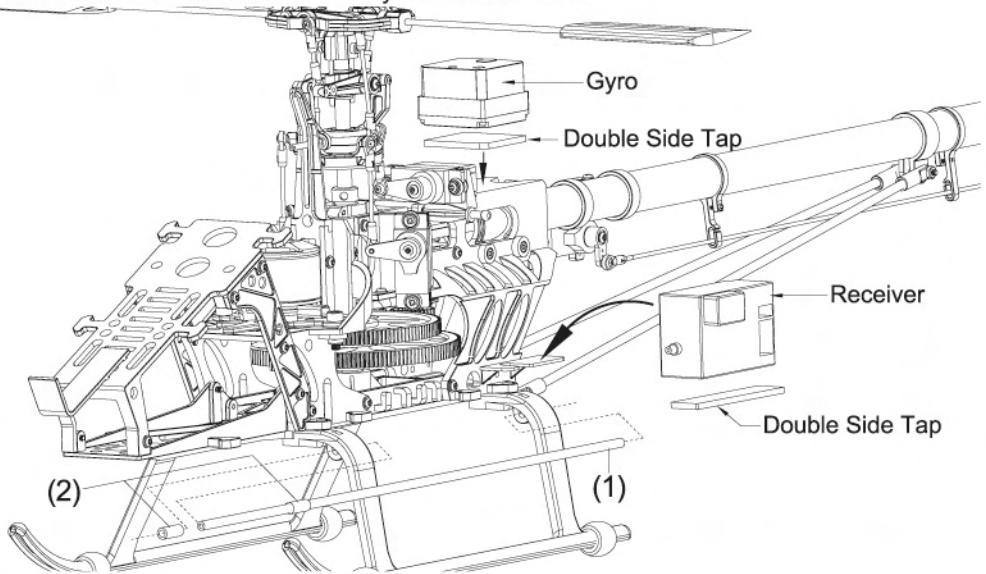

Step 2

Set the battery on the tray by Rubber Band.

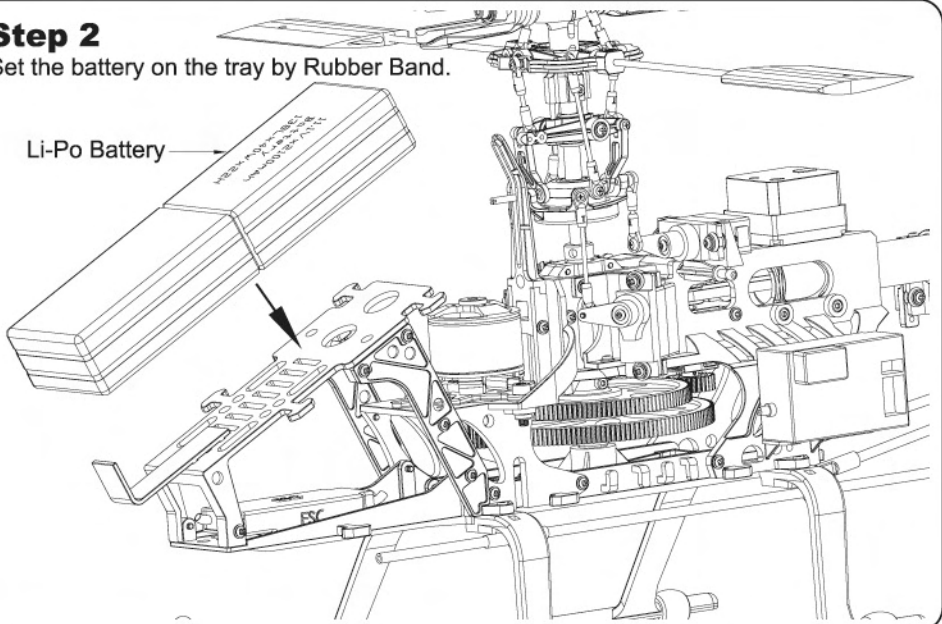

Canopy Assembly



Bag M

No.	Material No.	Description	Qty
1	BK1087	Canopy	1
2	BK1076	Body	1
3	HMJ12-3B	Tapping Screw M1.2x3	3
4	BC1520	Rubber Grommet	2

Step 1

1. Cut off the unnecessary part from the body and the canopy.
2. Attach the canopy to the body by 3 self-tapping screws.
3. Insert the Rubber Grommet to the body as shown.

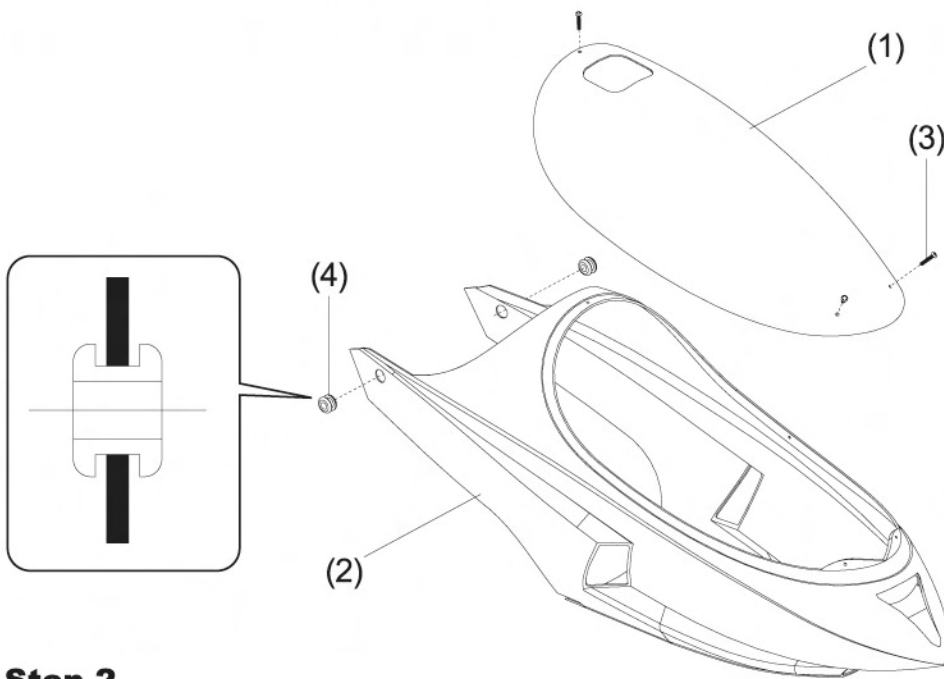

Step 2

Cut the Body as shown.

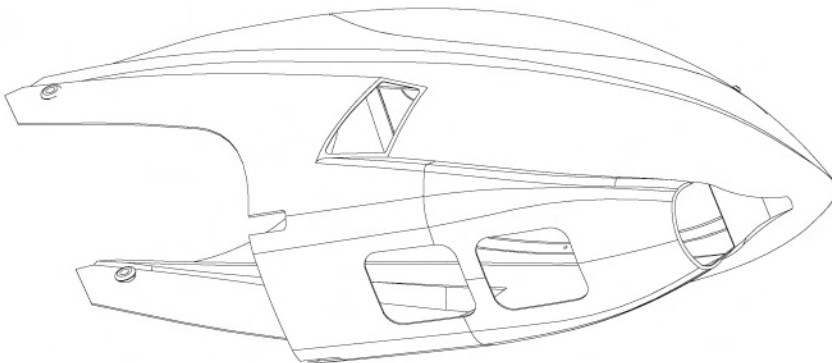

Main Rotor Blade Assembly



No.	Material No.	Description	Qty
1	BK1061	Main Rotor Blade	2
2	BK1067	Upper Blade Grip	2
3	BK1068	Lower Blade Grip	2
4	HSP16-6N	Countersunk Screw M1.6x6	2
5	HMC3-20B	Socket Screw M3x20	2
6	HMM3Z	M3 Nylon nut	2
7	JD0451	Sticker for C.G	1

Note:



Step 1

1. For safety concern, be sure to modify the main blades as following.
2. Mark around the blade grips with a felt tip marker.
3. Remove the blade grips and cut the covering gently around 1mm inside of the mark. Be Careful not to hurt the blades.
4. Sand the inside of the grips lightly for better adhesion. Apply CA or Epoxy to blades in area as shown.
5. Attach blade grips and tighten the screws.
6. Wipe off the excess CA or Epoxy.

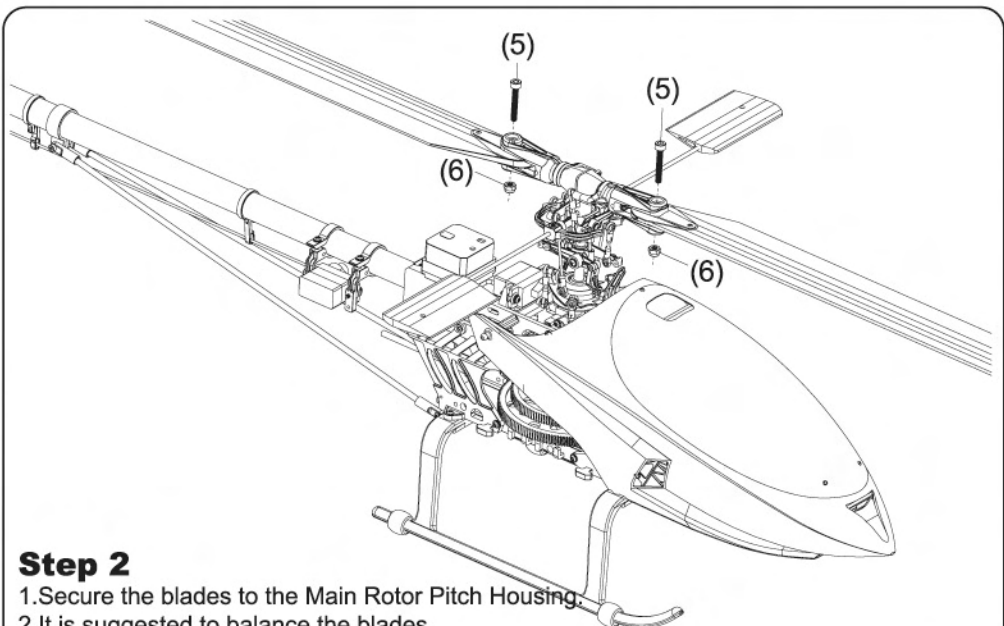
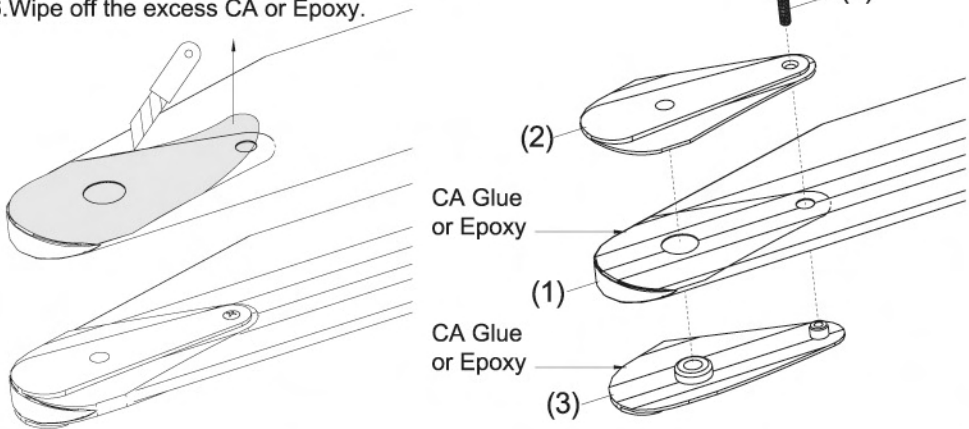

Step 2

1. Secure the blades to the Main Rotor Pitch Housing.
2. It is suggested to balance the blades.

INTRODUCTION OF E-CCPM CONTROL SYSTEM



The E-CCPM(Electric Cyclic/Collective Pitch Mixing) system offers the users a control system that can accomplish the same control as traditional M-CCPM(Mechanical Cyclic/Collective Pitch Mixing) system, but with simple machinery. The 120° E-CCPM system utilizes 3 servos for the main control of aileron, elevator and collective pitch. The 3 servos work independently from each other of M-CCPM system, but they work as a team to achieve the same control of the E-CCPM system. For example, if a collective input is given, all of the 3 servos work together to move the swashplate up and down. If an aileron input is given, 2 servos work at the same time to make the swashplate inclined. With servos working together during any given command, the torque is maximized. In addition, E-CCPM system execute the given control inputs with less complex mechanical mixing systems and require less control rods and parts.

In today's modern computer radio system, the E-CCPM system is established in the program. Since the 120° E-CCPM function are preprogrammed, there is no more complicated mixing/setup than the M-CCPM system. For the radio type and brand, please choose which has the 120° E-CCPM function. Please note that it is not possible to use a non-E-CCPM radio system for E-CCPM operation without any other electronic mixer.

MOVEMENT OF 120° ECCPM SYSTEM



The given inputs are executed by the team work of the 3 servos through the mixing program of the radio or the electronic mixer. The following are the examples showing how the movement be carried out.

COLLECTIVE PITCH

When a collective pitch command is given, all of the 3 servos move toward the same direction with same speed and same travel distance. This movement is to raise or lower the swashplate and keep the swashplate level. Thus, the required collective pitch can be reached without cyclic input.

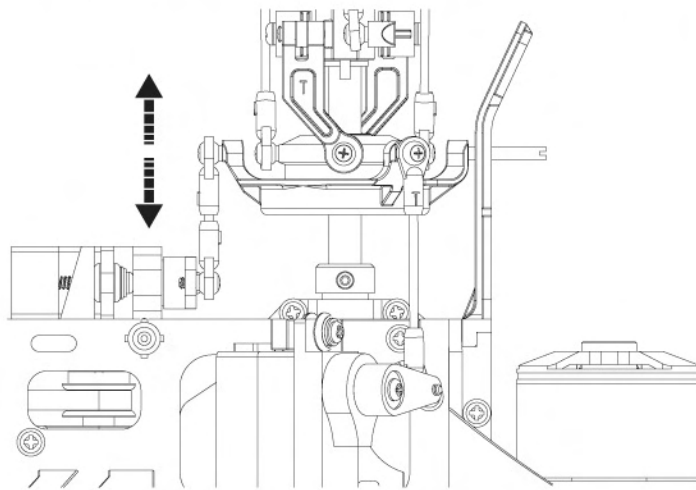

AILERON

Aileron is controlled by the 2 servos in the front. When an aileron command is given, one servo will pull the swashplate downward and the other will push the swashplate upward so that the roll command is executed. They move contrary with same speed and travel distance, and the third servo in the back remains still at this moment.

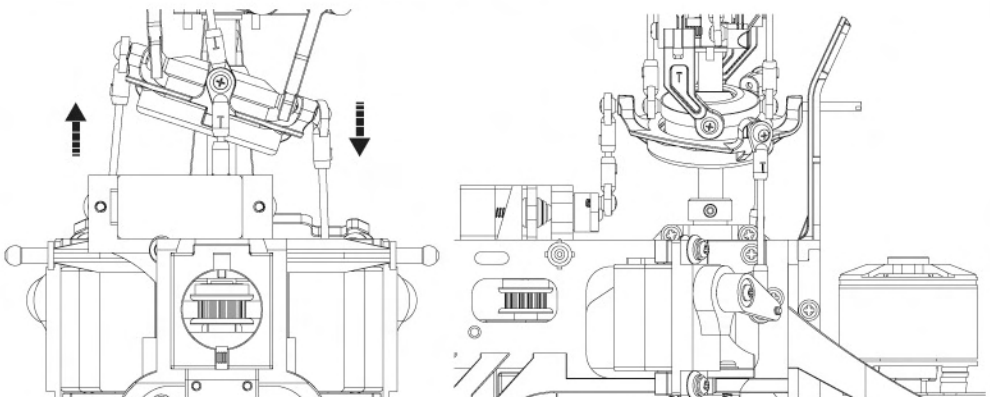

MOVEMENT OF 120° ECCPM SYSTEM



ELEVATOR

The elevator is controlled by all of the 3 servos. When an elevator command is given, the 2 servos in the front move in the same direction and the third one move contrary. For example, when a down elevator command is given, the 2 front servos pull the swashplate downward and the third one push the swashplate upward so that the down elevator command is executed. The 3 servos pull/push the swashplate at the same time to accomplish the given command.

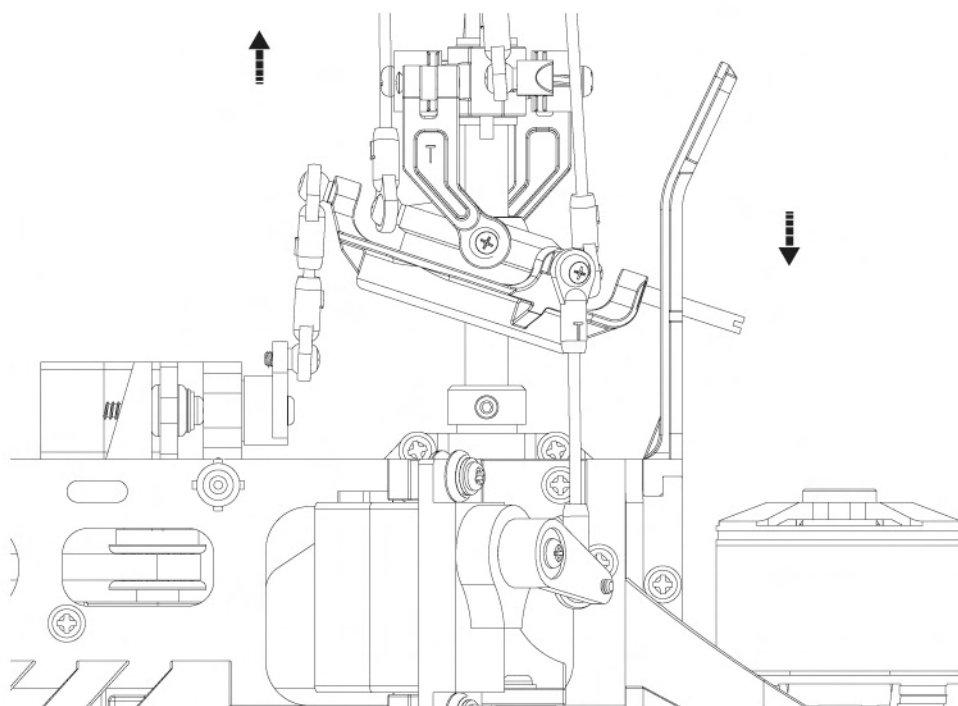

SERVO CONNECTING



E-CCPM system requires 3 channel for aileron, elevator and an AUX(for pitch). But people may get confused because the 3 channels are not referred to any independent movement. They are operated together to carry out the rolling, flipping and collective controlling. As a result, the following connecting manner is recommended.

1. The rear servo located in back of the swashplate **MUST** be plugged into the elevator channel.
2. Suppose the servo in the right side is plugged into the aileron channel.
3. The left servo is plugged into the AUX channel.

The following chart is the E-CCPM connecting for your reference. Please also consult your radio instruction manual.

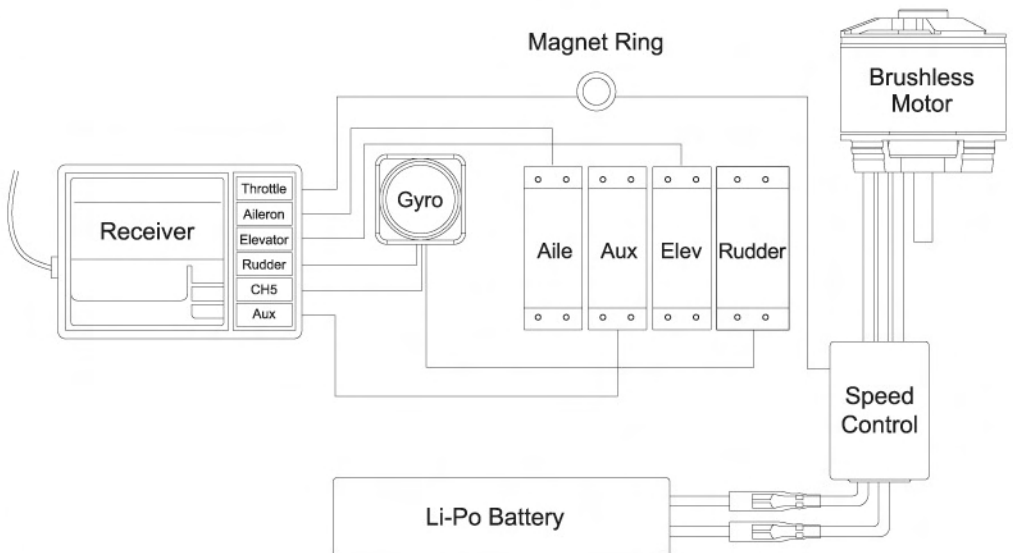

BASIC CONCEPT OF ADJUSTMENT



Because people may be confused with the operating manner of the E-CCPM system, we want to explain the basic concept of how to center and trim the servo while adjusting the full travel distance.

First of all, we have to make it clear about what do you want to adjust. Do you want to adjust the servo itself or the control surface? For example, if you want to adjust the servo which is plugged into the aileron channel itself, only the servo will be adjusted. But if you want to adjust the aileron "rolling" surface, the two servos plugged into aileron and AUX channels will be adjusted. Making clear of this basic concept will simplify the process of adjustment.

Furthermore, you have to realize the function of "Reverse", "Sub Trim", "Trim", "Travel Adjustment", "D/R & EXP" and "Swash Mixing" of the transmitter. There are different names for those functions between different brands of the radio, but their definitions are basically the same. The following table shows the functions which those items refer to:

Items		Adjust the Servo Itself	Adjust the Control Movement
Reverse		<input type="radio"/>	
Sub Trim		<input type="radio"/>	
Travel Adjustment		<input type="radio"/>	
Trim			<input type="radio"/>
D/R & EXP			<input type="radio"/>
Swash Mixing	± Aileron		<input type="radio"/>
	± Elevator		<input type="radio"/>
	± Pitch		<input type="radio"/>

Therefore, if you want to adjust servos themselves, please use the "Reverse". "Sub Trim", and "Travel Adjustment". If you want to adjust the control surface, please use the "Trim", "D/R & EXP" and "Swash Mixing".

For example, it is necessary to do minor centering adjustments to achieve the desired servo arm position with the "Sub Trim" function. Under this circumstance, you have to adjust the servo itself, not the control surface.

Before starting, make sure the following preparation is done.

1. Set all trims, knobs, and switches to the neutral and zero position.
2. Reset the radio to its factory preset position.
3. Choose the 120° E-CCPM swashplate control mode.

Reversing/Swash Mixing

The moving direction of servos has to be confirmed. You can attach the servo arms to the servos temporarily so that it makes it easier to see the servos moving direction. While giving a positive collective pitch, all of the 3 servos are supposed to be moving in the same direction to descend the swashplate. If the 3 servos are moving in the same direction but to raise the swashplate, you have to use the “swash mixing” function to make it descend. If any of the servos is moving contrary, you have to adjust the one by “reverse” function. Since the moving manner above is determined, the “reverse” function of Aile/Elev/AUX is done.

Next, you have to check the control surface. While giving a cyclic pitch control, the swashplate has to be tilted toward the correct direction. If not, you have to adjust it by “swash mixing” function. For example, if a down elevator command is given, the swashplate is supposed to be tilted forward. If the swashplate is tilted rearward, you have to change the +/- of the elevator control surface by “swash mixing” function. So as the aileron control surface.

To sum up, the “reverse” function is to adjust the servo itself, and the +/- of the “swash mixing” function is to adjust the control surface.

Servo Arms

After the moving direction of the servos is determined, please center the collective control stick. With the collective control stick is centered, install the servo arms of the 3 servos. They are supposed to be level. If the servo arms tilt with a small degree, use the “sub trim” function to adjust it independently. Thus the procedure of centering is complete.

CONCEPT OF BASIC SETTING AND ADJUSTMENT



Level the Swashplate

After centering the servos, setting the length of the control linkages and attaching them to the link balls, it is important to check the swashplate that it is level. Turn on the transmitter and the receiver, do not plug in the ESC at this moment, and center the collective pitch stick. Make sure all the trims and knobs are centered and the pitch curve should be 0% at low end and 100% at high end at present. The servo arms should be level. While the collective pitch stick is centered and the servo arms are level, the swashplate is supposed to be level. First, check the swashplate from the rear of the model to insure if it's level from left to right. If the swashplate is not level as compared to the frame of the model, adjust either the left or right servo control rods. Next, check the swashplate from a side of the model to insure if it's level from head to rear. If the swashplate is not level, adjust the control rod of the servo in the back.

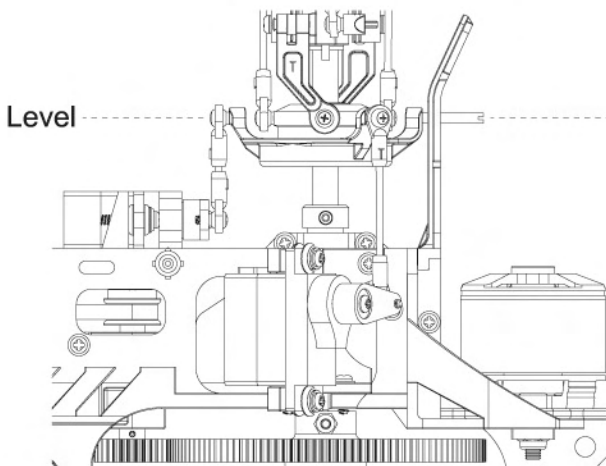
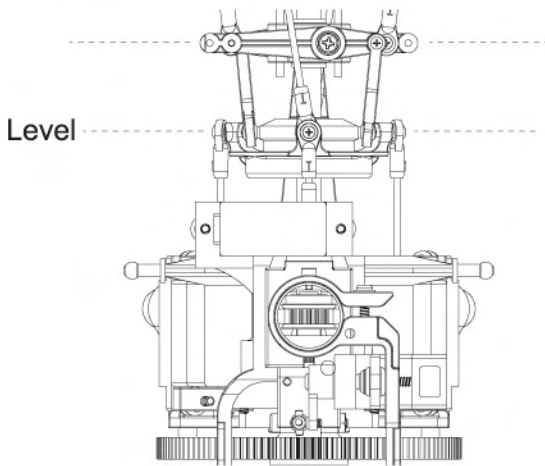

COLLECTIVE TO CYCLIC MIXING ADJUSTMENT



It always happens that the travel of each servo varies slightly. If so, the swashplate would be tilted when giving a full collective pitch command. These variations can be corrected by altering the travel value of each servo slightly by using the “Travel Adjustment” function.

Pitch to Aileron Mixing

Place the collective stick to the full positive pitch position. Check the swashplate from the rear of the model to insure if it's level from left to right. If the swashplate is not level as compared to the frame of the model, adjust either the servos by using the “Travel Adjustment” function.

For example, the swashplate has been tilted to the right side while giving full positive collective pitch. It indicates that the left servo's travel is less than the right servo's travel. You can either increase the travel of left servo or decrease the travel of right servo. Check the swashplate again to insure that it's level.

It is necessary to repeat the procedure while giving full negative collective pitch. Check if the swashplate is level and adjust the servos as needed while the full negative collective pitch is given.

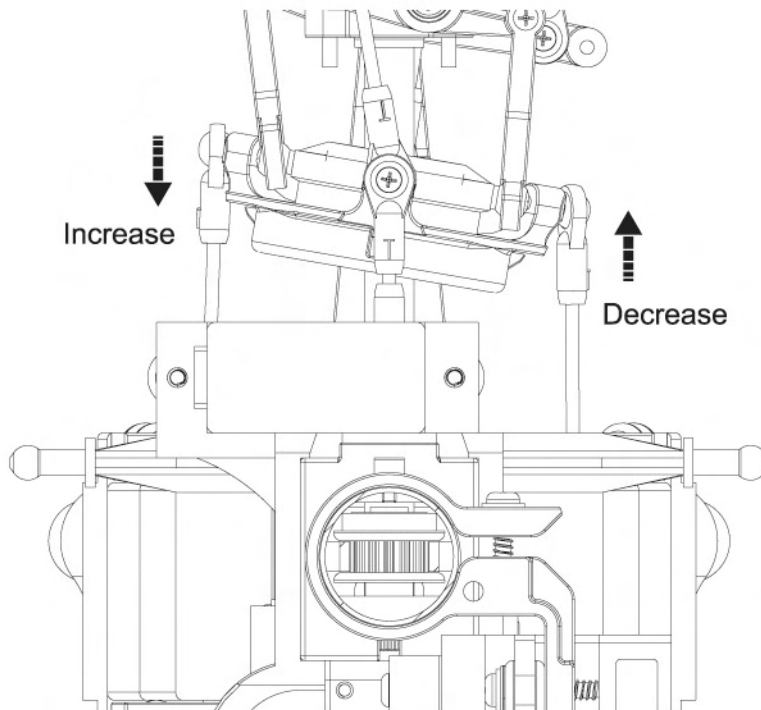

COLLECTIVE TO CYCLIC MIXING ADJUSTMENT



Pitch to Elevator Mixing

Through the previous step, we've got rid of the pitch to aileron mixing. It is as important to vanish the pitch to elevator mixing. Place the collective stick to the full positive pitch position. Check the swashplate from a side of the model to insure if it's level from head to rear. If the swashplate is not level, adjust the elevator servo by using the "Travel Adjustment" function.

For example, the swashplate has been tilted forward while giving full positive collective pitch. It indicates that the elevator servo's travel is less than the rest two's travel. Please increase the travel of elevator servo. Check the swashplate again to insure that it's level.

It is necessary to repeat the procedure while giving full negative collective pitch. Check if the swashplate is level and adjust the elevator servo as needed while the full negative collective pitch is given.

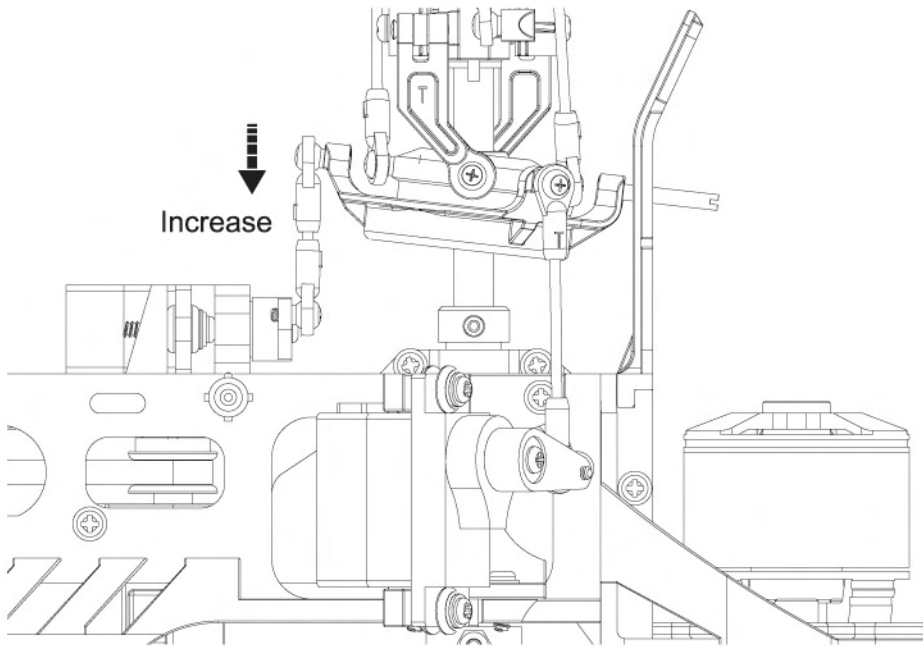

SETTING UP OF LINKAGE



The lengths of the linkage rods are recommended as the following:

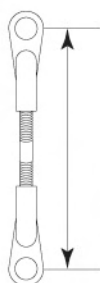
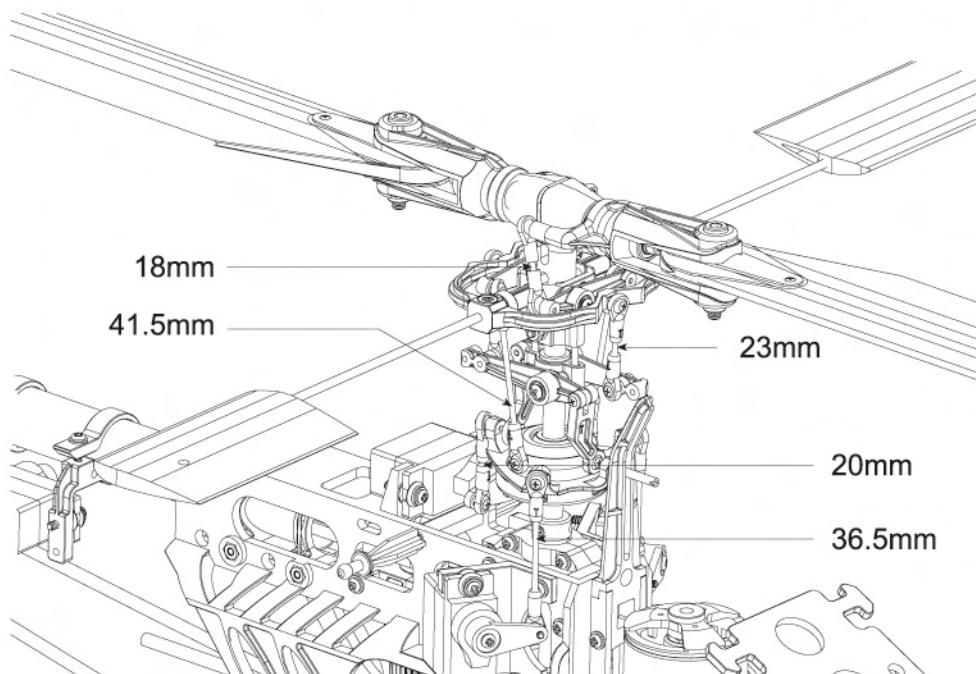

Lengths are measured from ball link center to ball link center.

The pushrod length above is suitable for beginner and 3D flying. You can use those lengths as the starting setting, and adjust the lengths for your flying style. The lengths of the pushrods are measured from the center of the linkage ball to the center of another.

SETTING UP MAIN ROTOR COLLECTIVE PITCH ANGLE

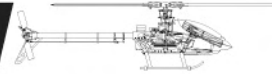

Since you have been setting the lengths of the pushrod as mentioned, the linkage should be centered well as described below.

Centering

1. The levers should be as the drawing below while centering the collective pitch stick.
2. Parallel the flybar, the main blades should be at 0 degree and the swashplate should be level.

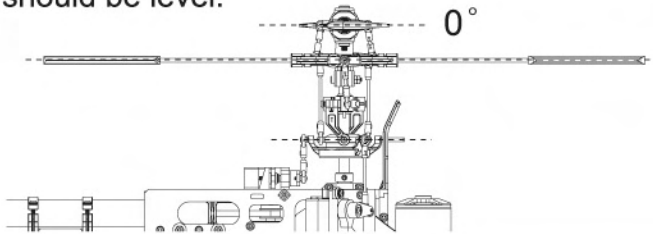

Maximizing

1. Place the collective stick at high end.
2. The main blades should be at 10 degree and the swashplate should be level.

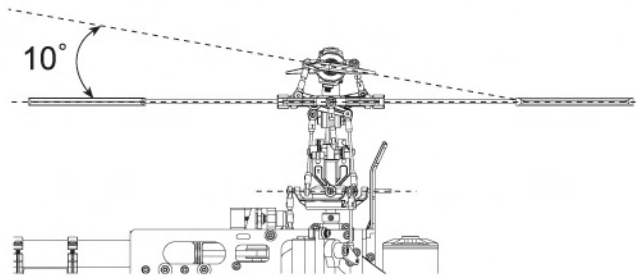

Minimizing

1. Place the collective stick at low end.
2. The main blades should be at 10 degree and the swashplate should be level.

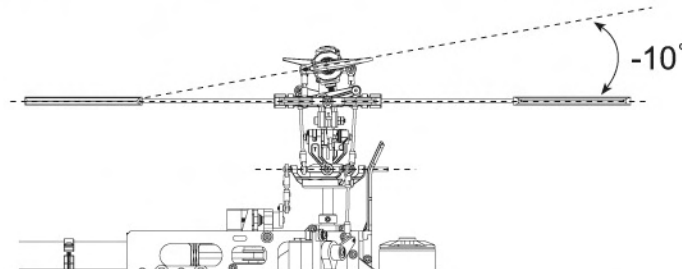

NOTE:

1. The steps above define the limits of the collective pitch setting.
2. The setting of the maximum collective pitch depends on your personal flying skill and style. Too much collective pitch could overload the ESC, motor and the battery. And it will reduce the flying time also.

SETTING UP DATA FOR YOUR REFERENCE



The following is the setting up data of pitch curve and throttle curve for your reference only. Please ask experienced pilot to help you if you have never done this before.

Beginner

Throttle Curve

	1	2	3	4	5
Normal	0	45	65	85	100

Pitch Curve

	1	2	3	4	5
Normal	40	-	75	-	100

Pitch Angle

	1	2	3	4	5
Normal	-2°	-	+5°	-	+10°

Throttle Curve

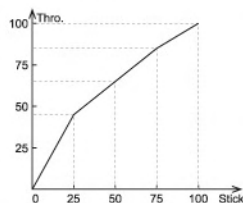

Pitch Curve

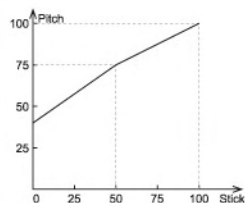

Aerobatic Flying

Throttle Curve

	1	2	3	4	5
Normal	0	45	65	85	100
Idle 1	80	-	70	-	100
Idle 2	100	-	80	-	100

Pitch Curve

	1	2	3	4	5
Normal	30	-	75	-	100
Idle 1	20	-	75	-	95
Idle 2	5	-	-	-	95
Hold	0	-	-	-	100

Pitch Angle

	1	2	3	4	5
Normal	-4°	-	+5°	-	+10°
Idle 1	-6°	-	+5°	-	+9°
Idle 2	-9°	-	-	-	+9°
Hold	-10°	-	-	-	+10°

Throttle Curve

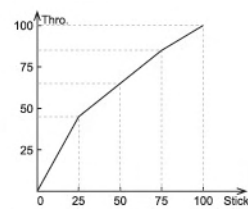

⊙ Normal

Pitch Curve

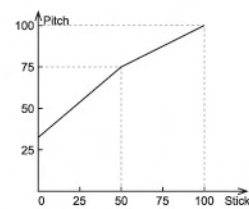

⊙ Normal

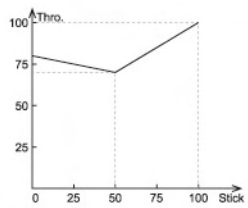

⊙ Idle-up 1

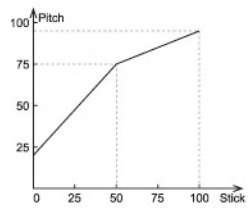

⊙ Idle-up 1

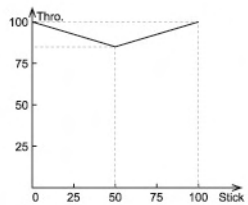

⊙ Idle-up 2

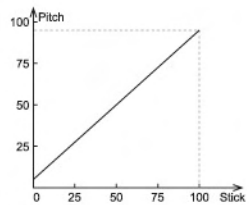

⊙ Idle-up 2

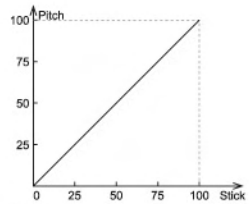

⊙ Hold

TAIL CONTROL AND GYRO SETUP

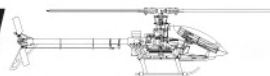

It is recommended to use a Heading Hold Gyro. With a Heading Hold Gyro, you may not use the trim and the revolution mixing function of tail control.

First, choose the length of the tail servo arm referring to the manual of the Gyro. You may try 10.5mm as the starting setting. Then mount the servo arm for the moment and check the movement of the tail servo:

1. While giving the right rudder control, the servo arm should move forward.
2. Rotate the helicopter with your hand counterclockwise, the servo arm should move forward.

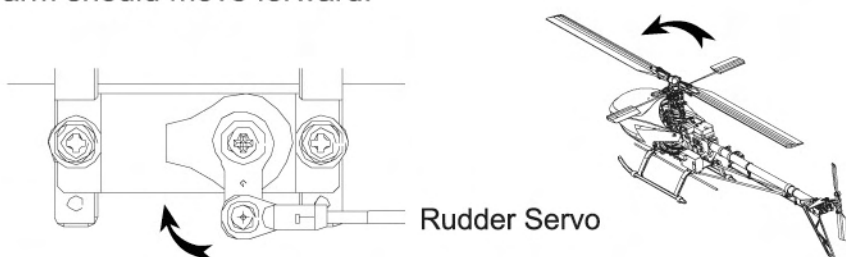

After making sure of moving direction of tail servo, you have to mount the servo arm in the correct position. Please reset the receiver power and do not move the helicopter. While the tail control stick and trim are centered, mount the servo arm vertically. If you cannot mount the servo arm vertically, please use the "sub trim" function to position the arm. Restart the power of receiver after using "sub trim" function so that the Gyro can reset the neutral point. Next, two points may be your concern:

1. The traveling limit of the tail servo may not go beyond the mechanical movement.
2. The tail servo horn should be vertical while the tail rotor are at 0 pitch or with a little offset to the right.(Referring to the photo below)

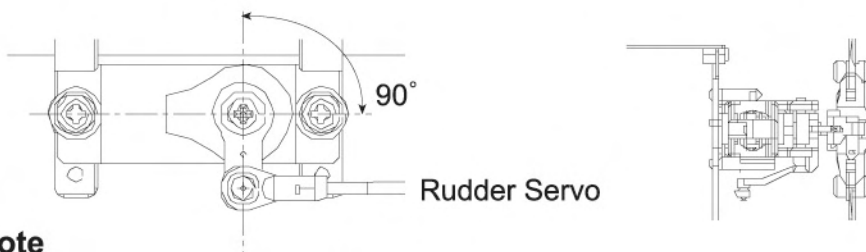

Note

1. To find the traveling limit, you have to adjust the Gyro referring to its manual.
2. To adjust the pirouetting speed of the helicopter, please use the "Travel Adjustment" or the "D/R & EXP" function.

USING OF LI-PO BATTERY



The mini Titan E325 is an electric RC helicopter. It is strongly recommended to use Lithium Polymer Battery. Please refer to the following information and precaution:

1. Do use a charger that is designed for Li-Poly batteries only.
2. Do not overcharge the battery over the maximum voltage of 4.2V/per cell.
3. Do not discharge the battery below the minimum voltage of 3.0V/per cell.
4. Do not charge the battery unattended.
5. Do not charge the battery in a flammable circumstance.
6. If you want to store the battery for a long time, store them at 3.8V/per cell.

Please understand the information and precaution above and that you agree to accept the full responsibility of using the battery and any injury caused by the battery. Thunder Tiger and its duly authorized distributors assume no liability for damage that could occur by the improper using of the battery.

TROUBLE SHOOTING

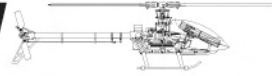

Helicopters

Q: What would you check when the helicopter shakes during flying?

- A:**
- Are the main blades out of track?
 - Are the paddles out of track?
 - Are the main blades well balanced?
 - Are the paddles well mounted at the same distance from the rotor shaft?
 - Is the spindle or the flybar bent?
 - Is the main shaft bent?
 - Is the main rotor hub damaged?
 - Is the motor well installed and is the shaft of the motor bent?
 - Is the tail rotor shaft bent?
 - Is the tail rotor hub damaged?
 - Do all the ball bearings work well?

Q: What would you do if there comes out a lot of noise from the helicopter during flying?

- A:**
- Please check the gear mesh between the main gear and the motor pinion. If there is too much gear mesh, it would generate a lot of gear noise during flying.
 - If the tail drive belt is too loose, it will bring about some noise and may cause the failure of tail control.
 - Check the linkages and control system of main rotor and tail rotor to make sure every linkage is working correctly and not colliding with something else.
 - Check if the motor is running out of balance.

Motor, Battery and Speed Controller

Q: How to choose the motor and the pinion?

A: It depends on the battery and the motor. The following is the formula of how to calculate the wanted head speed.

$$\text{Motor RPM} = \text{Motor KV} \times \text{Volt}(3.7\text{V}) \times \text{Series} \times \text{constant} (0.8)$$

$$\text{Head Speed} = \text{Motor RPM} / \text{Gear Ratio}$$

$$\text{Gear Ratio} = 150\text{T} / \text{Motor Pinion}$$

Example:

We choose TT OBL 29/35-10H brushless motor.

IF using a 3S(11.1V) Li-Po battery, the motor rpm should be
 $3500\text{KV} \times 3.7\text{V} \times 3\text{S} \times 0.8 = 31080 \text{ rpm}$

And we expect to have the head speed of 2600~2800rpm

$$31968 / \text{Gear Ratio} = 2800$$

$$\text{Gear Ratio} = 11.1$$

TROUBLE SHOOTING



The pinion would be

$$150T / 11.1 = 13.51$$

So we choose 13T as the motor pinion.

IF using a 2S(7.4V) Li-Po battery for long time hovering, the motor rpm should be

$$3500KV \times 3.7V \times 2S \times 0.8 = 20720 \text{ rpm}$$

And we expect to have the hovering head speed of 2100rpm

$$20720 / \text{Gear Ratio} = 2100$$

$$\text{Gear Ratio} = 9.87$$

The pinion would be

$$150T / 9.87 = 15.20$$

So we choose 15T as the motor pinion.

Q: Which motor and speed controller is recommended?

A: The TT OBL 29/35-10H brushless motor(No.2381) and the ACE BLC-40(No.8041-H) speed controller are recommended.

E325 SPARE PARTS



PV0701
MAIN ROTOR HUB



PV0702
FLYBAR SEESAW HUB

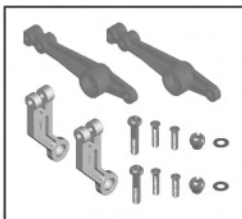

PV0703
FLYBAR CONTROL ARM

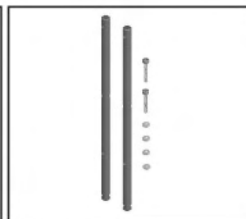

PV0704
MAIN SHAFT(2)



PV0705
MAIN ROTOR GRIP

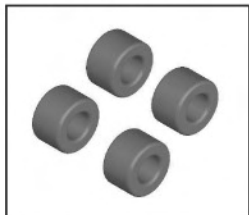

PV0706
FLAP DAMPER(70°)



PV0707
FEATHERING SHAFT(2)



PV0708
FLYBAR CONTROL ARM



PV0709
FLYBAR(2)



PV0710
SWASHPLATE



PV0711
WASHOUT BASE SET



PV0712
MIXING LEVER



PV0713
WASHOUT BASE

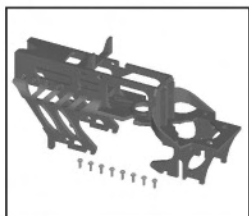

PV0714
MAIN FRAME

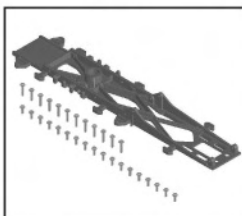

PV0715
BASE PLATE

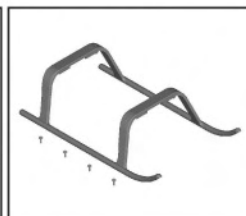

PV0716
LANDING SKID



PV0717
UPPER BRG HOUSIN

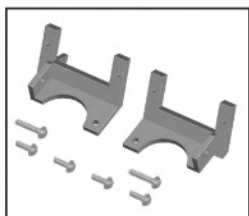

PV0718
SERVO TRAY



PV0719
BATTERY TRAY



PV0720
BODY RETAINING POST(2)



PV0721
PHASE CONTROL TRACK



PV0722
AUTO-R TAIL DRIVE GEAR



PV0723
MAIN GEAR (W/BEARING)

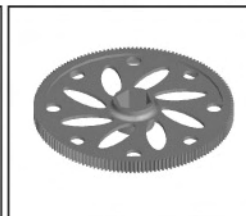

PV0724
MAIN GEAR ONLY 50T

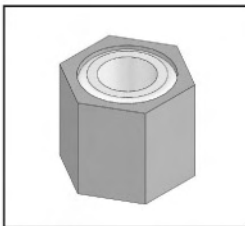

PV0725
M.G. HEX DRIVE HUB



PV0726
ONE WAY SHAFT



PV0727
M. SHAFT LOCK RING(2)



PV0728
MOTOR MOUNT

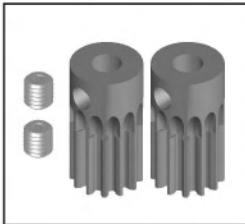

PV0729
PINION 13T(2)



PV0730
PINION 10T(2)

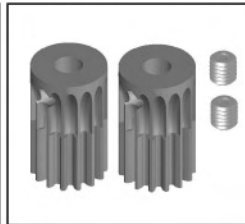

PV0731
PINION 15T(2)

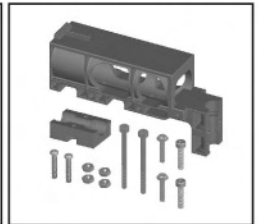

PV0732
TAIL BOOM BRACKET

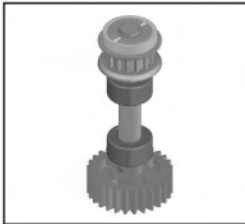

PV0733
TAIL DRIVE GEAR SET

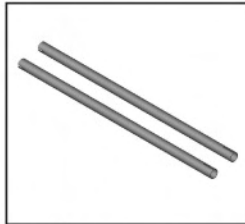

PV0734
TAIL BOOM(2)

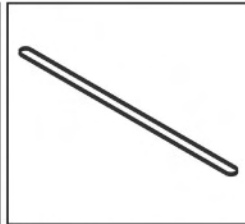

PV0735
TAIL DRIVE BELT, MXL413T

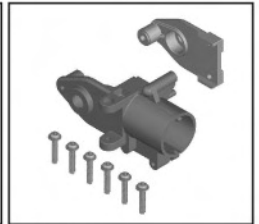

PV0736
TAIL UNIT CASE SET



PV0737
TAIL ROTOR SHAFT



PV0738
TAIL PITCH CONTROL SET



PV0739
TAIL PITCH CONTROL LINK(4)



PV0740
TAIL ROTOR GRIP



PV0741
TAIL ROTOR HUB



PV0742
TAIL ROTOR

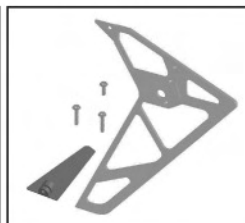

PV0743
TAIL FIN SET



PV0744
FLYBAR PADDLE



PV0745
MAIN ROTOR BLADE, 315mm

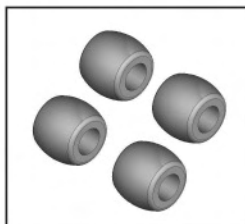

PV0746
SKID DAMPER



PV0747
TAIL SERVO TRAY



PV0748
DOUBLE JOINT LEVER

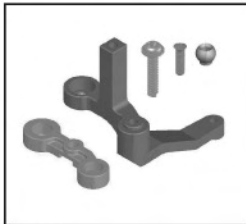

PV0749
TAIL P. CONTROL LEVER



PV0750
TAIL P. CONTROL SLIDER

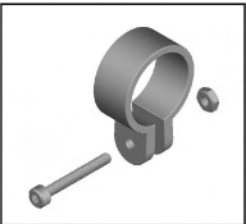

PV0751
TAIL SUPPORT BRACKET

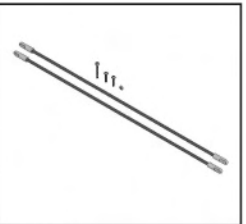

PV0752
TAIL SUPPORT

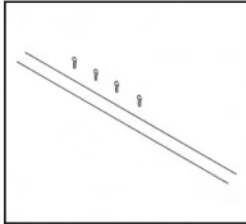

PV0753
TAIL LINKAGE ROD

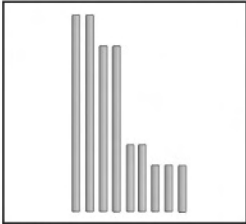

PV0754
LINKAGE ROD SET

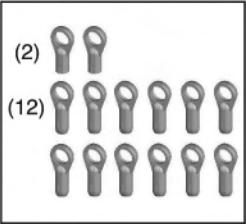

PV0755
BALL LINK, Ø3.8

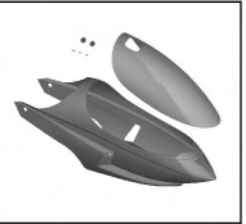

PV0756
BODY SET

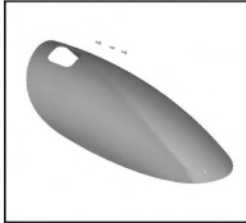

PV0757
CANOPY



PV0758
BODY ONLY



PV0759
BLADE HOLDER



PV0760
ANAEROBICS RETAINER, R48



PV0761
THREADLOCKING, T22



PV0762
TAIL ROD GUIDE

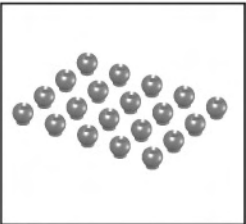

PV0763
LINKAGE BALL Ø3.8(20)

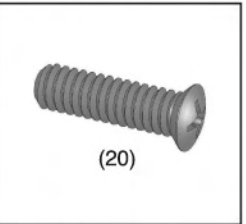

PV0764
COUNTER SCREW, M1.6x6(20)

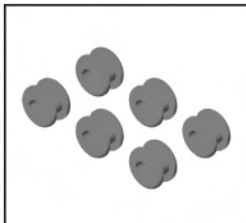

PV0765
BODY MOUNT RUBBER



PV0766
DECAL

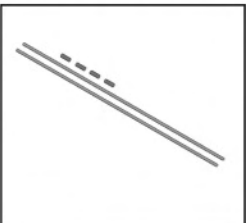

PV0767
ANTENNA TUBE SET

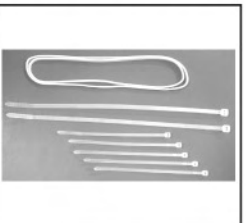

PV0768
RUBBER BAND AND NYLON STRAP SET



PV0769
THRUST BEARING(2), d4xD9x4

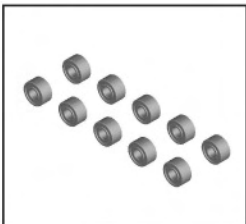

PV0770
BEARING(10), d2xD5x2.5t



PV0771
BEARING(4), d4xD9x4t

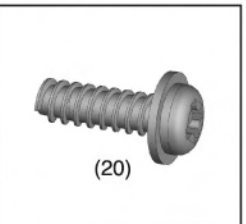

PV0772
TAPPING SCREW (WASHER), M2x6

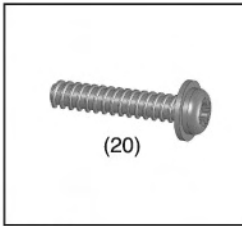

(20)

PV0773
TAPPING SCREW (W/WASHER), M2x10

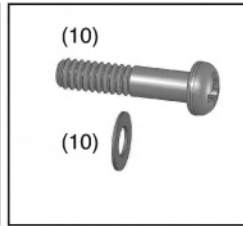

(10)

(10)

PV0774
SHOULDERED SCREW, M2x9

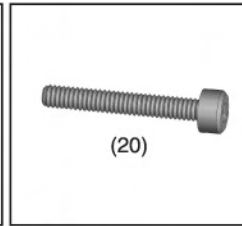

(20)

PV0775
SOCKET SCREW(20), M2x14

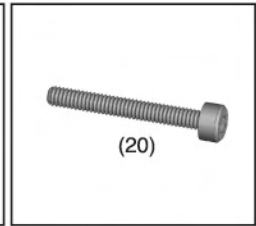

(20)

PV0776
SOCKET SCREW(20), M2x16

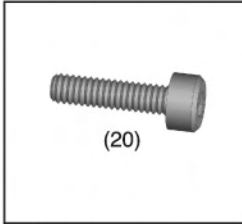

(20)

PV0777
SOCKET SCREW(20), M2x8

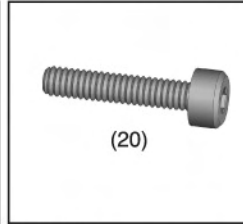

(20)

PV0778
SOCKET SCREW(20), M2x10

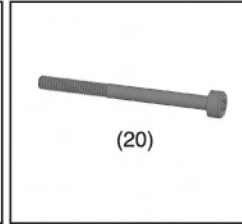

(20)

PV0779
SOCKET SCREW(20), M2x25

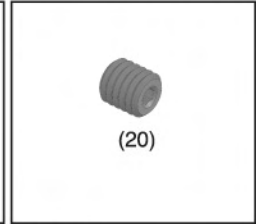

(20)

PV0780
SET SCREW(20), M3x3

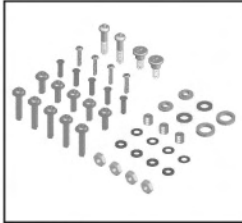

PV0781
SCREW BAG

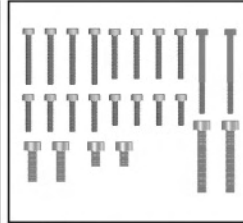

PV0782
SOCKET SCREW BAG

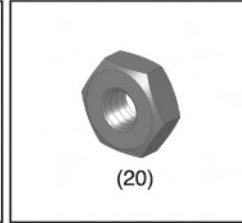

(20)

PV0234
NUT(20), M2

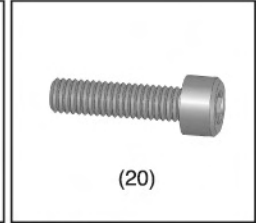

(20)

PV0211
SOCKET SCREW(20), M2.6x20

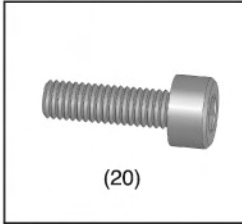

(20)

PV0212
SOCKET SCREW(20), M3x10

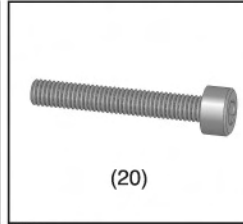

(20)

PV0257
SOCKET SCREW(20), M3x20

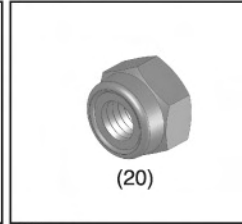

(20)

PV0236
LOCK NUT(20), M3

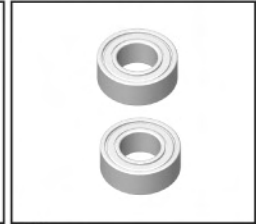

PV0048
BALL BEARING, d4xD8xW3

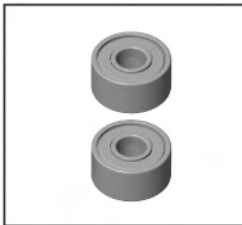

PV0049
BALL BEARING, d3xD8xW4

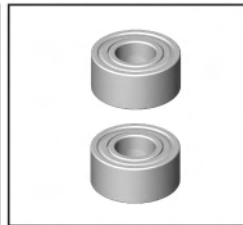

PV0059
BALL BEARING, d5xD11xW5

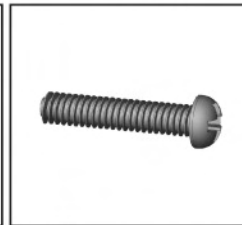

PV0229
BT P.TAP SCREW, M2x10

No.	NAME	Parts No.	Quantity
PV0701	MAIN ROTOR HUB	BV1083	1
PV0702	SEESAW HUB	BK1045	1
	FLAT WASHER, d2xD3.8x0.2t	BK0920	2
	SHOULDERED SCREW, M2x9	HNU2-9Z	2
	SHOULDERED SCREW, M2x6	HNV2-6Z	2
PV0703	FLYBAR CONTROL LEVER	BK1058	2
	WASHOUT LINKAGE	BK1014	2
	LINKAGE BALL(Ø3.8)	BK1203	2
	SHOULDERED SCREW, M2x9	HNU2-9Z	2
	FLAT WASHER, d2xD3.8x0.2t	BK0920	2
	COUNTERSUNK SCREW, M1.7x7	HSP17-7N	2
	COUNTERSUNK SCREW, M1.6x6	HSP16-6N	2
PV0704	MAIN SHAFT	BK1051	2
	SOCKET SCREW, M2x14	HMC2-14B	2
	HEX NUT, M2	HML2	4
PV0705	MAIN GRIP	BK1050	2
	COUNTERSUNK SCREW, M1.6x6	HSP16-6N	2
	LINKAGE BALL(Ø3.8)	BK1203	2
	DAMPER COLLAR	BK1079	4
	FLAT WASHER, d2.8xD5x0.5t	HMO26	2
	SOCKET SCREW, M2.6x10	HMC2610B	2
PV0706	FLAP DAMPER (700)	BK1054	4
PV0707	FEATHERING SHAFT	BK0906	2
PV0708	FLYBAR CONTROL ARM	BK1015	1
	COLLAR, d3xD4.5x7	BK1044	2
	LINKAGE BALL(Ø3.8)	BK1203	2
	COUNTERSUNK SCREW, M1.6x6	HSP16-6N	2
	SET SCREW, M3x3	HME3-3B	2
PV0709	FLYBAR	BK0916	2
PV0710	SWASHPLATE	BV1010A	1
PV0711	FLYBAR CONTROL LEVER	BK1058	2
	WASHOUT LINKAGE	BK1014	2
	WASHOUT BASE	BK0914	1
	LINKAGE BALL(Ø3.8)	BK1203	2
	FLAT WASHER, d2xD3.8x0.2t	BK0920	2
	SHOULDERED SCREW, M2x9	HNU2-9Z	2
	COUNTERSUNK SCREW, M1.6x6	HSP16-6N	2
	COUNTERSUNK SCREW, M1.7x7	HSP17-7N	2
	BEARING, d2xD5x2.5t	HMV520ZZW	4
PV0712	MIXING LEVER	BK1046	2
	LINKAGE BALL(Ø3.8)	BK1203	4
	COUNTERSUNK SCREW, M1.6x6	HSP16-6N	4
	SHOULDERED SCREW, M2x6	HNV2-6Z	2
	SHOULDERED SCREW, M2x9	HNU2-9Z	2
	FLAT WASHER, d2xD3.8x0.2t	BK0920	2
PV0713	WASHOUT BASE	BK0914	1
	SHOULDERED SCREW, M2x9	HNU2-9Z	2
	FLAT WASHER, d2xD3.8x0.2t	BK0920	2
PV0714	MAIN FRAME	BK1030	1
	TAPPING SCREW (W/WASHER), M2x6	HNN2-6B	8
PV0715	BASE PLATE	BK1018	1
	TAPPING SCREW (W/WASHER), M2x10	HNN2-10B	12
	TAPPING SCREW (W/WASHER), M2x6	HNN2-6B	18
PV0716	LANDING SKID	BK1059	1
	TAPPING SCREW (W/WASHER), M2x6	HNN2-6B	4
PV0717	UPPER BRG HOUSING(LEFT)	BK1034	1
	UPPER BRG HOUSING(RIGHT)	BK1033	1
	TAPPING SCREW (W/WASHER), M2x10	HNN2-10B	8

No.	NAME	Parts No.	Quantity
PV0718	SERVO TRAY(RIGHT)	BK1048	1
	SERVO TRAY(LEFT)	BK1049	1
	TAPPING SCREW (W/WASHER), M2x6	HNN2-6B	4
	TAPPING SCREW (W/WASHER), M2x10	HNN2-10B	2
PV0719	BATTERY SIDE FRAME	BK1022	2
	BATTERY TRAY	BK1021	1
	BATTERY HOLDER	BK1023	1
	TAPPING SCREW (W/WASHER), M2x6	HNN2-6B	8
	TAPPING SCREW (W/WASHER), M2x10	HNN2-10B	2
PV0720	FRAME SPACER	BK1056	2
	CANOPY RETAINING POST	BK1057	4
PV0721	PHASING CONTROL TRACK	BK1037	1
	TAPPING SCREW (W/WASHER), M2x6	HNN2-6B	2
PV0722	AUTO-R TAIL DRIVE GEAR	BK0933	2
PV0723	MAIN GEAR (W/BEARING)	BV0934	1
PV0724	MAIN GEAR 150T	BK0934	2
PV0725	HEX DRIVE HUB SET	BV0935	1
PV0726	FLAT WASHER, d6xD10x0.3t	BK0931	2
	ONE WAY BEARING SHAFT	BK0930	1
PV0727	SET SCREW, M3x3	HME3-3B	4
	MAIN SHAFT LOCK RING	BK1020	2
PV0728	MOTOR MOUNT	BK1036	1
	SOCKET SCREW, M3x5	HSA3-5B	2
	SOCKET SCREW, M3x10	HMC3-10B	2
	LOCK NUT, M3	HMM3Z	2
PV0729	PINION 13T	BK1009	2
	SET SCREW, M3x3	HME3-3B	2
PV0730	SET SCREW, M3x3	HME3-3B	2
	PINION 10T	BK1013	2
PV0731	SET SCREW, M3x3	HME3-3B	2
	PINION 15T	BK1016	2
PV0732	TAIL BOOM BRACKET	BK1005	1
	TAIL BOOM BRACKET COVER	BK1006	1
	SELF TAPPING SCREW, M2x10	HMJ2-10N	2
	SOCKET SCREW, M2x10	HMC2-10B	2
	TAPPING SCREW (W/WASHER), M2x10	HNN2-10B	2
	SOCKET SCREW, M2x25	HMC2-25B	2
	HEX NUT, M2	HML2	4
PV0733	TAIL DRIVE GEAR	BV1007	1
PV0734	TAIL BOOM	BK1004	2
PV0735	TAIL ROTOR DRIVE BELT, MXL-3T	BK1073	1
PV0736	TAIL UNIT HOUSING	BK0988	1
	TAIL UNIT HOUSING COVER	BK0989	1
	TAPPING SCREW (W/WASHER), M2x10	HNN2-10B	6
PV0737	TAIL ROTOR SHAFT	PV0973	2
PV0738	TAIL P. CONTROL LEVER-1	BK0990	1
	TAIL P. CONTROL LEVER-2	BK0991	1
	TAIL P. CONTROL SLIDER	BV0993A	1
	DOUBLE JOINT LEVER	BK0992	1
	FLAT WASHER, d2xD3.8x0.5t	BK0919	2
	SOCKET SCREW, M2x16	HMC2-16B	2
	TAPPING SCREW (W/WASHER), M2x10	HNN2-10B	1
	LINKAGE BALL(∅3.8)	BK1203	1
	COUNTERSUNK SCREW, M1.6x6	HSP16-6N	1
PV0739	TAIL PITCH CONTROL LINK	BK1000	4
	SOCKET SCREW, M2x10	HMC2-10B	4
	FLAT WASHER, d2xD3.8x0.2t	BK0920	4

No.	NAME	Parts No.	Quantity
PV0740	TAIL PITCH HOUSING	BK0998	2
	WASHER, d2.1xD4.8xT1	BK1080	2
	SOCKET SCREW, M2*8	HMC2-8B	2
	SOCKET SCREW, M2x10	HMC2-10B	2
	FLAT WASHER, d2xD3.8x0.2t	BK0920	4
PV0741	TAIL ROTOR HUB	BK0972	1
	SET SCREW, M3x3	HME3-3B	1
PV0742	TAIL ROTOR	BK0961	2
PV0743	STABILIZER FIN	BK1085	1
	VERTICAL FIN	BK1001	1
	TAPPING SCREW (W/WASHER), M2x6	HNN2-6B	1
	TAPPING SCREW (W/WASHER), M2x10	HNN2-10B	2
PV0744	FLYBAR PADDLE	BK0941	2
PV0745	MAIN ROTOR BLADE, 315mm	BV1062	1
PV0746	SKID DAMPER	BK1038	4
PV0747	TAIL SERVO TRAY	BK0923	2
	TAPPING SCREW (W/WASHER), M2x10	HNN2-10B	2
PV0748	DOUBLE JOINT LEVER	BK0992	1
	SOCKET SCREW, M2x16	HMC2-16B	2
	FLAT WASHER, d2xD3.8x0.5t	BK0919	2
PV0749	TAIL P. CONTROL LEVER-1	BK0990	1
	TAIL P. CONTROL LEVER-2	BK0991	1
	TAPPING SCREW (W/WASHER), M2x10	HNN2-10B	1
	LINKAGE BALL(Ø3.8)	BK1203	1
	COUNTERSUNK SCREW, M1.6x6	HSP16-6N	1
PV0750	TAIL P. CONTROL SLIDER	BV0993A	1
PV0751	TAIL SUPPORT BRACKET	BK1026	1
	SOCKET SCREW, M2x16	HMC2-16B	1
	HEX NUT, M2	HML2	1
PV0752	TAIL SUPPORT	BV1027	2
	TAPPING SCREW (W/WASHER), M2x10	HNN2-10B	2
	SOCKET SCREW, M2x16	HMC2-16B	1
	HEX NUT, M2	HML2	1
PV0753	TAIL LINKAGE ROD	BK1071	2
	BALL LINK, Ø3.8x12mm	BK0922	4
PV0754	LINKAGE ROD, 1.3x7mm	BK1063	3
	LINKAGE ROD, 1.3x10mm	BK1064	2
	LINKAGE ROD, 1.3x24.5mm	BK1066	2
	LINKAGE ROD, 1.3x29mm	BK1065	2
PV0755	BALL LINK, Ø3.8x10mm	BK0932	2
	BALL LINK, Ø3.8x12mm	BK0922	12
PV0756	CANOPY	BK1087	1
	BODY	BK1076	1
	RUBBER GROMMET	BC1520	2
	TAPPING SCREW, M1.2x3	HMJ12-3B	3
PV0757	CANOPY	BK1087	1
	TAPPING SCREW, M1.2x3	HMJ12-3B	3
PV0758	BODY	BK1076	1
	RUBBER GROMMET	BC1520	2
PV0759	BLADE HOLDER	BK1043	1
PV0760	ANAEROBICS RETAINER, R48	BV1089	1
PV0761	ANAEROBICS THREADLOCKING, T22	BV1090	1
PV0762	TAIL ROD GUIDE	BK1082	2
	TAPPING SCREW, M1.2x6	HMJ12-6B	2
PV0763	LINKAGE BALL(Ø3.8)	BK1203	20
PV0764	COUNTERSUNK SCREW, M1.6x6	HSP16-6N	20
PV0765	RUBBER GROMMET	BC1520	6
PV0766	DECAL	JV0203	1

No.	NAME	Parts No.	Quantity	
PV0767	ANTENNA TUBE	BK1028	2	
	RUBBER TUBE, 10mm	BK1088	4	
PV0768	RUBBER BAND	BK0109	2	
	NYLON STRAP, 100mm	HNJ-1	5	
	NYLON STRAP, 200mm	HNJ-2L	2	
PV0769	THRUST BEARING, d4xD9x4	HMX0409	2	
PV0770	BEARING, d2xD5x2.5t	HMV520ZZW	10	
PV0771	BEARING, d4xD9x4t	HMV940ZZ	4	
PV0772	TAPPING SCREW (W/WASHER), M2x6	HNN2-6B	20	
PV0773	TAPPING SCREW (W/WASHER), M2x10	HNN2-10B	20	
PV0774	SHOULDERED SCREW, M2x9	HNU2-9Z	10	
	FLAT WASHER, d2xD3.8x0.2t	BK0920	10	
PV0775	SOCKET SCREW, M2x14	HMC2-14B	20	
PV0776	SOCKET SCREW, M2x16	HMC2-16B	20	
PV0777	SOCKET SCREW, M2x8	HMC2-8B	20	
PV0778	SOCKET SCREW, M2x10	HMC2-10B	20	
PV0779	SOCKET SCREW, M2x25	HMC2-25B	20	
PV0780	SOCKET SCREW, M3x3	HME3-3B	20	
PV0781	TAPPING SCREW (W/WASHER), M2x10	HNN2-10B	5	
	TAPPING SCREW (W/WASHER), M2x6	HNN2-6B	5	
	COUNTERSUNK SCREW, M1.6x6	HSP16-6N	5	
	SET SCREW, M3x3	HME3-3B	3	
	SHOULDERED SCREW, M2x9	HNU2-9Z	2	
	HEX NUT, M2	HML2	4	
	SHOULDERED SCREW, M2x6	HN2-6Z	2	
	TAPPING SCREW, M1.2x6	HMJ12-6B	4	
	FLAT WASHER, d2.8xD5x0.5t	HMO26	2	
	FLAT WASHER, d2xD3.8x0.5t	BK0919	4	
	FLAT WASHER, d2xD3.8x0.2t	BK0920	4	
	COLLAR	BK1079	2	
	SAFETY WASHER	BK1080	2	
	PV0782	SOCKET SCREW, M2x14	HMC2-14B	4
		SOCKET SCREW, M2x16	HMC2-16B	4
		SOCKET SCREW, M2x8	HMC2-8B	4
SOCKET SCREW, M2x10		HMC2-10B	4	
SOCKET SCREW, M2x25		HMC2-25B	2	
SOCKET SCREW, M3x5		HSA3-5B	2	
SOCKET SCREW, M3x10		HMC3-10B	2	
SOCKET SCREW, M3x20		HMC3-20B	2	

E325 OPTIONAL PARTS



PV0801
METAL M. ROTOR HUB



PV0802
HARDENED MAIN SHAFT

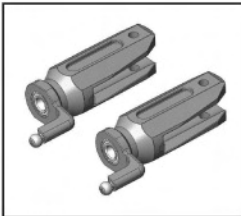

PV0803
METAL ROTOR GRIP

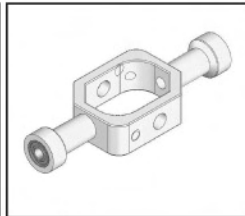

PV0804
METAL SEESAW HUB

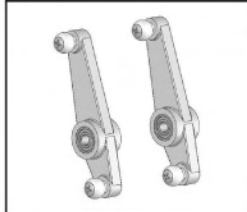

PV0805
METAL MIXING LEVER

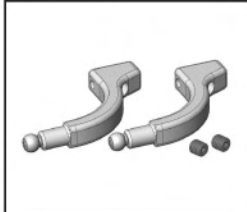

PV0806
M. FLYBAR C. ARM



PV0807
M. FLYBAR C. LEVER



PV0808
METAL WASHOUT BASE

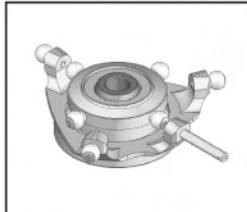

PV0809
METAL SWASHPLATE

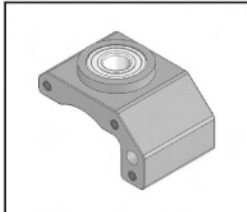

PV0810
METAL BRG BLOCK

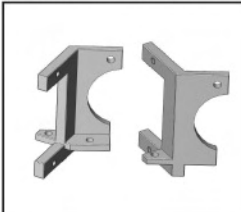

PV0811
METAL SERVO TRAY



PV0814
METAL PULLEY



PV0815
M. T. DRIVE PINION

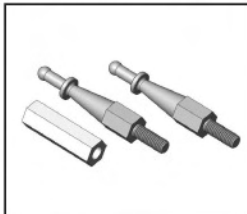

PV0816
M.BODY POST



PV0818
M. T. PITCH LEVER



PV0819
M. D. JOINT LEVER



PV0820
M. TAIL P. Control Set

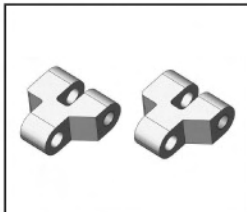

PV0821
M. T. PITCH LINK



PV0823
M. TAIL P. HOUSING



PV0824
CARBON TAIL FIN

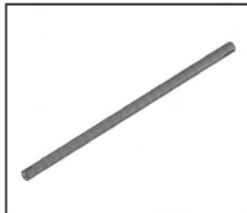

PV0825
CARBON TAIL BOOM



PV0826
CARBON MAIN BLADES



PV0827
SUS FLYBAR ROD

E325 ACCESSORIES



8117
ACE MICRO SERVO , C1016



8131
ACE MICRO SERVO , C0915



2381
BL. MOTOR, OBL 29/35-10H

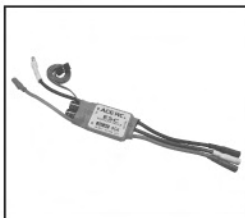

8041-H
SPEED CONTROL, ACE BLC-40



2808
LIPO BATT, 3S1P/2200mAh/20C



2809
LIPO BATT, 2S1P/2200mAh/20C



2532
Li-Po Battery E-Charger ELC 4



8041-H
SPEED CONTROL, ACE BLC-40



2808
LIPO BATT, 3S1P/2200mAh/20C



2809
LIPO BATT, 2S1P/2200mAh/20C



SPECIFICATION

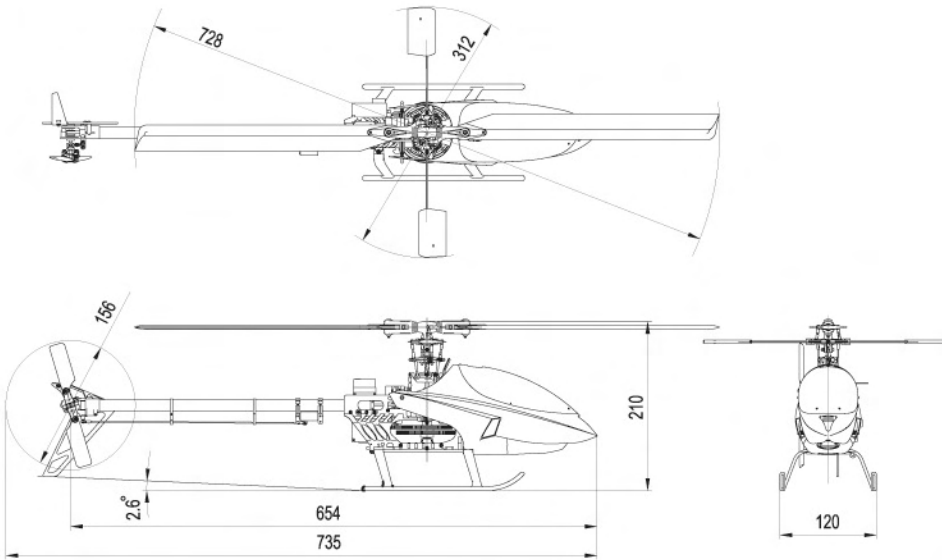

Fuselage length: 654 mm (25.74 in)

Fuselage width: 120mm (4.72 in)

Total height: 210mm (8.3 in)

Main rotor dia.: 728mm (28.66 in) / Max.748mm (29.45 in)

Tail rotor dia.: 156mm (6.14 in)

Gear ratios: 1 : 10 : 4.4

1 : 11.5 : 4.4

1 : 15 : 4.4

Full equipped weight: 750g (26.5 oz)

FEATURES

1. Super strong and light weight one-piece main frame
2. Molded one-piece landing Skid
3. Easily accessible and removable motor to change pinions
4. High-positioned battery tray for better aerobatics
5. Changeable Bell-Hiller mixing ratio for different flying styles
6. 1200 e-CCPM Control System
7. Main rotor grips with two radials and a thrust bearing
8. Driven-tail autorotation system
9. Entire tail assembly detaches unplugs for easy packing and storing
10. Precise tail pitch control system



THUNDER TIGER CORPORATION

www.thundertiger.com

© 2006

JK0201 V2

Printed in Taiwan