

EP-HELICOPTER
T-REX 450XL CCPM
INSTRUCTION MANUAL



- ★ 35 Precision Bearings
- ★ Auto-Rotation System
- ★ Rear Tail Servo Mount
- ★ Collective Pitch System
- ★ Tail Rotor Drive Belt System
- ★ Main Drive Gear with Cooling Fan
- ★ Professional Servo Control Lever Design

Contents

1~2	Safety Notes
3~10	Assembly Section
11~13	Adjustment Section
14~15	Regular Maintenance
15~17	Spare Parts and Tools

Thank you for buying **ALIGN** products. The **T-REX 450XL** is the latest technology in Rotary RC models. Please read this manual carefully before assembling and flying the new **T-REX 450XL** helicopter. We recommend that you keep this manual for future reference regarding tuning and maintenance.

Thank you for buying ALIGN Products. The T-REX 450XL Helicopter is designed as easy to use, full featured Helicopter R/C model capable of all forms of rotary flight. Please read the manual carefully before assembling the model, and follow all precautions and recommendations located within the manual. Be sure to retain the manual for future reference, routine maintenance, and tuning. The T-REX 450XL is a new product developed by ALIGN. It features the best design available on the Micro-Heli market to date, providing flying stability for beginners, full aerobic capability for advanced fliers, and unsurpassed reliability for customer support.

IMPORTANT NOTES

R/C helicopters, including the T-REX 450XL are not toys. R/C helicopters utilize various high-tech products and technologies to provide superior performance. The rotating blades on the model spin at high speed and can cause potential risk or injury if used improperly. It is mandatory that you observe all R/C safety rules and adhere to local laws as applicable. We recommend that you contact your local hobby store and inquire about safety, rules, regulations, and local laws and statutes regarding R/C model operation in your area. Please make sure to be conscious of your own personal safety and the safety of others and your environment when operating all ALIGN products. When used properly, ALIGN R/C products will provide years of R/C entertainment.

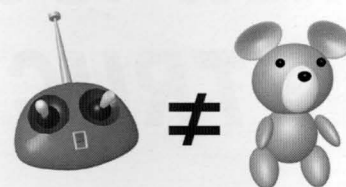

It is not a Toy!

We recommend that you obtain the assistance of an experienced pilot before attempting to fly our products for the first time. A local expert is the best way to properly assemble, setup, and fly your model for the first time.

The T-REX 450XL requires a certain degree of skill to operate, and is a consumer item. Any damage or dissatisfaction as a result of accidents or modifications are not covered by any warranty and cannot be returned for repair or replacement. Please contact our distributors for free technical consultation and parts at discounted rates when you experience problems during operation or maintenance.

Note: Fly only in safe areas, away from other people. Do not operate R/C aircraft within the vicinity of homes or crowds of people. R/C aircraft are prone to accidents, failures, and crashes due to a variety of reasons including, lack of maintenance, pilot error, and radio interference. Pilots are responsible for their actions and damage or injury occurring during the operation or as a result of R/C aircraft models.

SAFETY NOTES

1. Locate an appropriate location:

R/C helicopters fly at high speed, thus posing a certain degree of potential danger. Choose an appropriate flying site consisting of flat, smooth ground, a clear open field, or a large open room, such as a gymnasium or warehouse without obstacles. Do not fly near buildings, high voltage cables, or trees to ensure the safety of yourself, others, and your model. Do not fly your model in inclement weather, such as rain, wind, snow, or darkness.



2. Obtain the assistance of an experienced pilot:

Before turning on your model and transmitter, check to make sure no one else is operating on the same frequency. Frequency interference can cause your model, or other models to crash. The guidance provided by an experienced pilot will be invaluable for the assembly, tuning, trimming, and actual first flight. (Recommend you to practice with simulated flying software.)

3. Always be aware of the rotating blades:

During the operation of the helicopter, the main rotor and tail rotor will be spinning at a high rate of speed. The blades are capable of inflicting serious bodily injury and damage to the environment. Be conscious of your actions, and careful to keep your face, eyes, hands, and loose clothing away from the blades. Always fly the model a safe distance from yourself and others, as well as surrounding objects. Never take your eyes off the model or leave it unattended while it is turned on. Immediately turn off the model and transmitter when you have landed the model.

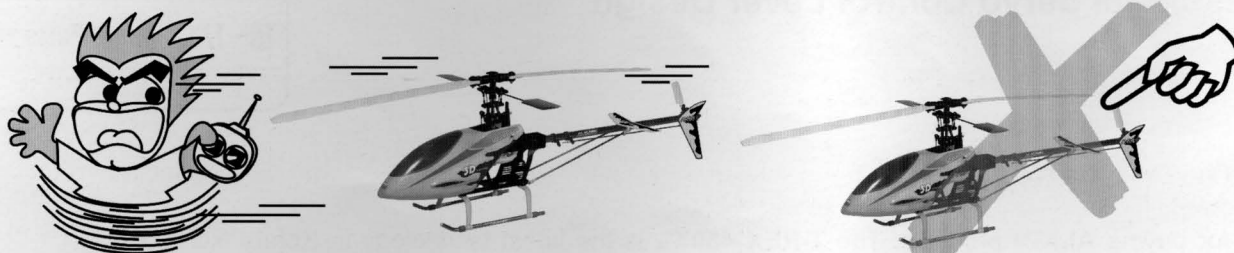

PREVENT MOISTURE

R/C models are composed of many precision electrical components.

It is critical to keep the model and associated equipment away from moisture and other contaminants.

The introduction or exposure to water or moisture in any form can cause the model to malfunction resulting in loss of use, or a crash.

Do not operate or expose to rain or moisture.



KEEP AWAY FROM HEAT

R/C models are made up various forms of plastic.



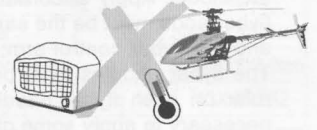

Plastic is very susceptible to damage or deformation due to heat.

Make sure not to store the model near any source of heat such as an oven, or heater.



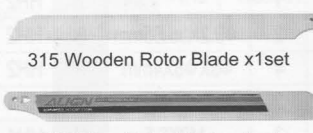

It is best to store the model indoors, in a climate-controlled, room temperature environment.

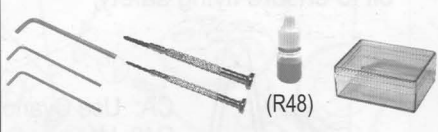

STANDARD EQUIPMENT

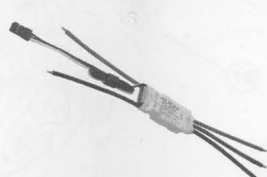
- | | | | |
|---|--|---|---|
|  <p>1 T-REX 450XL EP-Helicopter Kit x1set</p> |  <p>315 Wooden Rotor Blade x1set
325 Fiber Rotor Blade x1set</p> <p>2 Rotor Blade x2sets</p> |  <p>3 Decal x1pc</p> | |
|  <p>4 Hook & Loop Fastening Tape x1pc
Main Rotor Fixing x1pc</p> |  <p>5 Main Gear x4pcs
 $\varnothing 2.3 \times 11T \times 1$
 $\varnothing 3.17 \times 11T \times 1$
 $\varnothing 3.17 \times 13T \times 1$
 $\varnothing 3.17 \times 15T \times 1$
 M3x3 Set Screw x1</p> |  <p>6 Hardware Bag x1pc</p> |  <p>7 Tools x7pcs
(Hexagon wrenchs, screw drivers, anergobics retainer, parts case x1pc)
(R48)</p> |

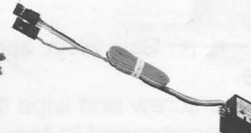



RADIO TRANSMITTER AND ELECTRONIC EQUIPMENT REQUIRED FOR ASSEMBLY

- | | | | | |
|--|---|--|---|---|
|  <p>Transmitter
(6-channel, helicopter system)</p> |  <p>Electronic Speed Controller
(25A or more)</p> |  <p>Receiver
(6-channel or more)</p> |  <p>Gyro</p> |  <p>9g Micro Servo x3pcs
6g Micro Servo x1pc</p> |
|--|---|--|---|---|

POWER SYSTEM REQUIRED FOR ASSEMBLY

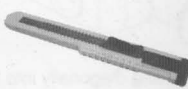
- | | | |
|---|---|---|
| <p>Motor Gear Ratio:
(4000-4200KV with 9T)
(3500-3800KV with 11T)
(2800-3000KV with 13T)
(2300-2500KV with 15T)</p> |  <p>400 Brushless Motor</p> |  <p>Battery DC11.1V
(Discharge Current: 15A and more)</p> |
|---|---|---|

TOOLS REQUIRED FOR ASSEMBLY

- | | | | | | |
|--|---|--|---|---|---|
|  <p>Scissors</p> |  <p>Cutter Knife</p> |  <p>Lubricant</p> |  <p>Quick Dry Glue</p> |  <p>Nipper</p> |  <p>Ball Link Pliers</p> |
|--|---|--|---|---|---|

Each section of the manual has its associated parts bag. Each bag is labeled accordingly. Make sure to only open the bags as indicated in the instructed manual and place them into the provided parts cases. Do not open all the bags at once, or out of order to avoid confusion and difficulty assembling the model.

Start assembling the model by beginning with the main rotor head. We will build the model from the rotor head, out to the rest of the model. Apply silicon lubricant in the inside and outer edges of the o-rings, then insert them into the main rotor head. The flybar ends must be the same length on each side of the rotor head. Measure the distance between the edge of the flybar paddle and the flybar control arm; make this distance the same on both sides. The flybar control arms must be parallel to each other. The flybar paddles must be locked in the same position, exactly horizontally level with the swashplate. Use an angle of attack ruler on each flybar paddle and adjust the angles so that they are the same, and have the correct angle. It may become necessary to apply some glue on the screws to properly tighten them. The screws must be tightened snugly, but be careful to not overtighten them as it will strip the threads and cause the assembly to become loose.

Note: After tightening the flybar control arms and paddles, check for free movement and minimal gaps between the surfaces. All rotor head assemblies should be assembled tightly snug, without any binding or slow movement.

Parts kit No. HH

No.	PN.	Parts No.	Description	Q'TY	Specification	No.	PN.	Parts No.	Description	Q'TY	Specification
1	HH2	HH2002-1	Main rotor housing	1		7	HH2	HH2011L	Head stopper	1	
2	HH2	HH2006-2	Main rotor holder	2	Φ8.2X36.65mm	8	HH2	T12006	Screw	1	M2X6
3	HH2	H693ZZ	Bearing 693ZZ	4	Φ3XΦ8X4mm	9	HH2	HH2003-1	Pin	2	Φ1.5X18.7mm
4	HH2	HH4006	Linkage ball	2	Φ4.75	10	HH4	HH4002-2	Flybar seesaw holder	1	36X14.6X6mm
5	HH2	HS4001-1	Cross screw	2	M2X6.5	11	HH4	HH4010	Collar	2	Φ3XΦ5X2mm
6	HH2	HMR63ZZ	Bearing MR63ZZ	2	Φ3XΦ6X2.5mm	12	HH4	HS6001	Collar screw	2	M2X7

When you see the marks as below, please use glue or oil to ensure flying safety.

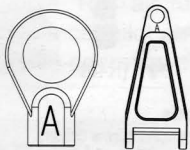

CA: Use Cyanoacrylate Adhesive to fix.
R48: Use anaerobics retainer to fix.
OIL: Add lubricant

When assembling ball links, make sure the "A" character faces outside.

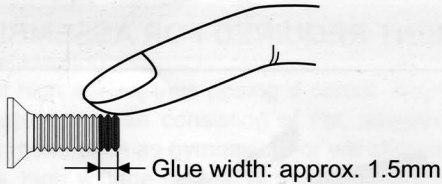

R48 is very adhesive. Apply a little R48 on the screw and wipe surplus off. When disassembling, recommend to toast the metal joint about 15 seconds.

(NOTE: Keep plastic parts away from heat.)

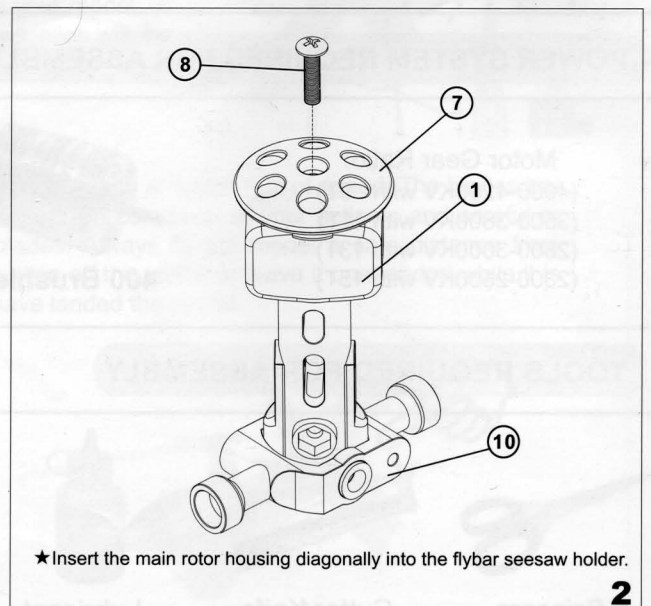
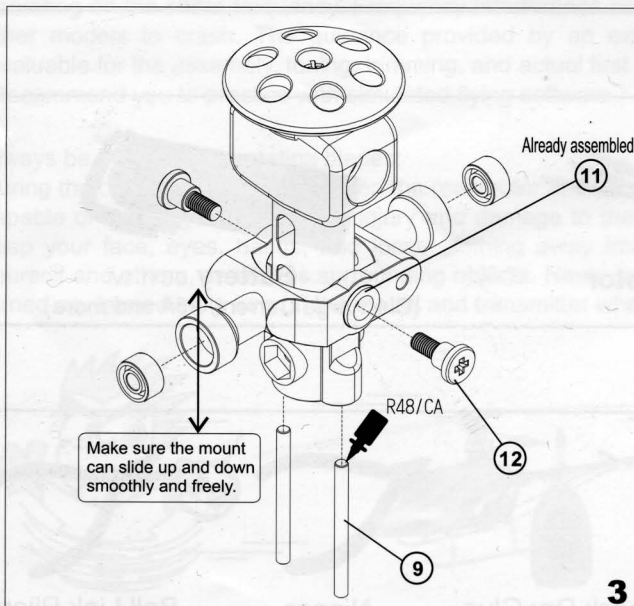
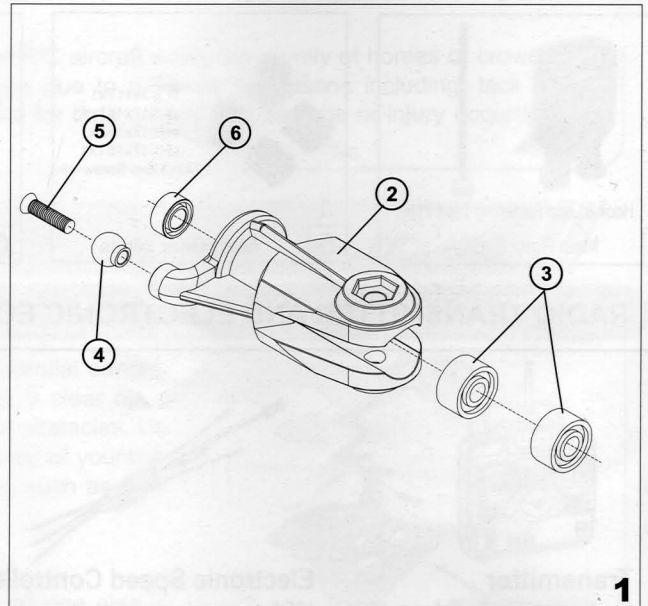

Parts kit No. HH

No.	PN.	Parts No.	Description	Q'TY	Specification	No.	PN.	Parts No.	Description	Q'TY	Specification
13	HH3	HH3009	PA Fiber rotor blade	2	325mm	25	HH4	HS5001	Set screw	2	M3X3
14	HH3	HH3003	Blade collar	2	φ3	26	HH4	S72005-3	Cross screw	4	M2X5
15	HH3	HS3002	Socket screw	2	M3X16	27	HH4	W10020-2	Washer	2	φ2Xφ3.8X0.5mm
16	HH3	HS7002	Nut	2	M3	28	HH4	W10020-1	Washer	4	φ2Xφ3.8X0.2mm
17	HH4	HH4003	Flybar rod	1	φ1.97X190mm	29	HH2	HH2004	O-Ring	4	φ3Xφ6.5X2
18	HH4	HH4009	Flyar paddle-3K	2		30	HH2	HH2005-1	Aluminum collar	2	φ3Xφ5X1.5mm
19	HH4	HH4005A-3	SF mixing lever	2	31.45X5.5mm	31	HH2	HH2007	Feathering shaft	1	φ3X40mm
20	HH4	HMR52ZZ	Bearing MR52ZZ	6	φ2Xφ5X2.5mm	32	HH2	HS8001	Washer	2	φ2Xφ5X0.4mm
21	HH4	HH4006	Linkage ball	4	φ4.75	33	HH2	HS3001	Socket screw	2	M2X5
22	HH4	HS4001-1	Cross screw	4	M2X6.5	34	HH6	HH6002-2	Main shaft	1	φ5X116
23	HH4	T12009	Collar screw	2	M2X9	35	HH6	HH6003	Main shaft lock ring	1	φ5X6
24	HH4	HH4007L	Flybar control set	1		36	HH6	HS5001	Set screw	1	M3X3

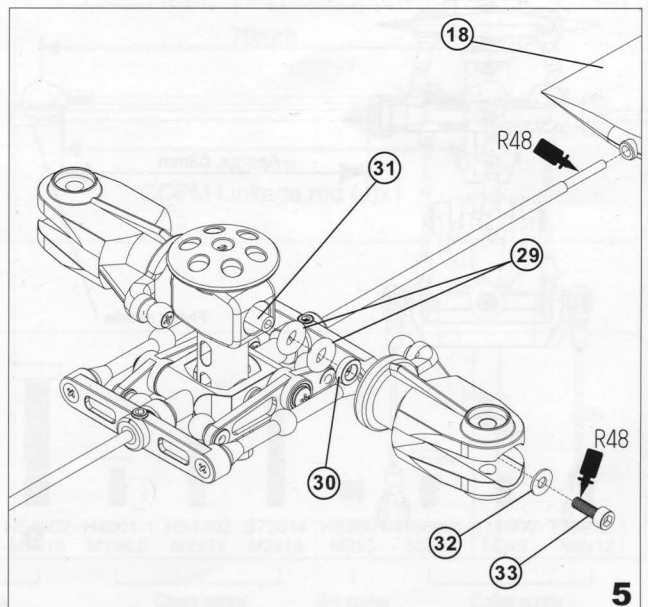
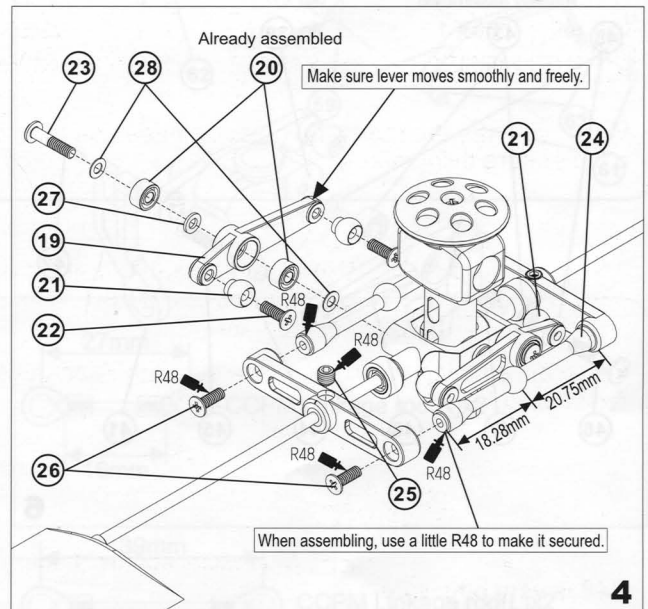
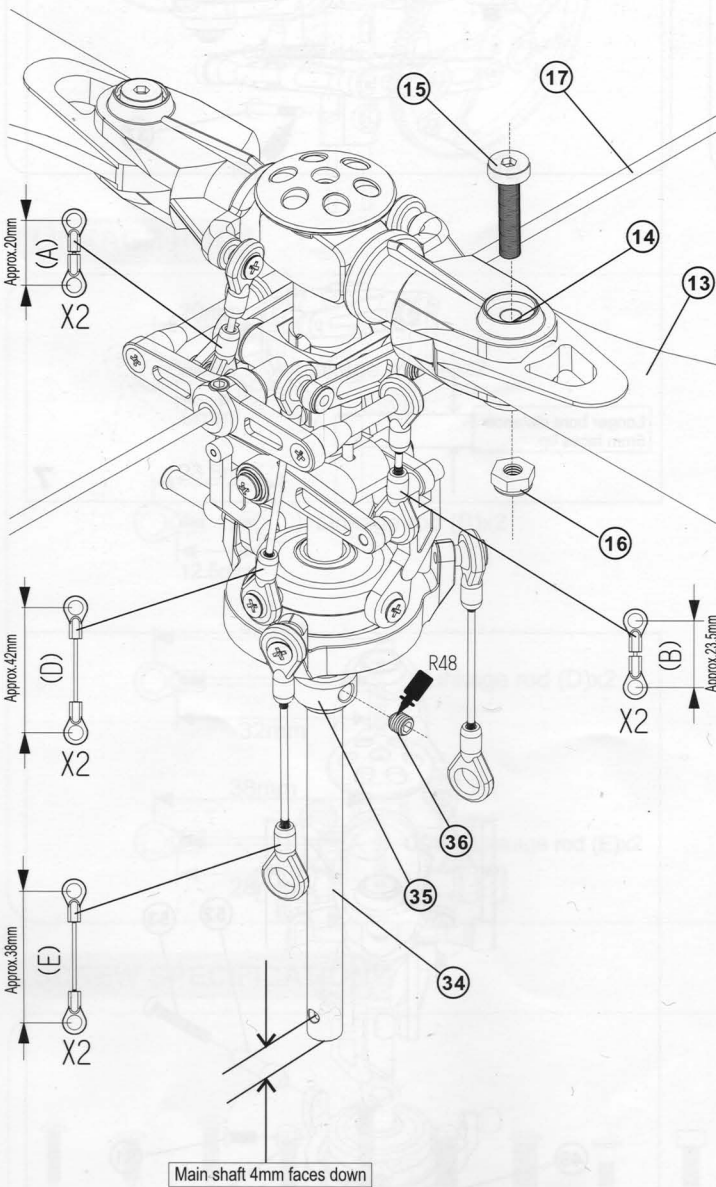

Parts kit No. HH

No.	PN.	Parts No.	Description	Q'TY	Specification	No.	PN.	Parts No.	Description	Q'TY	Specification
37	HH2	T52012	Socket screw	1	M2X12	46	HH5	T12009	Collar screw	2	M2X9
38	HH2	HS7001	Nut	1	M2	47	HH5	W10020-2	Washer	2	φ2Xφ3.8X0.5mm
39	HH5	HH5002-2	Washout base	1	φ5X10	48	HH5	W10020-1	Washer	4	φ2Xφ3.8X0.2mm
40	HH5	HH5003A-3	Flybar control lever	2		49	HH5	HS1090	CCPM Swashplate	1	φ26x11.5mm
41	HH5	HH5003B-2	Washout linkage	2		50	HH5	HH4006	Linkage ball	6	φ4.75
42	HH5	HH5003C-2	Pin	2	φ1.1X7	51	HH5	HS4001-1	Cross screw	6	M2X6.5
43	HH5	HMR52ZZ	Bearing MR52zz	4	φ2Xφ5X2.5mm	52	HH7	HH4011	Long linkage ball	1	φ4.75X11.5mm
44	HH5	HH4006	Linkage ball	2	φ4.75	53	HH7	S72014	cross screw	1	M2X14
45	HH5	HS4001-1	Cross screw	2	M2X6.5						

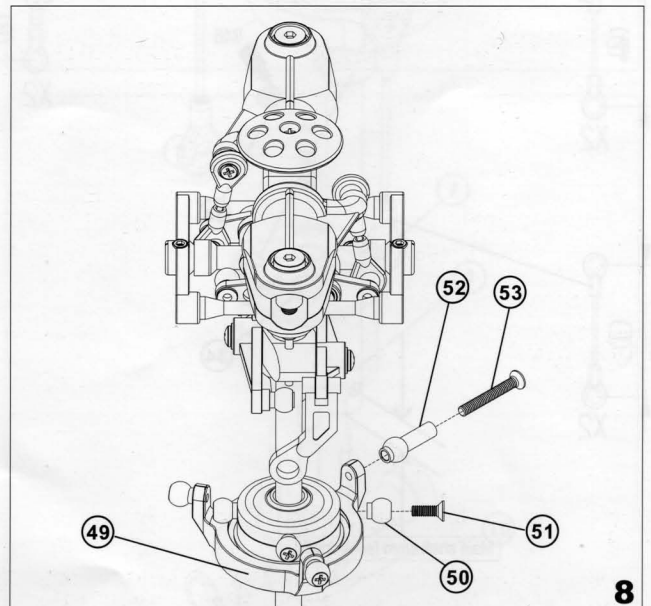
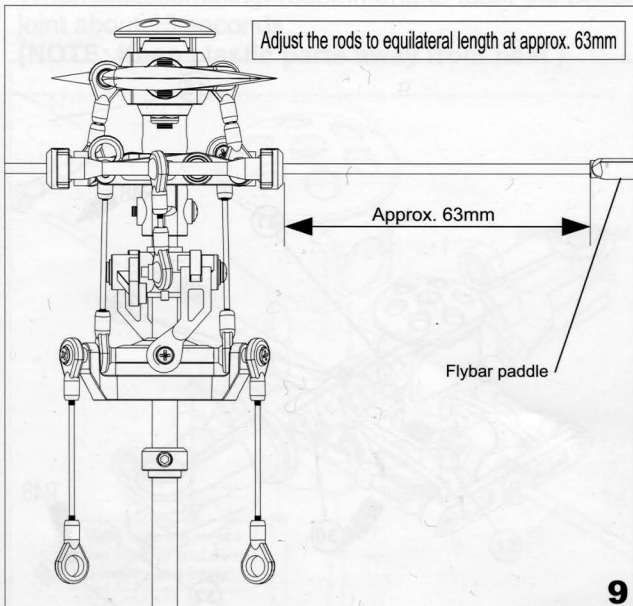
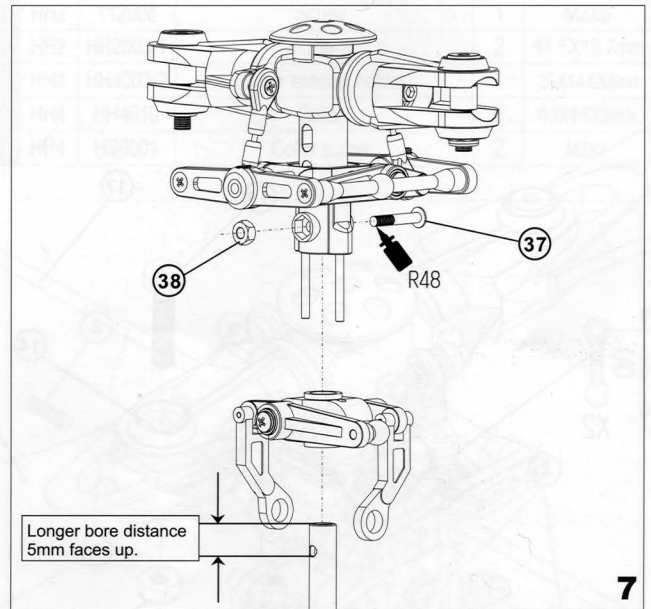
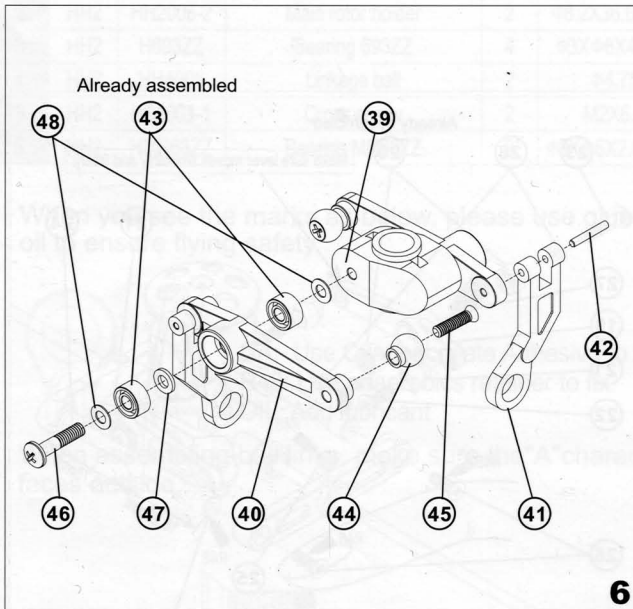

Parts kit No. HB·HF

No.	PN.	Parts No.	Description	Q'TY	Specification	No.	PN.	Parts No.	Description	Q'TY	Specification
54	HB6	HB6001A-2	Main drive gear	1	150T	59	HF2	HF2002-1	Landing skid	2	
55	HB6	HF0612	One way bearing	1	φ6X10X12mm	60	HF2	HF2003	Skid pipe	2	Aluminum
56	HB6	HB6002	One way bearing shaft	1	φ6X21.5	61	HF2	HF2004	Skid pipe end cap	4	φ4.5X5.75
57	HB6	HB6003	Shaft ring	1	φ6X1.5	62	HF2	HF2007	Antenna pipe	1	φ3X300mm
58	HB6	HB6001B-1	Autorotation tail drive gear	1	109T	63	HF2	K10181-1	Landing skid nut	4	φ8.5Xφ5X10mm

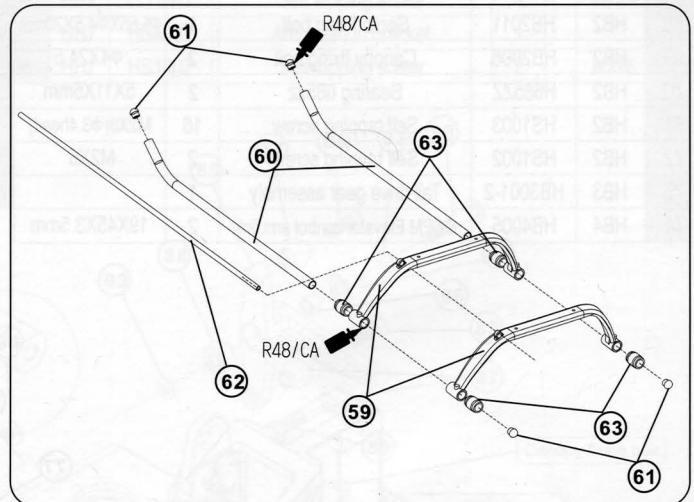
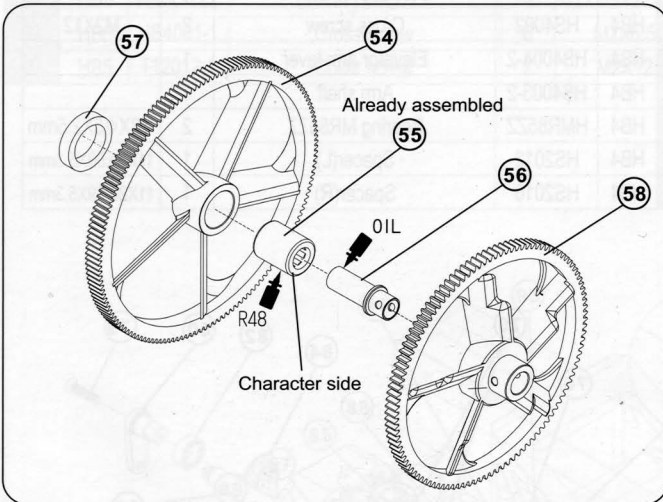

LINKAGE ROD

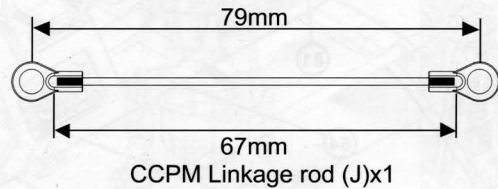
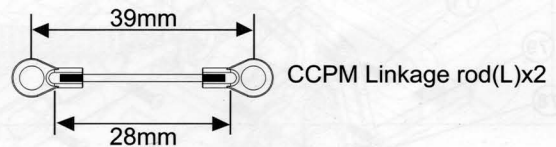
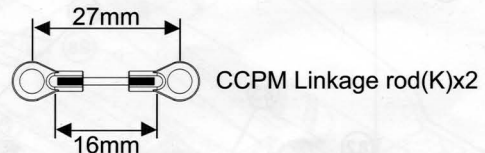
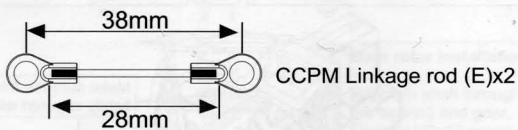
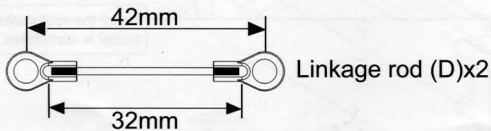

SCREW SPECIFICATION



The screws must be firmly tightened, but not over tightened, or they will strip and become loose. Use "Blue" Loctite or Threadlock where screws are tightened into metal objects.

Parts kit No. HB·HF

No.	PN.	Parts No.	Description	Q'TY	Specification	No.	PN.	Parts No.	Description	Q'TY	Specification
64	HB2	HB2002L	Main frame (L)	1		75	HB4	HB4006	CCPM Elevator control arm	1	24.3X44.5mm
65	HB2	HB2003L	Main frame (R)	1		76	HB4	HS2004	Screw	2	M2.6X6
66	HB2	HB2009	CCPM Servo frame	1		77	HB4	HS8002	Washer	2	M2.6
67	HB2	HB2005	Frame fixing bolt	1	Φ4.5X20	78	HF2	HS1002	Self tapping screw	4	M2X6
68	HB2	HB2011	Servo fixing bolt	1	Φ1.65XΦ4.5X20mm	79	HB4	HS4002	Cross screw	2	M2X12
69	HB2	HB2006	Canopy fixing bolt	2	Φ4X24.5	80	HB4	HB4004-2	Elevator arm lever	1	
70	HB2	H685ZZ	Bearing 685zz	2	5X11X5mm	81	HB4	HB4003-2	Arm shaft	1	
71	HB2	HS1003	Self tapping screw	16	M2X8(Φ3.4head)	82	HB4	HMR85ZZ	Bearing MR85ZZ	2	Φ8XΦ5X2.5mm
72	HB2	HS1002	Self tapping screw	2	M2X6	83	HB4	HS2012	Spacer(L)	1	11X20.59X5.3mm
73	HB3	HB3001-2	Tail drive gear assembly	1		84	HB4	HS2010	Spacer(R)	1	11X20.59X5.3mm
74	HB4	HB4005	CCPM Elevator control arm link	2	19X45X3.5mm						

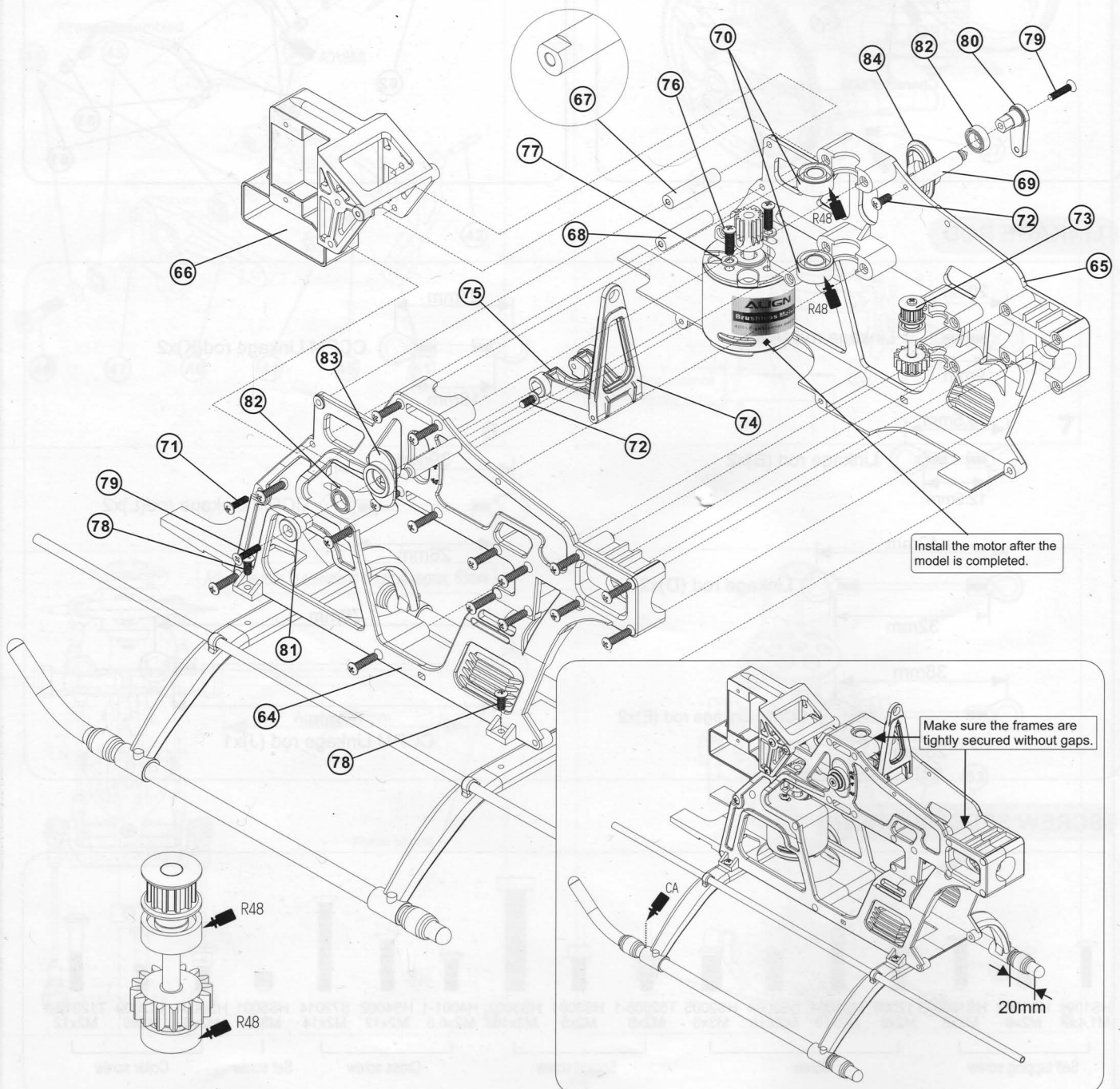

The screws must be firmly tightened, but not over tightened, or they will strip and become loose. Use "Blue" Loctite or Threadlock where screws are tightened into metal objects.

Parts kit No. HB

No.	PN.	Parts No.	Description	Q'TY	Specification	No.	PN.	Parts No.	Description	Q'TY	Specification
85	HB5	HB5008	T-type control lever	2	Φ3X2.5	91	HB6	T52012	Socket screw	1	M2X12
86	HB5	HB5009	Aluminum collar	2	Φ2XΦ3X2mm	92	HB6	HS7001	Nut	1	M2
87	HB5	HB4006	Linkage ball	6		93	HB5	W10020-1	Washer	4	Φ2XΦ3.8X0.2mm
88	HB5	HMR52ZZ	Bearing MR52ZZ	4	Φ2XΦ5X2.5mm	94	HB2	HS1003	Self tapping screw	4	M2X8
89	HB5	HS4001-1	Cross screw	6	M2X6.5	95	HH7	HB4007	Anti rotation bracket	1	
90	HB5	T12012-1	Collar screw	2	M2X12	96	HH7	HS1002	Self tapping screw	2	M2X6

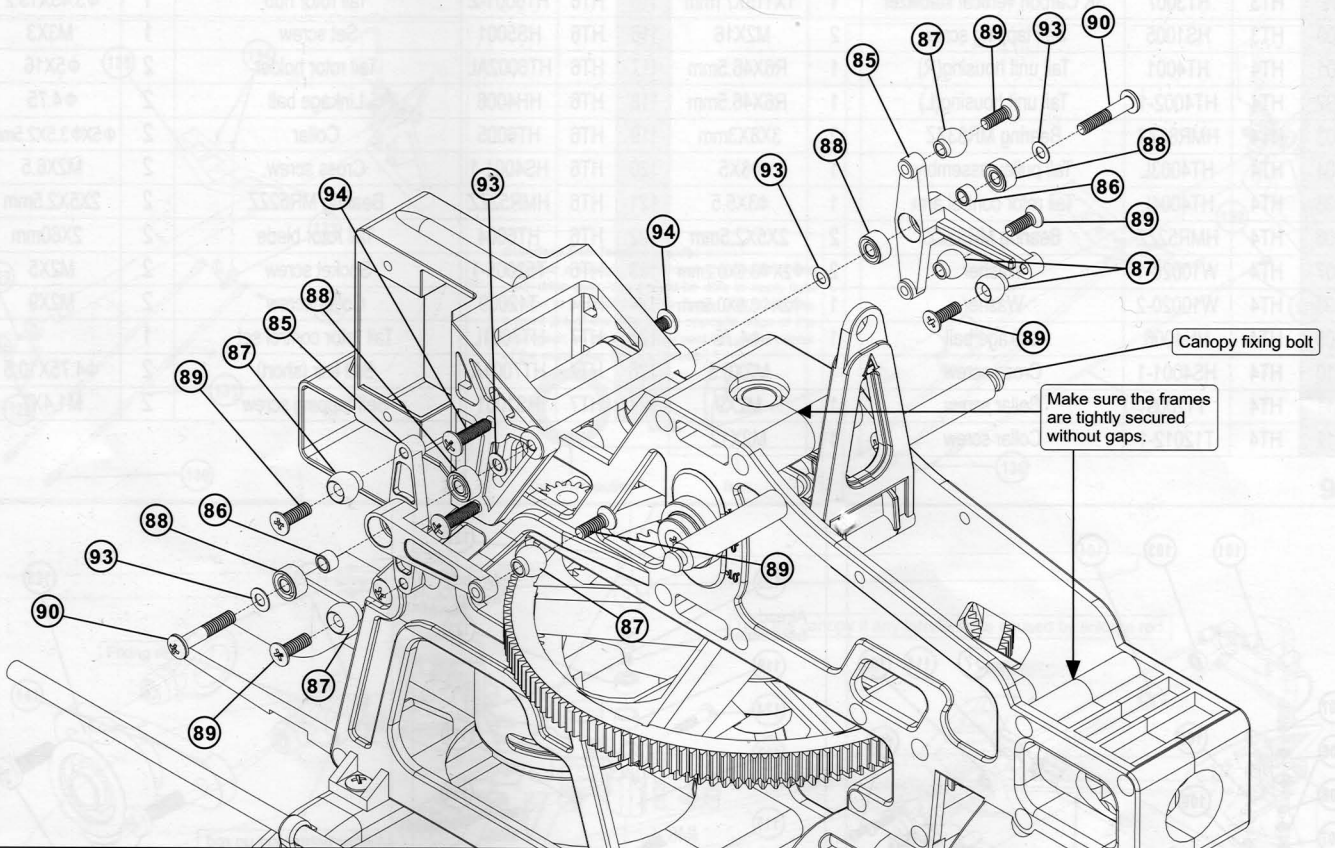

Make sure the frames are tightly secured without gaps.

Canopy fixing bolt

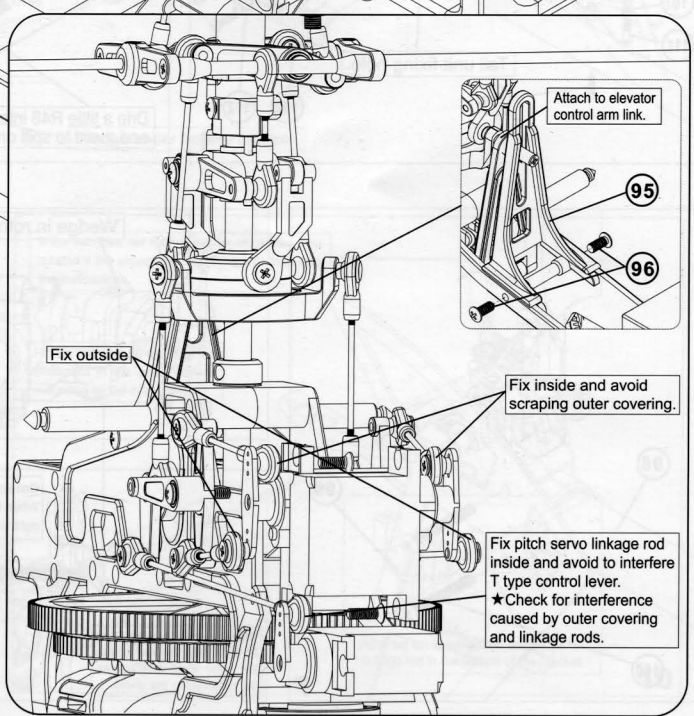
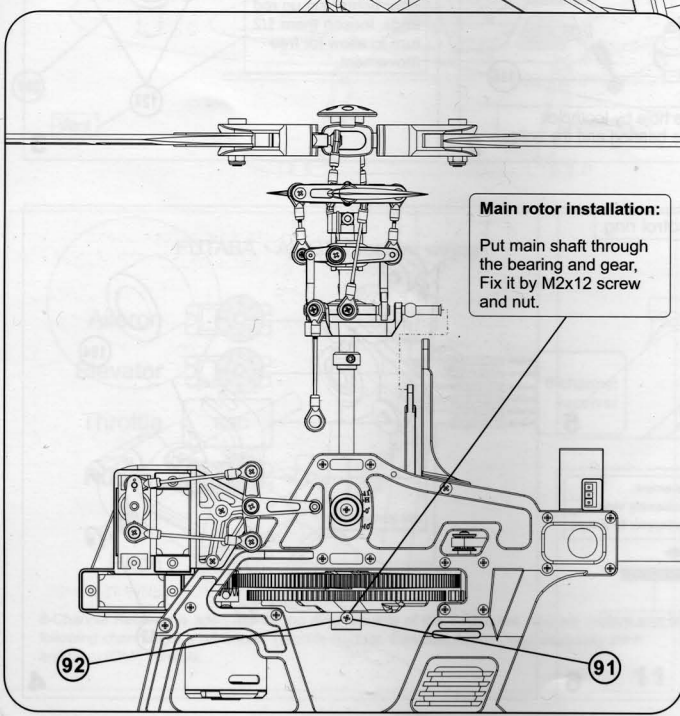

Follow the instructions carefully and in order. Look for key points on each procedure.

- 1.The set screw on the tail rotor housing must point towards the tail rotor blades and be tightened firmly.
- 2.When assembling the tail boom and fuselage, make sure to turn the belt 90 degrees as illustrated in the diagram 10. Mount the belt around the drive pulley, mount the other half of the tail case and tighten it, leaving it loose enough to rotate on the boom with some effort. Adjust belt tension by moving the tail case further back on the boom. Once the belt has the proper tension, make sure the tail rotor blades are perpendicular to the ground when looking at the helicopter from behind. Tighten the screws to lock into this position. Check often and re-adjust as needed.

Parts kit No. HT

No.	PN.	Parts No.	Description	Q'TY	Specification	No.	PN.	Parts No.	Description	Q'TY	Specification
97	HT1	HT1003	Tail rotor drive belt	1	397T	113	HT4	HS1004	Self tapping screw	3	M2X10
98	HT2	HT2004	Tail boom	1	Φ12X347	114	HT5	HT5001L	Tail rotor shaft assembly	1	Φ3
99	HT3	HT3007	3K Carbon vertical stabilizer	1	1X115X71mm	115	HT6	HT6001-2	Tail rotor hub	1	Φ3.45X13.2
100	HT3	HS1005	Self tapping screw	2	M2X16	116	HT6	HS5001	Set screw	1	M3X3
101	HT4	HT4001	Tail unit housing(R)	1	R6X46.5mm	117	HT6	HT6002AL	Tail rotor holder	2	Φ5X16
102	HT4	HT4002-1	Tail unit housing(L)	1	R6X46.5mm	118	HT6	HH4006	Linkage ball	2	Φ4.75
103	HT4	HMR83ZZ	Bearing MR83ZZ	2	3X8X3mm	119	HT6	HT6005	Collar	2	Φ5XΦ3.5X2.5mm
104	HT4	HT4003L	Tail pulley assembly	1	Φ8X5	120	HT6	HS4001-1	Cross screw	2	M2X6.5
105	HT4	HT4004L	Tail rotor control arm	1	Φ3X5.5	121	HT6	HMR52ZZ	Bearing MR52ZZ	2	2X5X2.5mm
106	HT4	HMR52ZZ	Bearing MR52ZZ	2	2X5X2.5mm	122	HT6	HT6004	Tail rotor blade	2	2X60mm
107	HT4	W10020-1	Washer	2	Φ2XΦ3.8X0.2mm	123	HT6	T52005-1	Socket screw	2	M2X5
108	HT4	W10020-2	Washer	1	Φ2XΦ3.8X0.5mm	124	HH4	T12009	Collar screw	2	M2X9
109	HT4	HH4006	Linkage ball	1	Φ4.75	125	HT7	HT7001L	Tail rotor control set	1	
110	HT4	HS4001-1	Cross screw	1	M2X6.5	126	HT7	HT7001A	Ball link (short)	2	Φ4.75X10.5
111	HT4	T12009	Collar screw	1	M2X9	127	HT7	HS1001	Self tapping screw	2	M1.4X7
112	HT4	T12012-1	Collar screw	1	M2X12						

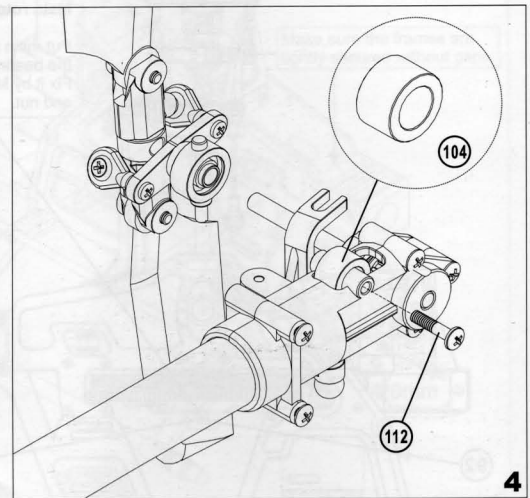
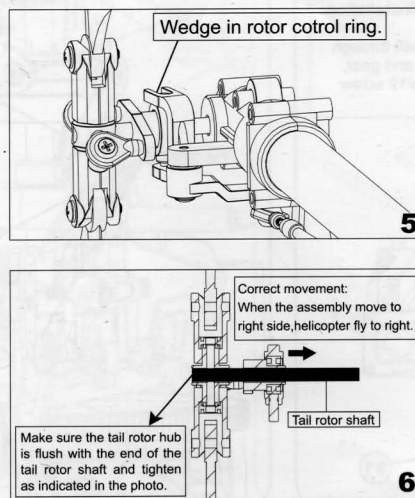
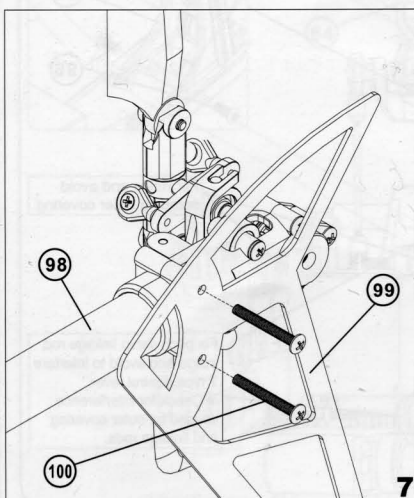
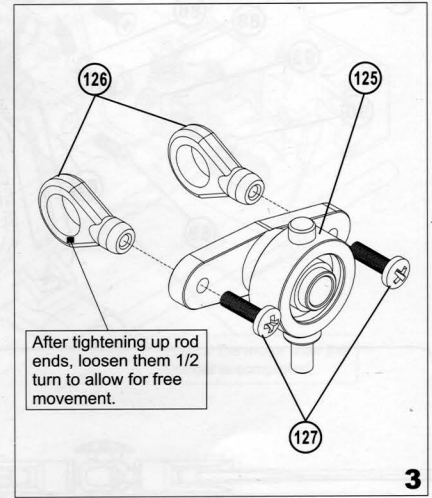
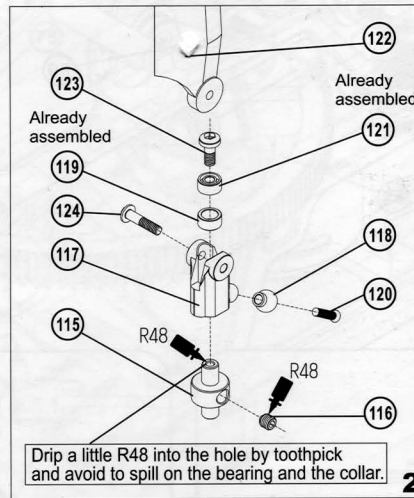
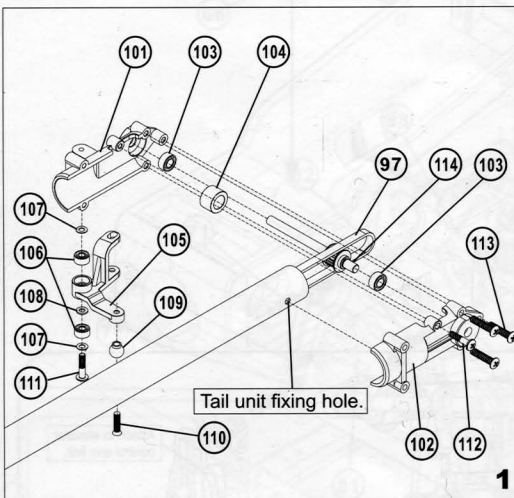

Parts kit No. HT

No.	PN.	Parts No.	Description	Q'TY	Specification	No.	PN.	Parts No.	Description	Q'TY	Specification
128	HT2	HT2002	Tail servo mount	2		135	HT3	HT3002	Horizontal stabilizer	1	
129	HT2	HS1003	Self tapping screw	4	M2X8(φ3.4head)	136	HT9	HT9001C	L-type linkage rod	1	φ1.3X16mm
130	HT2	HT2003A	Tail boom brace terminal	4		137	HT9	HT9001A	Tail linkage rod	1	φ2X250mm
131	HT2	HT2003B	Tail boom brace	2	φ2X250mm	138	HT9	HZ002	Linkage rod(B)	1	φ1.3X12.5mm
132	HT2	HS1002	Self tapping screw	2	M2X6	139	HT9	HZ009	Ball link (Long)	1	
133	HT3	HT3003	Bracket	1		140	HB8	HB8005	Canopy	1	
134	HT3	HS1002	Self tapping screw	2	M2X6	141	HB8	HB8006	Canopy cover	1	

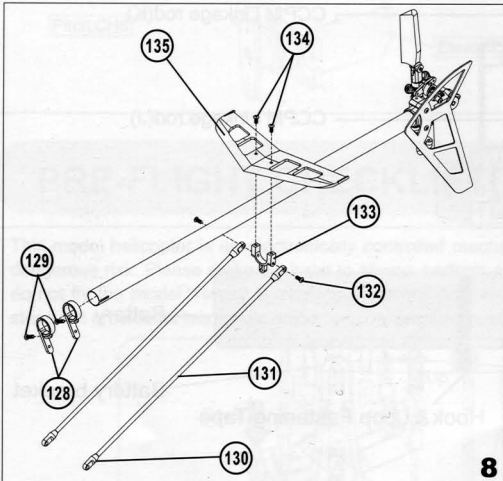

8

Standard Belt Tension Guide:

Visualize a straight line through the center of the main drive gear. You should be able to apply light tension to the belt with your finger until it reaches a point 3/4 of the way to the opposite edge of the main gear, or 1/4 of the way past the virtual center of the main gear. Refer to photo.

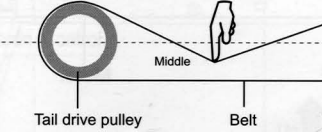

Tail drive pulley

Belt

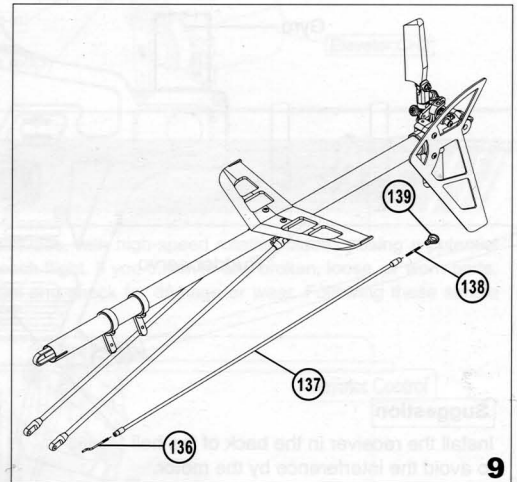

9

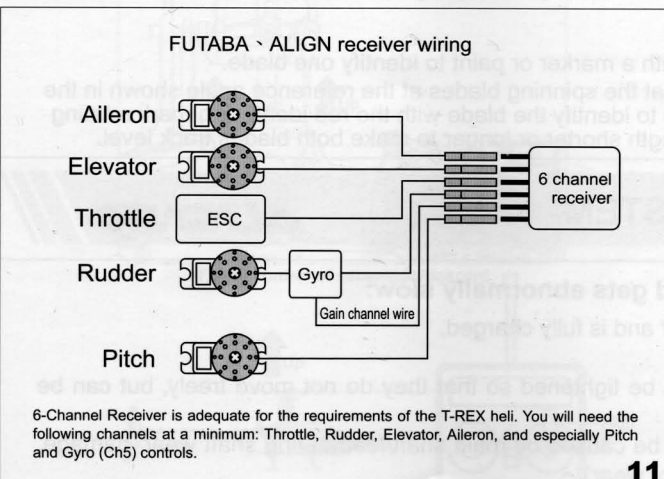
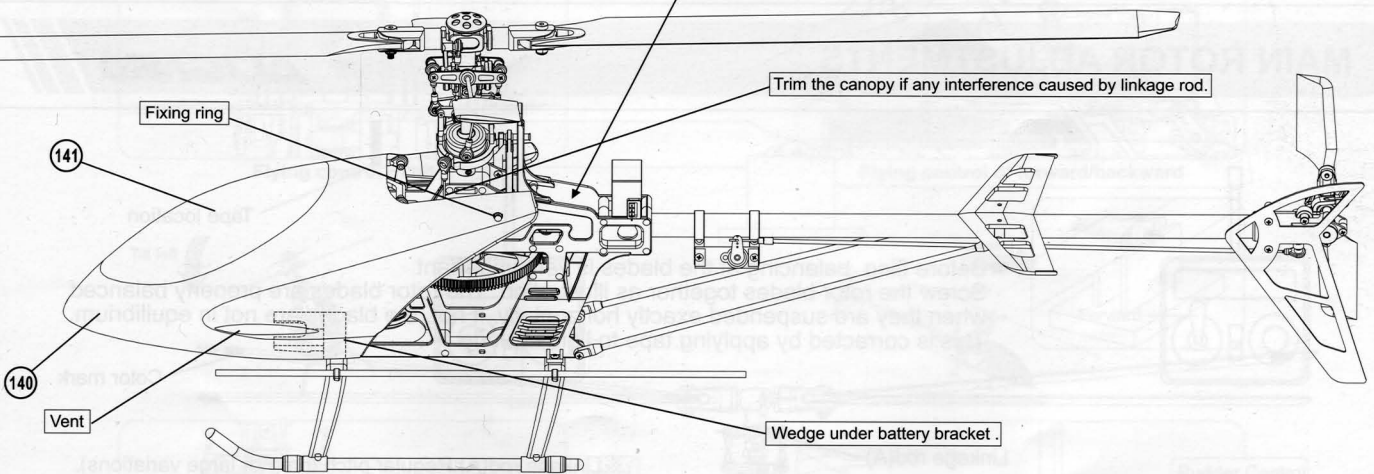

11

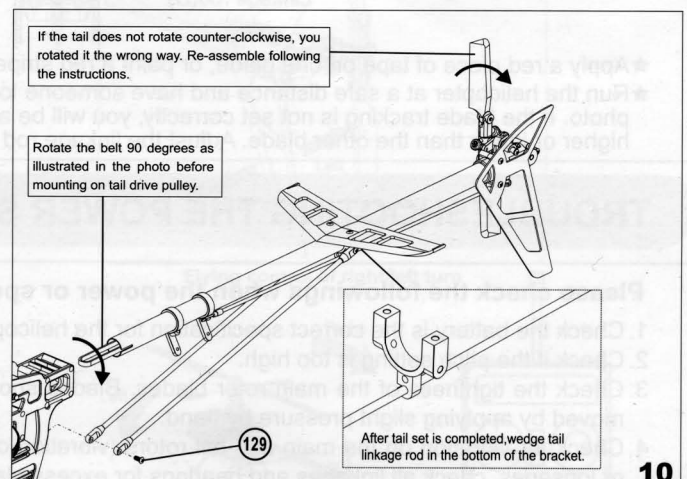

10

PARTS AND EQUIPMENT ASSEMBLY ILLUSTRATION

Illustration of Main Rotor's Pitch at 0 degree

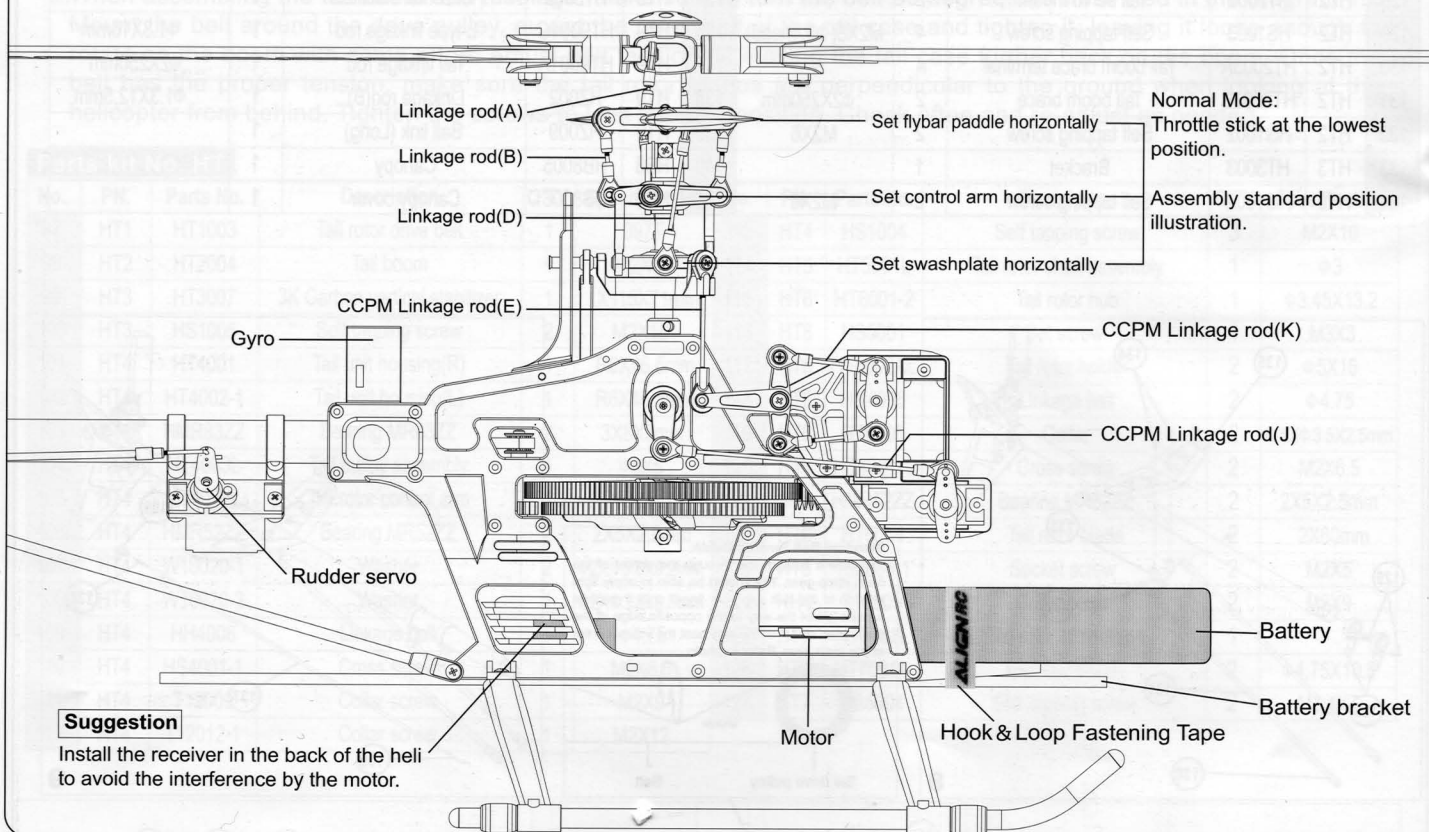

MAIN ROTOR ADJUSTMENTS

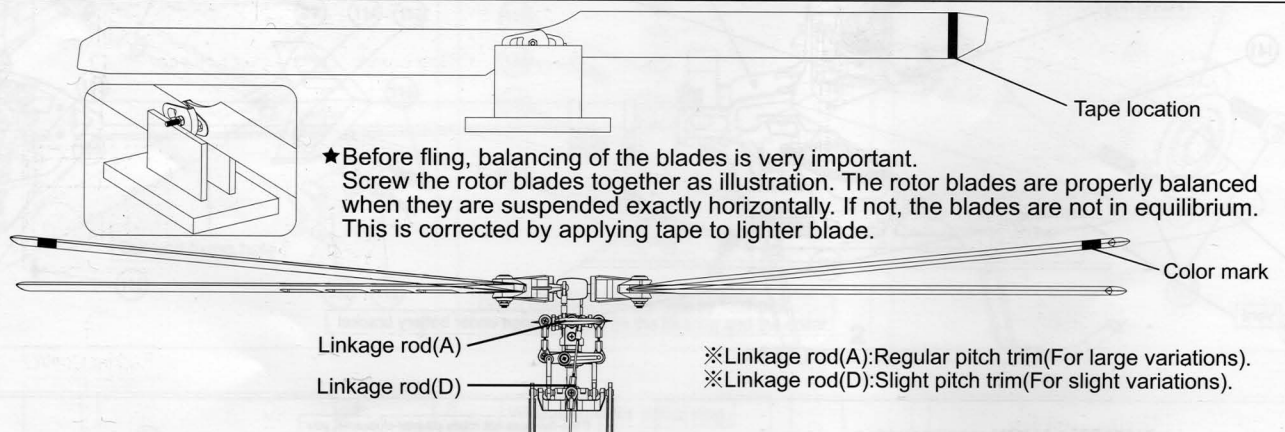

- ★ Apply a red piece of tape on one blade, or paint a red stripe with a marker or paint to identify one blade.
- ★ Run the helicopter at a safe distance and have someone look at the spinning blades at the reference angle shown in the photo. If the blade tracking is not set correctly, you will be able to identify the blade with the red identifying mark rotating higher or lower than the other blade. Adjust the linkage rod length shorter or longer to make both blades track level.

TROUBLESHOOTING THE POWER SYSTEM

Please check the followings when the power or speed gets abnormally slow:

1. Check the battery is the correct specification for the helicopter and is fully charged.
2. Check if the pitch setting is too high.
3. Check the tightness of the main rotor blades. Blades should be tightened so that they do not move freely, but can be moved by applying slight pressure by hand.
4. Check for vibration on the main and tail rotors (vibration can be caused by main shaft/feathering shaft wear, damage, or loosens, check all linkages and bearings for excess play or wear).
5. Check for interference caused by improper gear mesh or belt tension.

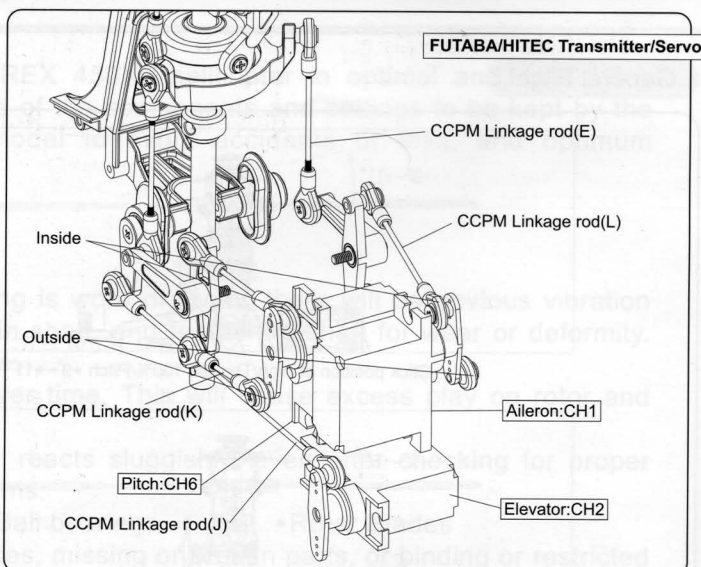
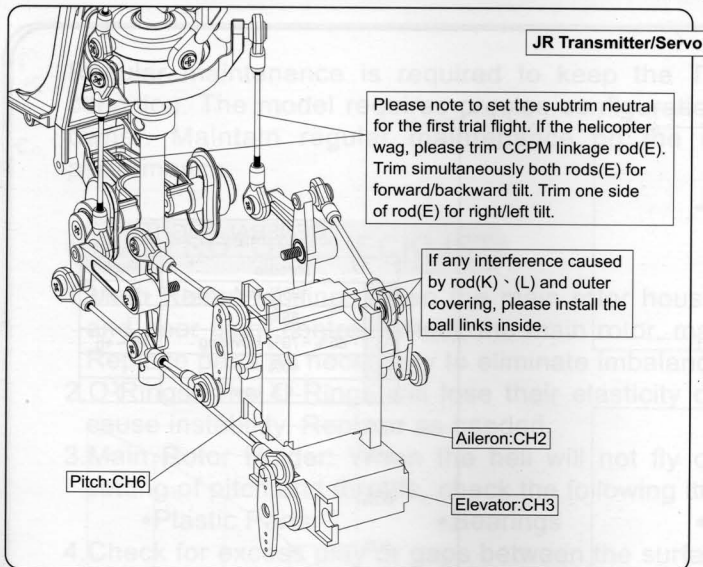

PRE-FLIGHT CHECKLIST("MODE 1" CONTROLS)

This model helicopter is an electronically controlled mechanical device traveling at high speeds and altitudes, with high-speed rotating blades posing a potential dangerous risk. Please make it a habit to always perform a pre-flight check of the entire model prior to each flight. If you discover any broken, loose, or worn parts, do not fly the model. Repair or replace items immediately. After each flight, completely clean the model and check for damage or wear. Following these simple steps will provide for maximum enjoyment owning and operating the T-REX Helicopter.

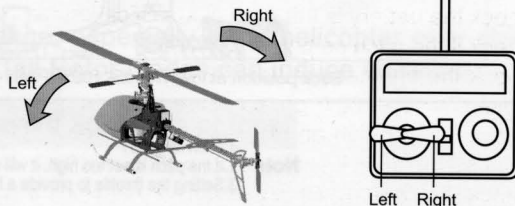
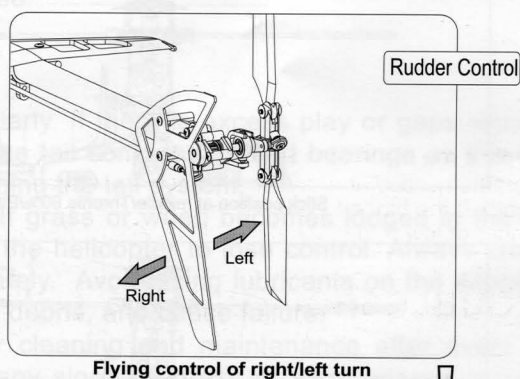
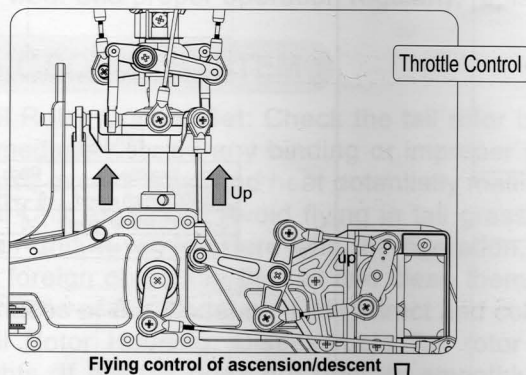
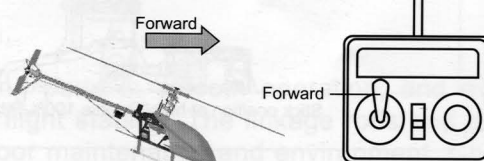
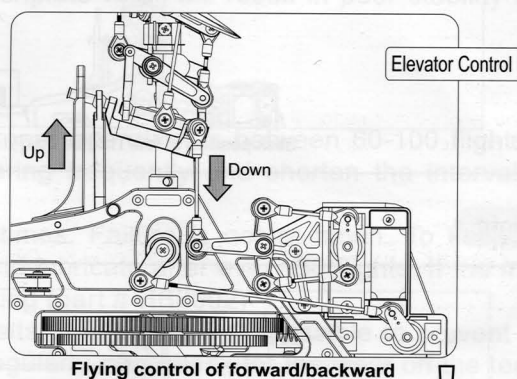
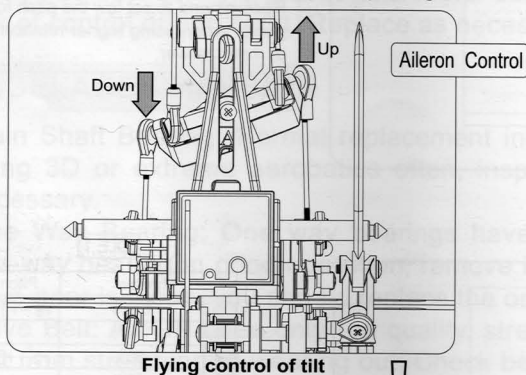

General Flight

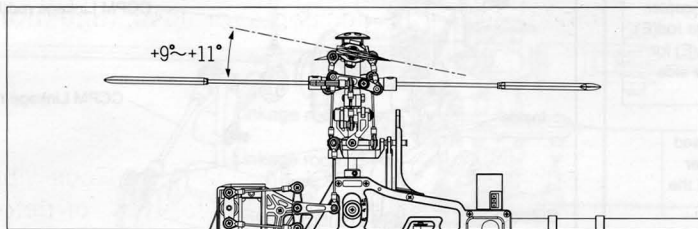

Stick position at high/Throttle 100%/Pitch $+9^{\circ}\sim+11^{\circ}$

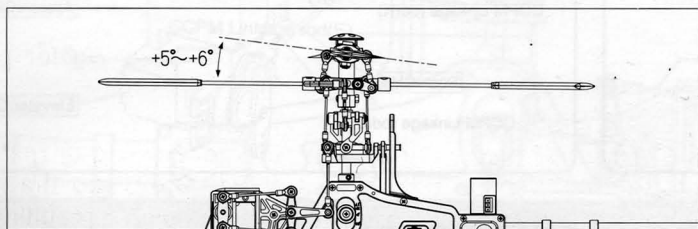

Stick position at Hovering/Throttle 65%~70%/Pitch $+5^{\circ}\sim+6^{\circ}$

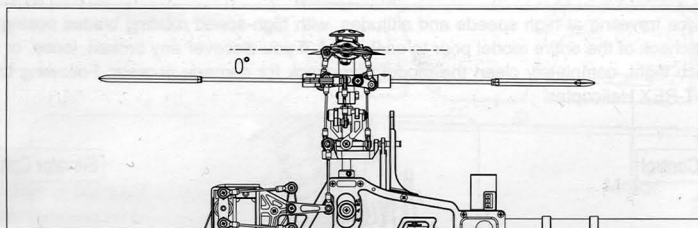

Stick position at low/Throttle 0%/Pitch 0°

GENERAL FLIGHT

	Throttle	Pitch
5	100% High speed	$+9^{\circ}\sim+11^{\circ}$
4	85%	
3	65%~70% Hovering	$+5^{\circ}\sim+6^{\circ}$
2	40%	
1	0% Low speed	0°

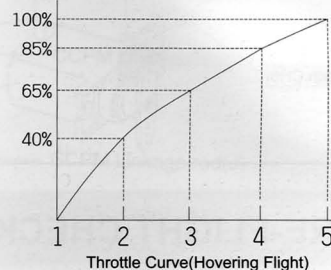

Pitch and Rotation Speed

Collocation tip:
Recommend to set low the pitch for better power when using higher rotation speed of motor power.

3D Flight

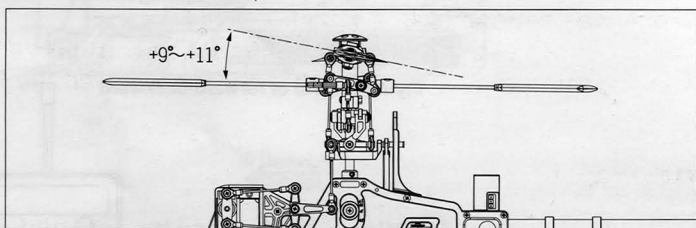

Stick position at high/Throttle 100%/Pitch $+9^{\circ}\sim+11^{\circ}$

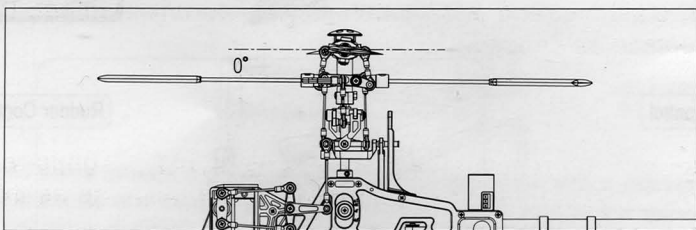

Stick position at middle/Throttle 90%/Pitch 0°

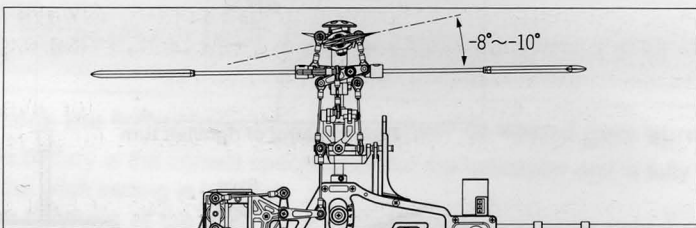

Stick position at low/Throttle 100%/Pitch $-8^{\circ}\sim-10^{\circ}$

IDLE 1

	Throttle	Pitch
5	100%	$+9^{\circ}\sim+11^{\circ}$
4	85%	
3	80%	$+5^{\circ}\sim+6^{\circ}$
2	85%	
1	90%	-5°

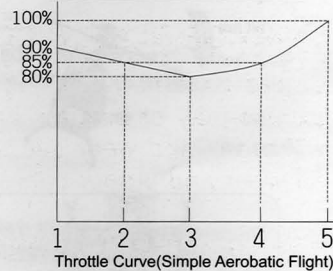

IDLE 2

	Throttle	Pitch
5	100% High speed	$+9^{\circ}\sim+11^{\circ}$
3	90% Middle speed	0°
1	100% Low speed	$-8^{\circ}\sim-10^{\circ}$

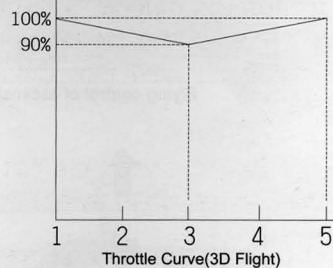

- Note**
1. Pitch range: 21°
 2. If the pitch is set too high, it will result in shorter flight duration and poor motor performance.
 3. Setting the throttle to provide a higher speed is preferable to increasing the pitch too high.

Regular maintenance is required to keep the T-REX 450XL helicopter in optimal and safe flying condition. The model requires precise configuration of the components and settings to be kept by the owner. Maintain regular maintenance on the model to avoid accidents or loss, and optimum performance.

MAIN ROTOR CHECKLIST

1. Main Rotor Housing: When the main rotor housing is worn or faulty, there will be obvious vibration and poor flight control. Check the main rotor, main shaft, and feathering shaft for wear or deformity. Replace parts as necessary to eliminate imbalance.
2. O-Rings: The O-Rings will lose their elasticity over time. This will cause excess play on rotor and cause instability. Replace as needed.
3. Main Rotor Holder: When the heli will not fly or reacts sluggishly, even after checking for proper setting of pitch and throttle, check the following items:
 - Plastic Parts
 - Bearings
 - Ball bearings
 - Rotor Blades
4. Check for excess play or gaps between the surfaces, missing or broken parts, or binding or restricted movement. It is important to check for main rotor balance before each flight. Operating the model when out of balance will cause excessive wear and premature failure of parts, possibly resulting in a dangerous situation.
5. Control Arm Assembly: Check regularly for cracked, worn, bent or binding control arms and pushrods. Smooth movement of control arms and linkages is required for stable, vibration free flight.
Swashplate: Check for excess slop in the main ball where the main shaft rides on, and slop or looseness between the plastic and metal surfaces. Swashplate wear will result in poor stability and lack of control during flight. Replace as necessary.

FUSELAGE/CHASSIS

1. Main Shaft Bearing: Normal replacement interval for proper operation is between 60-100 flights. If flying 3D or extreme aerobatics often, inspect the bearing frequently and shorten the interval as necessary.
2. One Way Bearing: One way bearings have longer lifetimes. Failure is not common. To keep the one-way bearing in good operation, remove it to clean and lubricate after every 50 flights. If the main drive gear is loose, you should replace the one-way bearing (part # HB6002)
3. Drive Belt: ALIGN uses only top quality, stretch-proof belts. It is however, impossible to prevent the belt from stretching or wearing out. Check belt tension regularly, and check for the wear on the teeth. Replace as necessary.

LINKAGE RODS & CONNECTING PARTS

During assembly, take special care to keep the connecting parts in smooth operation, and avoid excess play or binding. Failure to do so will result in poor flight stability. The linkage rods and ends will break and wear due to normal usage, crashing, and poor maintenance and environment. Check for wear and proper operation regularly, replace as needed.

TAIL ROTOR SYSTEM

1. Tail Rotor Control Set: Check the tail rotor bearing regularly. If there is excess play or gaps replace immediately. Avoid any binding or improper contact on the tail components and bearings as this will cause excess wear and heat potentially melting or deforming the tail system.
2. Tail Unit Assembly: Avoid flying in tall grass or weeds. If grass or weed becomes lodged in the tail rotor unit, it will interfere with the operation, and cause the helicopter to lose control. Always check for foreign objects in the tail and clean them off immediately. Avoid using lubricants on the exposed surfaces of the model as it will attract and collect dirt and debris, and cause failure.
3. Tail Rotor Housing: Disassemble Tail rotor housing for cleaning and maintenance after every 50 flights. If the tail does not operate smoothly or shows any signs of stress or wear, please replace immediately.
4. Tail Rotor: Check the Tail Rotor blades regularly for damage, especially if the helicopter ever strikes the ground while flying, or after hard landings. Damaged Tail Rotor blades can induce vibration.

NOTICE: Maintain regular maintenance on the model to avoid accidents or loss.

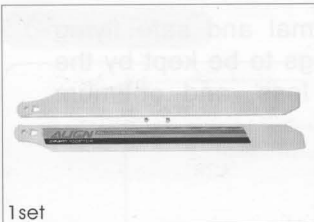

1set
HS1097
325 Fiber rotor blade(yellow)

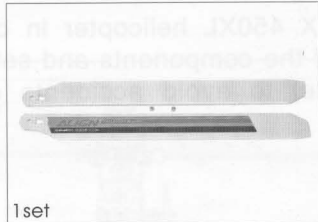

1set
HS1094
325 Fiber rotor blade(white)

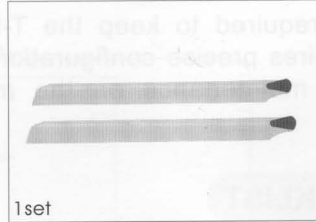

1set
HS1052
315 Wooden rotor blade

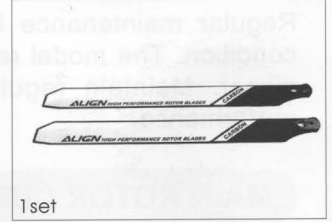

1set
HS1042
325 Carbon rotor blade

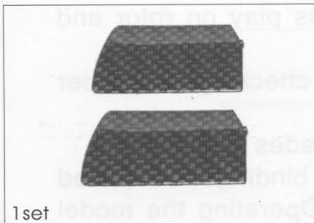

1set
HS1046
3K Flybar paddle

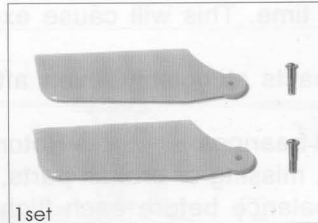

1set
HS1096
Tail rotor blade(yellow)

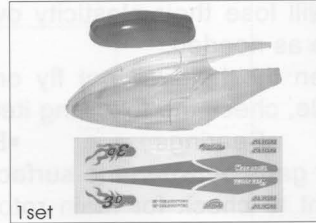

1set
HS1068
XL Canopy set(pellucid)

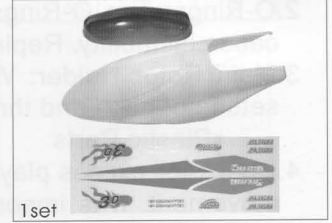

1set
HS1069
XL Canopy set(white)

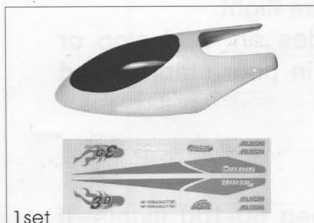

1set
HS1088
XL Fiber glass canopy set

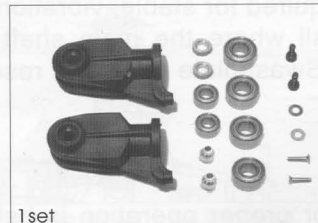

1set
HS1070
Main rotor holder set(XL)

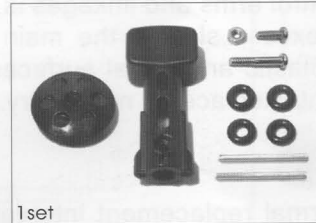

1set
HS1071
Main rotor housing(XL)

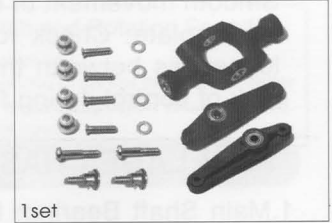

1set
HS1072
SF mixing lever set(XL)

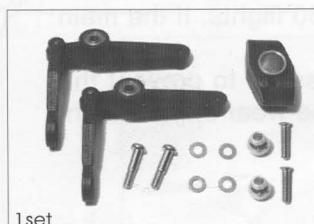

1set
HS1073
Flybar control lever set(XL)

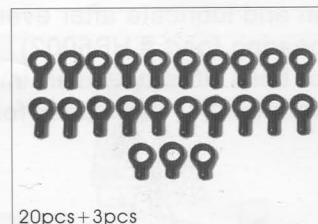

20pcs+3pcs
HS1074
Ball link

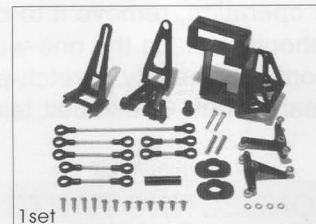

1set
HS1093
CCPM Riffitting components

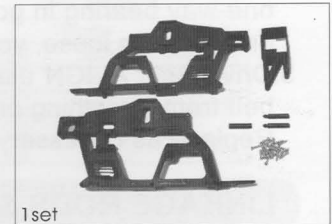

1set
HS1076
Main frame set(XL)

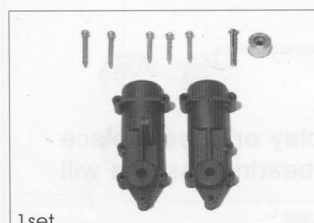

1set
HS1077
Tail case(XL)



1set
HS1078
Tail rotor control assembly(XL)

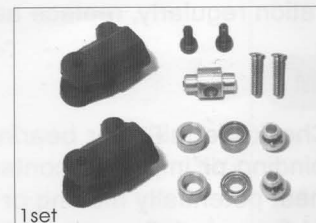

1set
HS1079
Tail holder set(XL)

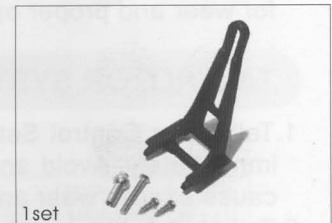

1set
HS1082
Anti rotation bracket

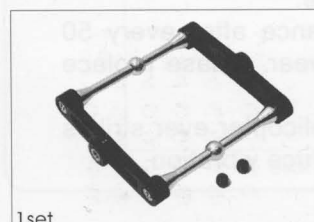

1set
HS1086
Flybar control set

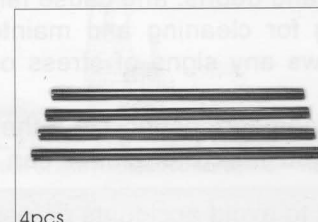

4pcs
HS1003
Feathering shaft



1set
HS1090
CCPM Swashplate(XL)

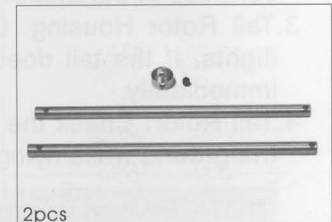

2pcs
HS1011-2
Main shaft

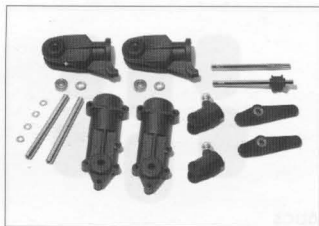

HP2014
Outdoor first-aid parts(XL)

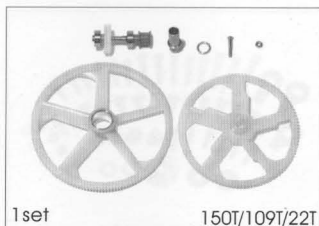

1set
HP2013
Main drive gear(XL)

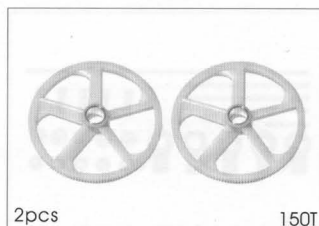

2pcs
HS1057
Main drive gear(XL)

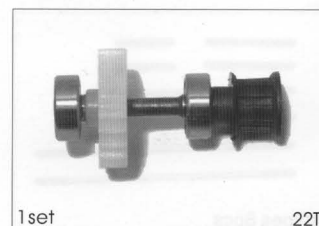

1set
HS1013-1
Tail drive gear assembly

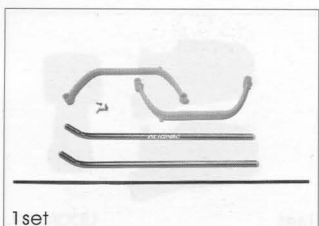

1set
HS1098
Landing skid set(yellow)

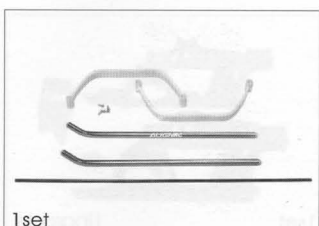

1set
HS1014-1
Landing skid set(white)

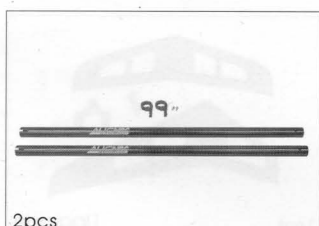

2pcs
HZ030
Tail boom(XL)

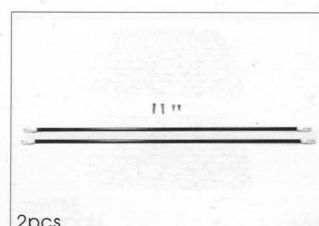

2pcs
HS1016
Tail boom brace

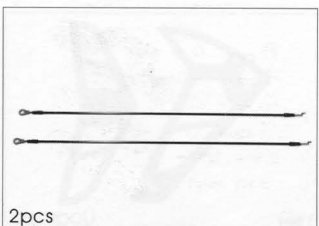

2pcs
HS1017
Tail linkage rod

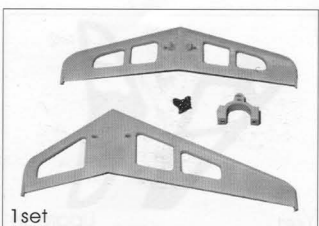

1set
HS1018
Vertical / horizontal stabilizer

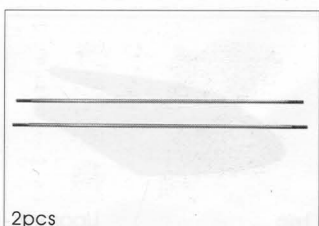

2pcs
HS1006
Flybar rod

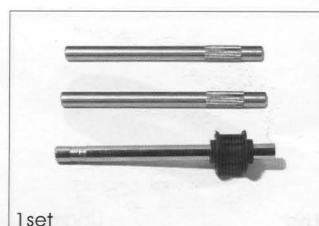

1set
HS1021-1
Tail rotor shaft

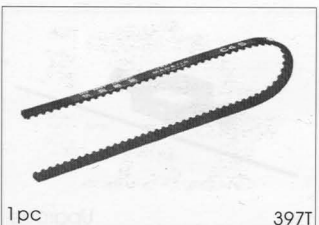

1pc
HS1003
Drive belt(XL)

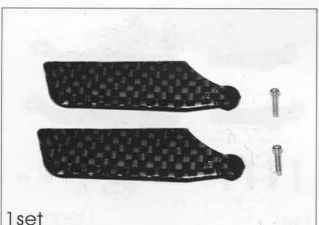

1set
HS1047
3K Tail rotor blade



1pc
HS1036
Main rotor fixing



1pc
HS1026
One way bearing

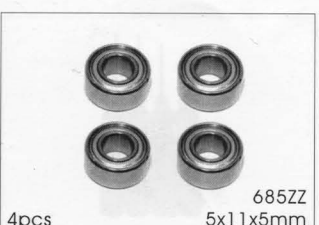

4pcs
HS1028
Bearings

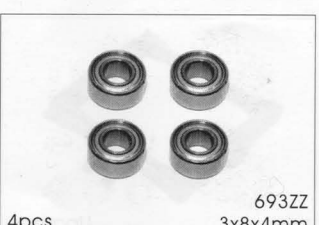

4pcs
HS1029
Bearings

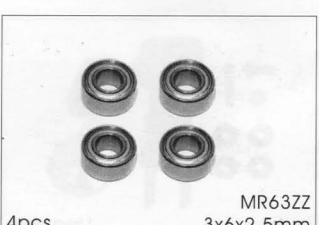

4pcs
HS1030
Bearings

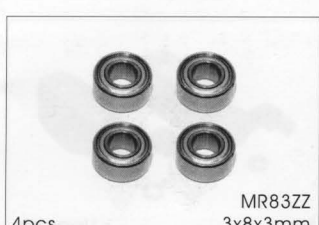

4pcs
HS1031
Bearings



4pcs
HS1032
Bearings

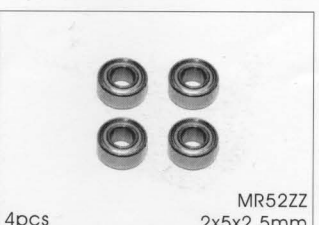

4pcs
HS1033
Bearings



4pcs
HS1058
Bearings



12pcs + 24pcs
HS1027
Linkage ball

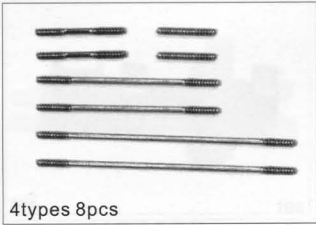

4types 8pcs

HS1034
Linkage rod

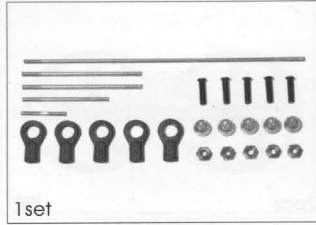

1set

HS1035
Servo linkage rod

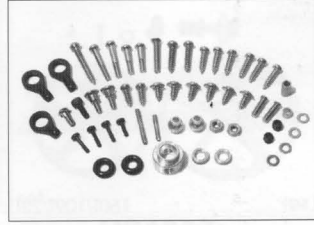

HZ027
Hardware bag

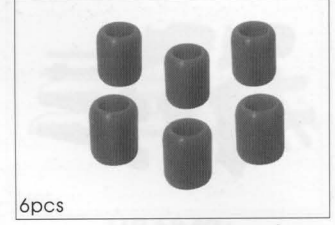

6pcs

HZ022
Landing skid nut



1pc

347mm
Upgrade

HZ018
3K Carbon tail boom(XL)

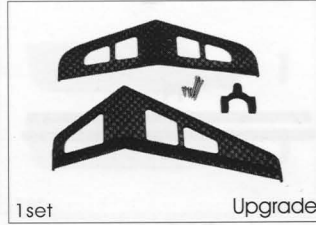

1set

Upgrade

HS1043
3K Vertical / horizontal stabilizer

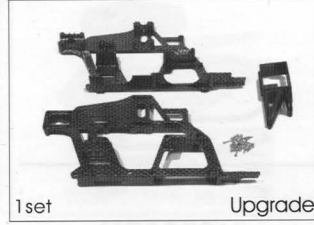

1set

Upgrade

HS1044
3K Main frame set

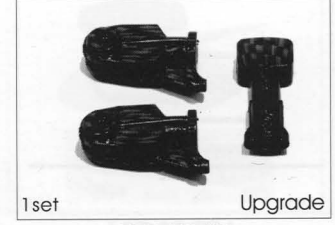

1set

Upgrade

HS1048
3K Main rotor case



1pc

Upgrade

HS1083
3K Canopy cover

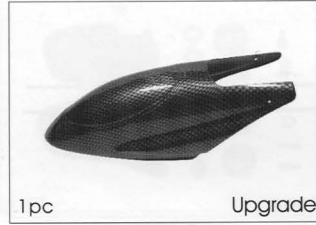

1pc

Upgrade

HS1084
3K Canopy

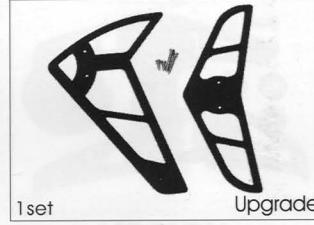

1set

Upgrade

HS1055
3K Carbon Vertical / horizontal stabilizer

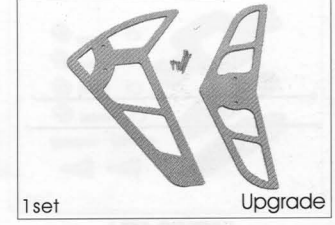

1set

Upgrade

HS1064
3K Carbon Vertical / horizontal stabilizer(Sliver)

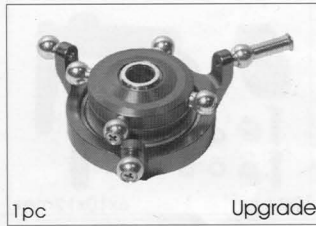

1pc

Upgrade

HS1089
CCPM Aluminum swashplate(XL)

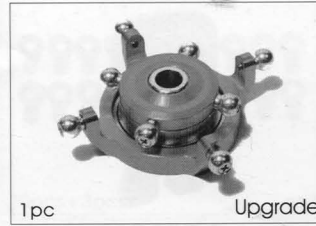

1pc

Upgrade

HS1062
Aluminum swashplate(V2)

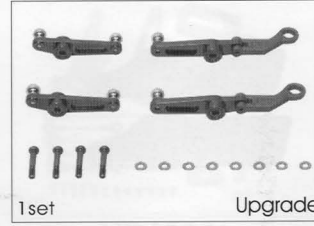

1set

Upgrade

HS1056
Metal control lever

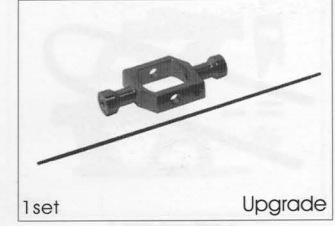

1set

Upgrade

HS1060
Metal flybar seesaw holder



1set

Upgrade

HS1065
Metal main rotor holder

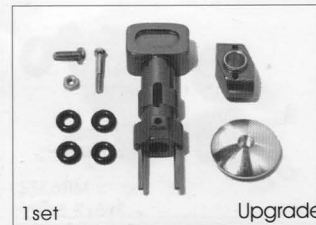

1set

Upgrade

HS1080
Metal main rotor housing

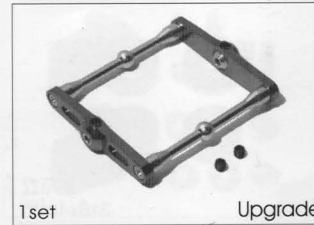

1set

Upgrade

HS1081
Metal flybar control set

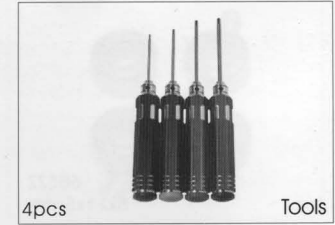

4pcs

Tools

HZ024
Hexagon screw driver

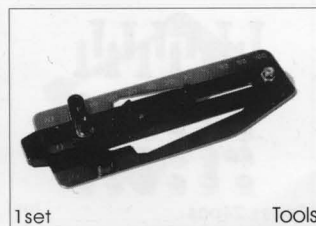

1set

Tools

K10180A
Micro heli pitch gauge

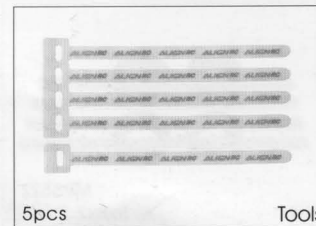

5pcs

Tools

HS1066
Hook & loop fastening tape(5pcs)

Specifications & Equipment:

Length: 650mm
Height: 230mm
Main Rotor Diameter: 680/700mm
Tail Rotor Diameter: 150mm
Motor Drive Gear: 15T/13T/11T
Main Drive Gear: 150T
Autorotation Tail Drive Gear: 109T
Tail Drive Gear: 22T
Drive Gear Ratio: 1:10:4.95/1:11.5:4.95/1:13.6:4.95
Weight(w/o Power System): 330 / 355g
Weight(w/ Power System): 620~670g

Recommended Power and Radio Equipment (Not included in kit):

Lithium Battery: DC11.1V(1300mAh or more)
400 Brushless Motor: 2500-3800KV
ESC: 25-35A
Transmitter: 6 channel or more(Helicopter System)
Receiver: 6 channel or more
Gyro: 1pc
Servo: 9g x3pcs
Rud servo: 6g x1pc

www.align.com.tw