

KAVAN alouette 2

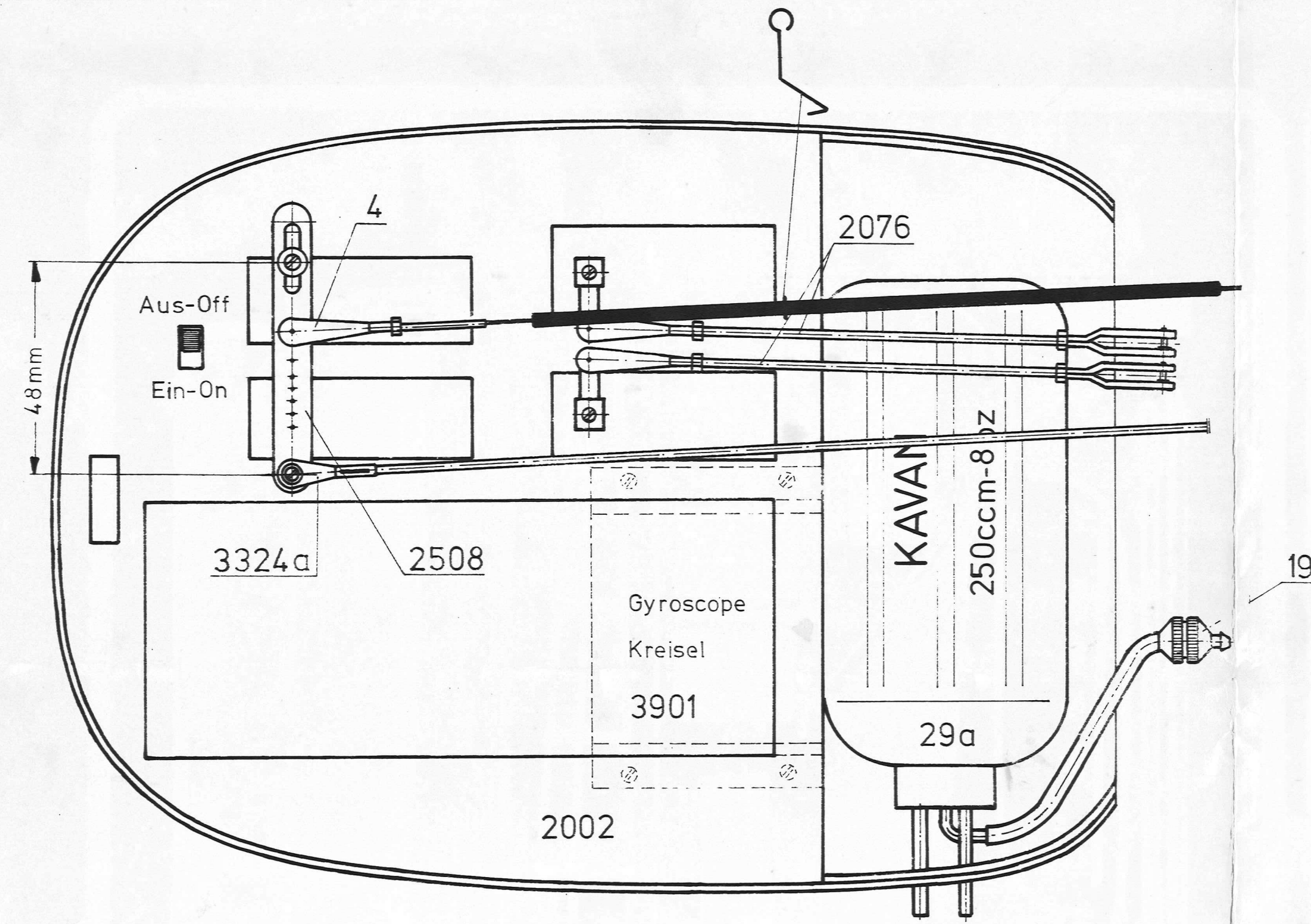

Technische Daten: ges.gesch.	Technical Particulars: pat.reg.
Hauptrotordurchmesser: 1080mm	Main rotor diameter: 1080mm (42")
Rumpflänge: 1000mm	Fuselage length: 1000mm (40")
Scale: 1:10	Scale: 1:10
Motor: 40 ccm	Engine: 40 cu in
Steuerung: 4Kanal-Prop.	Controls: 4 channel-prop.
Fluggewicht: 3 kg.	Flight weight: 6 lbs.
Zuladung: 50%	Payload: 50%

Made in W. Germany
1976

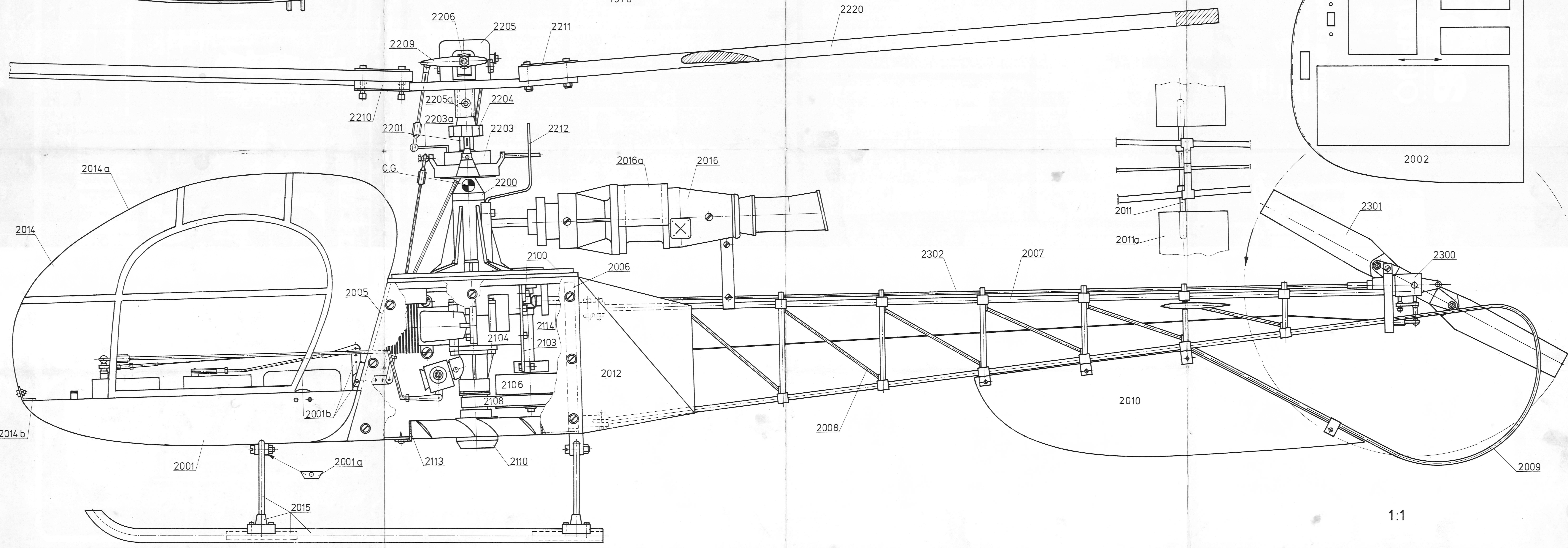
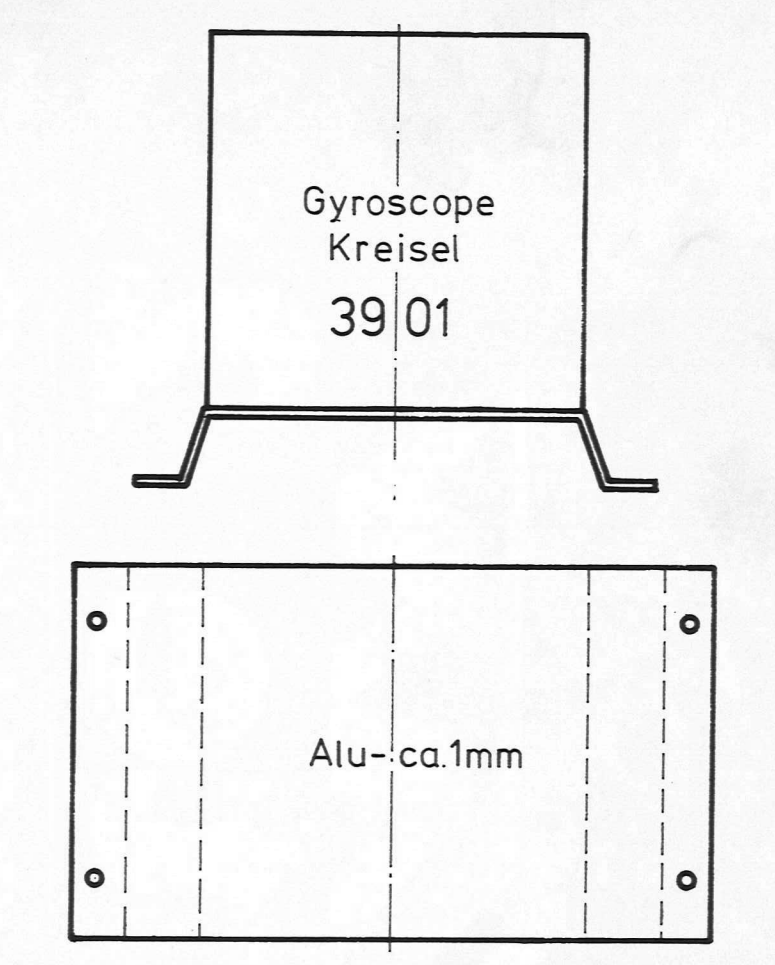
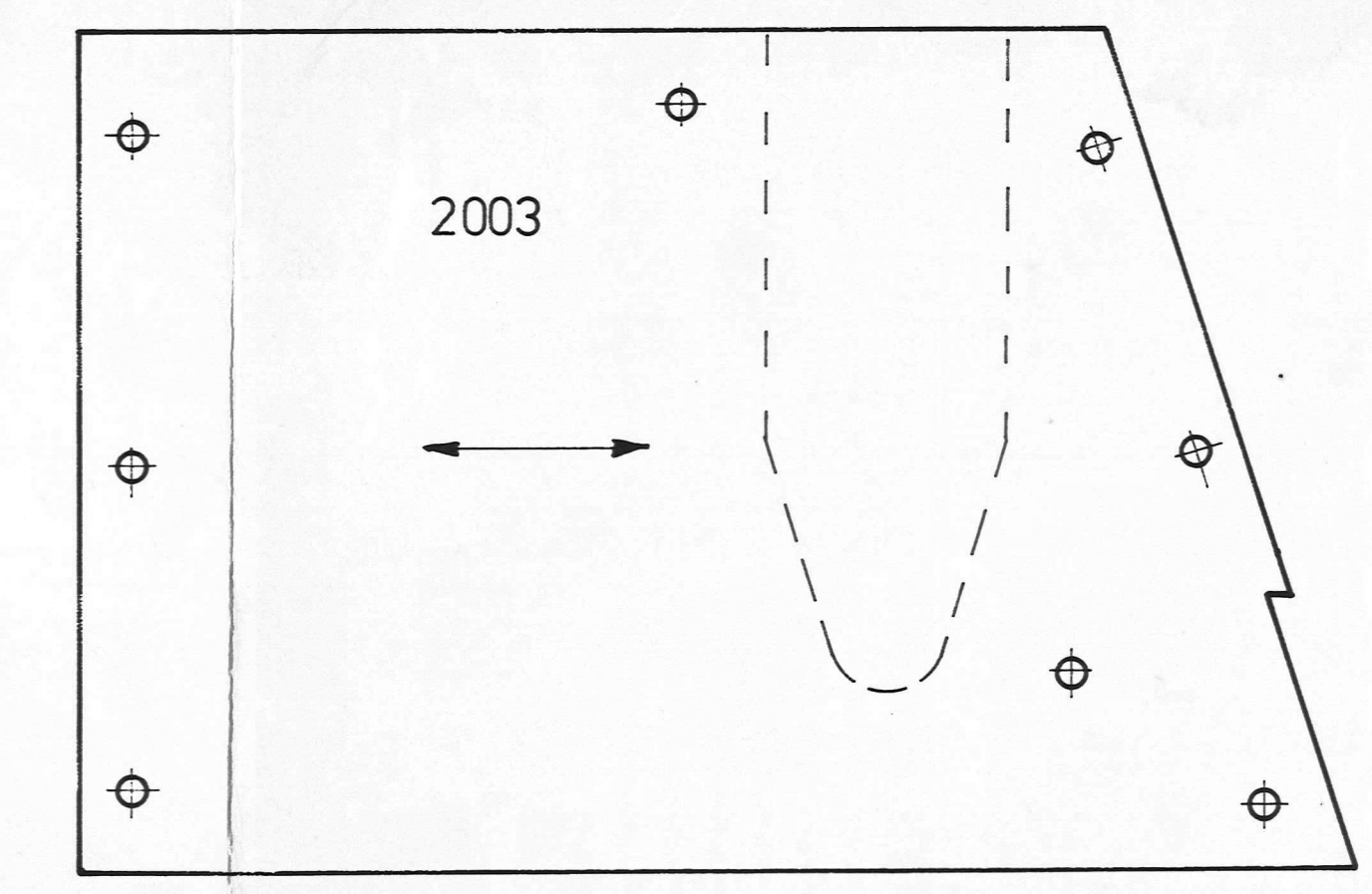
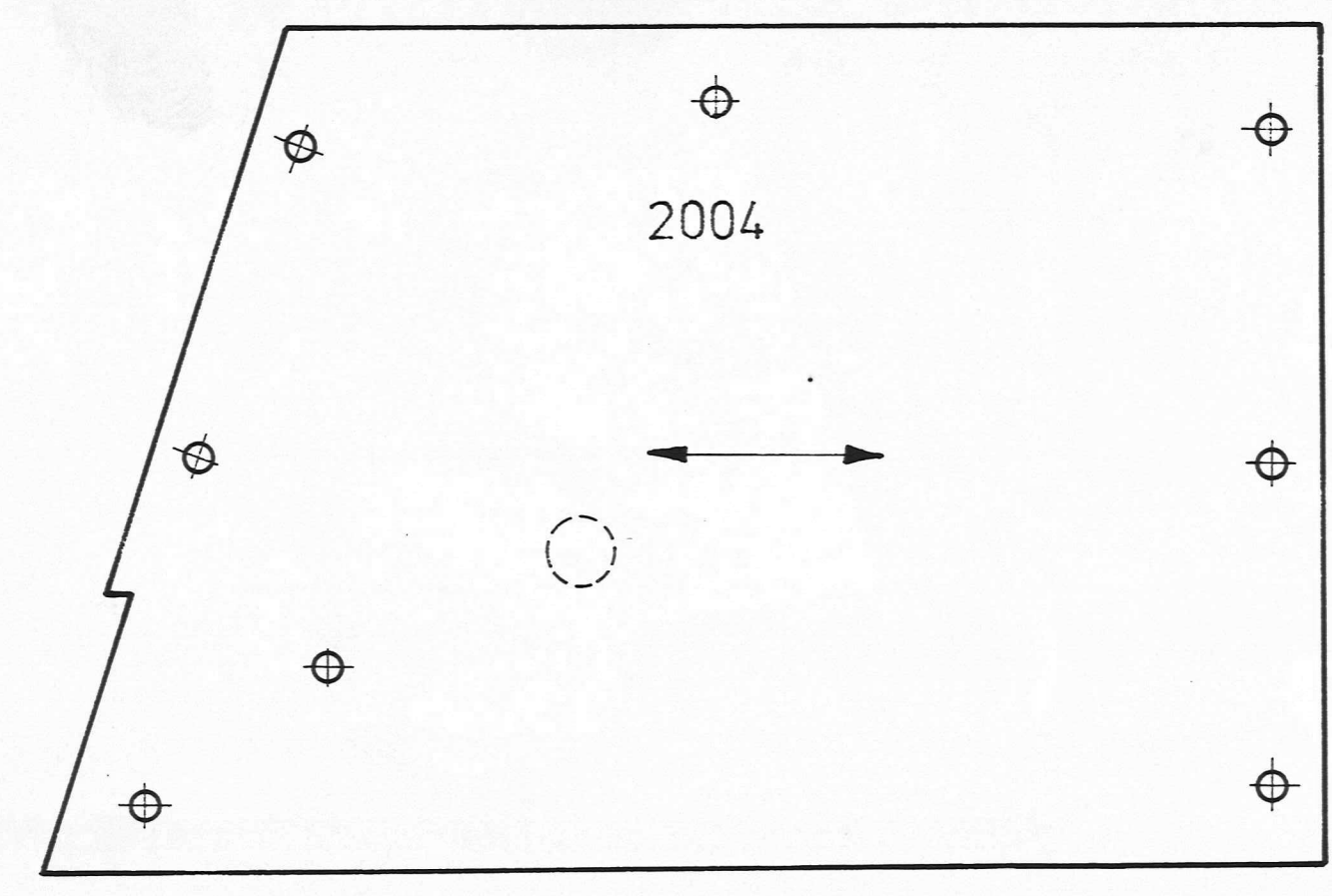

1:1