

INFUSION 700E Platinum

***** Instruction Manual



Nigel Brown
DESIGNED BY
NIGEL BROWN



ENDLESS PURSUIT OF PERFECTION

Welcome to the TSA family and congratulations on your new purchase. Please read this instruction manual carefully to ensure you understand every step of the build process. Most of all happy building and we look forward to seeing you around the world at many events.

Contents

- ★ 1~2. Introduction
- ★ 3. Safety instructions prior to assembly
- ★ 4. Tools required for assembly
- ★ 5~26. Parts assembly
- ★ 27. Blade tracking adjustment
- ★ 28~29. Operation mode
- ★ 30. Flying notes
- ★ 31~36. Parts package list



***** **INFUSION 700E**
Platinum



While in flight

- 1: Beginners should obtain safety and technical guidance from an experienced individual, since learning alone to operate this machine is potentially dangerous.
- 2: Choose a safe flying area that is free of obstruction and people.
- 3: Do not fly in a potentially dangerous environment.
- 4: Do not operate while standing on tilted ground to avoid loss of balance.
- 5: Do not operate in an awkward body posture. Do not insert hands and objects in rotating parts.
- 6: Keep a safe distance from the unit and be sure to operate the unit within the limits of your ability. Failure to operate this unit properly may result in serious harm such as physical injury, damages to property, and even death.
- 7: Enjoy flying while observing safety rules and regulations. Fatigue brought upon by continuous operation may result in impaired judgment that may lead to accidents.
- 8: Inquiries regarding repairs and services should only be made to TSA authorized dealers or TSA technical support department. Individual lacking proper training or knowledge necessary for repair may not only impair the unit's performance, but also increases the risk of accidents or injury. The engine must be turned off before performing any repairs or adjustments. Repair damaged parts before storage using only TSA manufactured parts. When storing or transporting the units, secure the unit carefully to avoid fuel loss, damage, or injury.



Using battery matters

- 1: New battery must be charged before use.
- 2: Battery should not be overcharged . If the battery is heat, stop charging, and take it out immediately..
- 3: The charge voltage for one cell should not be over 4.20V, and the all 6S battery should not be over 25.2V. Please use reliable and precision charger.
- 4: It's better not to use the battery over 70% of its voltage, or better to stop flying when the battery is less than 21.6V. This is to keep the performance of the battery, ensure the capacity and charge-discharge cycles.
- 5: It's battery to keep 3.6V to 3.9V voltage in the battery when store for a long time.
- 6: For 3D flying, the flying time should not be over 5 minutes.
- 7: If you are not confidence in charge, please contact with the local distributor.



Pre-flight inspection

- 1: Check that tools used for assembly and maintenance has been put away.
- 2: Check that there are no loose screws and parts.
- 3: Check that the rotor blades are not damaged or cracked, especially in the vicinity of the blade holder.
- 4: Check that electronic equipment and servos operates smoothly.
- 5: Check that the position of the transmitter's throttle stick and engine carburetor are at their lowest positions.
- 6: Check that the receiver receives signals properly.
- 7: Check and ensure that all necessary parts are sufficiently lubricated.
- 8: Do not use it in other electric equipments and magnetism place, or they will influence each other.



In-flight safety inspection

- 1: When starting the engine, be sure to hold the rotor head firmly so the rotor head does not rotate.
- 2: When taking off, the unit should be positioned at least 15 meters away from the operator. Be sure to check for people and dangerous object in the surrounding area before takeoff.
- 3: Adjust the tracking right before takeoff. Do not come near more than 5 meters when doing so.
- 4: Land the unit immediately if abnormal noise or vibration is observed. Then stop the engine and perform complete check for cause of problem.
- 5: Be responsible when operating this unit, as reckless or improper behavior may cause accidents or injury to self or others. Observe all safety rules and regulation while enjoy operating this unit safely and responsibly.



After-flight safety inspection

- 1: Immediately inspect parts after every flight. Be sure to replace, retighten any missing or loose screws and replace any damaged parts.
- 2: Wipe down grease, oil, dirt and dust with a clean cloth.
- 3: If not fly in long time, please take out the connector between the end of battery and the end of motor.
- 4: Store the unit in an area free of direct sunlight, or other areas that may result in rise in temperature (e.g., car). Instead, store in a shaded and ventilated area, and keep out of reach of children.



Warning

- 1: To reduce the risk of accidents and injuries, do not use parts other than those found in this manual or TSA catalog. TSA will not be responsible for problems caused by using non-genuine TSA parts.
- 2: If the rotor blades should strike the ground during flight, there may be tiny cracks or loosening in various places even though damages may not be clearly visible to naked eyes. If damage to the rotor blade is not fixed before flight, cracks and loosening may increase during flight that would lead to severe consequences. The rotor head may disassemble from the blade holder, which spins at a speed of 1200/2000 rpm, and may fly off from the blade holder. If in doubt regarding the condition of any part, replace the part immediately using only genuine TSA parts.
- 3: TSA will not be held responsible for damages or crash as a result from any loose screws and/or improper maintenance.
- 4: Radio wave transmitting distance is approximately one kilometer or more, therefore operator must check no other operators in the surrounding vicinity are using the same radio frequency.
- 5: This remote control model is not a toy, rather a precise machine. Proper assembly and adjustments must be made in order to avoid the risk of injuries or accidents. Operator should operate this unit safely and properly. Failure to operate this unit properly may result in serious harm such as physical injury, damages to properties, and even death. The operator is responsible for all damages, because TSA cannot control how the unit was assembled and used.
- 6: Recommended 14+ years .



Caution

Please abide by regulations in your country while enjoying the pleasure brought to you by the  700E series.



Preassembly precautions

1. Before assembly, read the instruction manual thoroughly and familiarize yourself with the unit's structure and assembly procedures. Failure to assemble the unit properly may not only impair performance but also increases the risk of danger.
2. Before assembly, check description and quantity of parts. In the event of missing or defective items, contact retailer of original purchase where authorized distributor or TSA support department can be located.

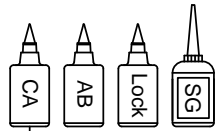

Self-furnished

CA=Cynoacrylate adhesive
 AB=5 minute epoxy / A=3 : B=1
 Lock=Thread lock
 SG=Silicone grease

Diagram for applying thread lock

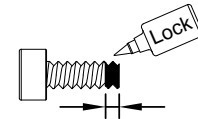

Glue width :1.5mm

3. Apply lubricant and retainers on locations as indicated .
4. In the instruction manual, refer to the left hand column to check the type and quantity of parts.

Swashplate Assembly

T-016-07

Parts order number

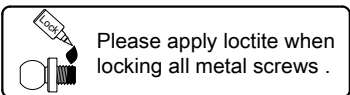

Part name and quantity in this diagram is to 1:1 ratio

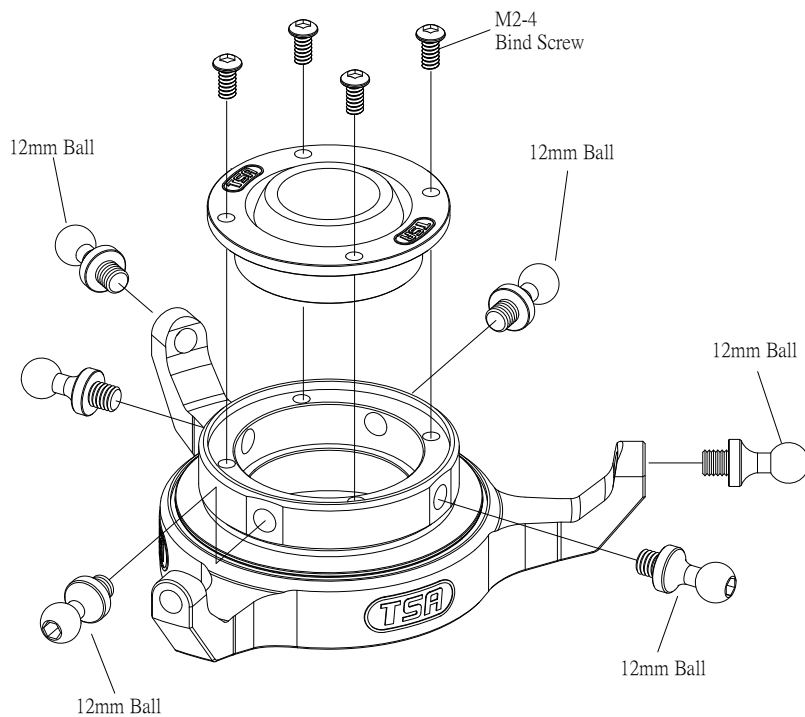
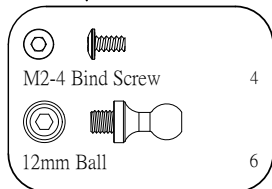

Assembly Tip

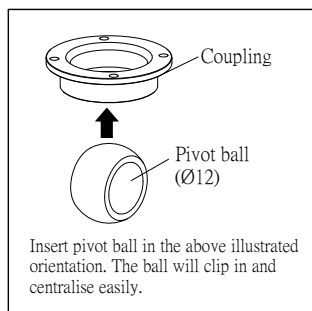

TOOLS REQUIRED FOR ASSEMBLY

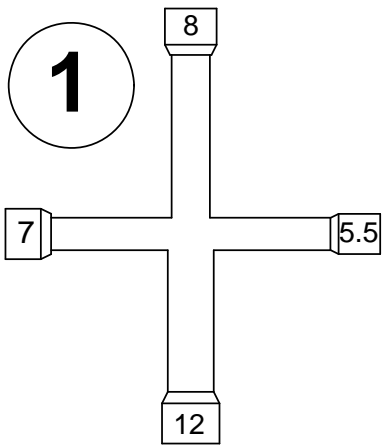

Cross wrench
(5.5~12)



Metric ruler
(Over 30cm)

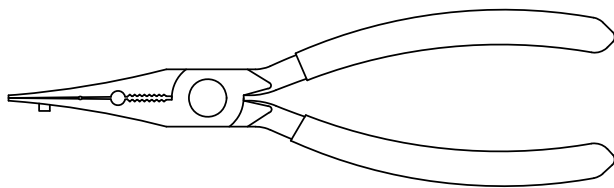

Universal ball link plier

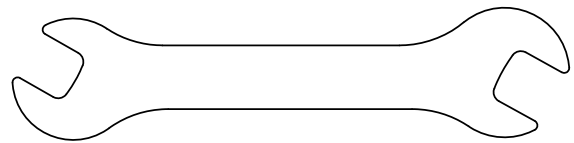

Spanner
(6mm/8mm/12mm/21mm)

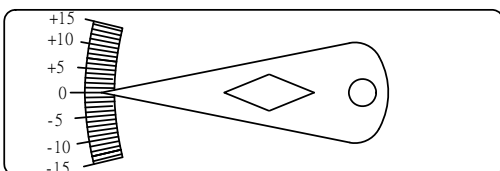

Pitch gauge

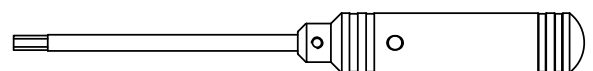

(Allen head) Screw drivers
(1.5mm/2mm/2.5mm/3mm/3.5mm/
4mm/5mm)

Equipment required for assembly

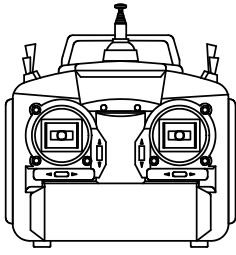

Transmitter(7 channels)

Receiver

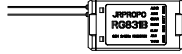

Receiver battery

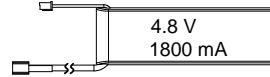

3 Axis gyro system

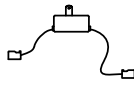

On/off switch

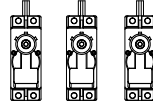

Servos



Rudder servo

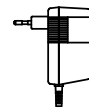

Charger

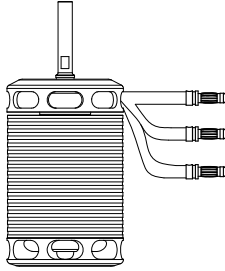

4500~11000W /
500~550KV
Brushless motor x1

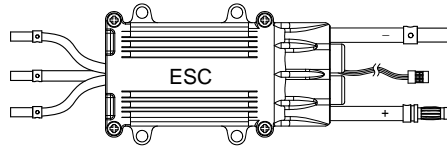

SBH-120A Brushless ESC x1

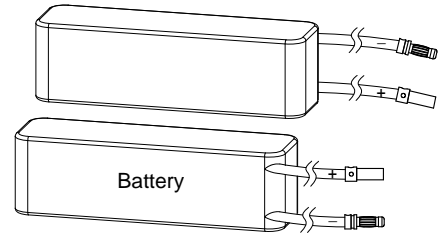

6S LiPo 4000~5000mAh x2

1

Main Frame Assembly-1

T-001-21

T-005-01

T-007-05

 Please apply loctite when locking all metal screws .

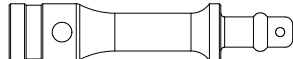

37.5mm Canopy rear support 1

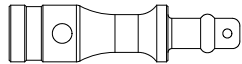

30.5mm Canopy front support 1



M3-6 Bind screw 3



M3-6 Cap screw 2



M3-8 Cap screw 2



Custom Washer 2



Ø5xØ10x4 Flange Brg 1

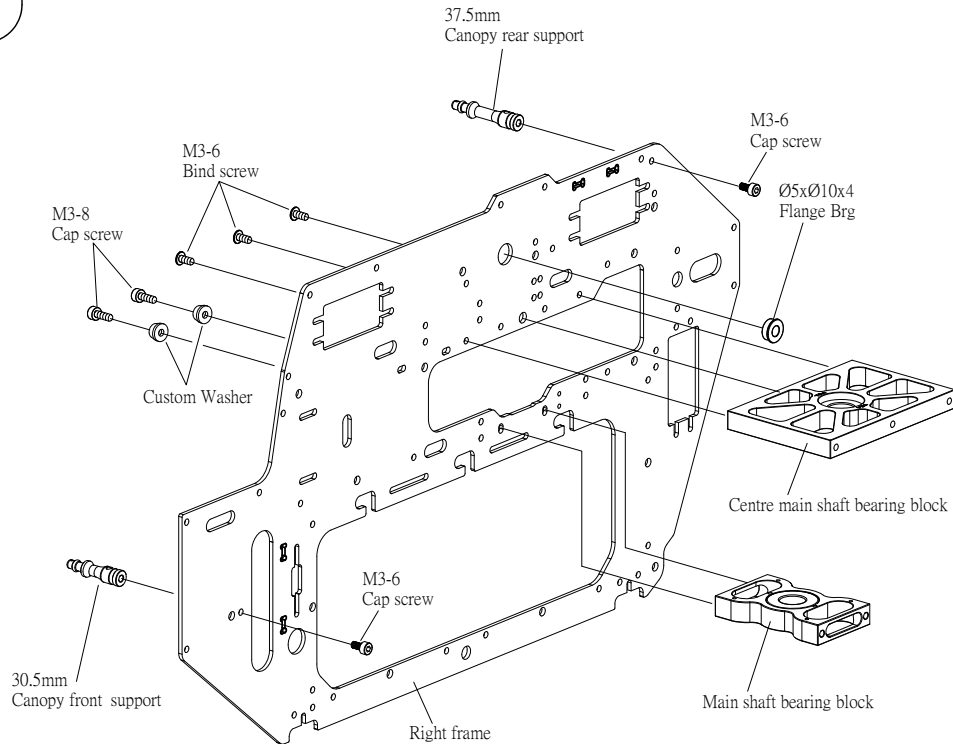

2

Main Frame Assembly-2

T-002-07

T-022-02

T-005-01

T-009-02

 Please apply loctite when locking all metal screws .

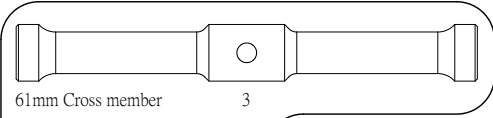

61mm Cross member

3

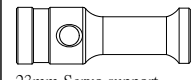

23mm Servo support

2

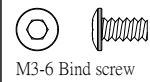

M3-6 Bind screw

2

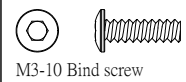

M3-10 Bind screw

1



M3-8 PH screw

10



M3-6 Cap screw

2

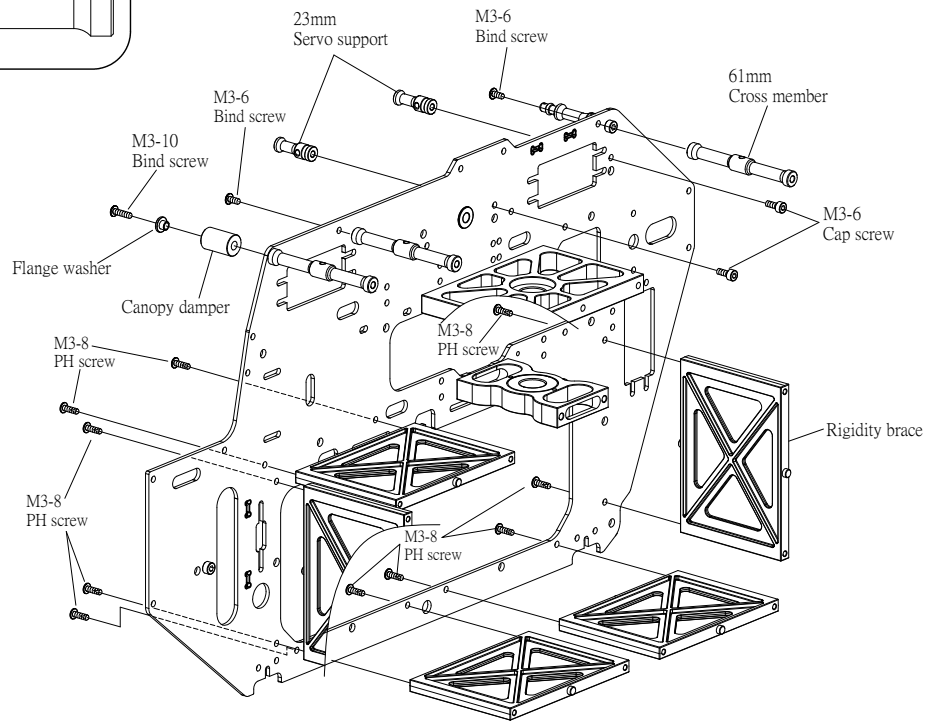

3

Tail Drive Gear Assembly

T-019-00

 Please apply loctite when locking all metal screws .

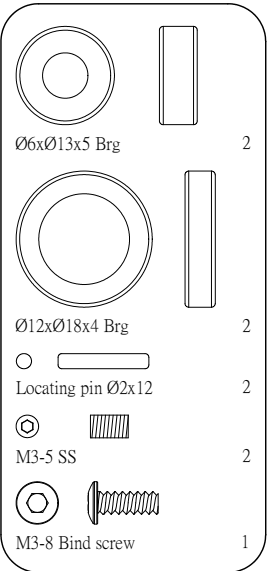

Ø6xØ13x5 Brg

2

Ø12xØ18x4 Brg

2

Locating pin Ø2x12

2

M3-5 SS

2

M3-8 Bind screw

1

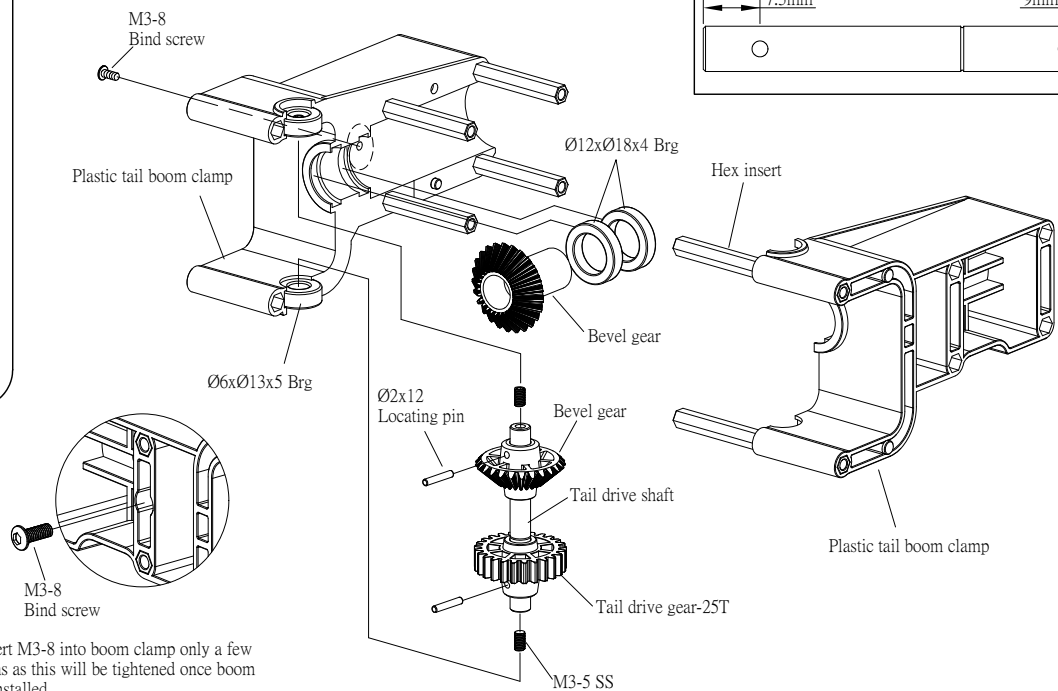

Insert M3-8 into boom clamp only a few turns as this will be tightened once boom is installed.

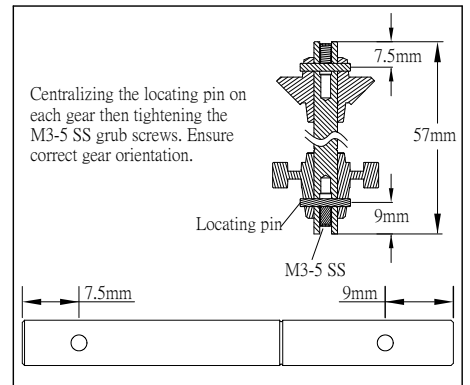

Centralizing the locating pin on each gear then tightening the M3-5 SS grub screws. Ensure correct gear orientation.

Locating pin

M3-5 SS

6

Landing Gear Assembly-1

T-012-00

T-013-01

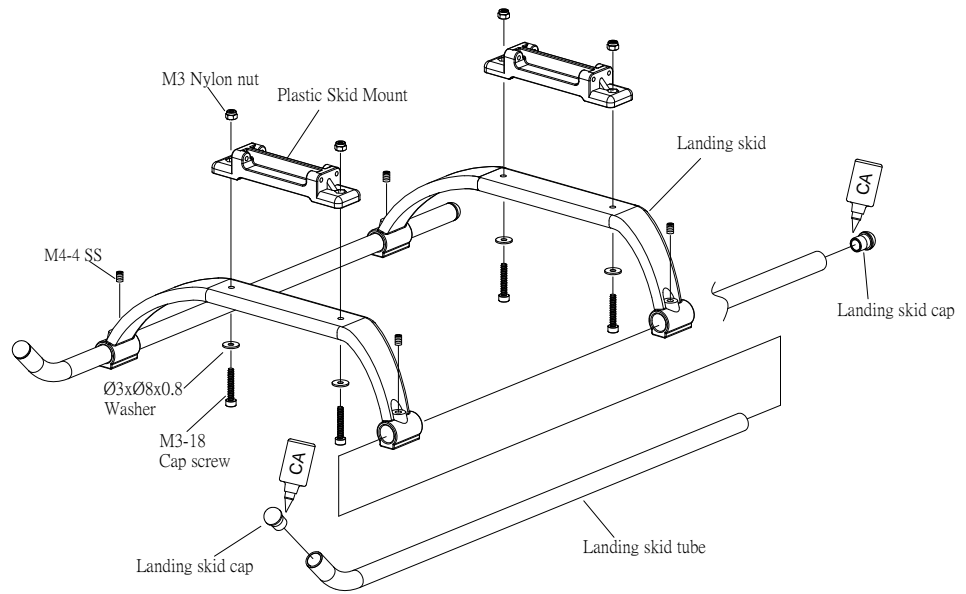
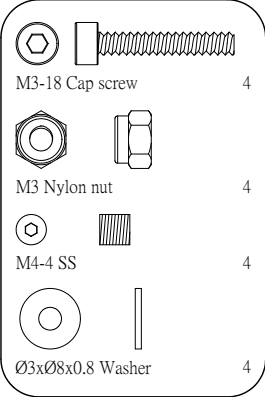

7

Landing Gear Assembly-1

T-002-07

T-012-00

T-007-05

T-030-04

T-008-01

T-030-06

Please apply loctite when locking all metal screws .

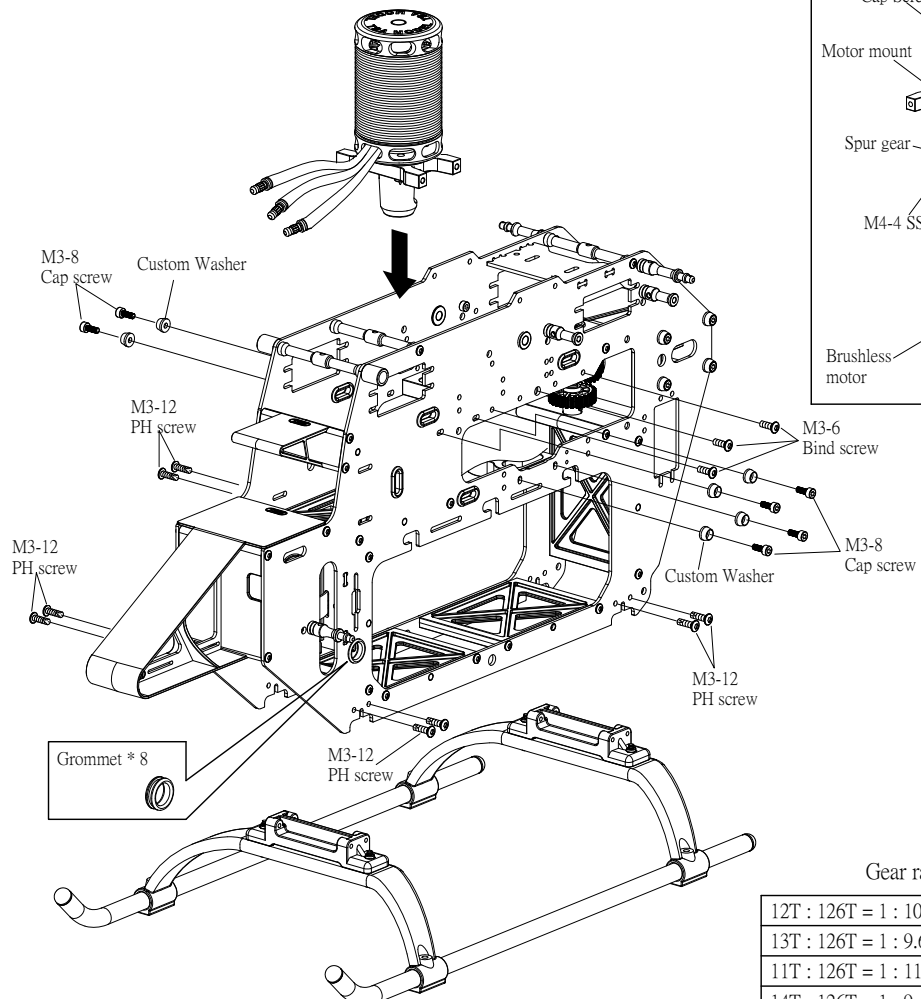
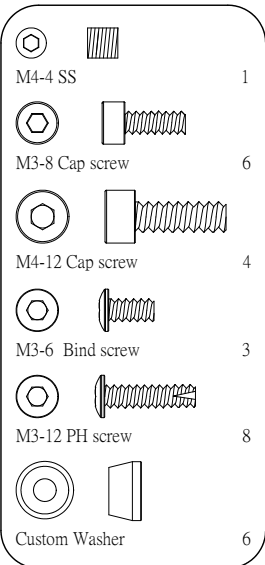

Gear ratio



















12T : 126T = 1 : 10.5	Standard
13T : 126T = 1 : 9.69	
11T : 126T = 1 : 11.45	Not included
14T : 126T = 1 : 9	

8

Elevator Lever Assembly

T-011-11

 Please apply loctite when locking all metal screws .

- | | | |
|---|---|---|
|  |  | 2 |
|  |  | 3 |
|  |  | 4 |
|  |  | 3 |
|  |  | 2 |
|  |  | 1 |
|  |  | 2 |
|  |  | 4 |
|  |  | 2 |

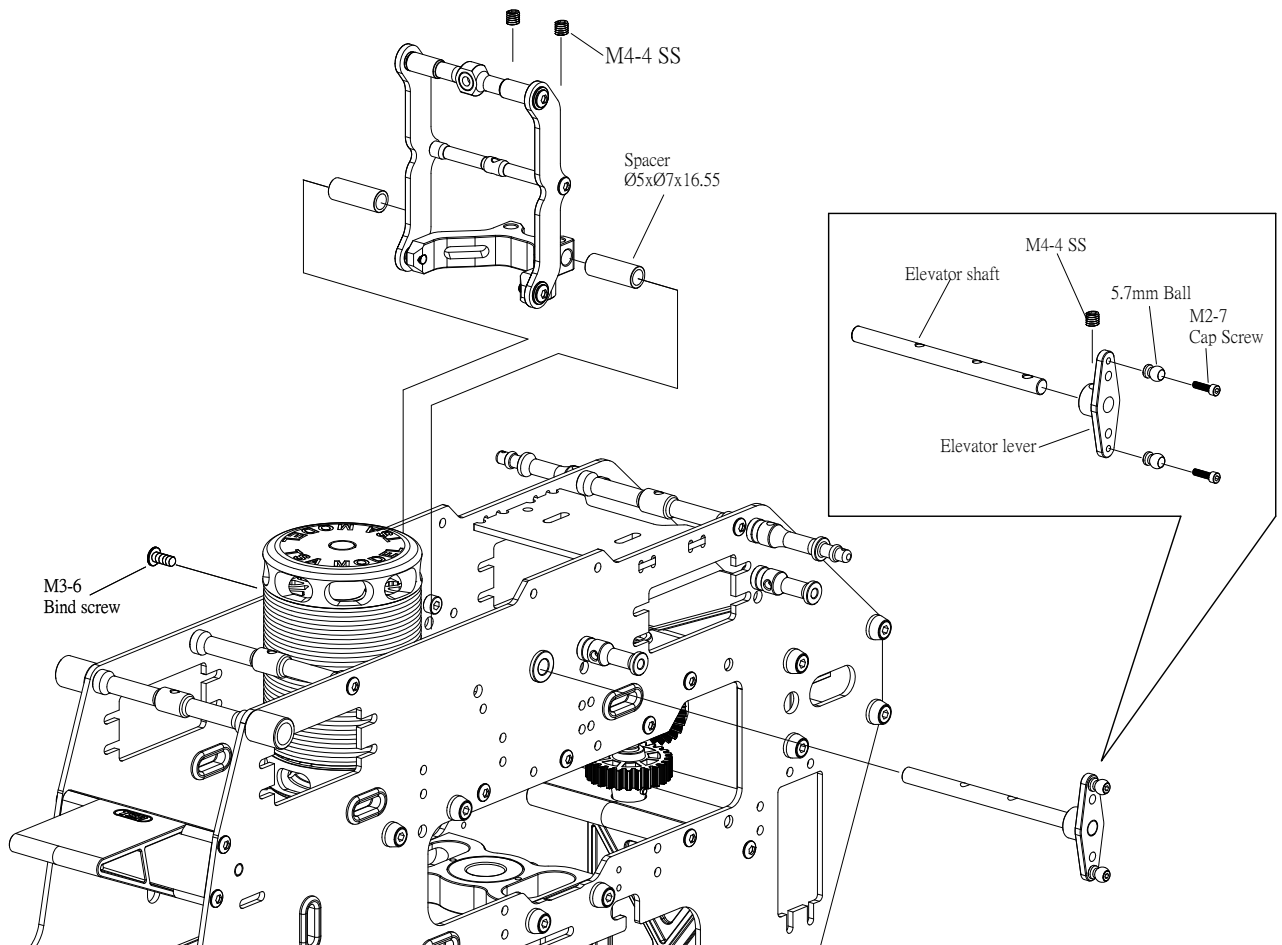
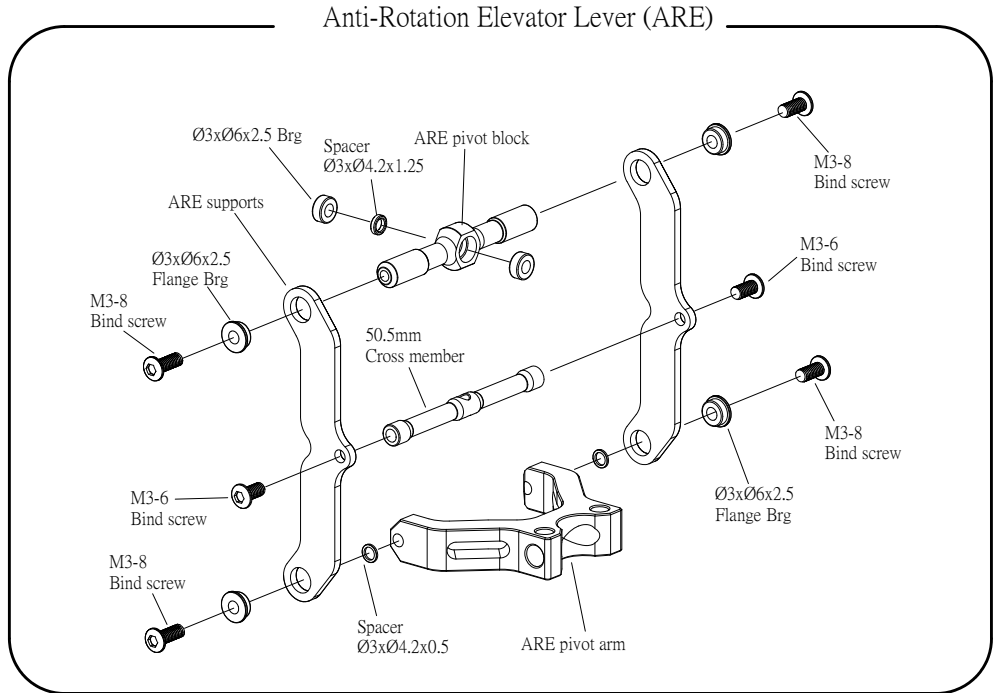

9



Servo Assembly

T-024-01



Caution

Note the orientation of the servos as both the elevator and throttle servo are mounted inside the main frames

- 
M2.6-18 PH screw
12
- 
M2.6-26 PH screw
4

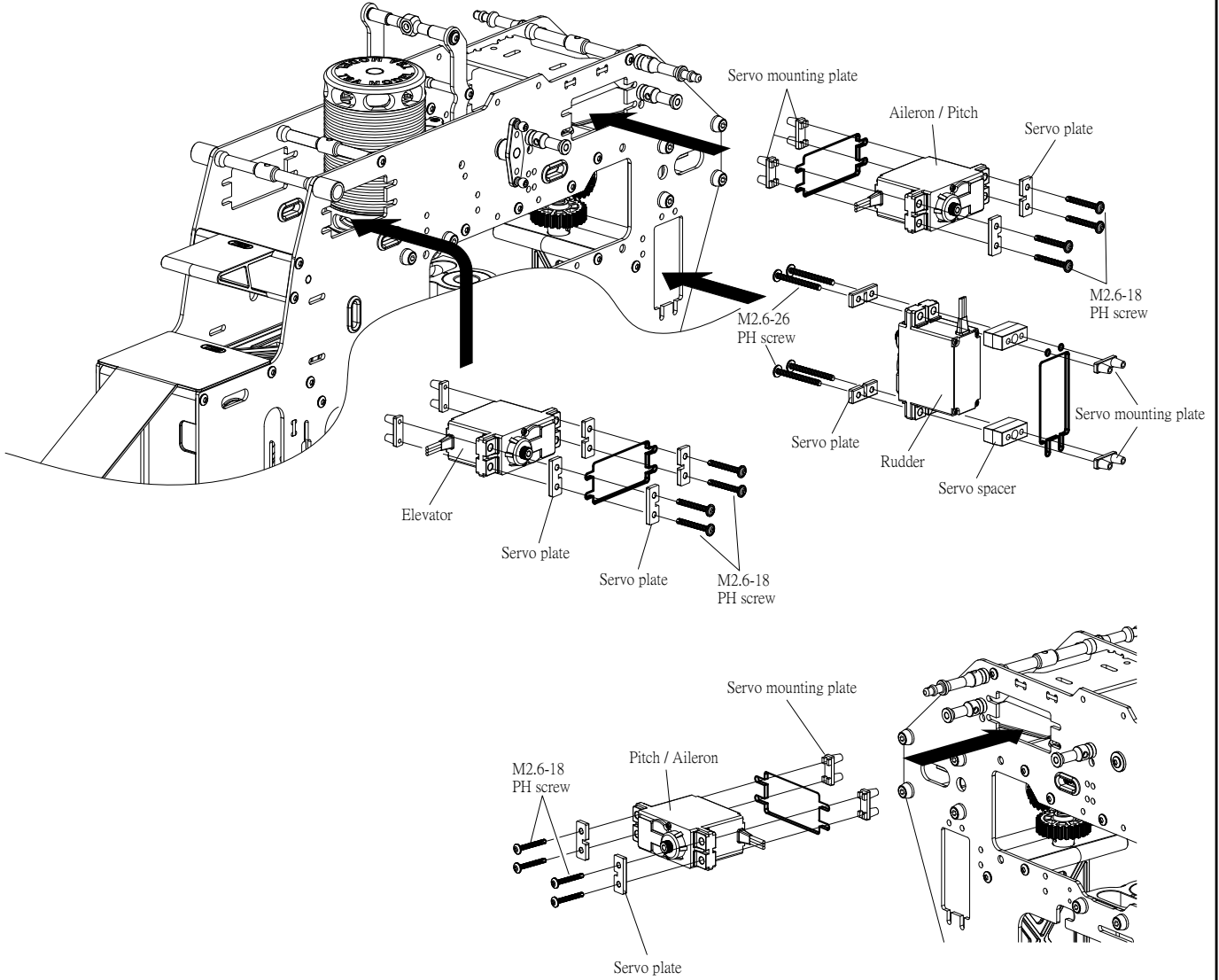

Caution

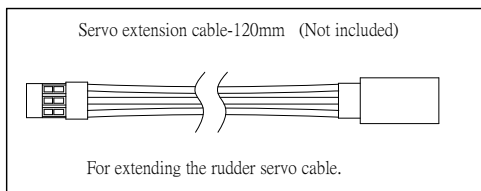
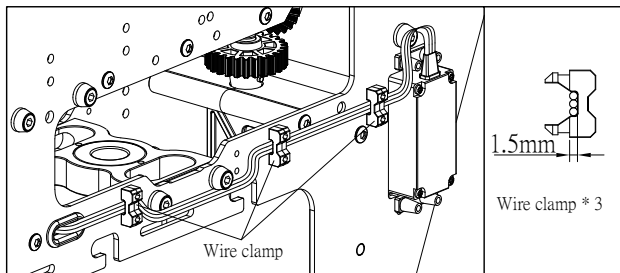

Screw included with the switch

Switch plate

On/off switch

10









Servo Support Assembly

T-020-03

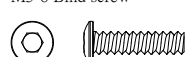
T-022-02

T-025-00

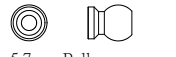
 Please apply loctite when locking all metal screws .

-  M2-8 Cap screw 2
-  M2.6-12 Bind screw 2
-  M3-6 Bind screw 4
-  M3-12 Bind screw 2
-  Ø4xØ7x2.5 Flange Brg 2
-  Servo support guide Ø3xØ6x7 2
-  5.7mm Ball 2
-  13mm Ball 2
-  M2 Nut 2
-  Ball link-long (23mm) 4

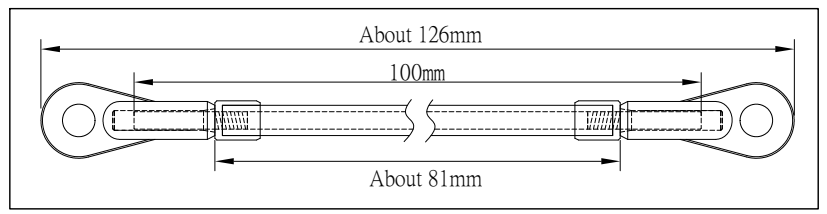
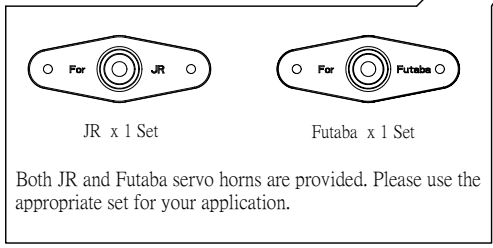
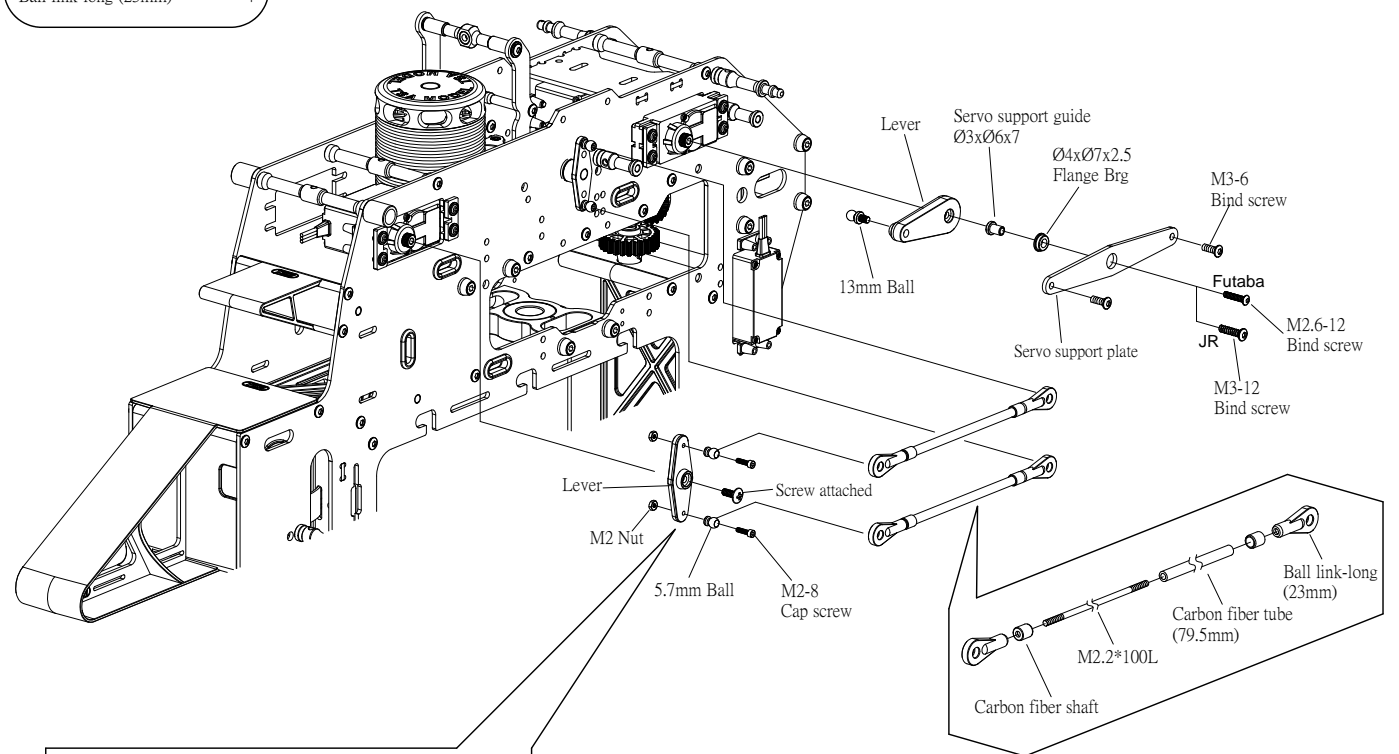
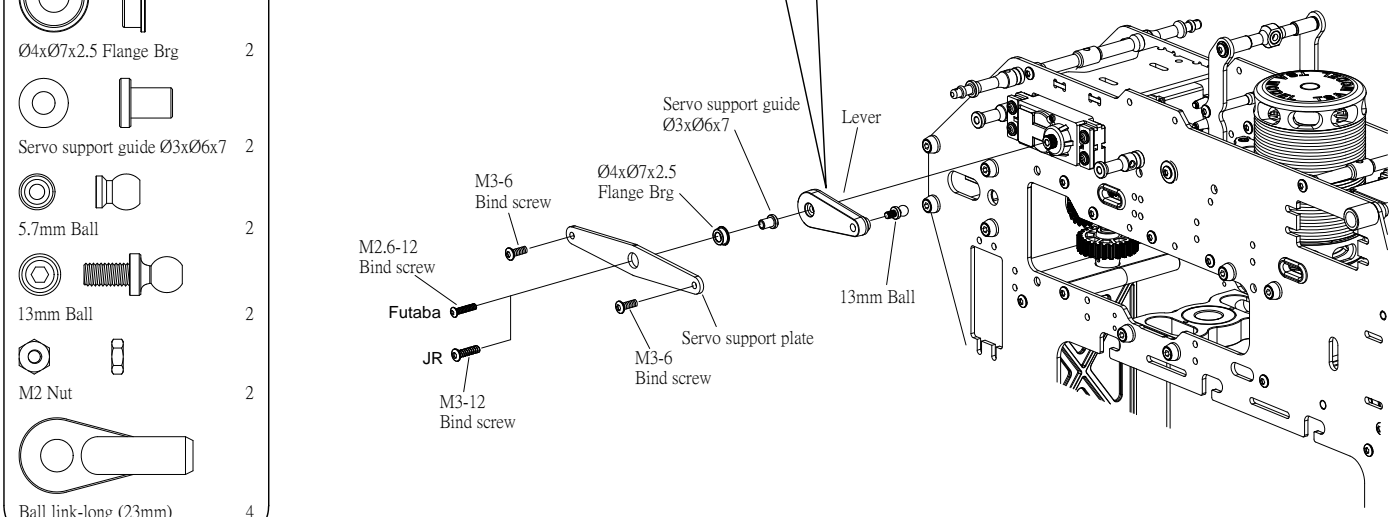
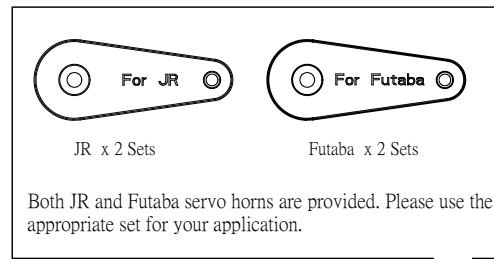

11

Main Gear Assembly

T-007-05

T-015-09

 Please apply loctite when locking all metal screws.

Caution

Only use long shank M4 mounting screw!

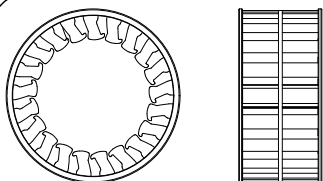
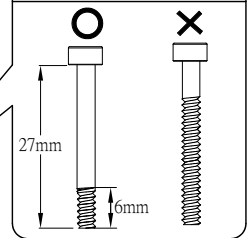

Ø15xØ23x11 One way bearing 1

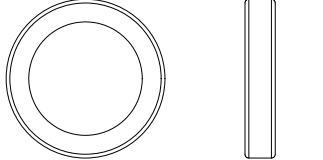

Ø15xØ21x4 Brg 2

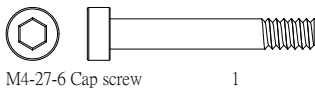

M4-27-6 Cap screw 1



M2-4 Bind Screw 2

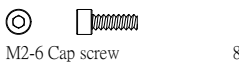

M2-6 Cap screw 8

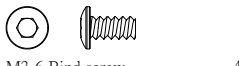

M3-6 Bind screw 4

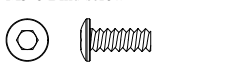

M3-8 Bind screw 6

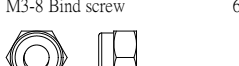

M4 Nylon nut 1

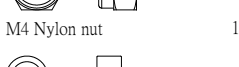

Spacer Ø4xØ5.5x3.25 2

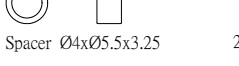

M2 Nut 2

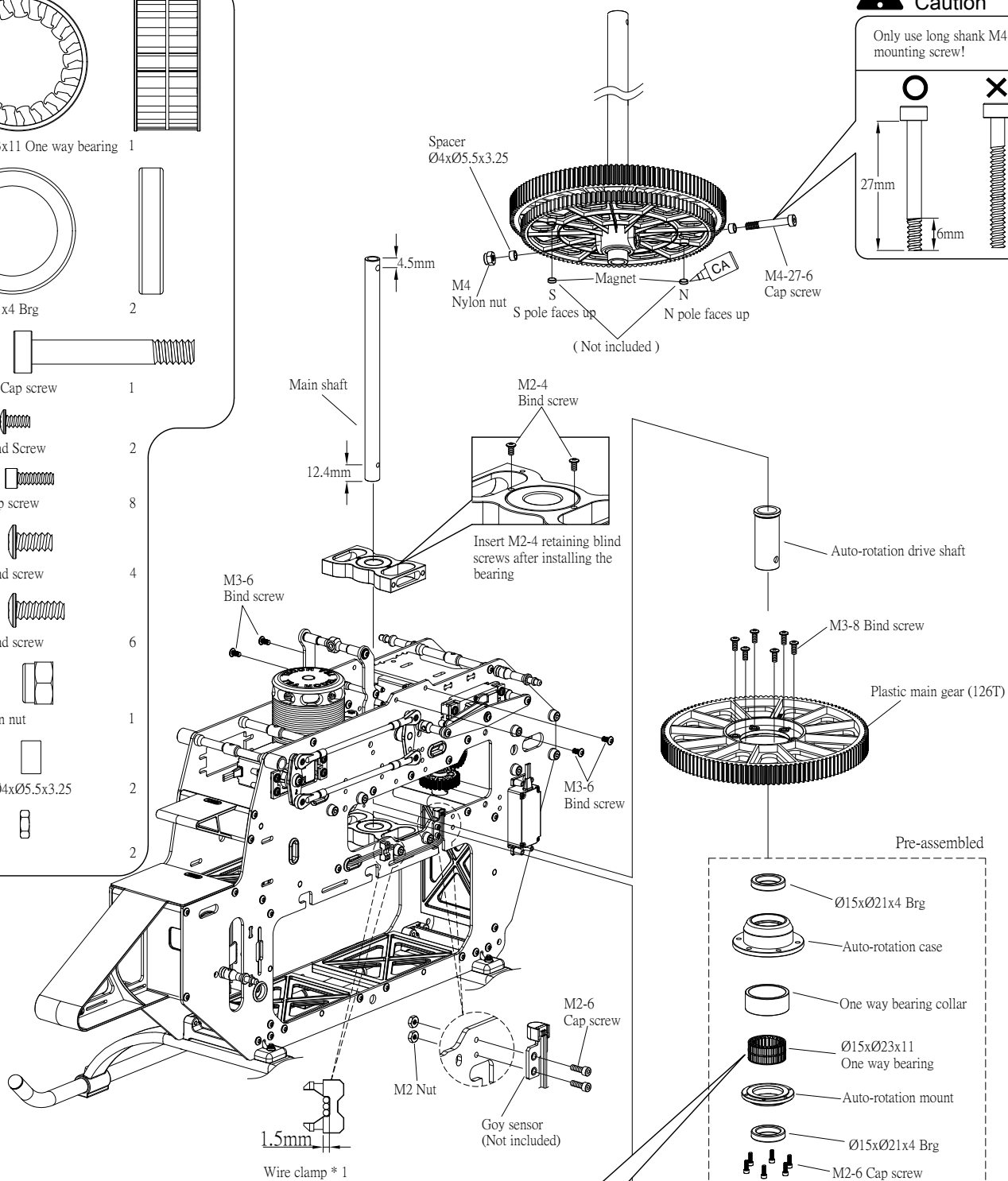

Caution

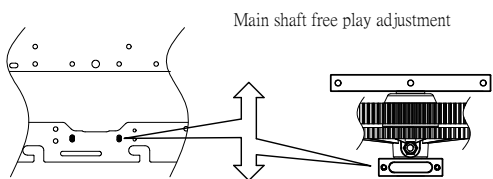

Main shaft free play adjustment

Loosen lower bearing block bolts. Insert main gear assembly and main shaft. While pressing up on the bearing block tighten the 4 lower bearing block bolts. Ensure no up/down free play by pulling on the main shaft.

Please note the direction of bearing.

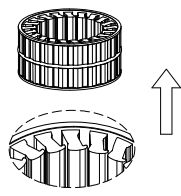



Top view

12

Swashplate Assembly

T-016-07

 Please apply loctite when locking all metal screws .

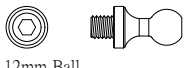
-  M2-4 Bind Screw 4
-  12mm Ball 6

Assembly Tip

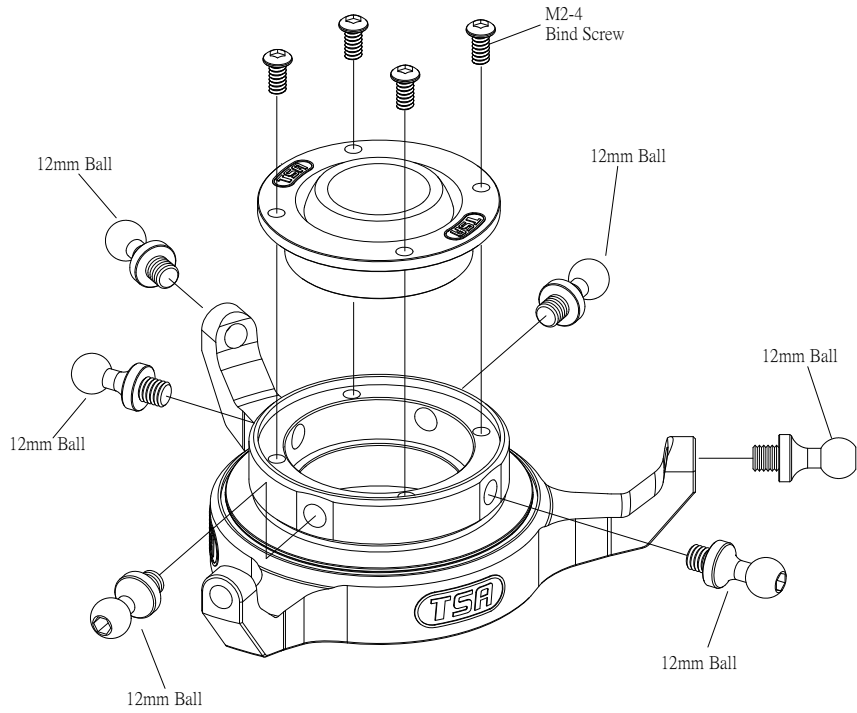
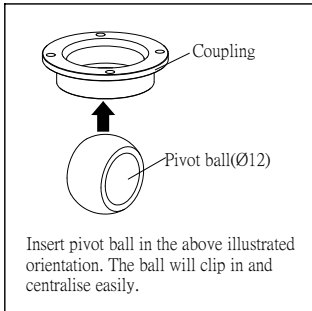

13

Washout Assembly

T-016-07

 Please apply loctite when locking all metal screws .

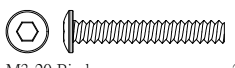
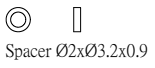
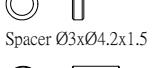
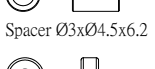
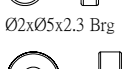
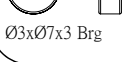
-  M2-6 Bind Screw 4
-  M3-20 Bind screw 2
-  Spacer Ø2xØ3.2x0.9 4
-  Spacer Ø3xØ4.2x1.5 2
-  Spacer Ø3xØ4.5x6.2 2
-  Ø2xØ5x2.3 Brg 4
-  Ø3xØ7x3 Brg 4

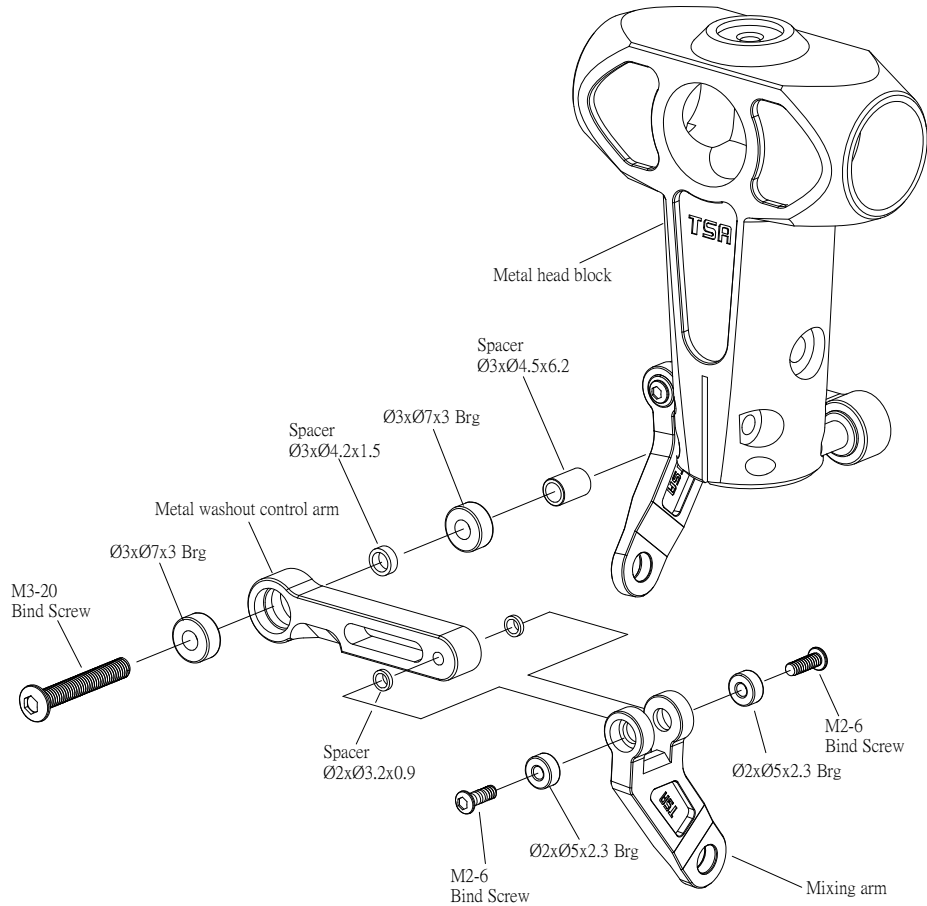

14

Pitch Arm Assembly

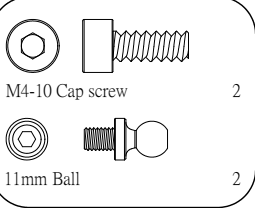

Please apply loctite when locking all metal screws .
T-016-07

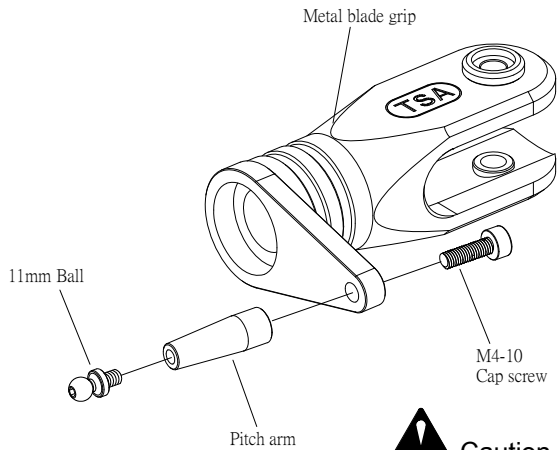

Caution
Two must be assembled

15

Head Block Assembly

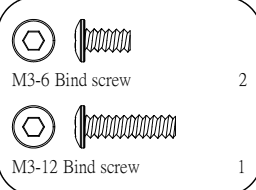

Please apply loctite when locking all metal screws .
T-016-07

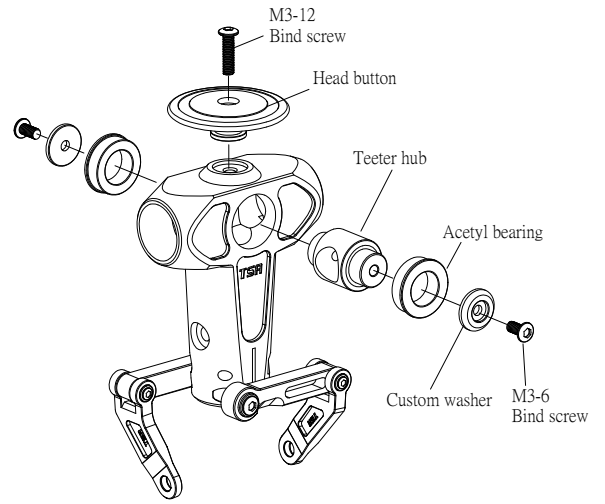

16

Blade Holder Assembly

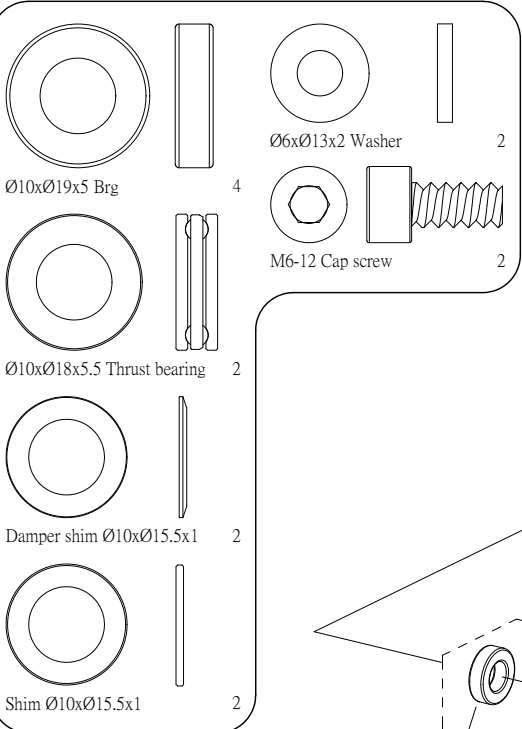

T-016-07

Please apply loctite when locking all metal screws .

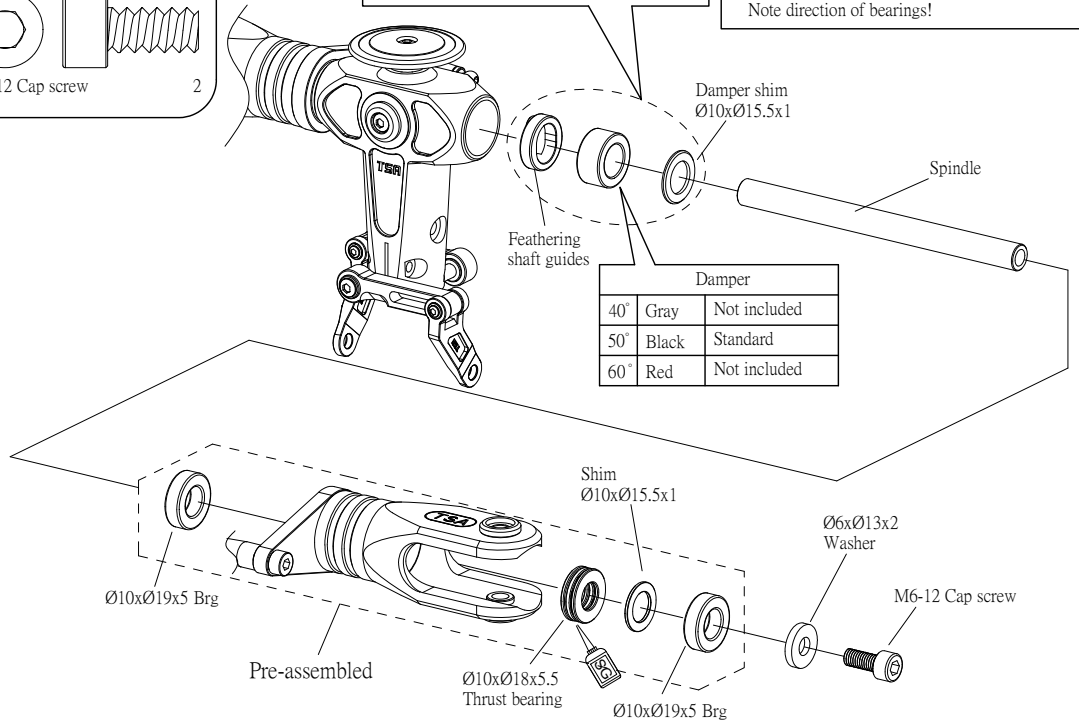
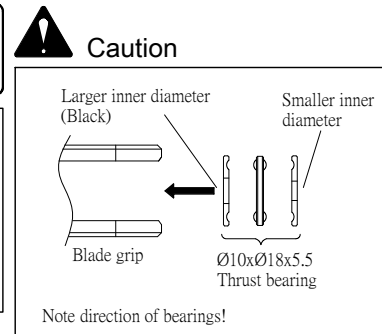
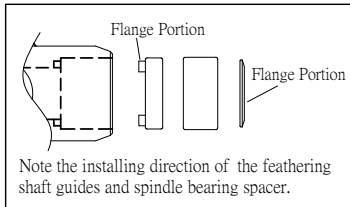

17

Rotor Head Complete Assembly

T-011-11
T-016-07
T-020-03

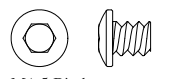
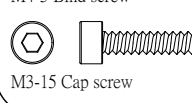
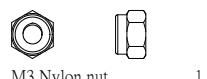
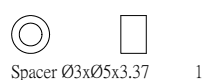
-  1
-  2
-  2
-  1
-  1

 Please apply loctite when locking all metal screws .

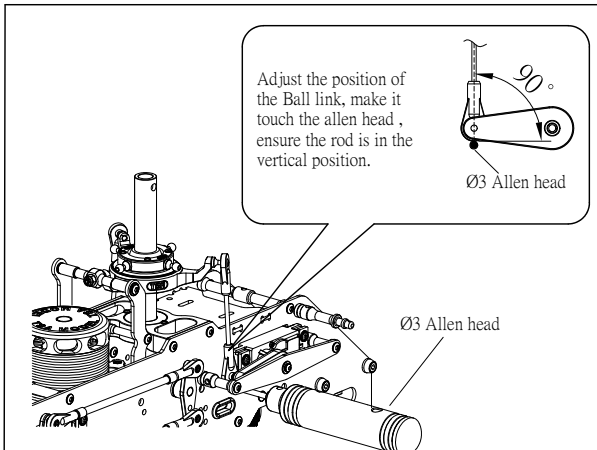
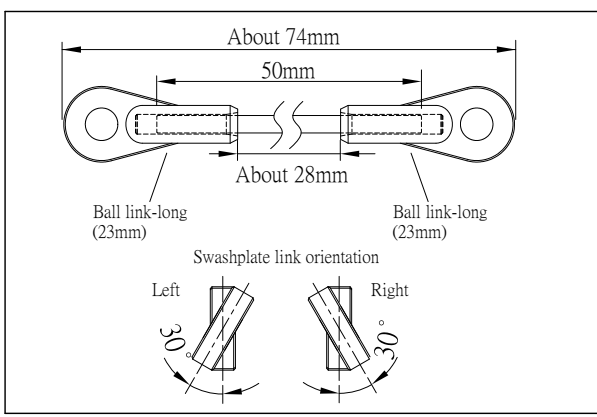

Insert the allen head into the hole as shown in the diagram, make sure the rocker-arm is parallel with the swashplate.

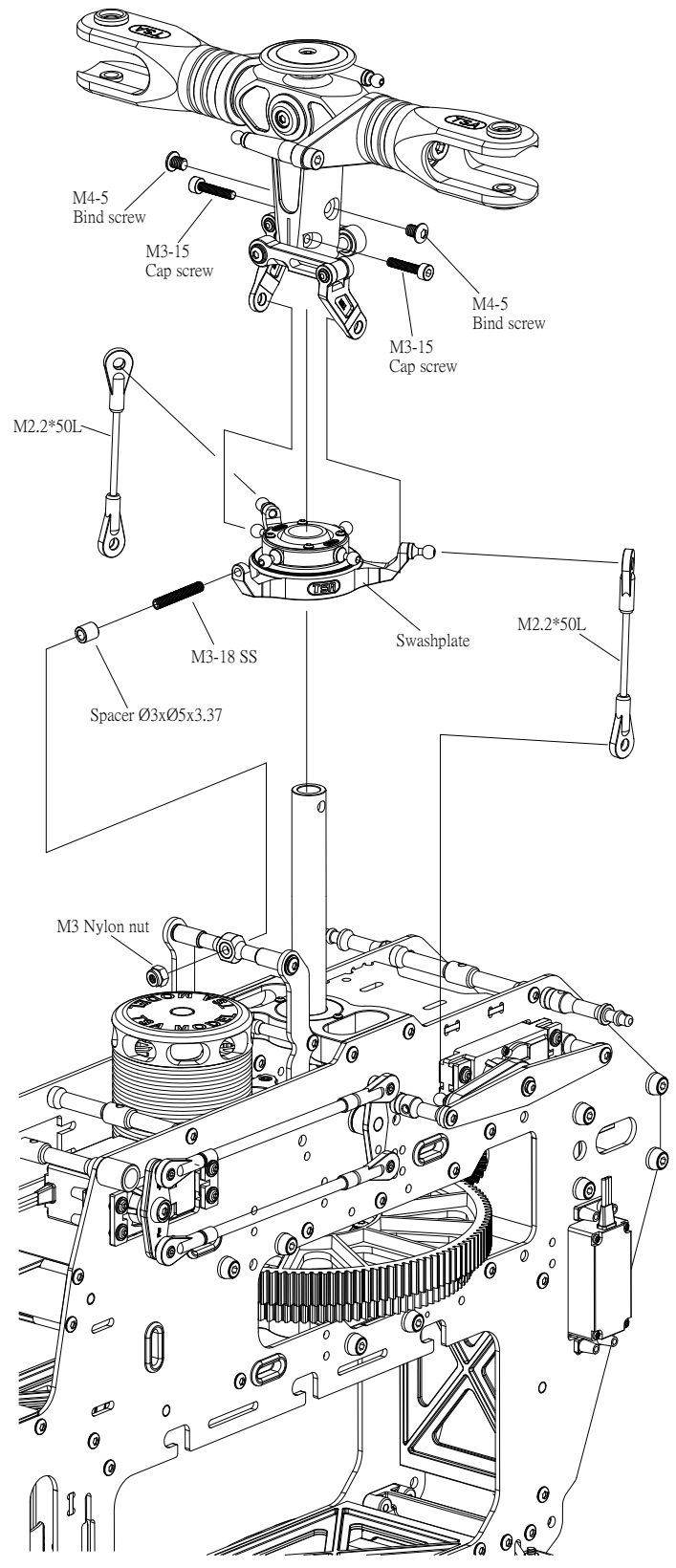
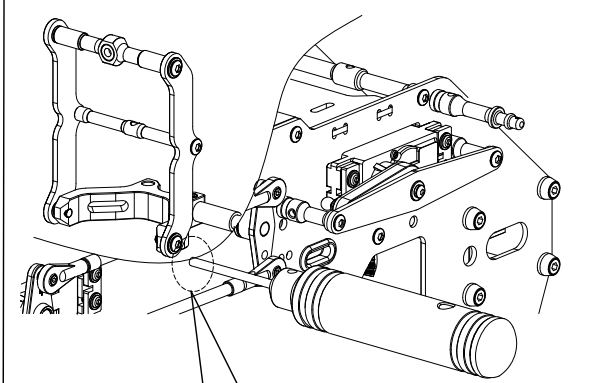







18

Tail Gearbox Assembly-1

T-016-07

 Please apply loctite when locking all metal screws .

-  1
-  1
-  7
-  1
-  1
-  2
-  1

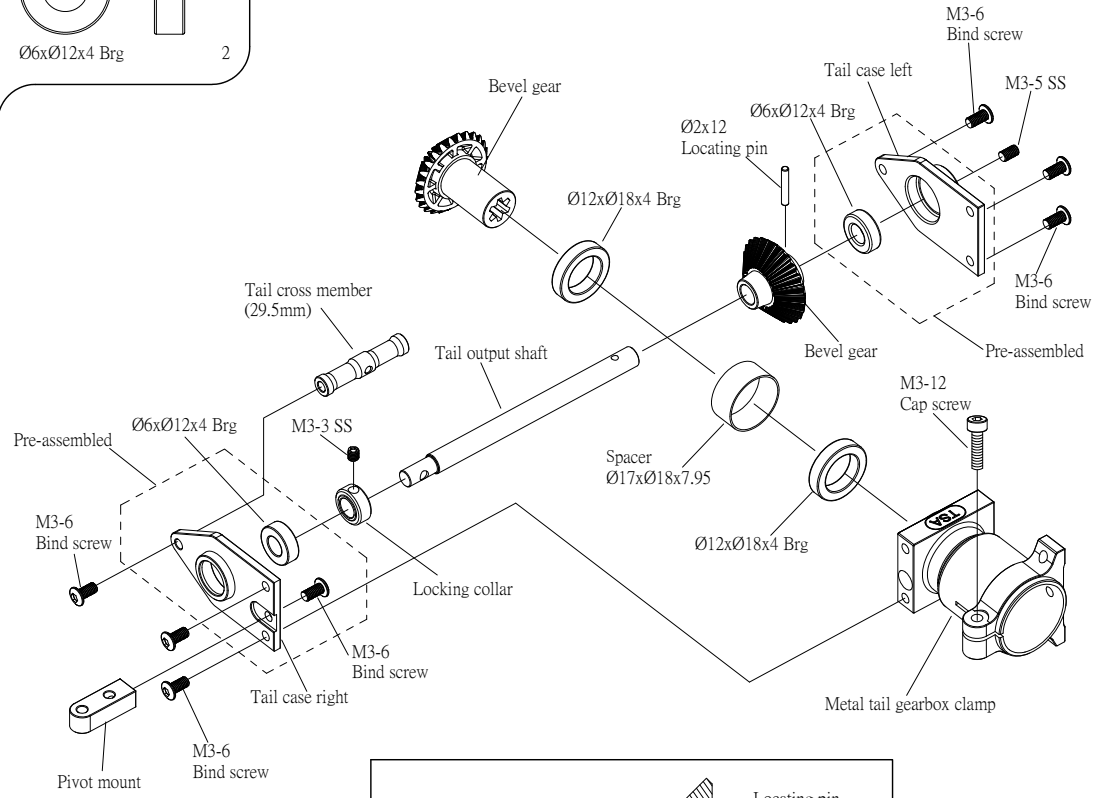

Centralise the locating pin on each gear then tighten the M3-5SS grub screws. Ensure correct orientation.

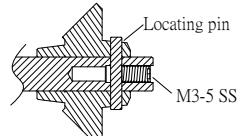







19

Tail Gearbox Assembly-2

T-017-02

 Please apply loctite when locking all metal screws .

-  2
-  1
-  1
-  2
-  1
-  2

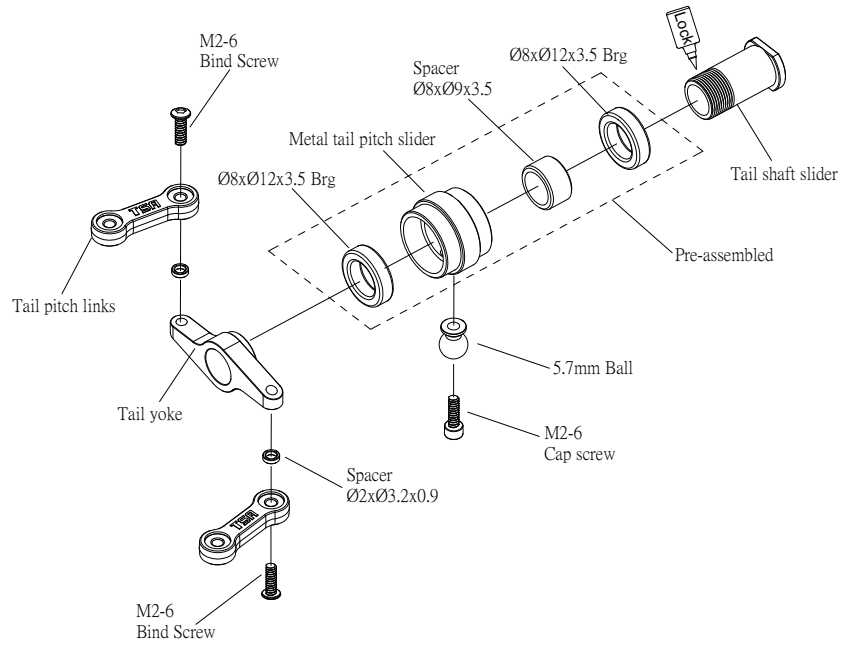

20

Tail Gearbox Assembly-3

T-018-00

Please apply loctite when locking all metal screws .

- M2-8 Cap screw 1
- M3-18 Bind screw 1
- 5.7mm Ball 1
- M2 Nut 1
- Spacer Ø3xØ5x4.5 1
- Spacer Ø3xØ4.5x3 1
- Ø3xØ7x3 Brg 2

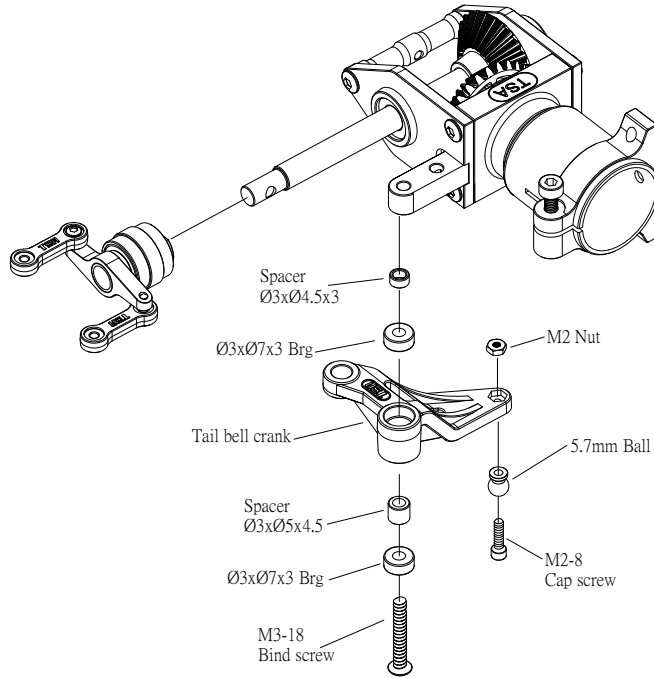

21

Tail Gearbox Assembly-4

T-016-07

Please apply loctite when locking all metal screws .

- M3-17-5 Cap screw 2
- M3 Nylon nut 2
- M4 Nylon nut 2
- Ø5xØ10x4 Thrust bearing 2
- Ø6xØ12x4 Brg 2
- Ø5xØ10x4 Brg 2

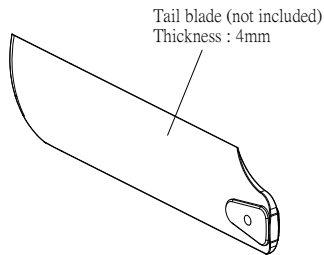

Caution

Note direction of bearings!
Periodically check and perform necessary lubrication.

Caution

Only use long shank M3 mounting screw!

17mm

5mm

Caution

Fasten the tail blade to permit only slight movement .
Note the direction of the tail blade and the tail blade grip .

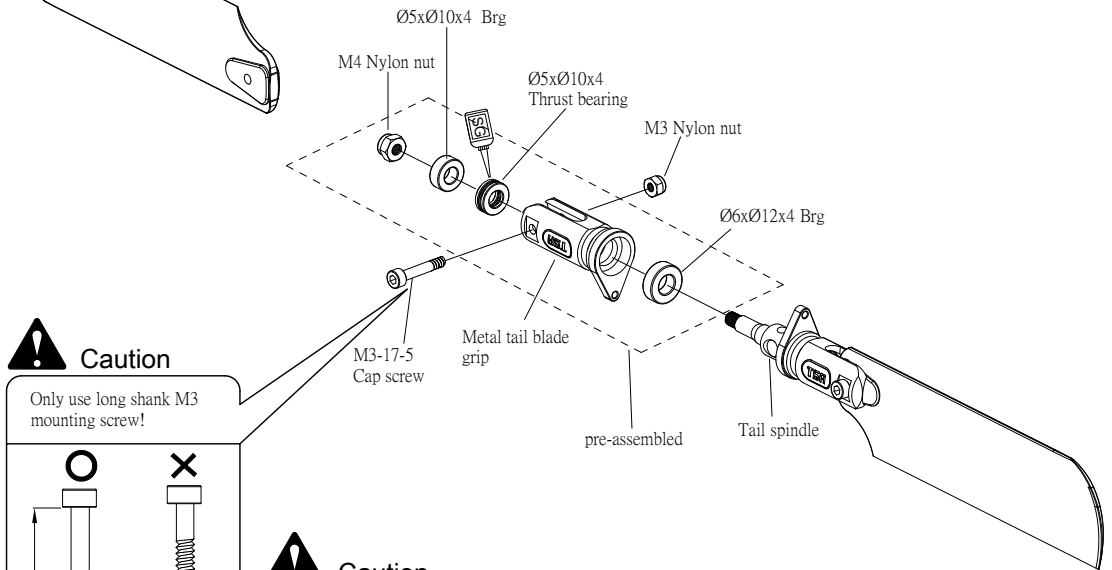





22

Tail Gearbox Assembly-5

T-016-07

T-017-02

 Please apply loctite when locking all metal screws .

-  M4-4 SS 1
-  M2-6 Bind Screw 2
-  Spacer Ø2xØ3.2x0.9 2

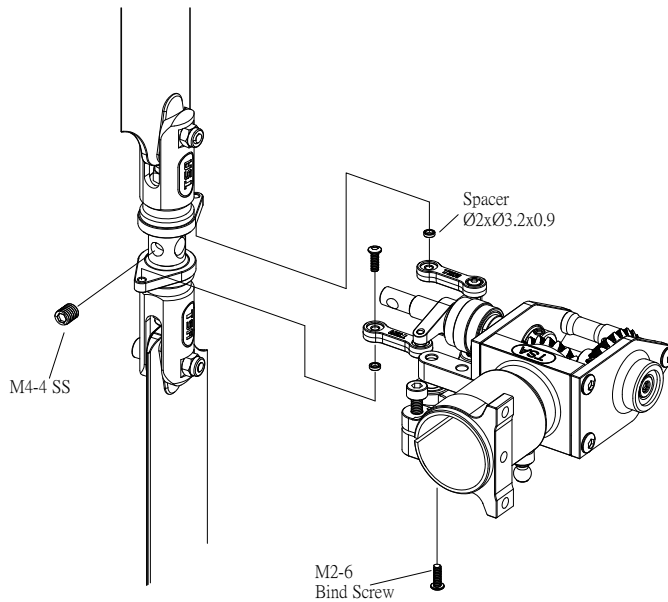

Caution

Use the M4-4SS screw to fasten the tail shaft and spindle. Ensure grub screws are seated into receiver grooves.

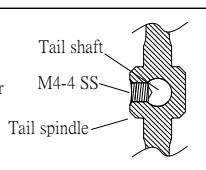

23





Tail Gearbox Assembly-6

T-026-01

T-027-02

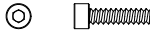
T-028-22

 Please apply loctite when locking all metal screws .

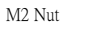
-  M2-8 Cap screw 4
-  M3-5 Bind screw 2
-  M3-10 Cap screw 1
-  M2 Nut 4
-  Ø8xØ14x4 Brg 2

Torque tube bearing location :

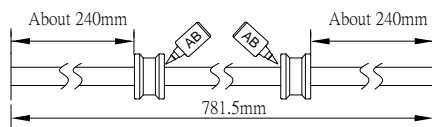

Apply AB glue to shaft then slide bearing overtop and allow to dry.

Assembly Tip

Apply oil to tail boom bearing carrier and inside tail boom for easy T/T installation.

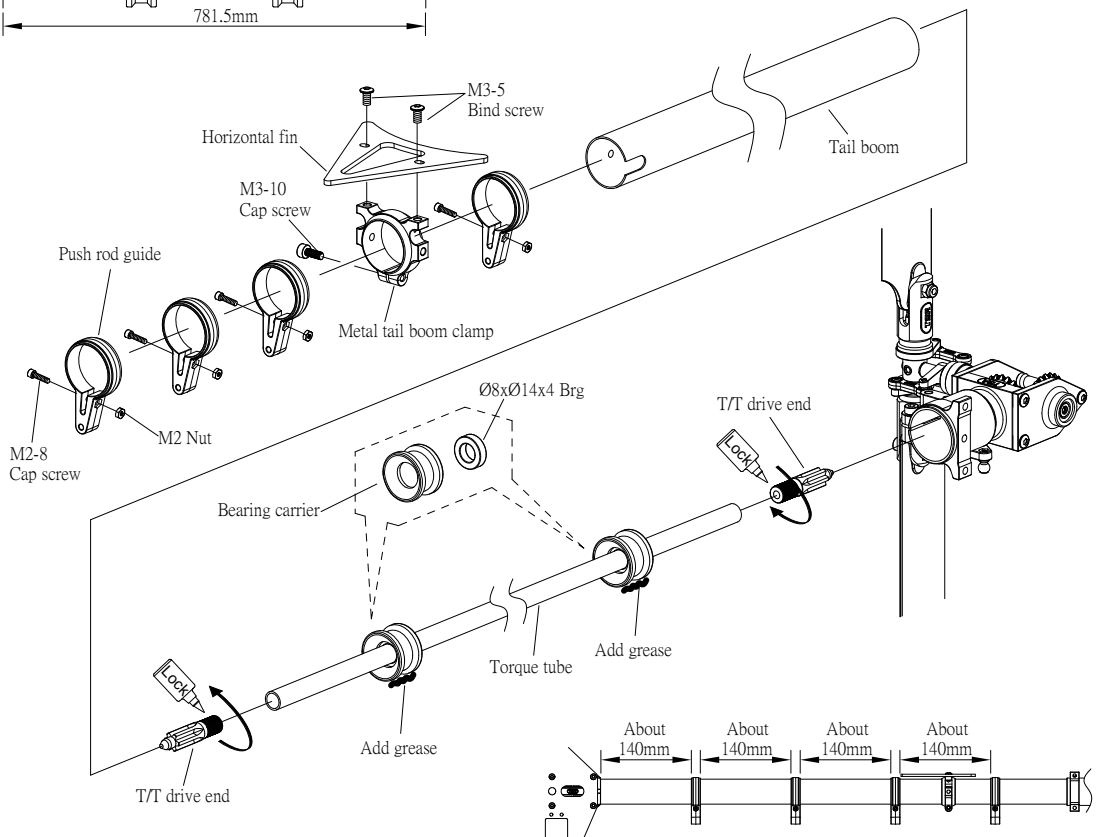

24

Tail Boom Support Assembly

T-002-07











T-016-07

T-026-01

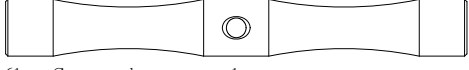
T-027-02

T-028-22

 Please apply loctite when locking all metal screws.

-  4
-  4
-  4
-  1
-  1
-  4
-  1
-  2
-  1
-  2
-  2

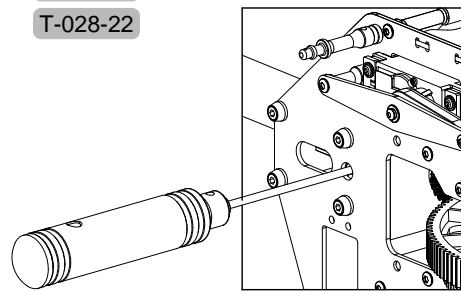

After inserting the tail boom tighten the previously installed retaining screw.

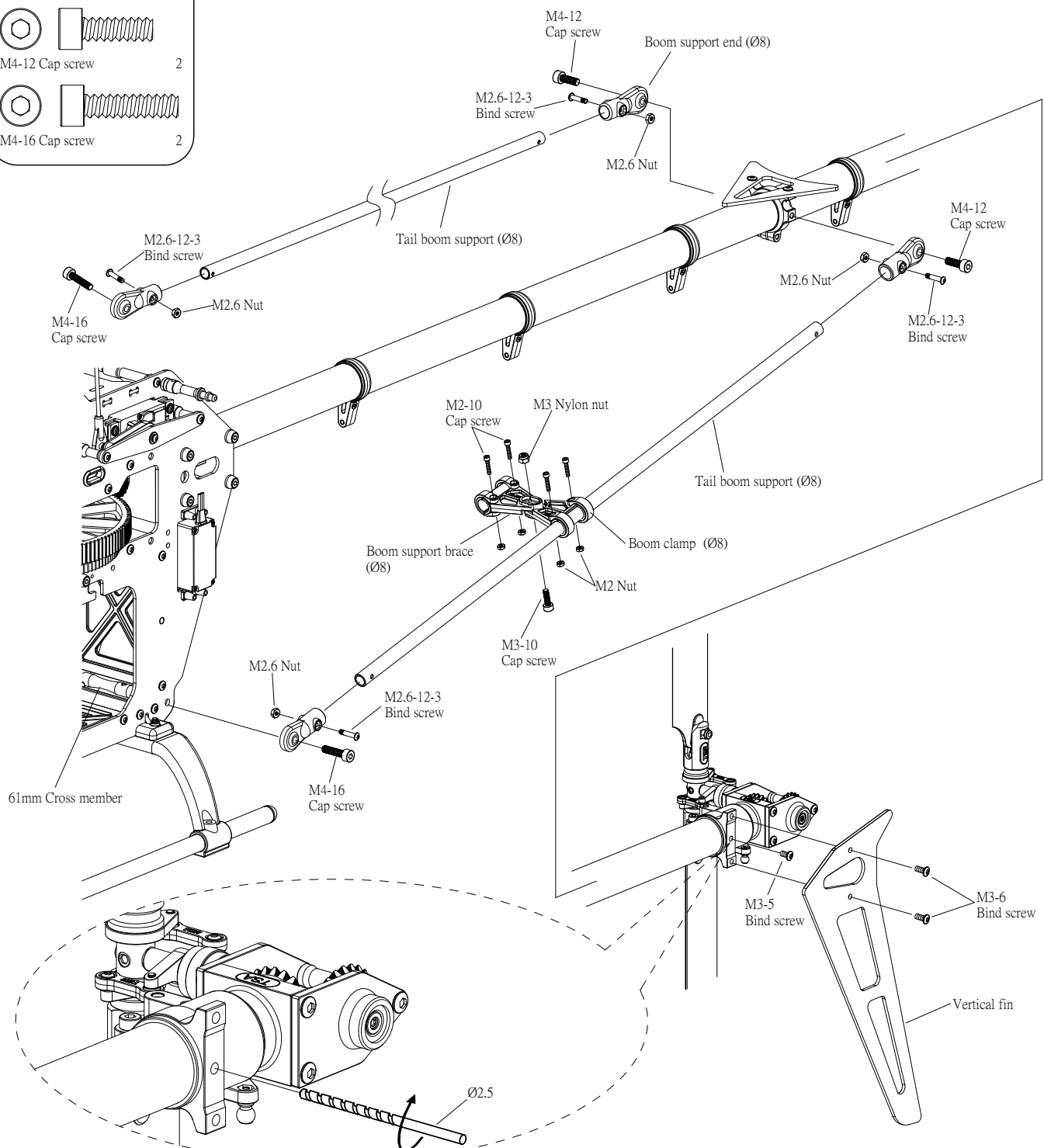

25

Rotor Head Linkage Assembly

T-016-07

 Please apply loctite when locking all metal screws .

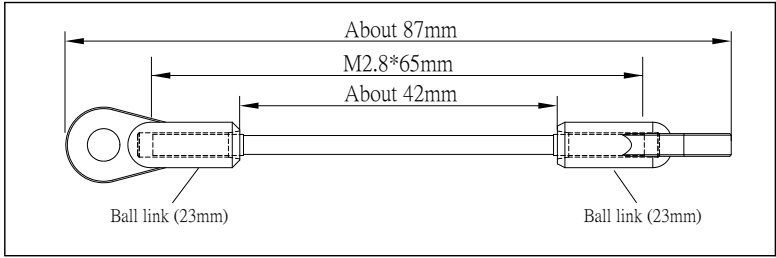
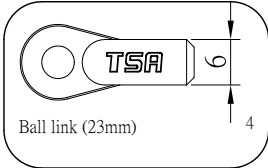

Caution

Measure the pitch angle after assembly of the blades, and then make the adjustment .

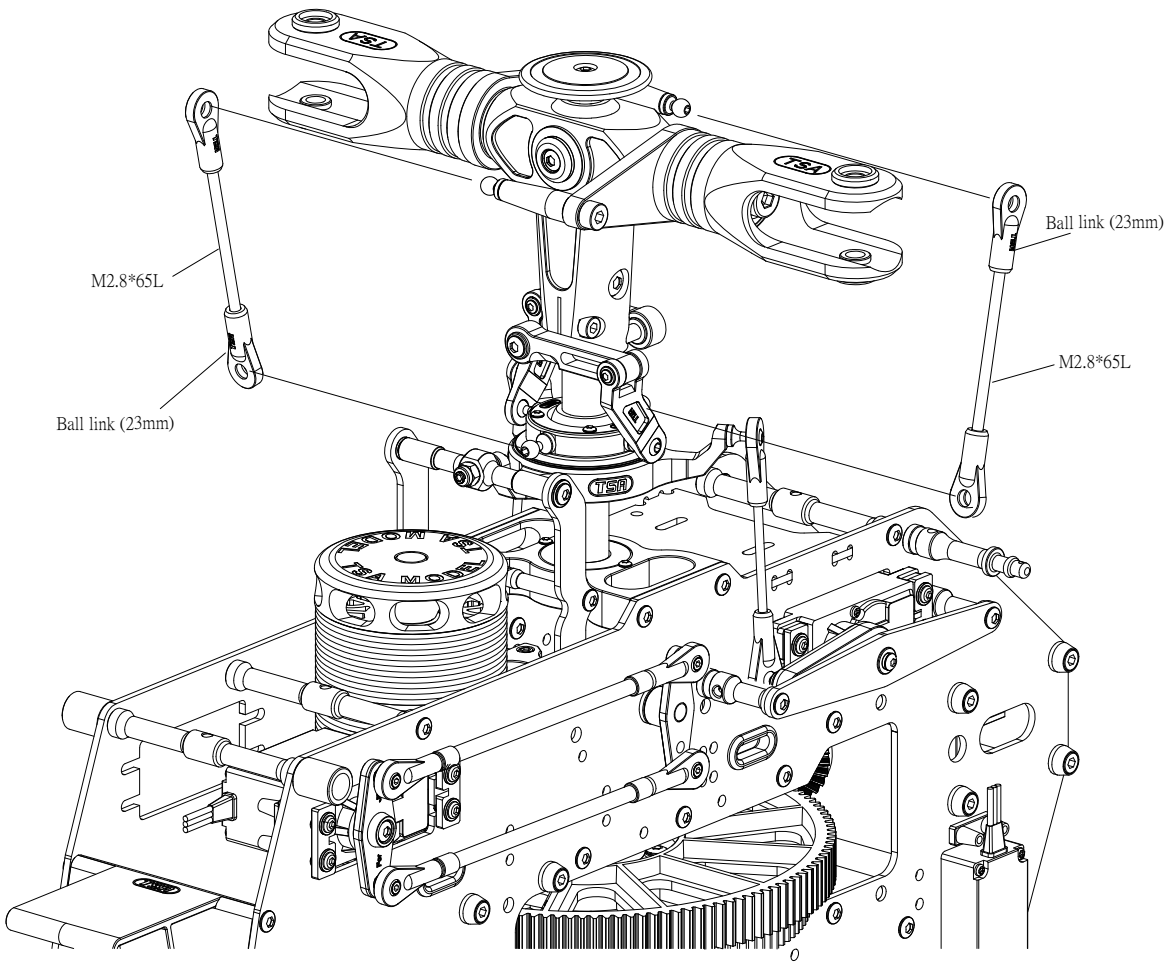

26







Rudder Linkage Assembly

T-024-01

T-027-02

T-028-22

 Please apply loctite when locking all metal screws .

-   1
-   1
-   1

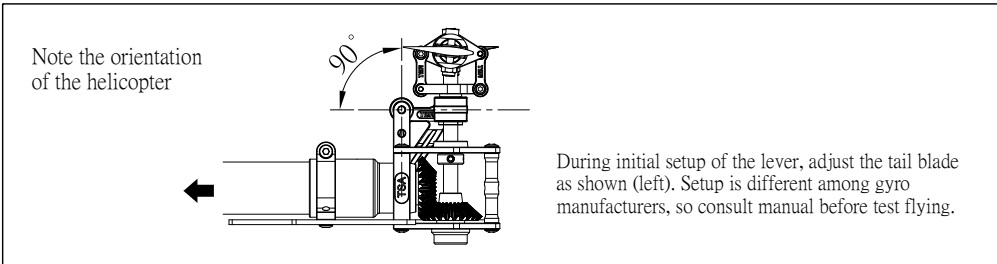
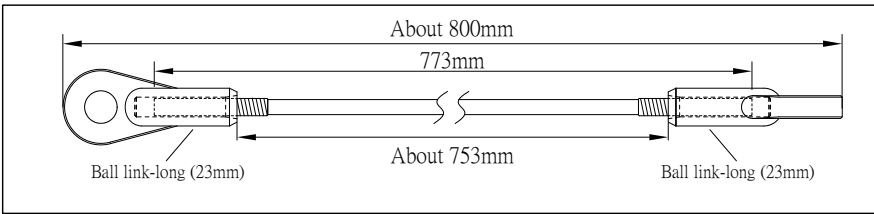
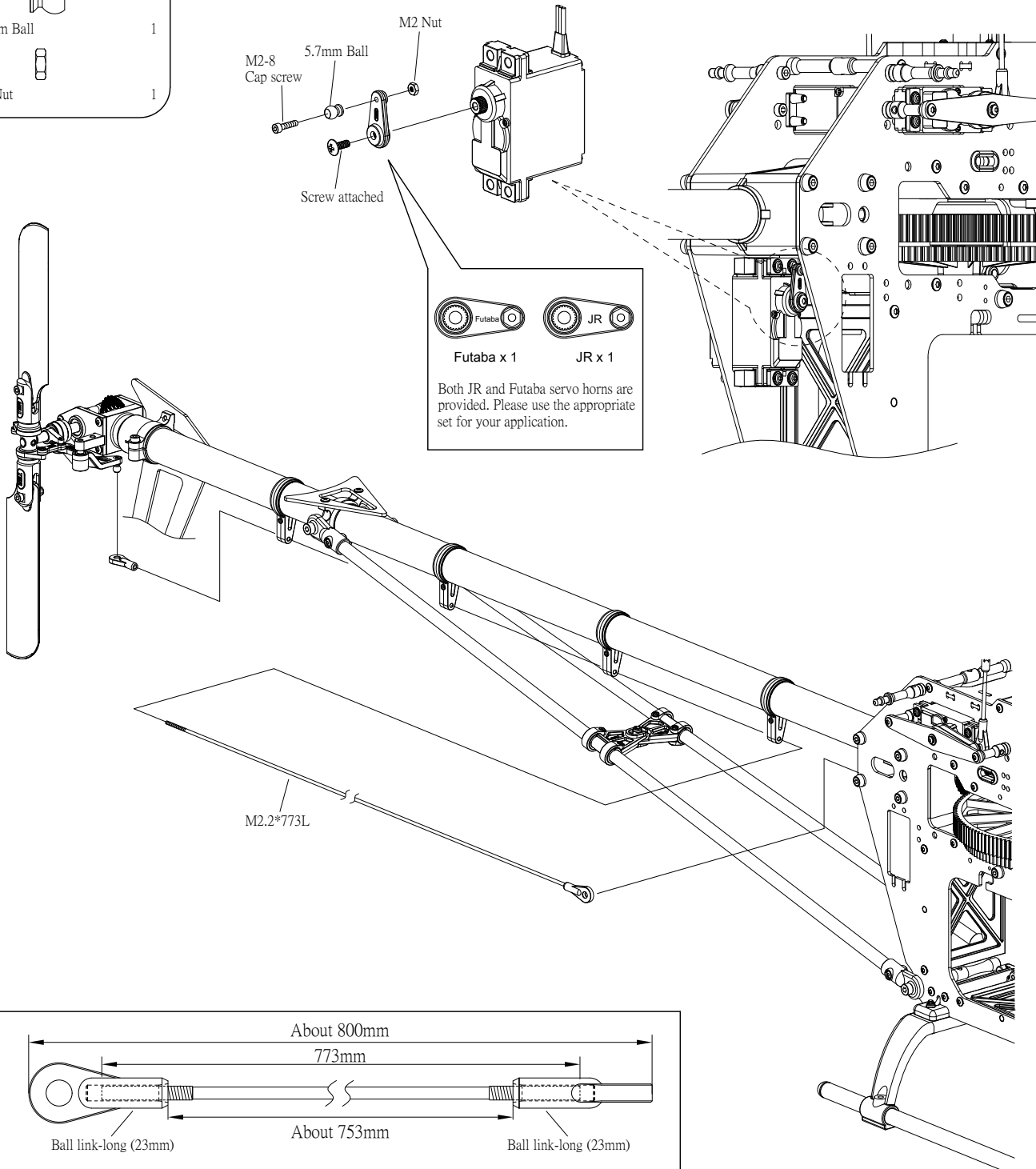
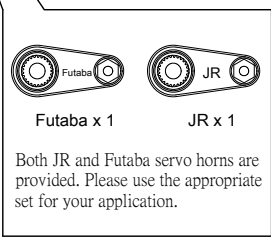
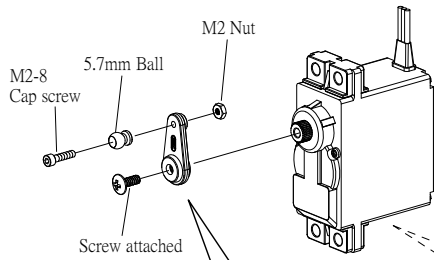

27

Main Blade Assembly

T-016-07



M5-32-6 Cap screw

2

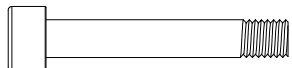

M5 Nylon nut

2



Caution

Only use long shank M5 mounting screw!

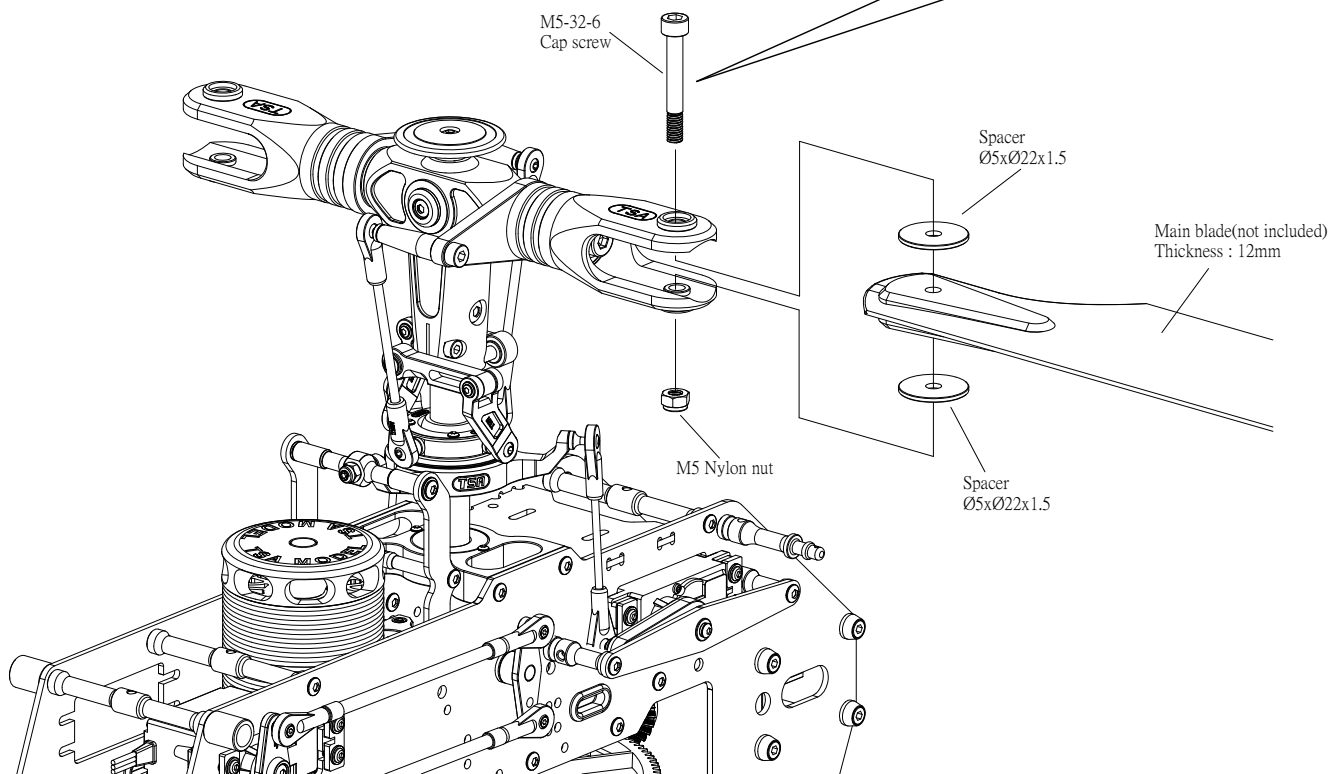
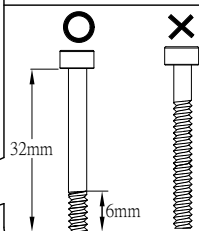

28

Receiver and Gyro Assembly

For JR

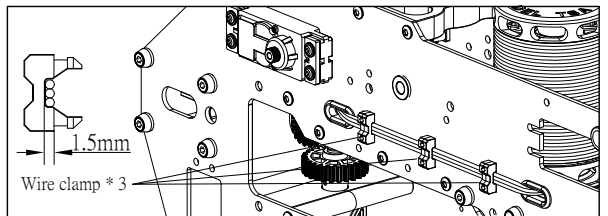
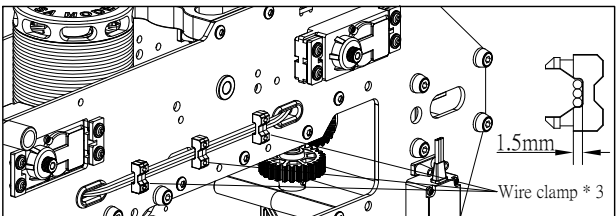
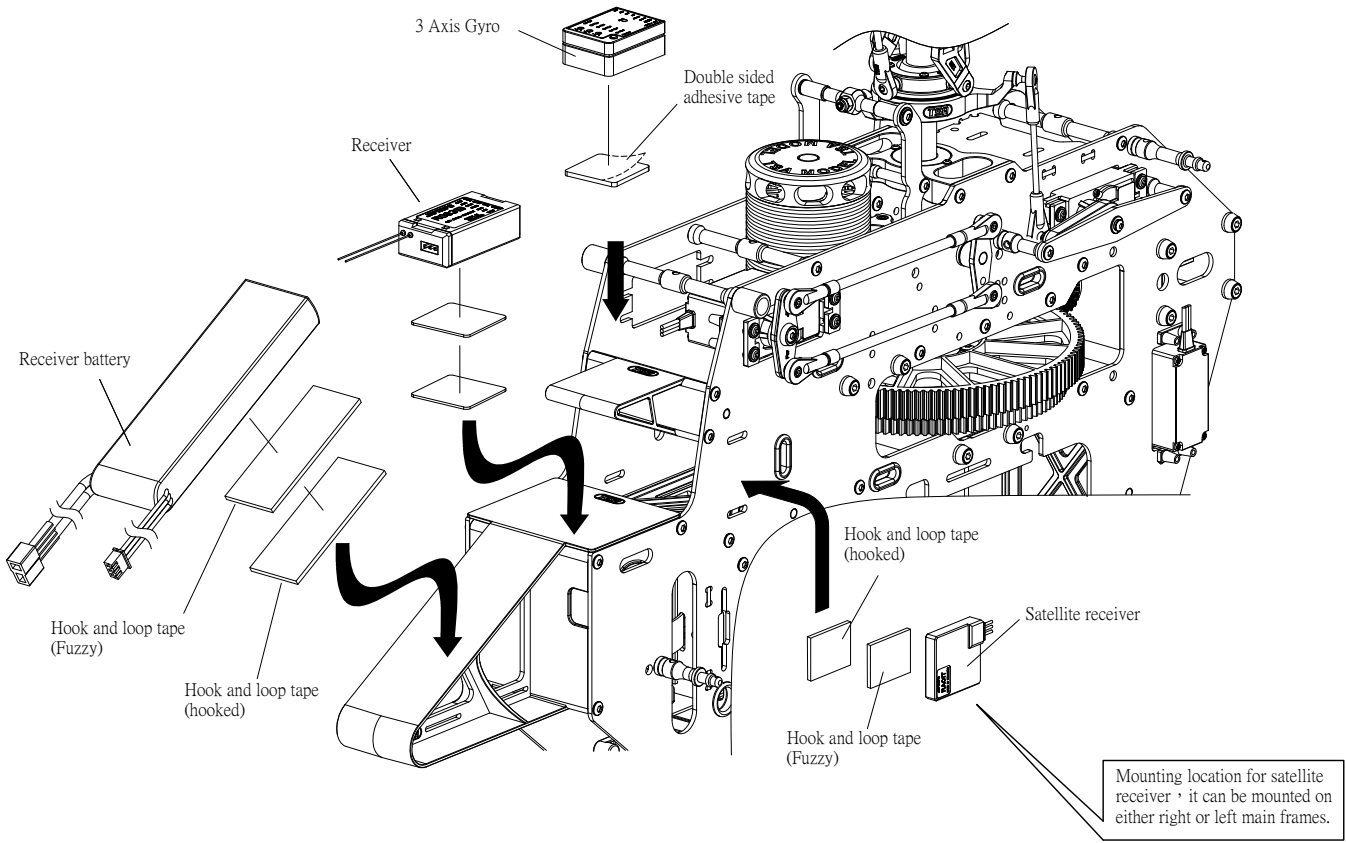
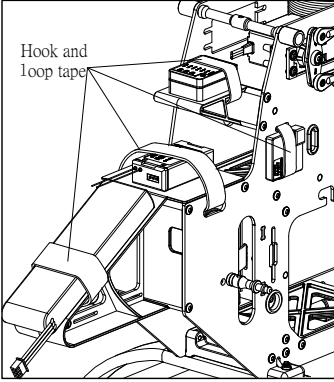

29

Electrical Control System Wiring Diagram

JR / 7CH receiver wiring

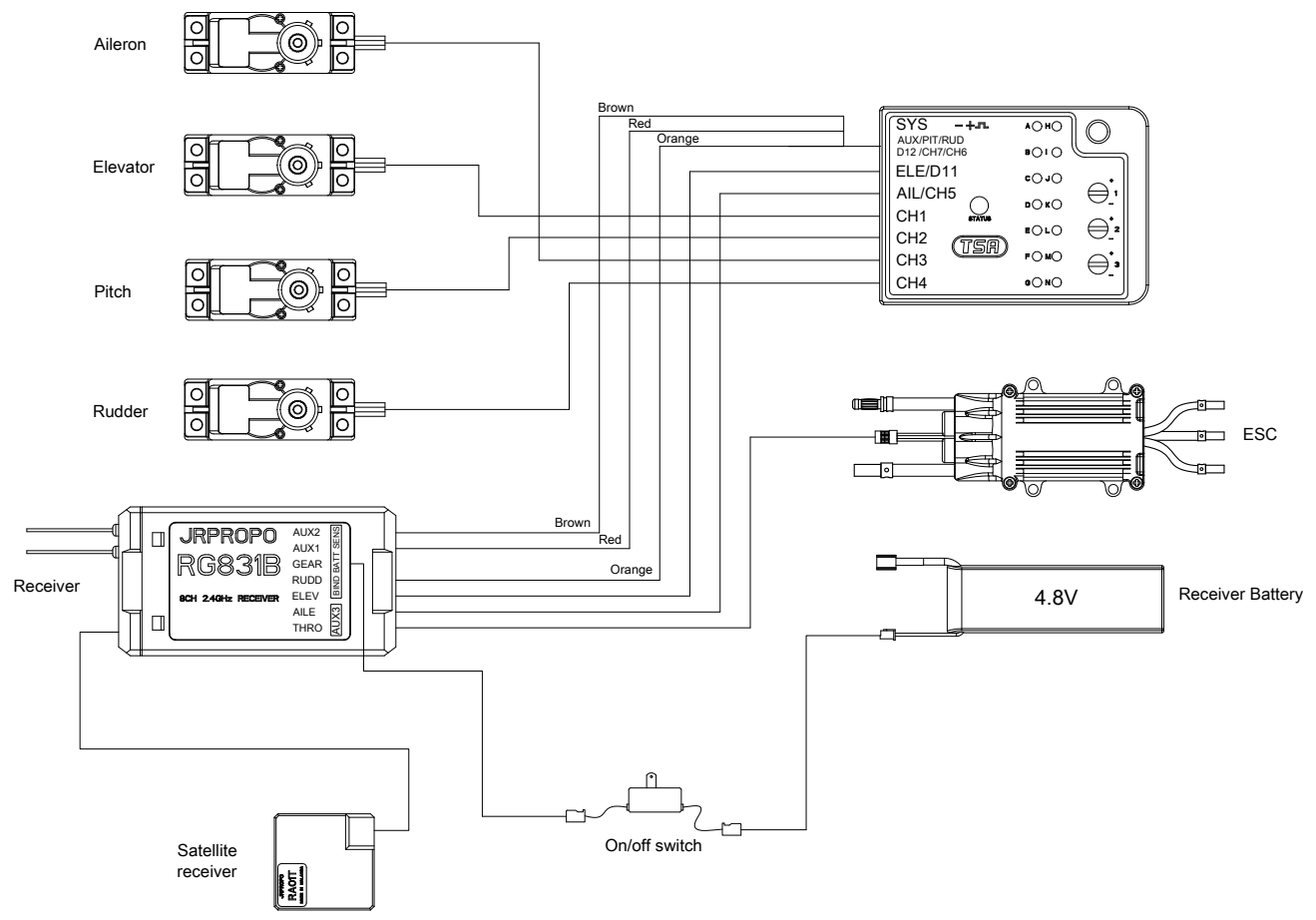

30

Battery Assembly

T-029-01

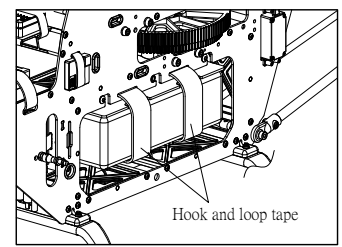
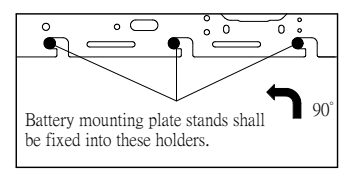
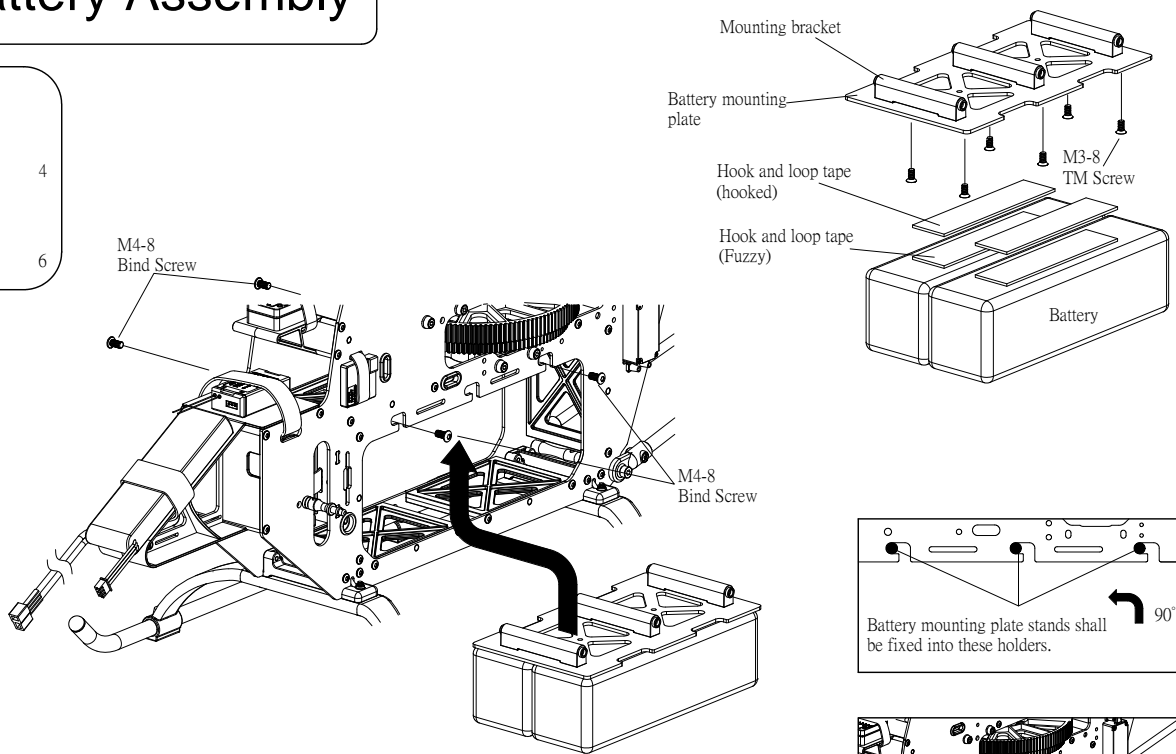
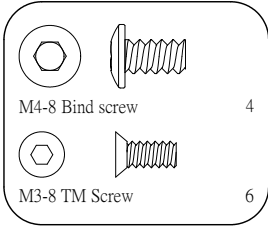

- 1: Adhere double sided tape to the back side of the battery, and then taped on the battery mounting plate, make sure the battery is fixed in the center of the plate.
- 2: Use hook and loop tape to enhance the fixing between battery and fuselage, so that to avoid battery lose resulting from vibrate of fuselage while flying.

Wiring illustration

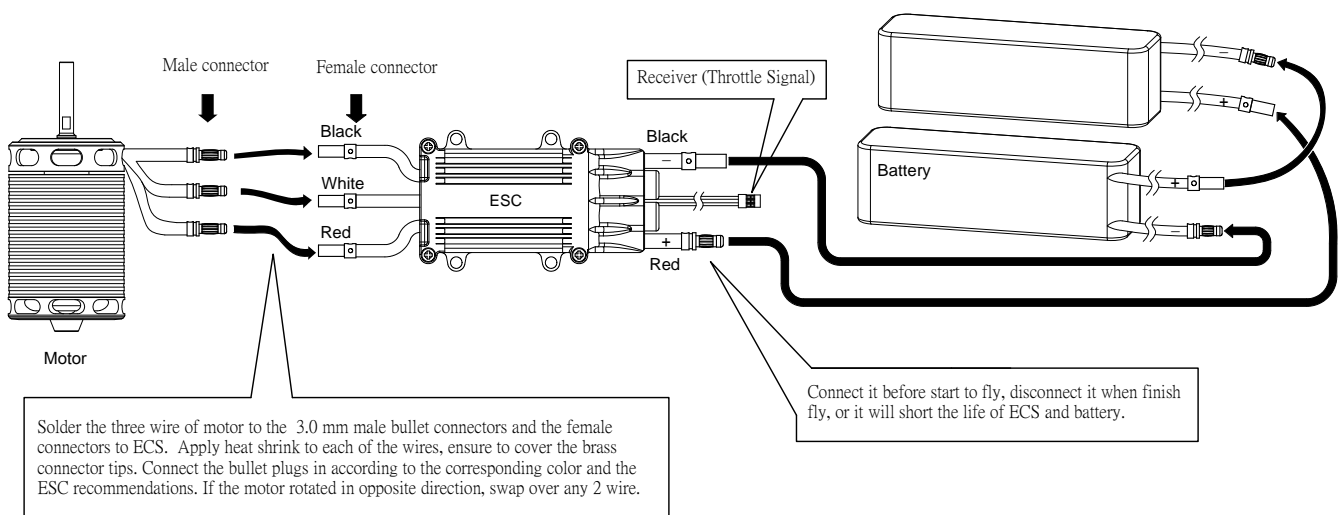

THE CAUTIONS FOR MOTOR

- 1: Please do not disassembly the motor unless recommended by the manufacturer for bearing replacement only. Permanent damage may occur otherwise.
- 2: The use of multiple batters alternating between cooler packs is recommended. Also allow batteries to cool before charging. Please allow sufficient time for the motor and ESC to cool down after flying. As back to back flights may shorten the life spand.

31

Canopy Assembly

T-005-01

Optional custom designed canopies are available. Please check website for availability.

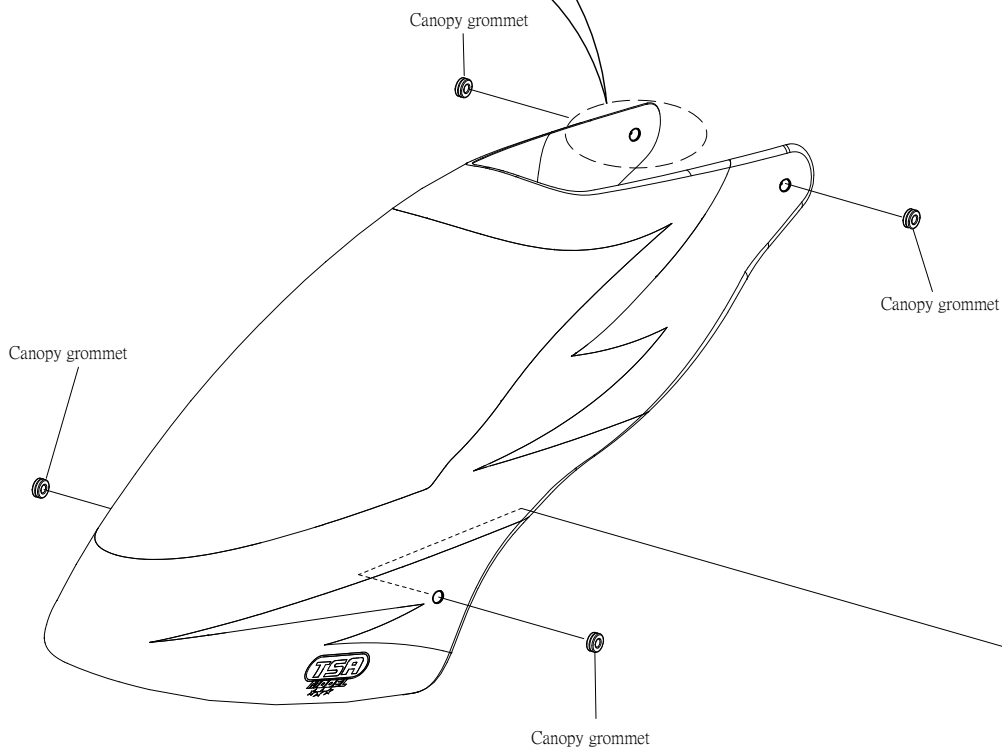
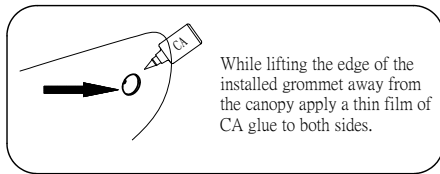
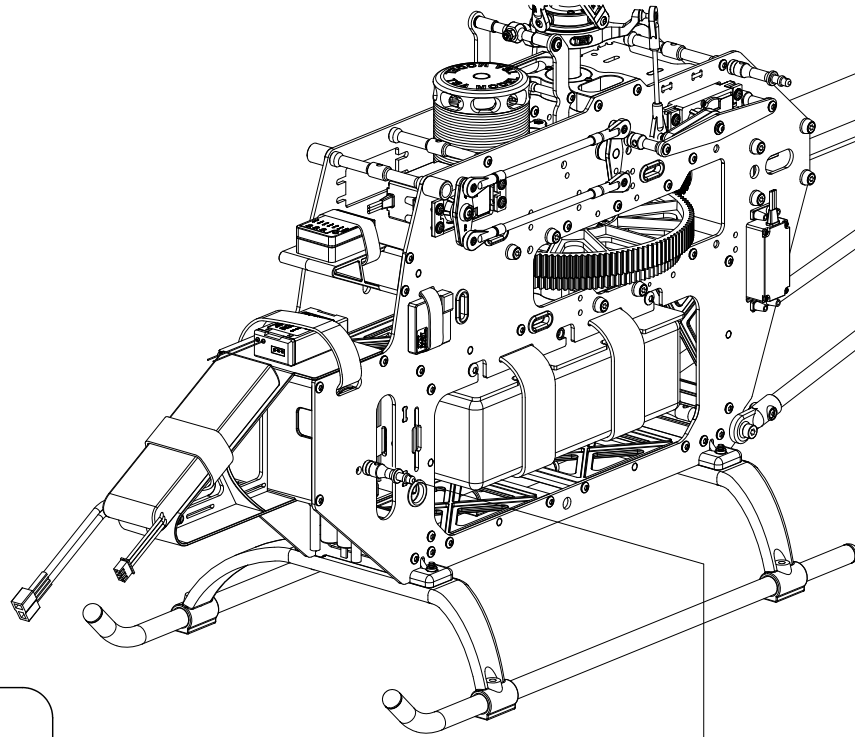
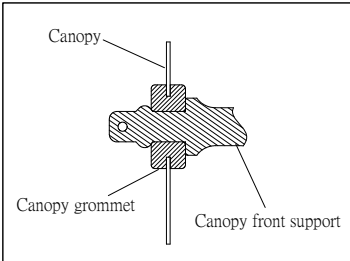
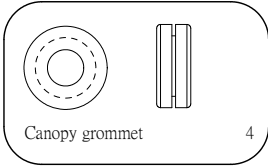



Flybarless gyro setup-3 Axis gyros

Caution

Please refer to the Flybarless gyro instruction manual for setting up the cyclic and tail servo along with the rotor head. This will be specific for each system.



Main blade adjustment

Caution

Precaution during initial setup is for the safety of yourself and others, so please make sure the heli is flying at least 10m away from any person.

1. Increase pitch slowly until the helicopter comes to a stable hover. Note any separation in the rotor blades.
2. Observe the blade tracking:
If main blades are in the same track, then no adjustment required. However, if one blade appears higher than the another blade, then adjustments must be made.
3. Adjust pitch rod tracking:
A. Main blade is higher → reduce length of linkage rod
B. Main blade is lower → add the length of linkage rod

Caution

Improper tracking will result in vibration, Adjust track until both blades are tracking in the same plane.

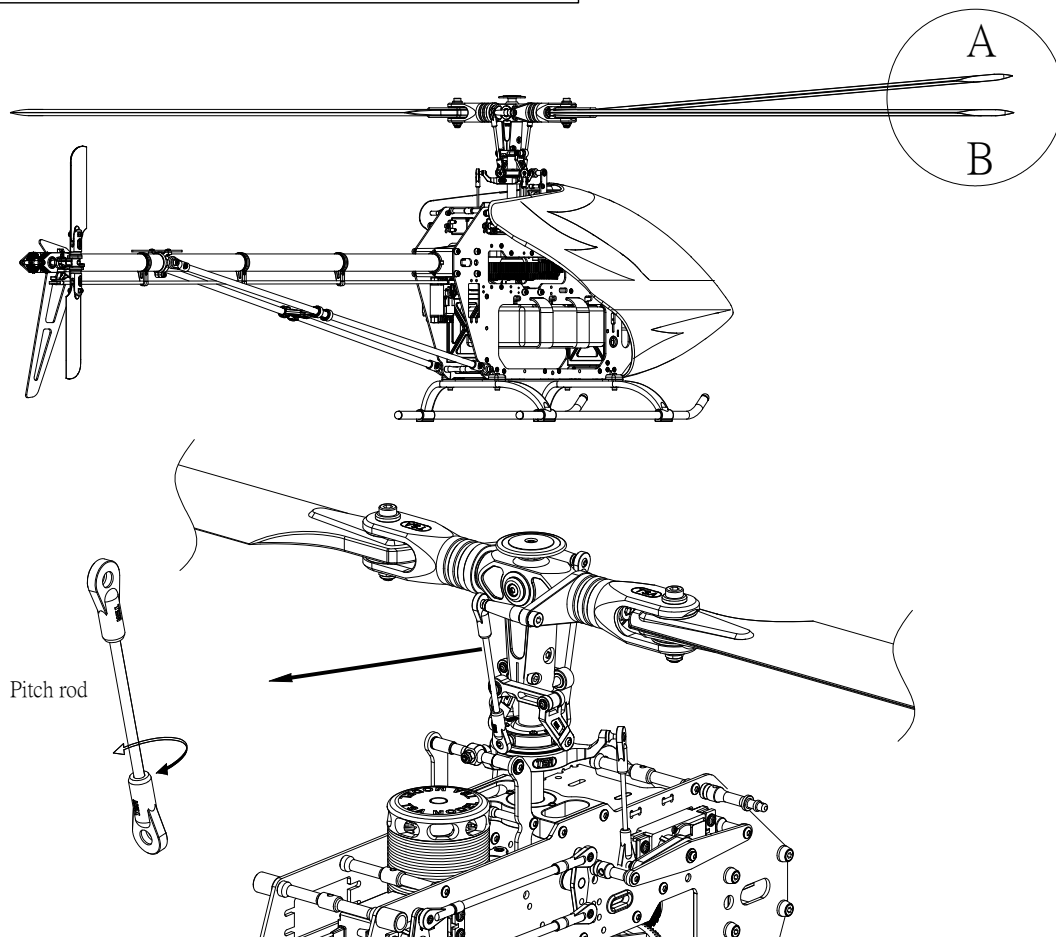





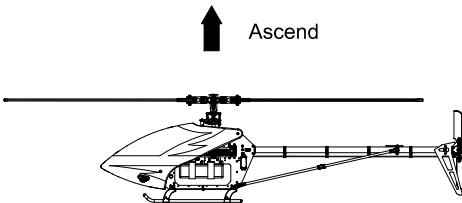
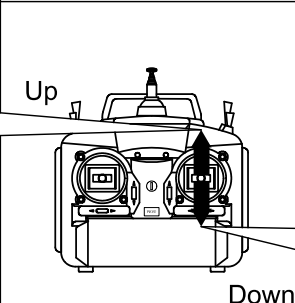
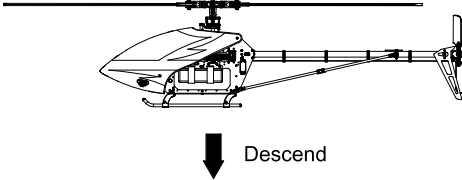
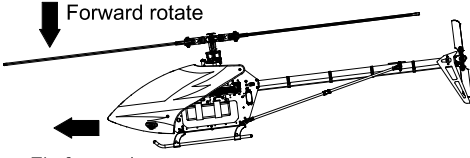
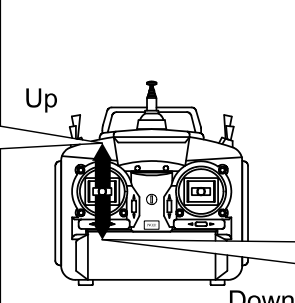
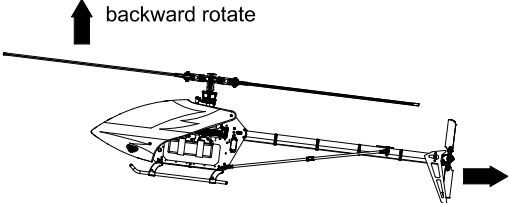
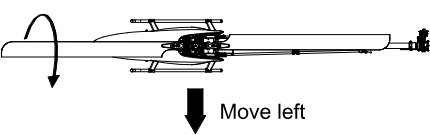
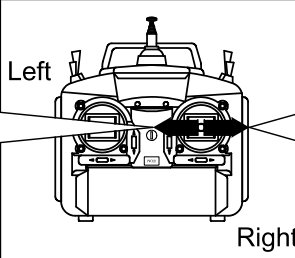
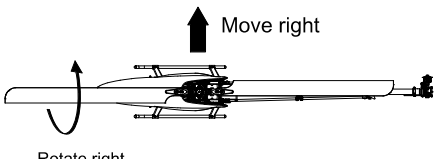

Caution

Beginners should know the designated operating mode of (TSA)700E-3D before operating to avoid accidents

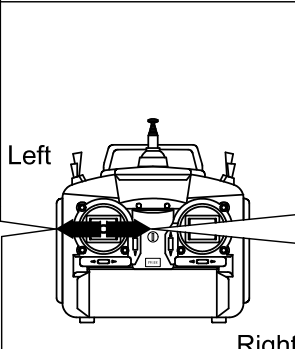
(Mode 1)





 <p>Ascend</p> <p>Pushing the pitch control upward will cause the unit to ascend.</p>	<p>Throttle / Pitch</p>  <p>Up</p> <p>Down</p>	 <p>Descend</p> <p>Push the pitch control down, then the unit will descend.</p>
 <p>Forward rotate</p> <p>Fly forward</p> <p>Pushing the elevator control up, then the unit will go forward.</p>	<p>Elevator</p>  <p>Up</p> <p>Down</p>	 <p>backward rotate</p> <p>Fly backward</p> <p>Push the elevator control down, then the unit will go backward.</p>
 <p>Rotate left</p> <p>Move left</p> <p>Push the aileron control left, the unit will move to the left.</p>	<p>Aileron</p>  <p>Left</p> <p>Right</p>	 <p>Move right</p> <p>Rotate right</p> <p>Push the aileron control right, then the unit will move to the right.</p>
 <p>Turn left</p> <p>Push the rudder control to the left, the body and nose of unit will rotate to the left.</p>	<p>Rudder</p>  <p>Left</p> <p>Right</p>	 <p>Turn right</p> <p>Push the rudder control to the right, the body and nose of unit will rotate to the right.</p>

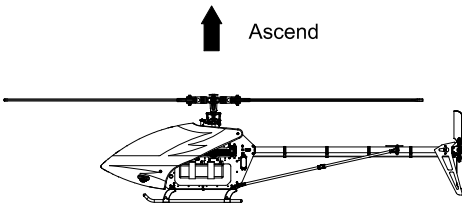
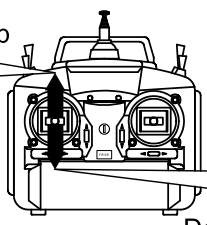
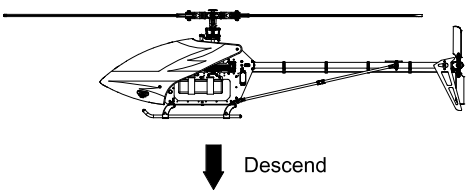
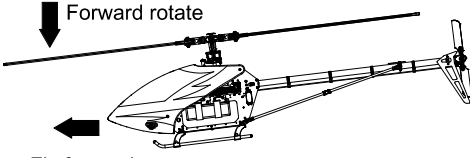
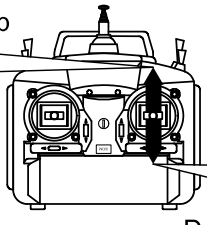
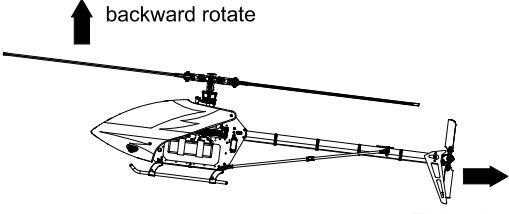
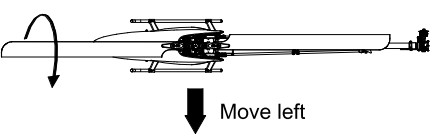
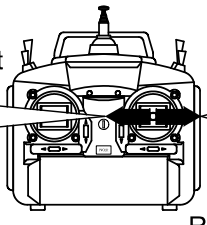
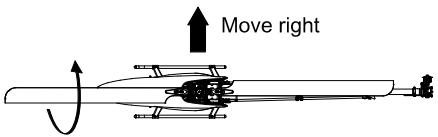

Caution

Beginners should know the designated operating mode of (TSA)700E-3D before operating to avoid accidents

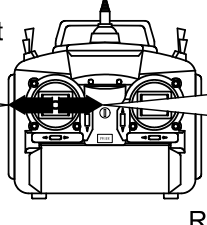
(Mode 2)

 <p>Ascend</p> <p>Pushing the pitch control upward will cause the unit to ascend.</p>	<p>Throttle / Pitch</p>  <p>Up</p> <p>Down</p>	 <p>Descend</p> <p>Push the pitch control down, then the unit will descend.</p>
 <p>Forward rotate</p> <p>Fly forward</p> <p>Pushing the elevator control up, then the unit will go forward.</p>	<p>Elevator</p>  <p>Up</p> <p>Down</p>	 <p>backward rotate</p> <p>Fly backward</p> <p>Push the elevator control down, then the unit will go backward.</p>
 <p>Rotate left</p> <p>Move left</p> <p>Push the aileron control left, the unit will move to the left.</p>	<p>Aileron</p>  <p>Left</p> <p>Right</p>	 <p>Move right</p> <p>Rotate right</p> <p>Push the aileron control right, then the unit will move to the right.</p>
 <p>Turn left</p> <p>Push the rudder control to the left , the body and nose of unit will rotate to the left.</p>	<p>Rudder</p>  <p>Left</p> <p>Right</p>	 <p>Turn right</p> <p>Push the rudder control to the right, the body and nose of unit will rotate to the right .</p>

The helicopter's main and tail rotors spin at very high speed. Make sure to follow these instructions to ensure a safe and enjoyable flight.

Transporting the unit

When transporting the unit to an airfield, secure it to prevent the unit from tipping over. Avoid causing damage to the components which may adversely affect flight performance and safety.

The airfield

Do not fly

1. Near people ,
2. Near buildings ,
3. Near roads, railway tracks, or power lines .

Check the unit before flight

Check that all of the screws are securely fastened. New unit tends to have loose screws. Make sure to check them all before each flight. Check that the transmitter and receiver batteries are fully charged.

The distance of flight

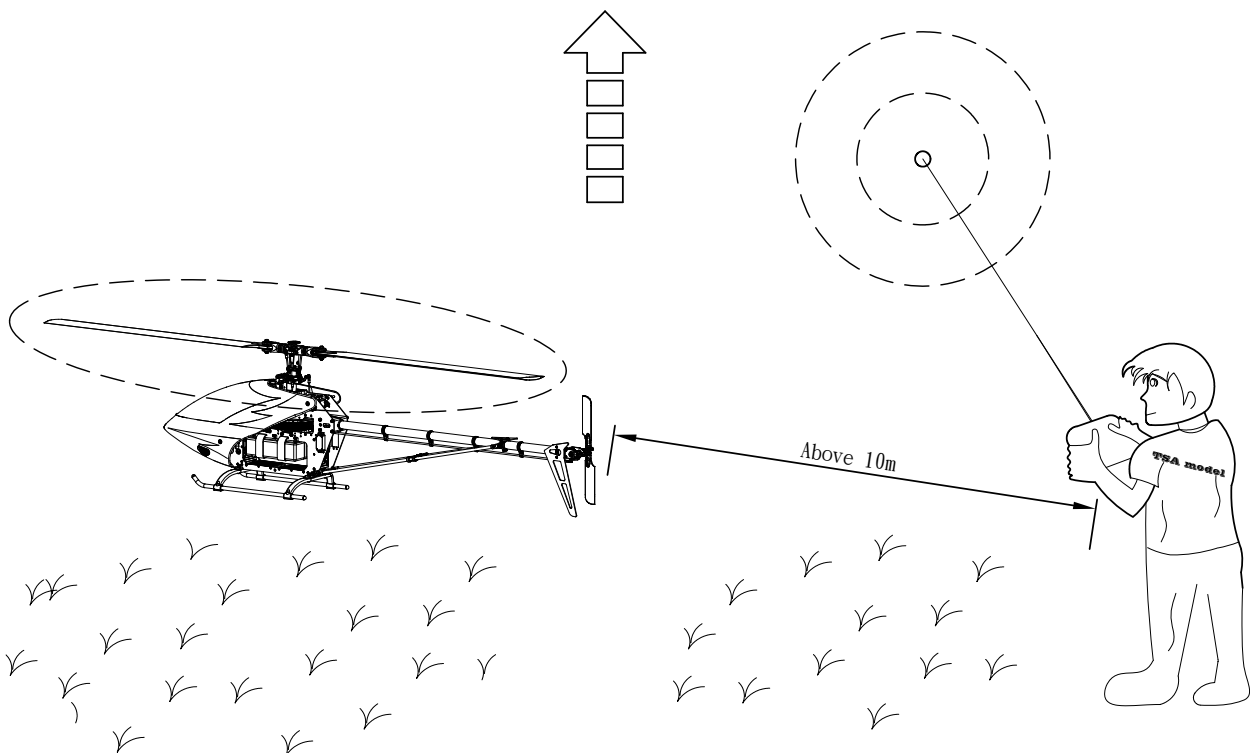
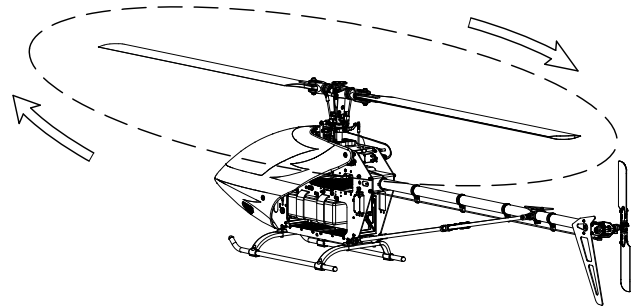

Spare parts

❖ Order Number: TPA00129XX (Left)

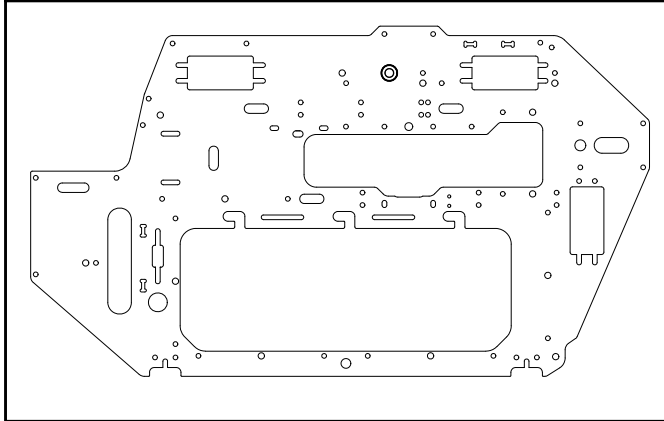

❖ Order Number: TPA00130XX (Right)

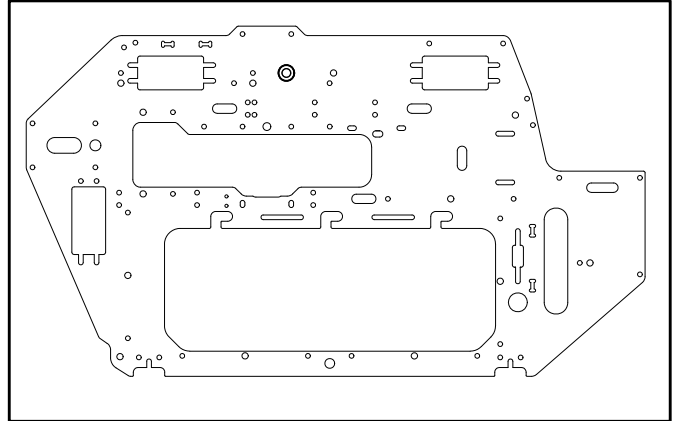

Order Number: TPA06101XX

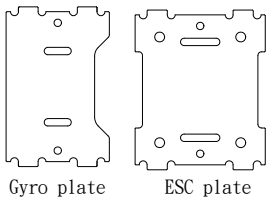

Gyro plate ESC plate

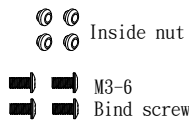

Order Number: TPA00302XX

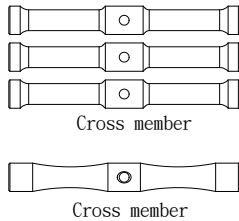

Cross member

Cross member

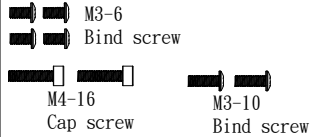

Order Number: TPA05804XX

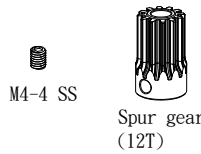

M4-4 SS

Spur gear (12T)

Order Number: TPA0145000

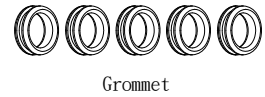

Grommet

Order Number: TPA05806XX

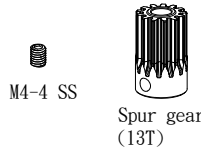

M4-4 SS

Spur gear (13T)

Order Number: TPA00400XX

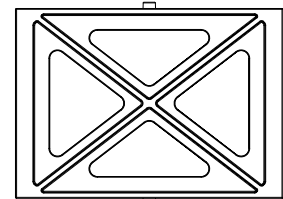

Rigidity brace * 2 pcs

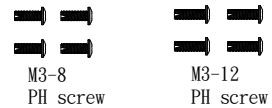

Order Number: TPA01301XX

Order Number: TPA01001XX

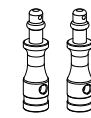

Canopy front support



Order Number: TPA01201XX

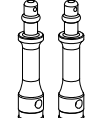

Canopy rear support

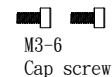

Order Number: TPA01100XX

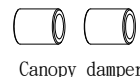

Canopy damper

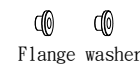

Flange washer

Order Number: TPA00500XX

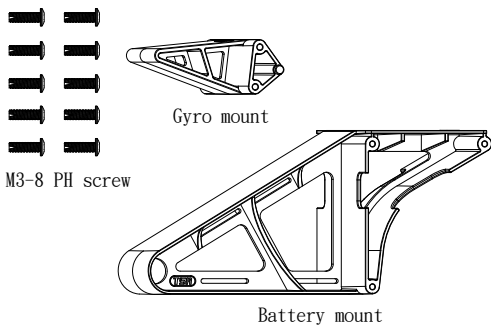

Gyro mount

M3-8 PH screw

Battery mount

❖ Order Number: TPA005901XX

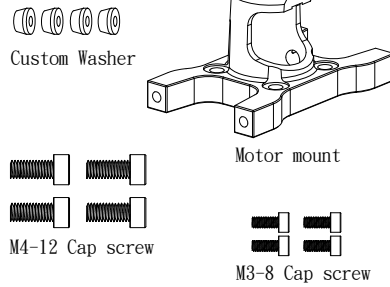

Custom Washer

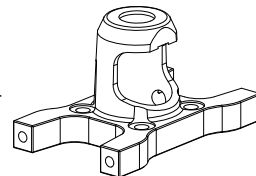

Motor mount

M4-12 Cap screw

M3-8 Cap screw

❖ Order Number: TPA00902XX

❖ Order Number: TPA00701XX

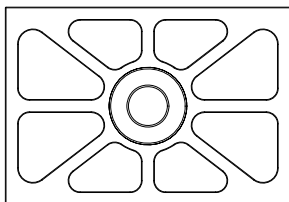

Centre main shaft bearing block

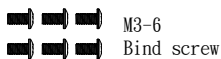

❖ Order Number: TPA00802XX

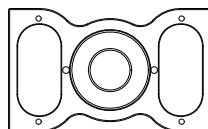

Main shaft bearing block

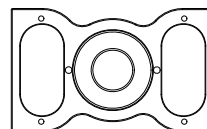
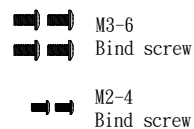

Main shaft bearing block

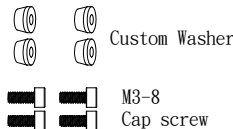

❖ Parts with this symbol have been assembled by the bearing factory.

Order Number: TPA01601XX

Order Number: TPA01400XX

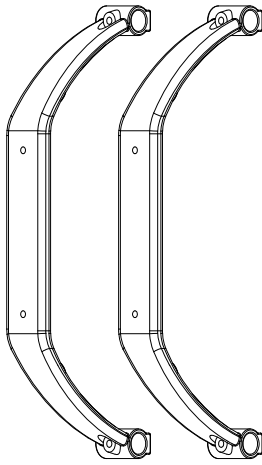

Landing skid



Order Number: TPA01501XX

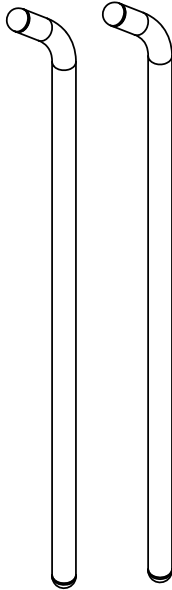

Landing skid tube

Order Number: TPA0043002

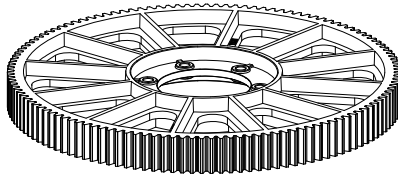

Plastic main gear (126T)

Order Number: TPA03600XX

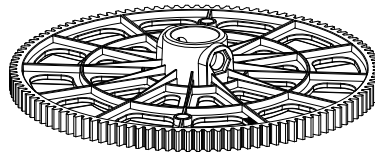

Plastic tail drive gear (113T)

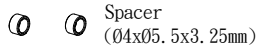

Spacer (Ø4xØ5.5x3.25mm)

Order Number: TPA0121003

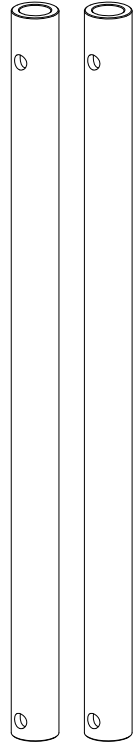

Main shaft

Order Number: TPA01900XX

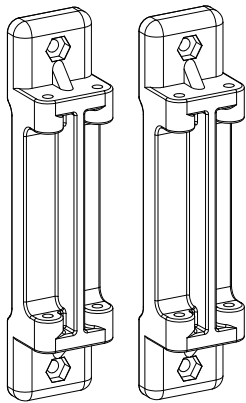

Plastic Skid Mount



M3-12 PH screw



M3-18 Cap screw

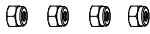

M3 Nylon nut



Ø3xØ8x0.8 Washer

Order Number: TPA03800XX

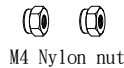

M4 Nylon nut

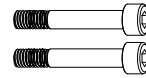

M4-27-6 Cap screw

Order Number: TPA03501XX

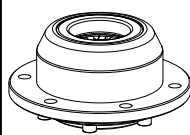

M3-8 Bind screw

Order Number: TPA0122000

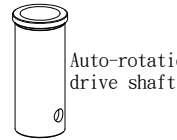

Auto-rotation drive shaft

Order Number: TPA0123000



One way bearing collar

Order Number: TPAB01608X



Ø15xØ23x11 One way bearing

Order Number: TPA02800XX

Order Number: TPA0340000

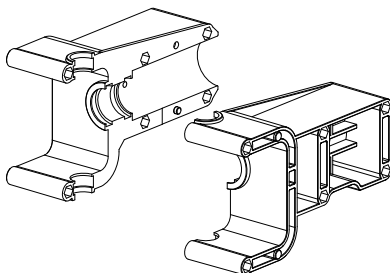

Plastic tail boom clamp

Order Number: TPA02700XX



Ø6xØ13x5 Bearing

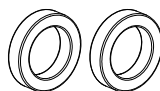

Ø12xØ18x4 Bearing

Order Number: TPA02500XX

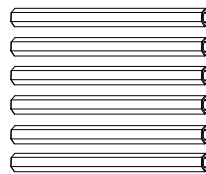

Hex insert



Stator

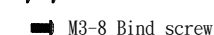
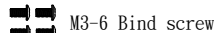

Order Number: TPA02600XX

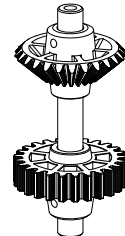

Locating pin (Ø2x12mm)



M3-5 SS

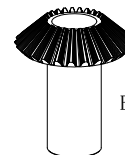

Bevel gear

✳ Order Number: TPA04611XX

Spacer (03x05x3.37mm)

M3-18 SS

M3 Nylon nut

Order Number: TPA04002XX

ARE pivot arm

Spacer (03x04.2x0.5mm)

M3-8 Bind screw

M4-4 SS

Order Number: TPA04101XX

Elevator shaft

M3-6 Bind screw

Order Number: TPA04201XX

Elevator lever

M4-4 SS

5.7mm Ball

M2-7 Cap screw

Order Number: TPA04302XX

Cross member

M3-6 Bind screw

✳ Order Number: TPA04410XX

ARE supports

✳ Order Number: TPA04502XX

ARE Pivot block

Spacer (03x05x3.37mm)

M3-18 SS

M3 Nylon nut

Order Number: TPA0210001

Spacer (05x07x16.55mm)

M3-8 Bind screw

✳ Order Number: TPA20100XX

Order Number: TPA06001XX

M4-8 Bind screw

M3-8 TM screw

Mounting bracket

Battery mount

Order Number: TPA20000XX

Coupling

Pivot ball

12mm Ball

M2-4 Bind screw

Order Number: TPA20201XX

11mm Ball

12mm Ball

13mm Ball

✳ Order Number: TPA20401XX

✳ Order Number: TPA20301XX

Washout control arm

Spacer (02*03.2*0.9mm)

M2-6 Bind screw

Order Number: TPA0306000

Mixing arm

Order Number: TPAB00100X

02x05x2.3 Bearing

Order Number: TPA04700XX

5.7mm Ball

M2 Nut

M2-8 Cap screw

Order Number: TPA20901XX

Order Number: TPA20801XX

Metal Head block

M4-5 Bind screw

M3-15 Cap screw

Spacer (Ø3*Ø4.5*6.2mm)

M3-20 Bind screw

Order Number: TPA20601XX

Teeter hub

Acetyl bearing

Custom washer

M3-6 Bind screw

Order Number: TPA0302001

Feathering shaft guide

Order Number: TPA0141001

Damper50* (black)

Order Number: TPA20700XX

Head button

M3-12 Bind screw

Order Number: TPA20501XX

Spindle (Ø10*111.2mm)

M6-12 Cap screw

Ø6xØ13x2 Washer

Order Number: TPA0201001

Damper shim (Ø10*Ø15.5*1mm)

✳ Order Number: TPA21203XX

Blade grip

Spacer (Ø5*Ø22*1.5mm)

Order Number: TPA21101XX

Pitch arm

11mm Ball

M5 Nylon nut

M5-32-8 Cap screw

M4-10 Cap screw

Order Number: TPA21002XX

M5 Nylon nut

M5-32-6 Cap screw

Order Number: TPA21301XX

Rod (M2.75*65mm)

Ball link (23mm)

✳ Order Number: TPA42001XX

M3 Nylon nut

M3-17-5 Cap screw

M4-4 SS

✳ Order Number: TPA41901XX

Tail blade grip

Order Number: TPA41801XX

M3 Nylon nut

M3-17-5 Cap screw

Order Number: TPA41700XX

Tail spindle

M4-4 SS

M4 Nylon nut

✱ Order Number: TPA42101XX

- M3-6 Bind screw
- M3-18 Bind screw
- spacer (Ø3*Ø4.5*3mm)
- M3-12 Cap screw
- M3-5 Bind screw

✱ Order Number: TPA41301XX

Metal tail gearbox clamp

- M3-5 Bind screw
- M3-6 Bind screw
- M3-12 Cap screw

Order Number: TPA40900XX

Metal tail output shaft

- Locating pin (Ø2x12mm)
- M3-5 SS

✱ Order Number: TPA41200XX

Tail case left Tail case right

- Tail spacer standoff (29.5mm)
- M3-6 Bind screw

Order Number: TPA02300XX

Bevel gear Bevel gear

Order Number: TPA40800XX

Locking collar

- M3-3 SS

Order Number: TPA41100XX

Pivot mount

- spacer (Ø3*Ø4.5*3mm)
- M3-6 Bind screw
- M3-18 Bind screw

Order Number: TPA41000XX

Tail bell crank

- 5.7mm Ball
- M2-8 Cap screw
- M2 Nut

Order Number: TPA41601XX

Metal tail boom clamp

- M3-5 Bind screw
- M4-12 Cap screw
- M3-10 Cap screw

Order Number: TPA41402XX

Tail pitch links

- Spacer (Ø2*Ø3.2*0.9mm)
- M2-6 Bind screw

Order Number: TPA40001XX

Metal tail boom clamp

- M3-5 Bind screw
- M4-12 Cap screw
- M3-10 Cap screw

Order Number: TPA42301XX

Vertical fin

Horizontal fin

Order Number: TPA04801XX

Servo support

- M3-6 Bind screw
- M3-6 Cap screw

Order Number: TPA04901XX

Servo support plate

Servo support guide

- M2.6-12 Bind screw (Futaba)
- M3-12 Bind Screw (JR)

Order Number: TPA06602XX

Carbon fiber tube (79.5mm)

Carbon fiber shaft

Order Number: TPA05203XX

Rod (M2.2*50mm)

Rod (M2.8*65mm)

Rod (M2.2*100mm)

Order Number: TPA05500XX

Servo horn (JR)

Lever (JR)

5.7mm Ball

M2 Nut

M2-8 Cap screw

Order Number: TPA05300XX

Ball link

Ball link-long

Order Number: TPA05400XX

Lever (JR)

13mm Ball

Order Number: TPA05701XX

Servo mounting plate

Servo mounting plate

Servo stand

M2.6-18 PH screw

M2.6-26 PH screw

Order Number: TPA05501XX

Servo horn (Futaba)

Lever (Futaba)

5.7mm Ball

M2 Nut

M2-8 Cap screw

Order Number: TPA06500XX

Wire clamp

Wire clamp

Wire clamp

Order Number: TPA05401XX

Lever (Futaba)

13mm Ball

Order Number: TPA40201XX

Boom support brace (Ø8)

Boom clamp (Ø8)

M2 Nut

M2-10 Cap screw

M3 Nylon nut

M3-10 Cap screw

Order Number: TPA40100XX

Push rod guide

M2 Nut

M2-8 Cap screw

Order Number: TPA0333000

Servo plate

Order Number: TPA0172000

T/T drive end

Order Number: TPA40301XX

Boom support end (Ø8)

M2.6-12-3 Bind screw

M2.6 Nut

Order Number: TPA40600XX

Bearing carrier

Order Number: TPA40701XX

Topque tube (781.5mm)

Order Number: TPA40502XX

Ball link-long (23mm)

Rudder rod (M2.2*773mm)

Order Number: TPA40410XX

Tail boom support (Ø8*597mm)

Order Number: TPA0084002

tail boom (788mm)

Order Number: TPA90000XX

Silicone grease

Retainer

5 minute epoxy

Order Number: TPA60301XX

Canopy

Canopy grommet

Specifications

- ★ Full length of fuselage ----- 1368mm
- ★ Full width of fuselage ----- 215mm
- ★ Height ----- 410mm
- ★ Flying weight (12s5000mAh approx) ----- 5390g
- ★ Main rotor diameter ----- 1580mm
- ★ Tail rotor diameter ----- 262mm
- ★ Engine class ----- 4,500~11,000W/500~550KV
- ★ Gear ratio ----- 9.0/9.69/10.5/11.45:1:4.52
- ★ Main gear ratio ----- 11T:12T/13T/14T:126T
- ★ Tail gear ratio ----- 113T:25T
- ★ Main blade (not included) ----- 680~710mm
- ★ Tail blade (not included) ----- 90~110mm
- ★ Power battery ----- 6S Li-Po 4000~5000mAh 2pcs



***** **INFUSION 700E**
Platinum

Customer Support: sales@tsamodel.com



Safety Precautions

Helicopter spinning blades are potential dangerous. Please ensure to maintain a minimum distance of 10m from the aircraft at all times. It is the responsibility of the builder to ensure the aircraft is airworthy and safe to operate in the designated area. On going maintenance is required by the operator to ensure continuous safe use and all damaged parts should be replaced immediately.

Small components are included in the kit, please ensure the kit parts are kept out of children's reach, as they are small enough to swallow.

Use only TSA Model genuine parts, failure to do so could result in damage to both the aircraft and personal in the area. TSA Model takes no responsibility for the operational use of the aircraft.



Caution

Reproduction of the manual and any TSA components are strictly prohibited.

The contents of this manual are subject to change without prior notice.

Every effort has been made to ensure that this manual is complete and correct.