

GP750 Head Lock Gyro Instruction Manual

Features

- Utilizes Silicon Micro Machines (SMM) sensor with excellent stability to dramatically reduce in-flight tail drifts.
- Utilizes AHTCS (Active Helicopter Tail Control System) to compensate any drift caused by wind direction and force, as well as unintended yaw induced by helicopter itself during flight maneuvers.
- Tailor made specifically for use with high speed digital rudder servos. This gyro features high sensitivity and minimal reaction time, fully utilizing the potential of modern high speed digital rudder servos.
- Suitable for all sizes of helicopters, from micro indoor to large 90 size glow helicopters.
- Metallic dampening plate built into bottom gyro casing, dramatically increasing anti-vibration and anti-interference abilities.
- Features 1520 μ s pulse wide and 760 μ s narrow pulse wide frame rate.
- Digital/Analog servo switchable.
- Reverse switch.
- Rudder servo travel limit adjustment (ATV).
- Mode switch for large/mini helicopter.
- Delay adjustment.
- Gyro locking mode and gain can be adjusted remotely from the transmitter.

Program setting table

Setting type	1520/760 μ s	DS/AS	NOR/REV	LIMIT	Helicopter mode / DELAY
"STATUS"green	▲Standard 1520 μ s Servo	▲Digital servo	▲Normal rotation	Left(Right)Travel limit	Medium/ large heli. suitable for T-REX500/600/700
"STATUS"red	Narrow band 760 μ s Servo	Analog Servo	Reverse rotation	Right(Left)Travel limit	Mini/ Micro heli. suitable for T-REX250/450
Setting instruction	See no. 2 in setting instructions	See no. 3 in setting instructions	See no. 5 in setting instructions	See no. 6 in setting instructions	See no. 8 in setting instructions

NOTE : 1. "▲"Default setting . 2. Wrong heli mode will affect the performance of gyro. Do not fly before the complete setting.

Specifications

Gyro :

- Operating Voltage : DC 4.5~7V
- Current Consumption : <80mA @ 4.8V
- Angular Detection Speed : \pm 500 degrees/sec
- Operating Temperature : 0°C~65°C
- Operating Humidity : 0%~95%
- Size : 26x25x11mm
- Weight : 14g
- RoHS compliant

DS620 Digital Servo :

- Speed : 0.09sec /60 degrees(4.8V)
0.07sec /60 degrees(6.0V)
- Torque : 8kg.cm (4.8V)
10kg.cm (6.0V)
- Dimension : 40.3 x 20.1 x 36mm
- Weight: 52.2g(Servo horn not included)

Illustration

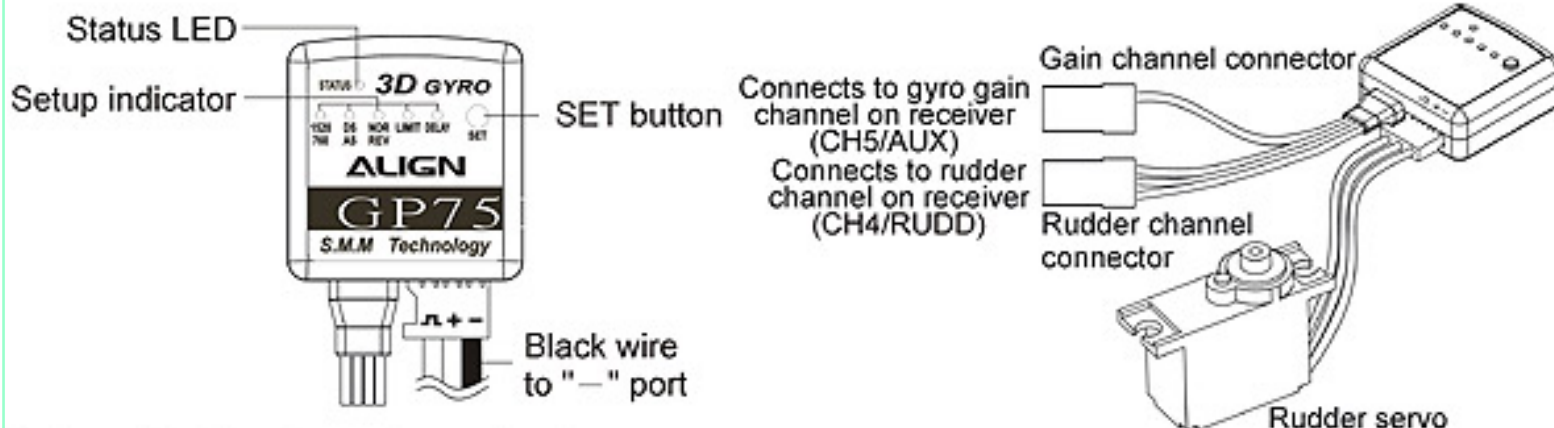

Gain and Rudder channel mapping diagram

Transmitter type	Rudder channel on Receiver	Gain channel on Receiver
JR PPM/SPCM	"RUDD"	"AUX 2" or "AUX 3"
Hitec、Futaba PPM/PCM	"CH4"(RUD)	"CH5"
JR ZPCM	"RUDD"	"AUX 2"

Gyro Installation

1. Utilizing the included double sided foam tape as shown in diagram below, mount the gyro on a solid platform or designated gyro mounting location on the helicopter. Ensure gyro mounting area have proper ventilation and away from heat sources.
2. To avoid drift induced by erroneous yaw detection, the bottom surface of gyro must be perpendicular (90 degrees) relative to the main shaft.
3. For installation on electric powered helicopters, the gyro should be installed as far away from the electronic speed controller (ESC) as possible to avoid interference (minimum 5cm).

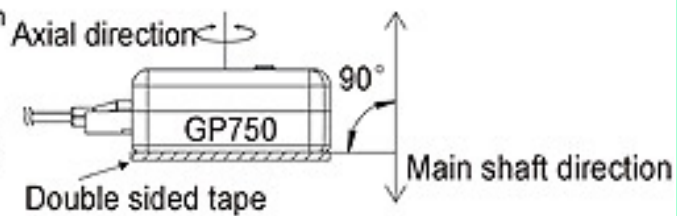

[Next](#) [Back](#)